

AVT-55689
 50 – 6000 MHz
 InGaP HBT Gain Block



Data Sheet

Description

Avago Technologies' AVT-55689 is an economical, easy-to-use, general purpose InGaP HBT MMIC gain block amplifier utilizing Darlington pair configuration housed in a 3-lead (SOT 89) surface mount plastic package.

The Darlington feedback structure provides inherent broad bandwidth performance, resulting in useful operating frequency up to 6 GHz. This is an ideal device for small-signal gain cascades or IF amplification.

AVT-55689 is fabricated using advanced InGaP HBT (hetero-junction Bipolar Transistor) technology that offering state-of-the-art reliability, temperature stability and performance consistency.

Component Image

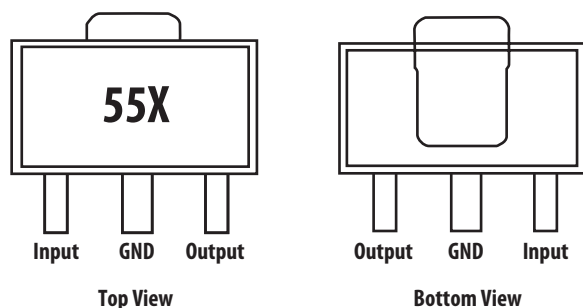

Notes:

Package marking provides orientation and identification
 "55" = Device Code
 "X" = Month of manufacture



Attention: Observe precautions for handling electrostatic sensitive devices.
 ESD Machine Model = 140 V
 ESD Human Body Model = 1600 V
 Refer to Avago Application Note A004R:
 Electrostatic Discharge, Damage and Control.

Features

- Small signal gain amplifier
- Operating frequency 50 MHz to 6 GHz
- Unconditionally stable
- 50 Ohm input & output
- Industry standard SOT-89
- Lead-free, RoHS compliant, Green

Specifications

2 GHz, 5 V Vcc, 75 mA (typ.)

- 17.2 dB Gain
- 19.5 dBm P1dB
- 32.5 dBm OIP3
- 4.3 dB NF
- 19 dB IRL and 10.7 dB ORL

Applications

- Wireless Data / WLAN
- WiMAX / WiBro
- CATV & Cable modem
- ISM

Typical Biasing Configuration

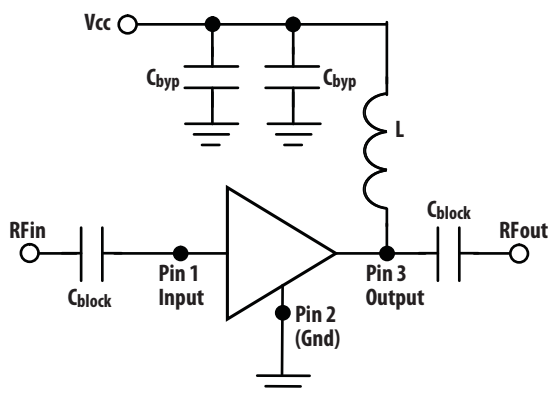

Absolute Maximum Rating ⁽¹⁾ $T_A = 25^\circ\text{C}$

Symbol	Parameter	Units	Absolute Max.
$V_{d, \text{MAX}}$	Device Voltage	V	5.5
$P_{\text{IN, MAX}}$	CW RF Input Power	dBm	18
P_{DISS}	Total Power Dissipation ⁽²⁾	mW	550
T_{OPT}	Operating Temperature	$^\circ\text{C}$	-40 to 85
$T_{\text{J, MAX}}$	Junction Temperature	$^\circ\text{C}$	150
T_{STG}	Storage Temperature	$^\circ\text{C}$	-65 to 150

Thermal Resistance

Thermal Resistance ⁽³⁾ $\theta_{\text{JB}} = 111^\circ\text{C/W}$
($I_d = 75\text{ mA}$, $T_b = 85^\circ\text{C}$)

Notes:

1. Operation of this device in excess of any of these limits may cause permanent damage.
2. Ground lead temperature is 25°C . Derate $8.9\text{ mW}/^\circ\text{C}$ for $T_c > 108^\circ\text{C}$.
3. Thermal resistance measured using Infrared measurement technique.

Electrical Specification ⁽¹⁾

$T_A = 25^\circ\text{C}$, $Z_o = 50\ \Omega$, $V_{\text{CC}} = 5\text{ V}$, $P_{\text{in}} = -15\text{ dBm}$ (unless specified otherwise)

Symbol	Parameter and Test Condition	Frequency	Units	Min.	Typ.	Max.
I_d	Device Current		mA	66	75	86
G_p	Power Gain	900 MHz 2000 MHz	dB	15.5	18.8 17.2	18.5
$f_{3\text{dB}}$	3 dB Bandwidth		GHz		2.5	
OIP3 ⁽²⁾	Output 3 rd Intercept Point	900 MHz 2000 MHz	dBm	30	35 32.5	
S11	Input Return Loss, $50\ \Omega$ source	900 MHz 2000 MHz	dB		-27 -19	
S22	Output Return Loss, $50\ \Omega$ load	900 MHz 2000 MHz	dB		-14 -10.7	
S12	Reverse Isolation	900 MHz 2000 MHz	dB		-22.6 -22.7	
P1dB	Output Power at 1 dB Gain Compression	900 MHz 2000 MHz	dBm		20.6 19.5	
NF	Noise Figure	900 MHz 2000 MHz	dB		4.1 4.3	

Note :

1. Measurements obtained on CPWG line with reference plane at the ends of DUT leads (as shown in Figure 1).
2. OIP3 test condition: $F_{\text{RF1}} - F_{\text{RF2}} = 10\text{ MHz}$ with input power of -15 dBm per tone measured at worse side band.

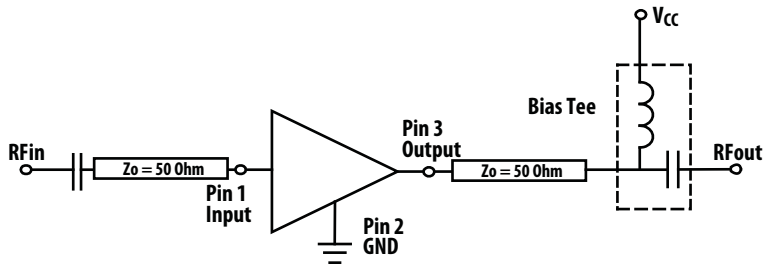

Figure 1. Block diagram of board used for I_d , Gain, OIP3, S11, S22, S12, OP1dB and NF measurements. Circuit losses have been de-embedded from actual measurements.

Product Consistency Distribution Charts at 2 GHz, $V_{CC} = 5\text{ V}$

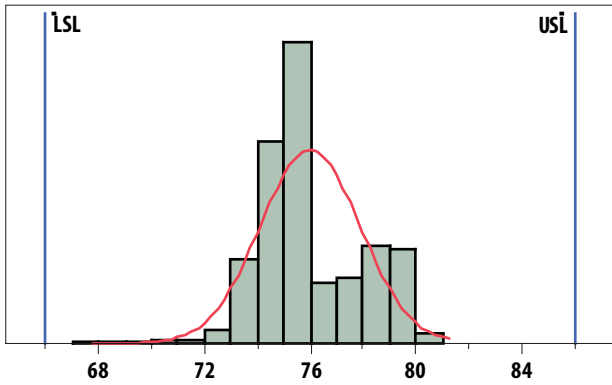

Figure 2. I_d (mA) distribution. LSL = 66, Nominal = 76, USL = 86.

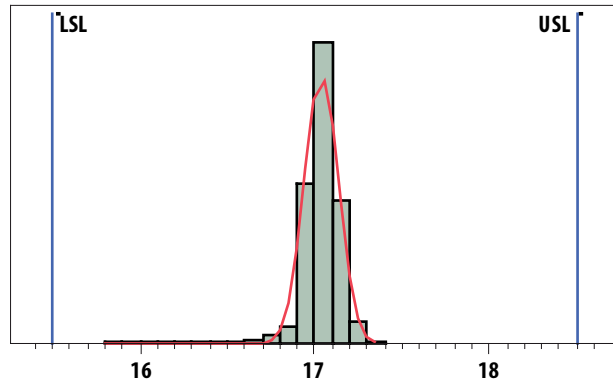

Figure 3. Gain (dB) distribution. LSL = 15.5, Nominal = 17, USL = 18.5.

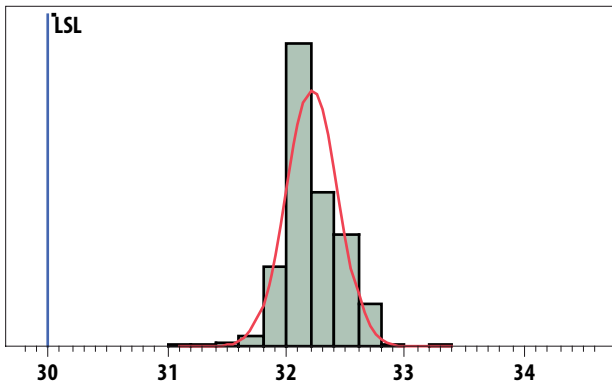

Figure 4. OIP3 (dBm) distribution. LSL = 30, Nominal = 32.2.

Notes:

1. Statistical distribution determined from a sample size of 9175 samples taken from 6 different wafers, measured on a production test board.
2. Future wafers allocated to this product may have typical values anywhere between the minimum and maximum specification limits.

AVT-55689 Typical Performance Curves

$T_A = 25^\circ\text{C}$, $Z_o = 50\ \Omega$, $V_{CC} = 5.0\text{V}$, $P_{in} = -15\text{ dBm}$ (unless specified otherwise)

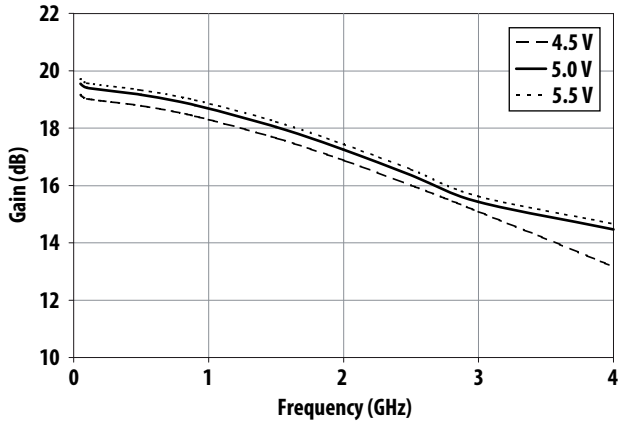

Figure 5. Gain vs. Frequency and Voltage

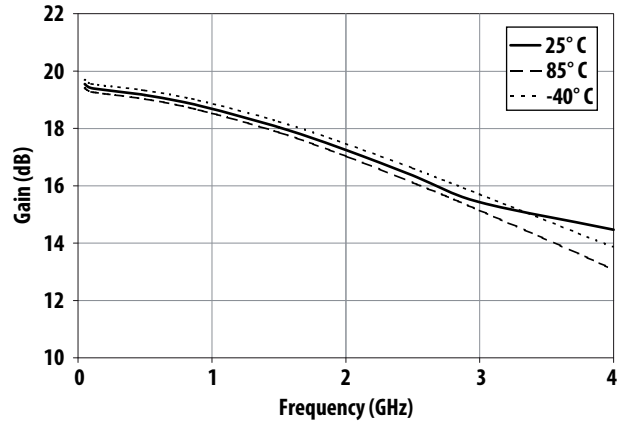

Figure 6. Gain vs. Frequency and Temperature

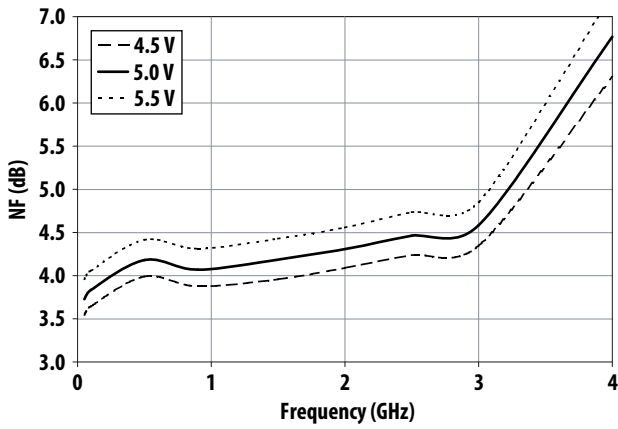

Figure 7. Noise Figure vs. Frequency and Voltage

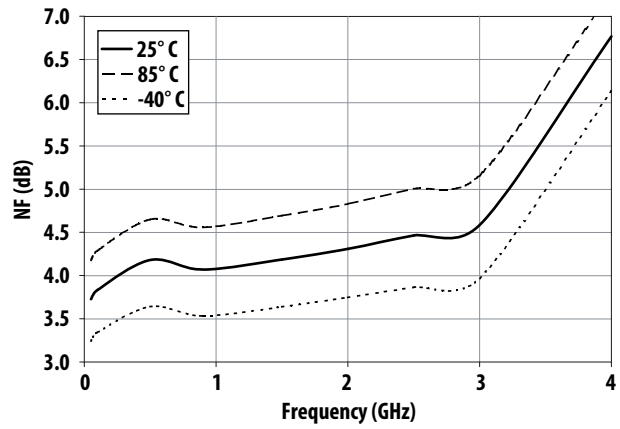

Figure 8. Noise Figure vs. Frequency and Temperature

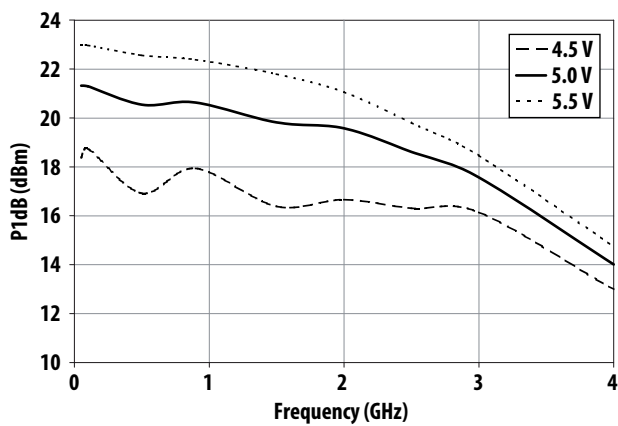

Figure 9. P1dB vs. Frequency and Voltage

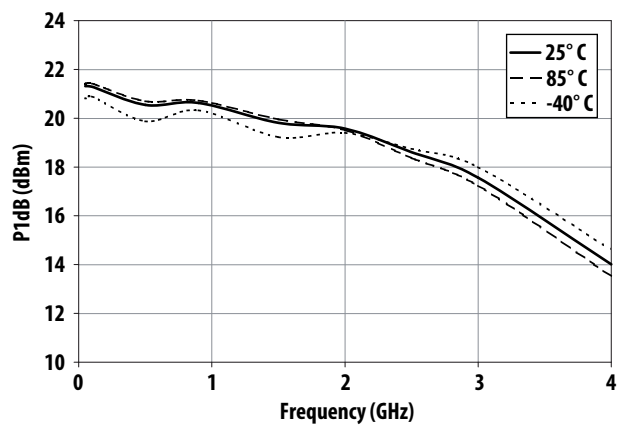

Figure 10. P1dB vs. Frequency and Temperature

AVT-55689 Typical Performance Curves

$T_A = 25^\circ\text{C}$, $Z_o = 50\ \Omega$, $V_{CC} = 5.0\ \text{V}$, $P_{in} = -15\ \text{dBm}$ (unless specified otherwise), continued

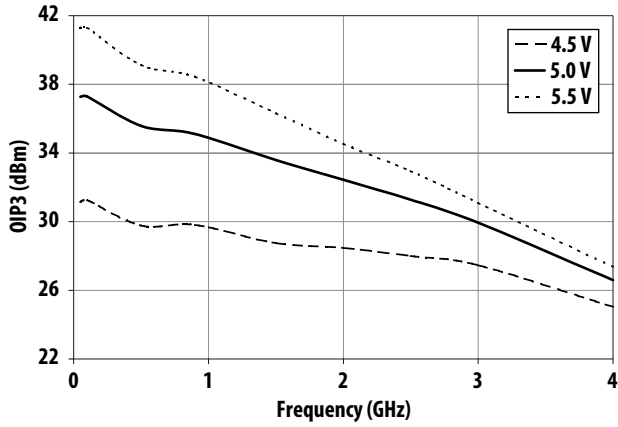

Figure 11. OIP3 vs. Frequency and Voltage

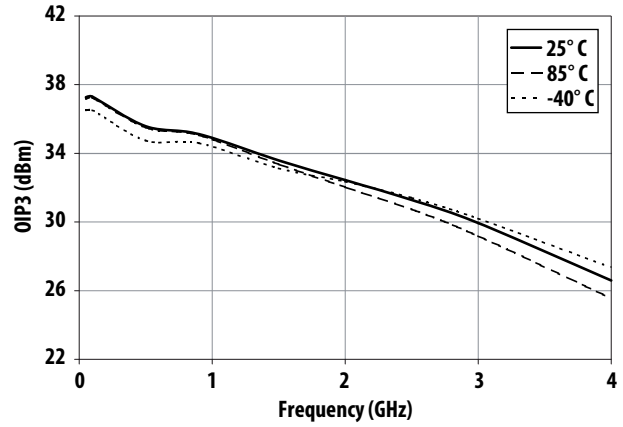

Figure 12. OIP3 vs. Frequency and Temperature

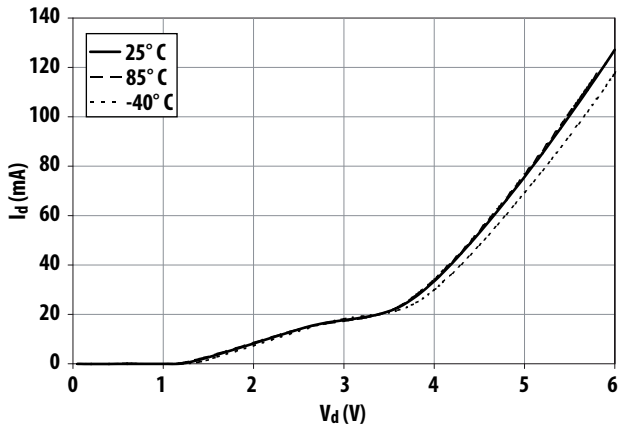

Figure 13. I_d vs V_d and Temperature

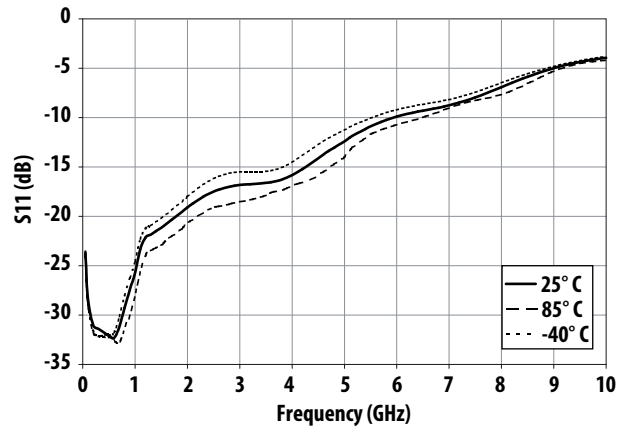

Figure 14. S11 vs Frequency and Temperature

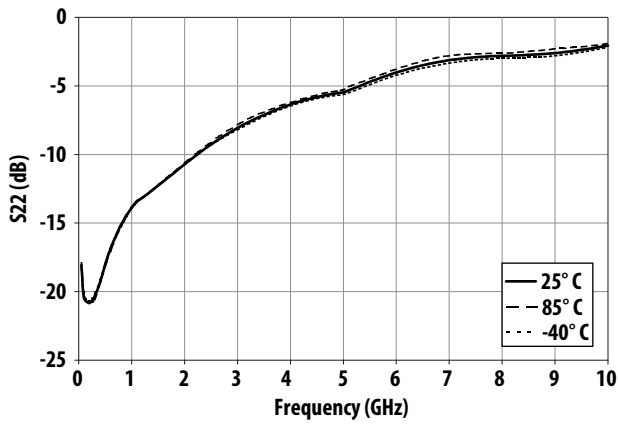

Figure 15. S22 vs Frequency and Temperature

AVT-55689 Typical Scattering Parameters $T_A = 25^\circ C$, $Z_0 = 50 \Omega$, $V_{CC} = 4.5 V$, (unless specified otherwise)

Freq (GHz)	S11		S21		S12		S22		K	
	mag	angle	dB	mag	angle	mag	angle	mag		angle
0.05	0.06	-86.4	19.16	9.08	172.5	0.08	4.2	0.15	-38.6	1.0
0.10	0.03	-96.8	19.02	8.94	171.9	0.08	0.6	0.12	-31.7	1.1
0.50	0.03	26.8	18.78	8.69	151.4	0.08	-9.6	0.15	-61.8	1.1
0.90	0.06	-19.2	18.41	8.33	130.0	0.08	-17.4	0.21	-90.2	1.1
1.50	0.11	-57.6	17.66	7.63	98.8	0.08	-28.1	0.26	-126.7	1.1
2.00	0.13	-85.0	16.87	6.98	73.7	0.08	-36.5	0.30	-159.4	1.1
2.50	0.15	-109.9	16.00	6.31	49.7	0.08	-44.9	0.35	172.1	1.1
3.00	0.16	-134.3	15.09	5.68	26.7	0.08	-53.8	0.40	146.4	1.1
3.50	0.16	-163.0	14.15	5.10	4.2	0.08	-63.5	0.45	122.8	1.1
4.00	0.17	164.0	13.17	4.55	-17.6	0.08	-74.2	0.48	101.2	1.1
4.50	0.20	134.5	12.14	4.05	-38.8	0.09	-85.7	0.51	81.9	1.1
5.00	0.24	113.5	11.12	3.60	-59.0	0.09	-97.5	0.53	65.0	1.1
5.50	0.28	78.8	9.86	3.11	-81.5	0.09	-112.7	0.58	36.5	1.1
6.00	0.31	57.6	8.58	2.68	-101.6	0.09	-126.4	0.63	18.3	1.1
6.50	0.33	38.8	7.32	2.32	-120.6	0.09	-139.8	0.67	3.3	1.2
7.00	0.36	19.7	6.13	2.03	-139.0	0.09	-153.3	0.70	-10.2	1.2
7.50	0.39	0.6	4.99	1.78	-157.0	0.09	-167.1	0.72	-23.1	1.3
8.00	0.44	-16.3	3.81	1.55	-174.4	0.09	179.2	0.72	-35.8	1.3
8.50	0.50	-29.6	2.56	1.34	169.0	0.08	165.9	0.73	-48.6	1.4
9.00	0.56	-39.7	1.20	1.15	153.6	0.08	153.2	0.74	-61.0	1.5
9.50	0.60	-47.9	-0.26	0.97	139.4	0.07	141.4	0.76	-72.5	1.6
10.00	0.63	-55.7	-1.78	0.81	126.2	0.07	130.4	0.79	-82.3	1.7
10.50	0.65	-64.4	-3.33	0.68	113.8	0.06	119.6	0.82	-90.4	1.8
11.00	0.67	-74.7	-4.86	0.57	101.6	0.06	109.0	0.84	-97.4	1.9
11.50	0.69	-86.5	-6.35	0.48	89.3	0.05	97.9	0.86	-104.3	2.1
12.00	0.72	-99.1	-7.78	0.41	76.4	0.05	86.1	0.87	-111.7	2.3
12.50	0.75	-111.1	-9.10	0.35	63.5	0.05	74.0	0.88	-119.8	2.6
13.00	0.78	-121.1	-10.27	0.31	51.0	0.04	62.5	0.88	-128.3	2.8
13.50	0.80	-128.5	-11.29	0.27	39.8	0.04	51.8	0.88	-137.0	2.9
14.00	0.81	-133.8	-12.15	0.25	29.7	0.04	42.4	0.88	-145.5	3.0
14.50	0.82	-137.8	-12.88	0.23	20.6	0.04	34.2	0.89	-153.0	3.1
15.00	0.81	-141.8	-13.51	0.21	12.1	0.04	26.3	0.90	-159.7	3.3
16.00	0.79	-154.3	-14.78	0.18	-5.3	0.04	12.4	0.90	-171.7	4.4
17.00	0.79	-171.8	-15.94	0.16	-21.9	0.04	3.8	0.91	176.5	4.4
18.00	0.81	172.9	-17.08	0.14	-38.4	0.04	-9.0	0.91	164.6	4.4
19.00	0.81	160.9	-17.87	0.13	-53.8	0.04	-21.2	0.91	150.9	4.8
20.00	0.78	147.2	-18.38	0.12	-69.3	0.05	-33.3	0.90	136.8	5.7

Notes:

1. S-parameters are measured on a CPWG line fabricated on 0.025 inch thick Rogers® RO4350 material. The input reference plane is at the end of the input lead. The output reference plane is at the end of the output lead.

AVT-55689 Typical Scattering Parameters $T_A = 25^\circ C$, $Z_0 = 50 \Omega$, $V_{CC} = 5.0 V$, (unless specified otherwise)

Freq (GHz)	S11		S21		S12		S22		K	
	mag	angle	dB	mag	angle	mag	angle	mag		angle
0.05	0.07	-112.9	19.54	9.49	172.4	0.08	3.8	0.13	-46.3	1.0
0.10	0.04	-144.7	19.40	9.34	171.9	0.08	0.3	0.09	-39.1	1.1
0.50	0.02	89.5	19.16	9.08	151.4	0.07	-9.7	0.13	-68.6	1.1
0.90	0.04	-3.2	18.80	8.71	129.8	0.07	-17.5	0.19	-95.1	1.1
1.50	0.09	-53.3	18.04	7.98	98.5	0.07	-28.2	0.24	-130.6	1.1
2.00	0.11	-83.2	17.24	7.28	73.3	0.07	-36.5	0.29	-162.7	1.1
2.50	0.13	-109.5	16.36	6.58	49.1	0.07	-44.8	0.34	169.5	1.1
3.00	0.14	-134.9	15.43	5.91	26.0	0.07	-53.3	0.40	144.4	1.1
3.50	0.15	-164.8	14.47	5.29	3.5	0.08	-62.8	0.44	121.3	1.1
4.00	0.16	161.5	13.47	4.72	-18.5	0.08	-73.3	0.48	99.9	1.1
4.50	0.20	132.2	12.43	4.18	-39.7	0.08	-84.5	0.51	80.9	1.1
5.00	0.24	111.4	11.39	3.71	-60.0	0.09	-96.1	0.53	64.1	1.1
5.50	0.29	77.2	10.11	3.20	-82.5	0.09	-111.1	0.58	35.8	1.1
6.00	0.32	56.3	8.80	2.75	-102.6	0.09	-124.6	0.63	17.8	1.2
6.50	0.34	37.5	7.53	2.38	-121.6	0.09	-138.0	0.67	2.8	1.2
7.00	0.36	18.4	6.32	2.07	-140.1	0.09	-151.5	0.70	-10.6	1.2
7.50	0.40	-0.7	5.16	1.81	-158.1	0.08	-165.1	0.72	-23.4	1.3
8.00	0.45	-17.4	3.97	1.58	-175.4	0.08	-178.9	0.72	-36.1	1.3
8.50	0.51	-30.7	2.70	1.36	168.1	0.08	167.9	0.73	-49.0	1.4
9.00	0.56	-40.7	1.33	1.17	152.8	0.08	155.3	0.74	-61.4	1.5
9.50	0.61	-48.9	-0.14	0.98	138.6	0.07	143.6	0.76	-72.8	1.6
10.00	0.64	-56.6	-1.67	0.83	125.6	0.07	132.5	0.79	-82.7	1.7
10.50	0.66	-65.3	-3.21	0.69	113.2	0.06	121.9	0.82	-90.7	1.8
11.00	0.68	-75.6	-4.75	0.58	101.1	0.06	111.2	0.84	-97.7	1.9
11.50	0.70	-87.3	-6.24	0.49	88.9	0.05	100.1	0.86	-104.5	2.1
12.00	0.72	-99.8	-7.67	0.41	76.1	0.05	88.3	0.87	-111.9	2.4
12.50	0.75	-111.7	-8.99	0.36	63.2	0.04	76.2	0.88	-120.0	2.6
13.00	0.78	-121.6	-10.16	0.31	50.8	0.04	64.6	0.88	-128.5	2.8
13.50	0.80	-129.0	-11.18	0.28	39.5	0.04	53.9	0.88	-137.2	2.9
14.00	0.81	-134.2	-12.03	0.25	29.4	0.04	44.5	0.88	-145.6	3.1
14.50	0.82	-138.3	-12.76	0.23	20.4	0.04	36.0	0.89	-153.2	3.2
15.00	0.81	-142.2	-13.39	0.21	11.9	0.04	28.1	0.90	-159.9	3.3
16.00	0.79	-154.7	-14.65	0.19	-5.6	0.04	14.1	0.90	-171.9	4.4
17.00	0.79	-172.2	-15.80	0.16	-22.2	0.04	5.3	0.91	176.3	4.4
18.00	0.81	172.5	-16.95	0.14	-38.8	0.04	-7.8	0.91	164.4	4.4
19.00	0.81	160.6	-17.74	0.13	-54.3	0.04	-20.5	0.91	150.8	4.8
20.00	0.78	146.9	-18.25	0.12	-70.0	0.05	-32.9	0.90	136.6	5.6

Notes:

1. S-parameters are measured on a CPWG line fabricated on 0.025 inch thick Rogers® RO4350 material. The input reference plane is at the end of the input lead. The output reference plane is at the end of the output lead.

AVT-55689 Typical Scattering Parameters $T_A = 25^\circ C$, $Z_0 = 50 \Omega$, $V_{CC} = 5.5 V$, (unless specified otherwise)

Freq (GHz)	S11		S21		S12		S22		K	
	mag	angle	dB	mag	angle	mag	angle	mag		angle
0.05	0.07	-122.8	19.71	9.67	172.3	0.07	3.3	0.12	-50.2	1.0
0.10	0.05	-155.3	19.56	9.51	171.8	0.07	0.4	0.09	-43.1	1.1
0.50	0.03	109.9	19.33	9.25	151.4	0.07	-9.7	0.11	-70.8	1.1
0.90	0.04	9.0	18.97	8.89	129.8	0.07	-17.6	0.18	-96.2	1.1
1.50	0.08	-51.4	18.22	8.15	98.3	0.07	-28.2	0.23	-131.0	1.1
2.00	0.11	-83.1	17.44	7.45	73.0	0.07	-36.5	0.28	-162.9	1.1
2.50	0.13	-110.3	16.56	6.73	48.7	0.07	-44.5	0.33	169.4	1.1
3.00	0.14	-136.6	15.62	6.04	25.4	0.07	-53.1	0.38	144.3	1.1
3.50	0.15	-167.0	14.65	5.40	2.7	0.08	-62.4	0.43	121.2	1.1
4.00	0.17	159.3	13.65	4.81	-19.4	0.08	-72.8	0.47	99.9	1.1
4.50	0.21	130.3	12.59	4.26	-40.8	0.08	-84.0	0.50	80.9	1.1
5.00	0.25	109.6	11.53	3.77	-61.2	0.09	-95.6	0.52	64.1	1.1
5.50	0.30	76.1	10.23	3.25	-83.8	0.09	-110.6	0.57	35.7	1.1
6.00	0.33	55.2	8.91	2.79	-103.9	0.09	-124.1	0.62	17.8	1.2
6.50	0.36	36.3	7.62	2.40	-123.0	0.08	-137.4	0.66	2.8	1.2
7.00	0.38	17.3	6.39	2.09	-141.4	0.08	-150.9	0.69	-10.6	1.2
7.50	0.41	-1.7	5.21	1.82	-159.4	0.08	-164.7	0.71	-23.4	1.3
8.00	0.46	-18.4	4.00	1.59	-176.8	0.08	-178.4	0.72	-36.1	1.4
8.50	0.52	-31.6	2.72	1.37	166.7	0.08	168.4	0.72	-48.9	1.4
9.00	0.57	-41.6	1.34	1.17	151.5	0.08	155.9	0.73	-61.3	1.5
9.50	0.61	-49.7	-0.14	0.98	137.4	0.07	144.2	0.76	-72.7	1.6
10.00	0.64	-57.4	-1.67	0.82	124.3	0.07	133.2	0.78	-82.5	1.7
10.50	0.66	-66.1	-3.22	0.69	112.0	0.06	122.5	0.81	-90.6	1.8
11.00	0.68	-76.3	-4.76	0.58	100.0	0.06	111.8	0.84	-97.6	2.0
11.50	0.70	-88.0	-6.26	0.49	87.7	0.05	100.6	0.86	-104.5	2.2
12.00	0.72	-100.4	-7.69	0.41	75.0	0.05	88.9	0.87	-111.8	2.4
12.50	0.75	-112.2	-9.01	0.35	62.1	0.04	76.8	0.87	-119.9	2.6
13.00	0.78	-122.1	-10.19	0.31	49.7	0.04	65.1	0.88	-128.4	2.9
13.50	0.80	-129.5	-11.20	0.28	38.4	0.04	54.5	0.88	-137.2	3.0
14.00	0.81	-134.7	-12.06	0.25	28.4	0.04	44.9	0.88	-145.6	3.1
14.50	0.82	-138.7	-12.78	0.23	19.3	0.04	36.5	0.89	-153.2	3.2
15.00	0.81	-142.7	-13.40	0.21	10.8	0.04	28.6	0.89	-159.8	3.4
16.00	0.79	-155.1	-14.67	0.18	-6.7	0.04	14.7	0.90	-171.9	4.5
17.00	0.79	-172.7	-15.83	0.16	-23.4	0.04	5.6	0.91	176.3	4.6
18.00	0.81	172.2	-16.98	0.14	-39.9	0.04	-7.6	0.91	164.5	4.6
19.00	0.81	160.3	-17.79	0.13	-55.6	0.04	-20.4	0.90	150.8	5.0
20.00	0.78	146.5	-18.31	0.12	-71.3	0.05	-32.8	0.90	136.5	5.8

Notes:

1. S-parameters are measured on a CPWG line fabricated on 0.025 inch thick Rogers® RO4350 material. The input reference plane is at the end of the input lead. The output reference plane is at the end of the output lead.

Package Dimensions

Dimensions are in mm

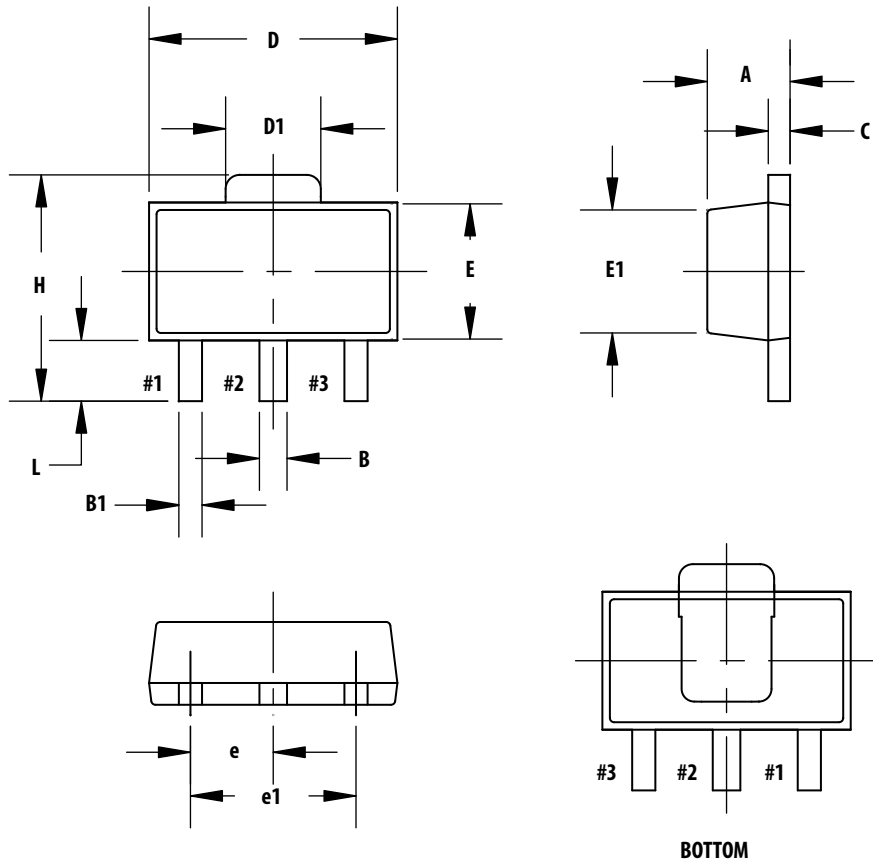

BOTTOM

SYMBOL	COMMON					
	DIMENSIONS MILLIMETER			DIMENSIONS INCH		
	MIN.	NOM.	MAX.	MIN.	NOM.	MAX.
A	1.40	1.50	1.60	0.055	0.059	0.063
B	0.44	0.50	0.56	0.017	0.0195	0.022
B1	0.36	0.42	0.48	0.014	0.0165	0.019
C	0.35	0.40	0.44	0.014	0.016	0.017
D	4.40	4.50	4.60	0.173	0.177	0.181
D1	1.62	1.73	1.83	0.064	0.068	0.072
E	2.30	2.50	2.60	0.090	0.096	0.102
E1	2.13	2.20	2.29	0.084	0.087	0.090
e	1.50 BSC			0.059 BSC		
e1	3.00 BSC			0.118 BSC		
H	3.95	4.10	4.25	0.155	0.161	0.167
L	0.90	1.10	1.20	0.035	0.038	0.047

Notes :

1. Dimensioning and tolerancing per ANSI.Y14.5M-1982.
2. Controlling dimension: Millimeter conversions to inches are not necessarily exact.
3. Dimension B1, 2 places.
4. Lead coplanarity control below 4 mil.

Part Number Ordering Information

Part Number	No. of Devices	Container
AVT-55689-BLKG	100	Antistatic Bag
AVT-55689-TR1G	3000	13" Tape/Reel

Device Orientation

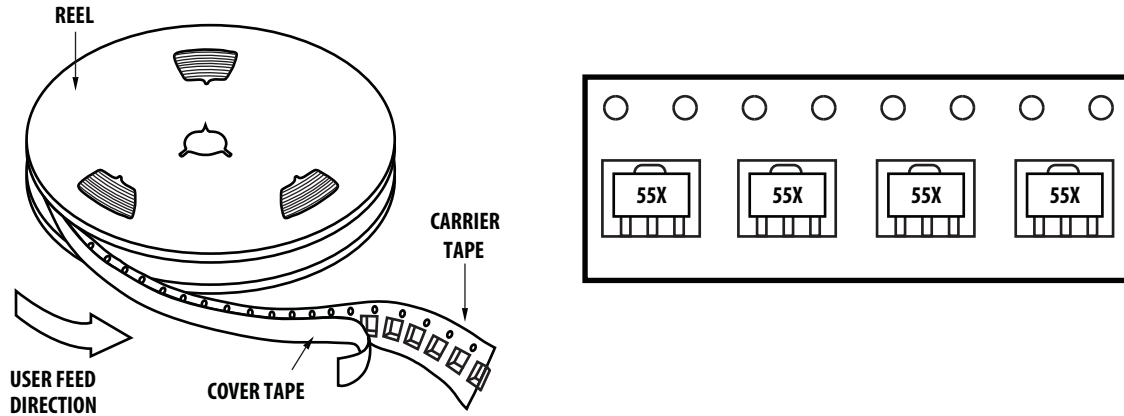

Tape Dimensions

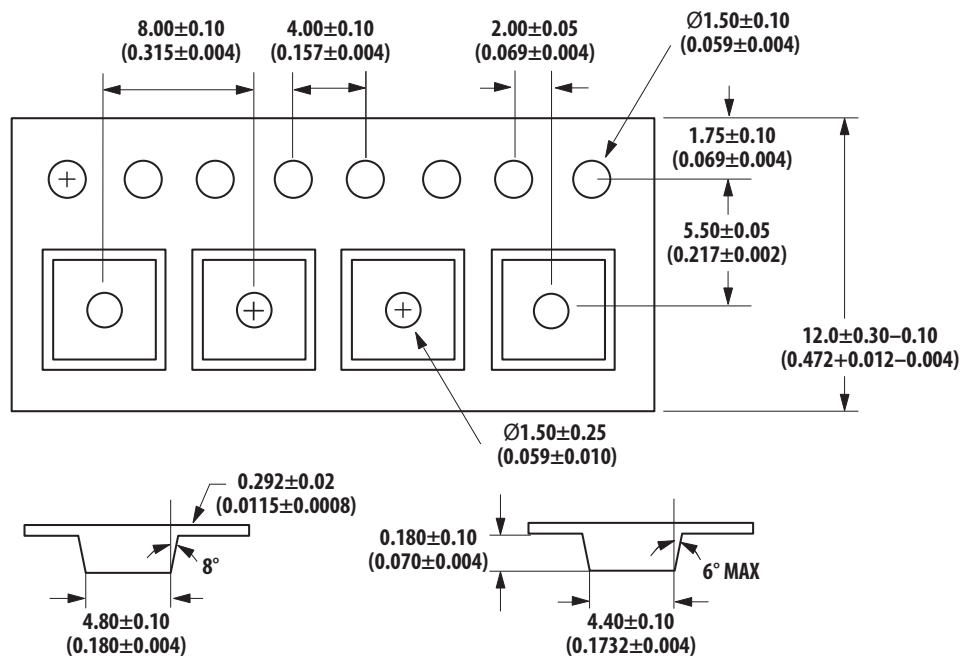

Dimensions in mm (inches)

