

CIRCUIT POSITIONS	PLUG ASSY●■	CAP ASSY●■	PERIPHERAL SEAL
2 S	776427	776428	776425-1
3 S	776429	776430	776425-2
4 D	776487	776488	776425-4
6 D	776433	776434	776425-5
8 D	776494	776495	776425-6
12 D	776437	776438	776425-8

- Assembly dash number indicates color and keying position (-1 Red, -2 Gray, -3 Yellow, -4 Green)
 - Call PRODUCT INFORMATION at the number at the bottom of this page for product availability.
- S = Single Row D = Dual Row

Figure 1

1. INTRODUCTION

This instruction sheet provides assembly and disassembly procedures for the connectors listed in Figure 1. The plug and cap housing assemblies are available in 2 through 12 circuit versions and are intended for wire-to-wire applications.

NOTE



Dimensions in this instruction sheet are in millimeters [with inches in brackets]. Figures and illustrations are for reference only and are not drawn to scale.

Reasons for reissue of this instruction sheet are provided in Section 8, REVISION SUMMARY.

2. DESCRIPTION

A connector assembly consists of a plug assembly loaded with size 16 socket contacts, mated to a cap assembly loaded with size 16 pin contacts. Circuit identification is marked on each housing. Four different keying configurations are available (color and mechanical).

An integral connector position assurance (CPA) is designed on each cap assembly and both assemblies have a terminal position assurance (TPA) feature to lock the contacts in the housings. Sealing plugs are available for unused circuits. Moisture resistance is provided through the use of wire seals and a peripheral seal in the interface area.

3. CONTACTS (Figure 2)

The heavy duty stamped and formed (HDSF) size 16 pin and socket contacts accept wire sizes 14 through 20 AWG. The connectors will seal properly to wires having insulation diameters from 1.96–3.94 mm [.077–.155 in.]. Refer to Application Specification 114–13045 for information on contacts and application tooling.

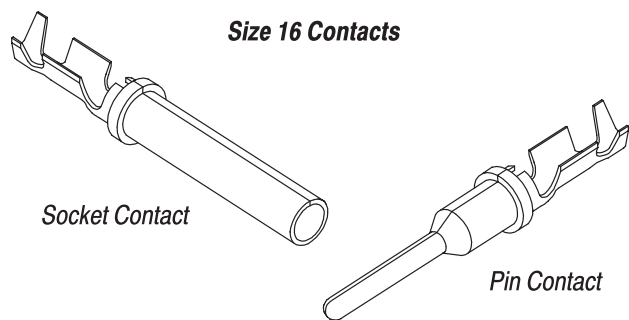

Figure 2

4. ASSEMBLY PROCEDURES

Before manually loading the crimped contacts into the housing assemblies, verify that the TPA is in the pre-staged position (see Figure 3).

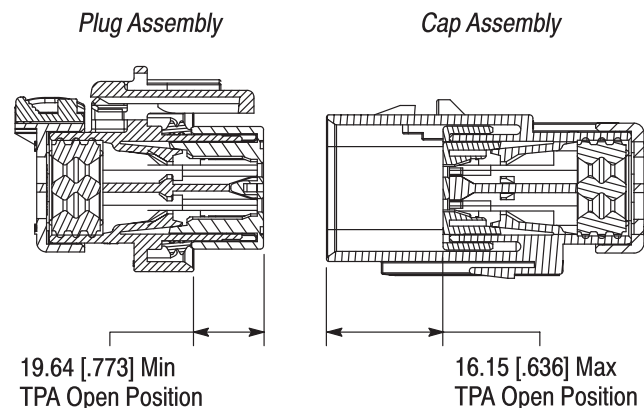

Figure 3

1. Align the contact with the desired circuit cavity at the rear of the housing assembly (socket contacts with plug assemblies and pin contacts with cap assemblies).
2. Push the contact straight into the cavity, forcing it through the wire seal. Continue to push the contact until the contact retention finger returns to its normal position behind the retention shoulder on the contact. See Figure 4.

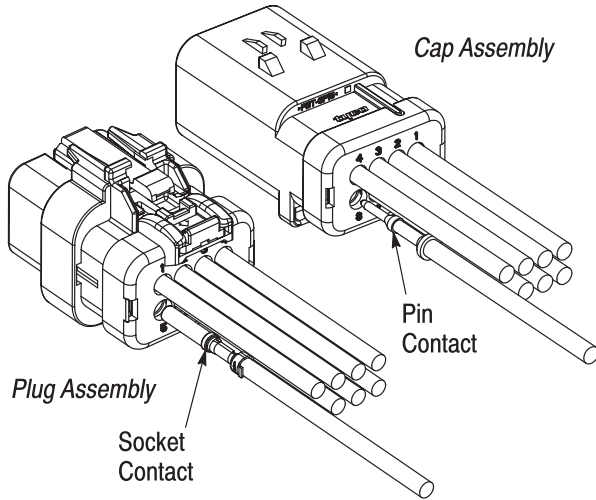

Figure 4

3. When all of the required contacts have been inserted, complete the assembly by pushing the TPA into the fully locked position. See Figure 5.
 - a. The TPA on the plug assembly may be fully locked by holding the rear of the assembly and pushing the TPA toward the rear of the assembly.
 - b. The TPA on the cap assembly must be locked in place using the Contact/TPA Removal Tool 776441-1 (or a reasonable substitute such as a small, flat-blade screwdriver). Insert tip of Removal Tool into removal tool slot of TPA, with notch in tool facing centerline of the TPA. Hook the notch of the removal tool against the edge of the slot in the TPA and push the TPA into the locked position.

If a substitute tool is used, the following method may be used to secure the TPA. Place the tip of the tool as near to the center of the TPA as possible. Make sure the tip is turned 90° to any grooves on the top of the TPA. Push the TPA into the cap assembly until you feel it move into the locked position.

4. Verify that all contacts are locked in place by giving a slight tug on each wire with a force between 4.5 and 8.9 N [1 and 2 lb-f].

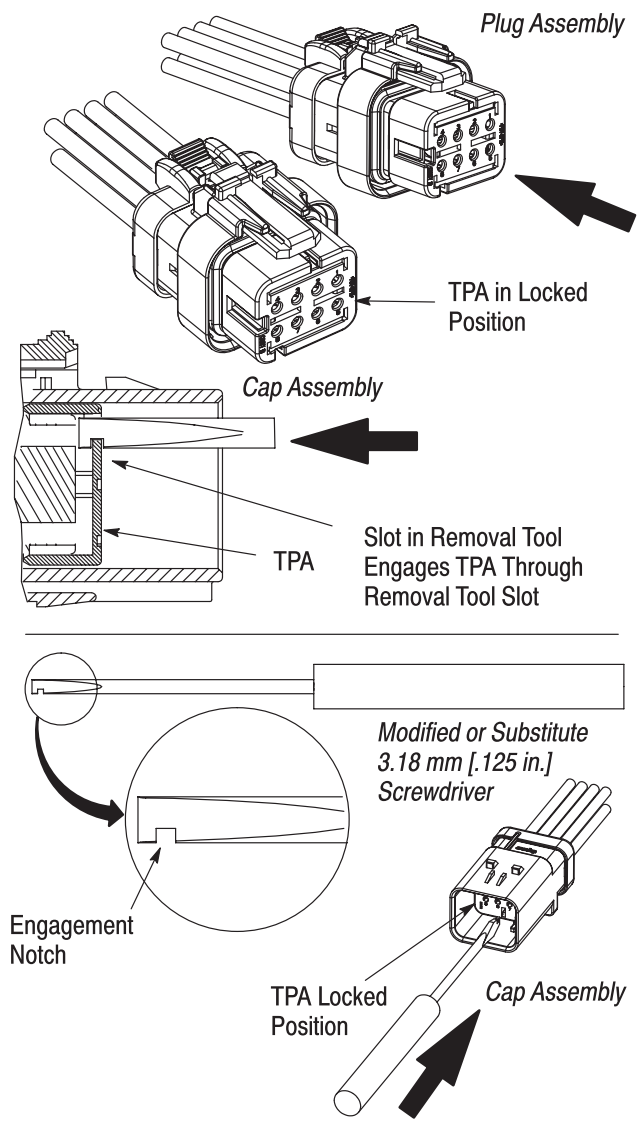

Figure 5

5. Place a sealing plug (part number 776363-1) into any unused circuits. The sealing plug should be pushed into the wire entry end of the plug or cap assembly until the sealing plug flange is firmly against the seal cover. See Figure 6.

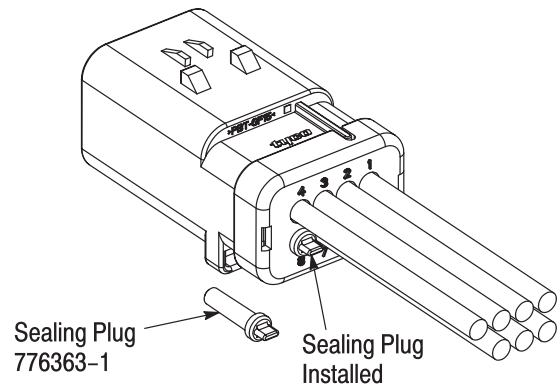

Figure 6

6. When all contacts have been locked securely in the assemblies, complete the connector system by mating the plug and cap until the connector latch is in the fully locked position. See Figure 7.

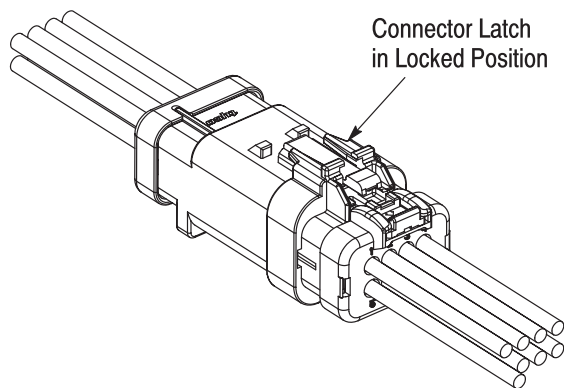

Figure 7

7. By pushing the CPA toward the plug housing, it can be slid into the locked position in which it covers the tip of the connector latch. See Figure 8.

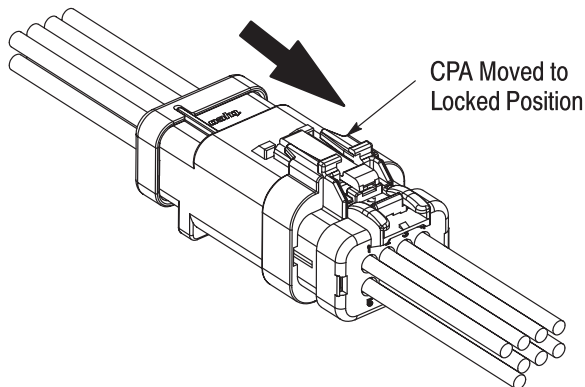

Figure 8

5. DISASSEMBLY PROCEDURES

Damaged or misplaced contacts can be removed and replaced as follows:

1. Slide the CPA toward the rear (wire end) of the cap assembly to reveal the connector latch tip.
2. Simultaneously depress the end of the connector latch and pull on the rear of the plug assembly to separate the mated connector assembly. See Figure 9.
3. Orient the contact/TPA removal tool (or equivalently modified 3.18 mm [.125 in.] screwdriver) so that the slot in the tool is facing the centerline of the TPA. Insert the removal tool into the extraction slot in the plug or cap assembly TPA as shown in Figure 10.

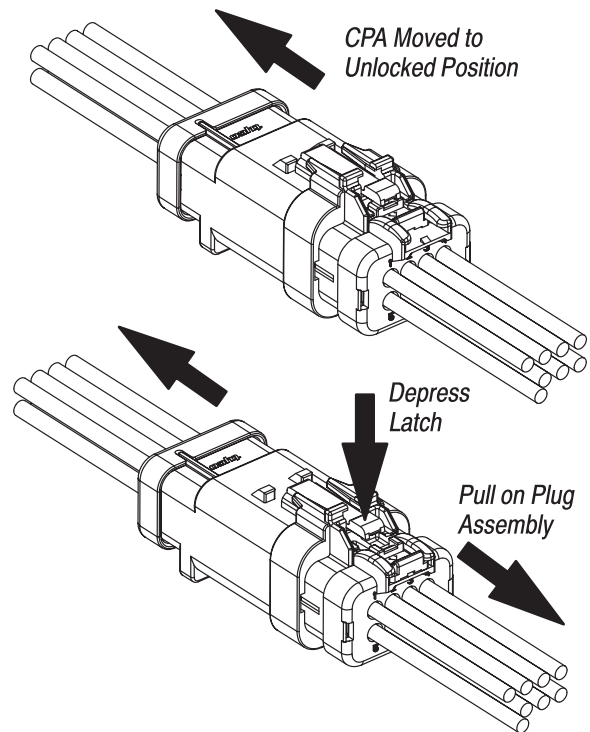

Figure 9

4. Hook the removal tool firmly against the edge of the slot and pull on the TPA until it is completely removed from the housing assembly. Retain the TPA for use with the connector assembly after the contacts are replaced.



CAUTION Do not remove the TPA in the plug assembly without using the extraction tool.

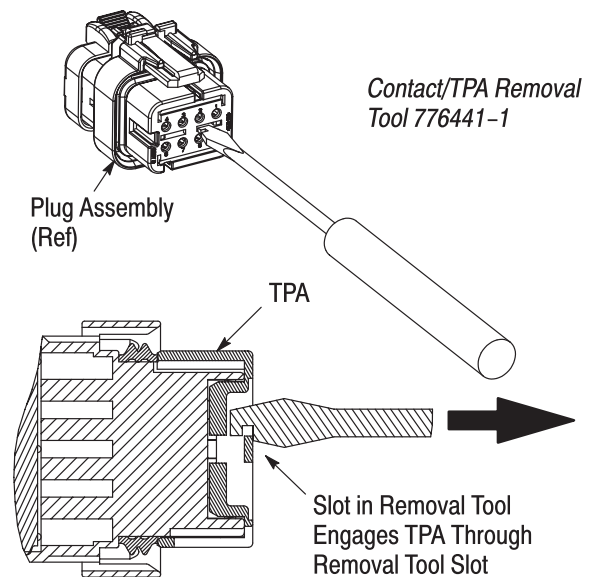

Figure 10

5. Insert the tip of the contact/TPA removal tool into the contact cavity and deflect the contact retention finger. Gently pull the wire until the contact is free from the housing. Repeat this procedure for the remaining number of contacts to be removed. See Figure 11.



Rotating the contacts to remove them from the housing without using the extraction tool may damage the housing resulting in reduced contact retention upon subsequent use of the housing.

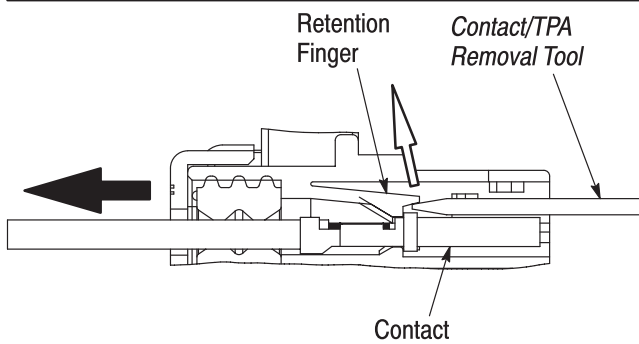

Figure 11

6. RE-ASSEMBLY OF CONNECTOR

To re-assemble the plug or cap assembly after servicing a contact, proceed as follows:

1. Align the keying features of the TPA with the appropriate features in the plug and cap housings. Place the TPA locking fingers inside the plug or cap housing.



Single row plug and cap assemblies are keyed by the location of the latching fingers of the TPA. A "V" shaped notch inside the housing keys the dual row plug and cap assemblies with a matching "V" shaped rib on the bottom of the TPA.

2. Push the TPA into the pre-staged position by using the extraction tool or manually by hand. Refer to Section 4 and Figure 3 to verify the correct position.
3. Complete the assembly according to Section 4.

7. PERIPHERAL SEAL REPLACEMENT

The peripheral seal (see Figure 1) can be replaced when the connector is separated for servicing. Proceed as follows:

1. Separate the connector system and remove the TPA from the plug assembly according to the procedures in Section 5, Steps 1 through 4.
2. The old seal may be removed by sliding it off the end of the plug housing.
3. The sealing surface of the plug housing should be cleaned to remove any dirt, moisture, or debris that may be on the connector assembly.
4. The new seal may be assembled to the plug assembly by sliding it on the end of the plug housing.



Care should be taken to make sure the seal does not roll during this process.

5. Re-assemble the TPA to the plug housing according to the steps outlined in Section 6.

8. REVISION SUMMARY

Revisions to this instruction sheet include:

- Updated document to corporate requirements
- Added "AMPSEAL 16" to product name
- Changed information in table in Figure 1
- Added new artwork to Figures 1, 3, 4, 5, 6, 7, 8, 9, and 10