



TRANSPORTATION SOLUTIONS

Panasonic Electric Works of America
<http://pewa.panasonic.com>



Panasonic ideas for life

Panasonic ideas for life

A History of Quality Products and a Long Partnership with the Automotive Industry

Panasonic has been contributing to the ever increasing need for innovation in transportation electronics for decades, with highly reliable, long lasting devices for transportation safety, comfort, entertainment and powertrain applications.

Panasonic Electric Works Corporation of America, based in New Providence, NJ, is proud to offer many automotive grade components in the U.S., Canada, Mexico and South America.

There is continued effort within the transportation industry to balance societal and economic pressures with the environment. Panasonic continually supports these efforts with proven quality, a solid manufacturing organization and experienced engineering talent.



Panasonic Electric Works Corporation of America

Creating New Opportunities in the Evolving Transportation Market

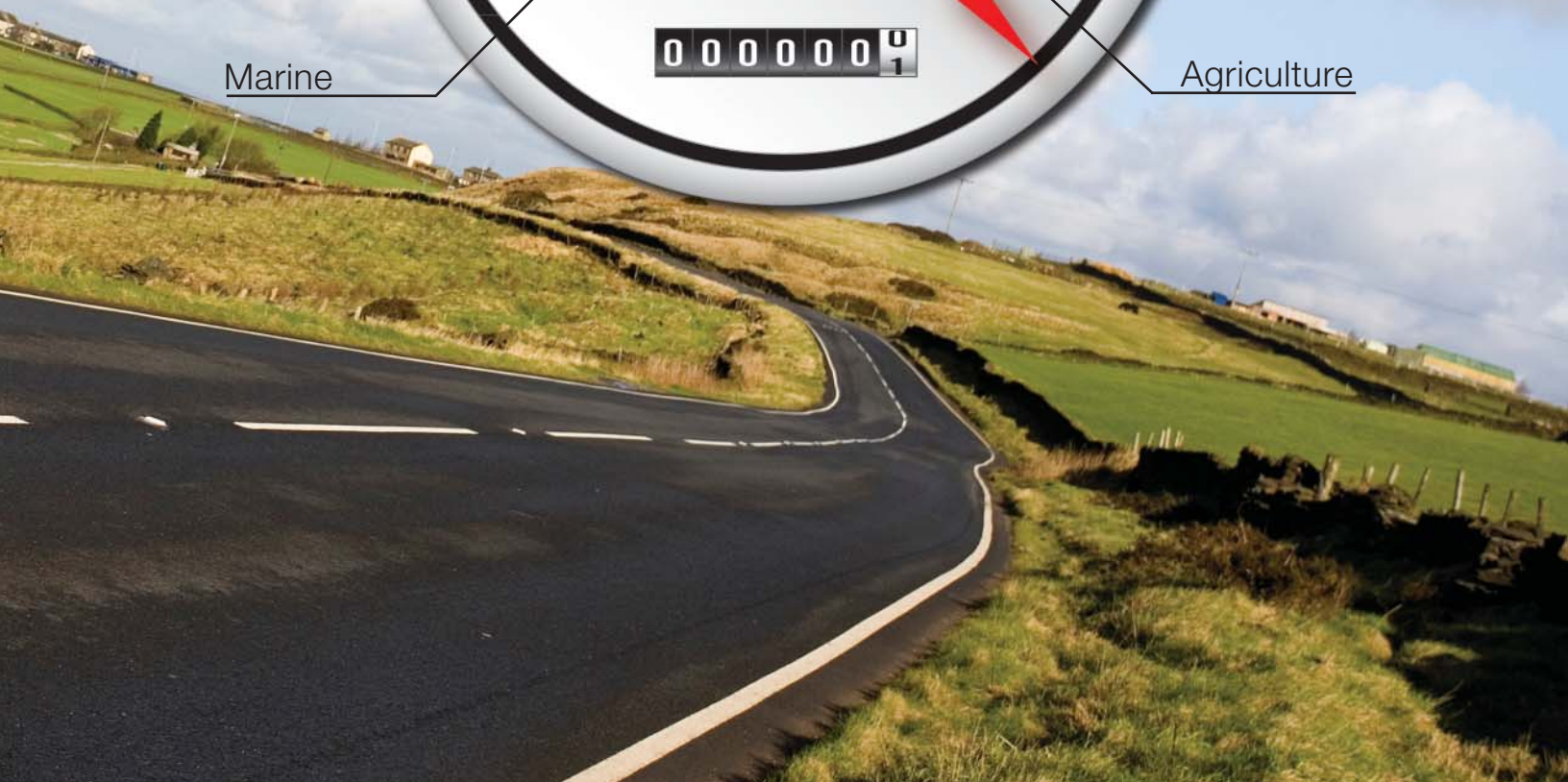
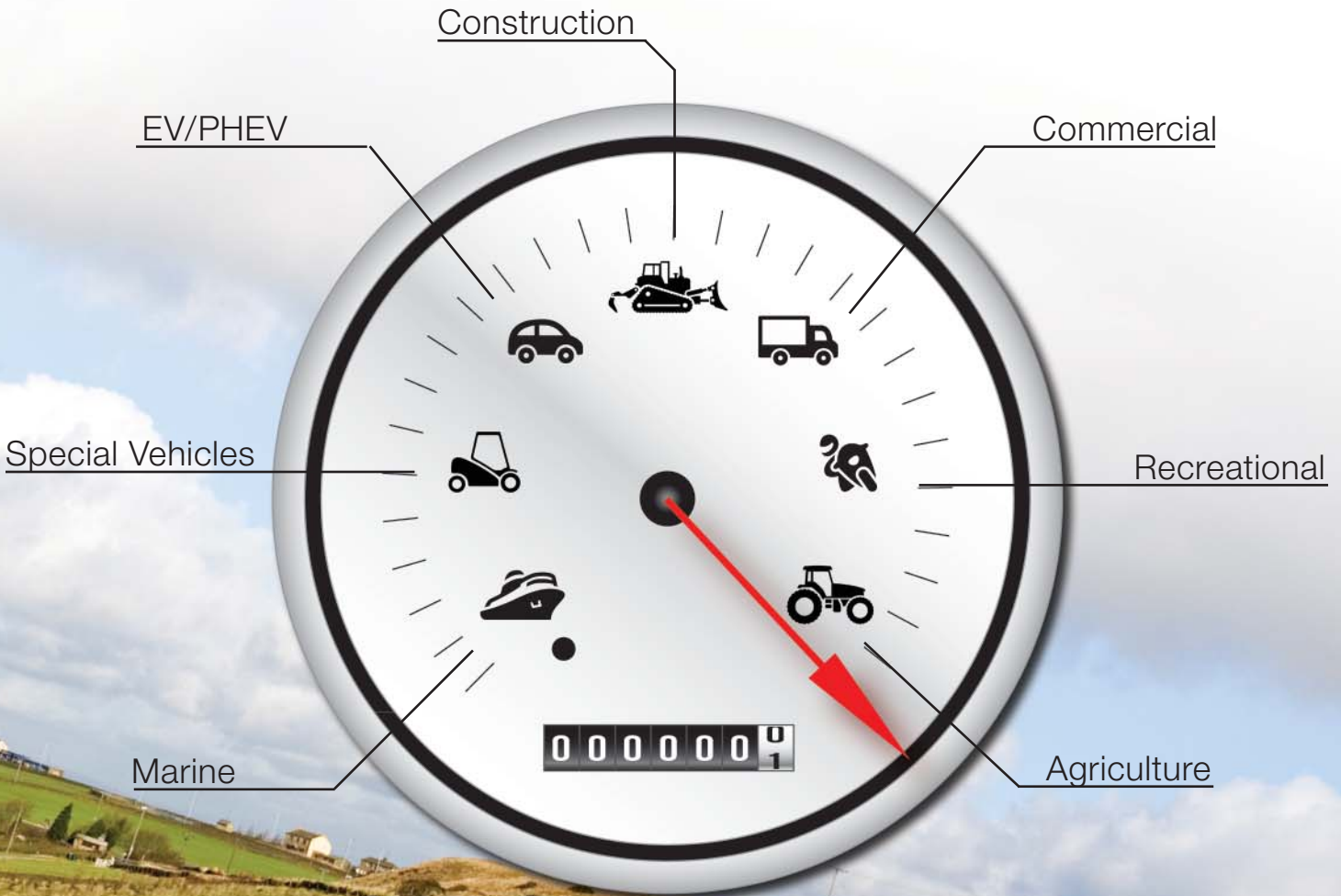

TRANSPORTATION SUBSYSTEMS

ELECTRIC VEHICLES

- LEV Power Supply
- EV/HEV Power Supply
- Battery Monitoring
- Main & Pre Charge

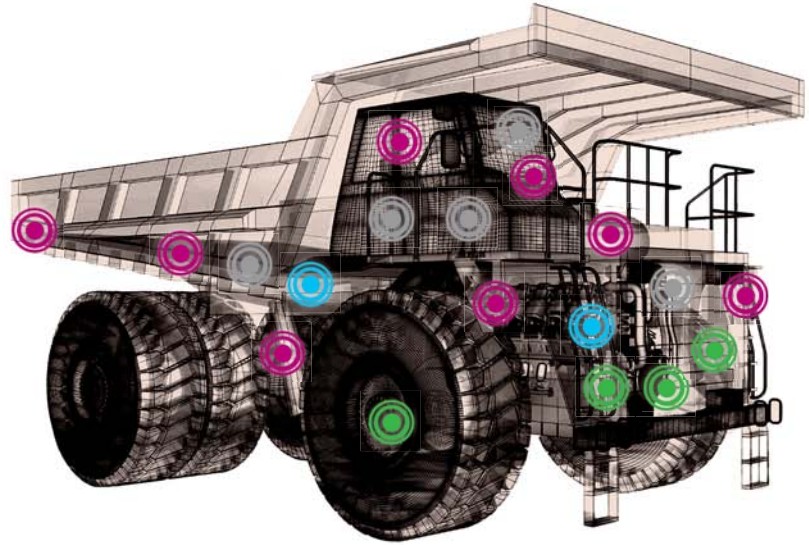

SAFETY

- Wipers
- EPS
- Flashers
- Horn
- Daytime Running Lights
- Obstacle Detection
- Headlights
- Power Windows
- Doors
- Sun Roof
- Defogger
- Gas Tank Cover

COMFORT

- Seat
- Navigation
- Sunroof
- Gas Tank Cover
- Windows
- Door Locks
- Cruise Control
- High Speed Fuel Injection Control
- AT Shift Lever Position Detection
- Key Rotation Detection
- Turn On Seat Belt Unfastened Warning Lamp
- Turn On Interior Lights
- Turn On Warning Lamp for Unclosed Door
- Close Door Automatically
- Power Window Safety Control

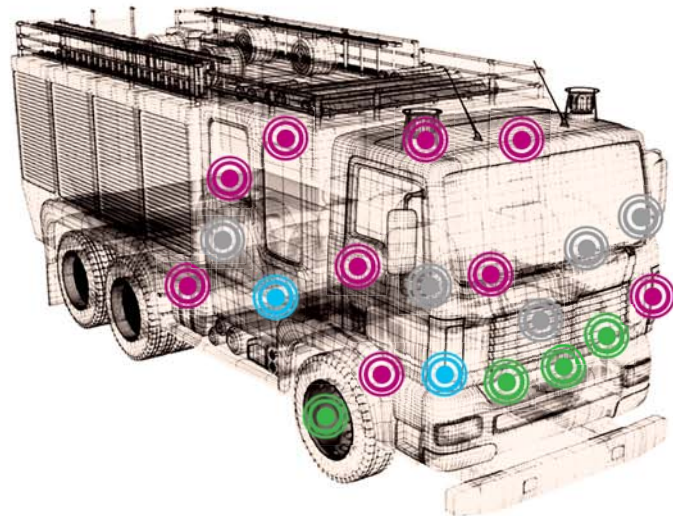

POWER TRAIN CONTROLS

- Transmission Range Detection
- Blower Fan
- ABS / TRC
- EPS
- Radiator Fan Motor
- Starter Motor

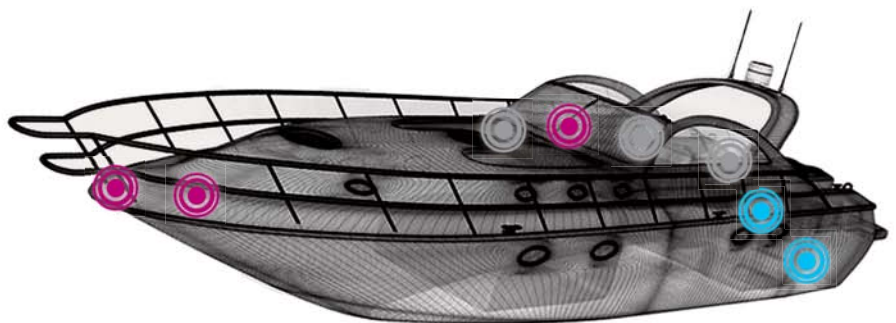
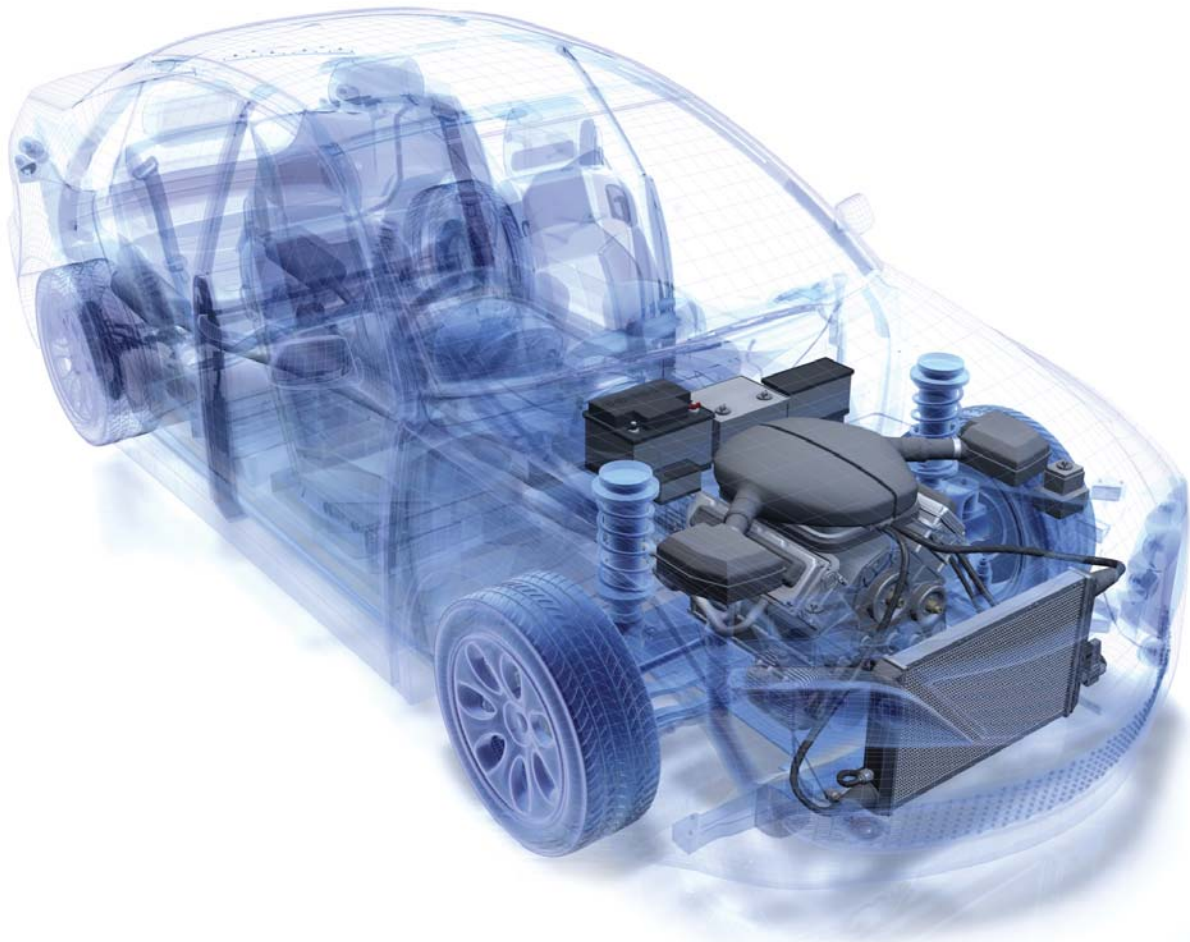

TABLE OF CONTENTS

Electrification of Vehicles	6-8	Stop Idle Systems	19	Relay Specifications	26-28
EV: Main & Pre Charge Relays	9-10	EV Charging Station	20	Quality Control & Certifications	29
EV Relay Design Considerations	11-14	Door Locks & Power Windows	21	Sealed Switches	30-31
PhotoMOS & Leak Detection	15	Wipers & Washer Fluid Pumps	22	Tomorrow's Vehicle Electrification	32
Battery Management	16	Electric Power Steering	23	Design Considerations	33-35
Battery Leakage/Balance	17	Tilt Sensor Applications	24		
Battery Charging/Discharging	18	Automotive Relay Overview	25		



ELECTRIFICATION OF VEHICLES

VEHICLE ENERGY STORAGE

Automotive batteries play an important role in the design and development of electric, hybrid and plug-in hybrid electric vehicles. Batteries used in electric vehicles are larger in size, carry higher voltages and are more complex in design than the conventional Lead-acid batteries used with combustion engines.

In combustion engines, batteries are designed to be fully charged when starting the vehicle. After starting the vehicle, the lost charge is replaced by an alternator so that the battery remains fully charged.

Shown on the right are the three battery technologies being used and considered for electric propulsion:

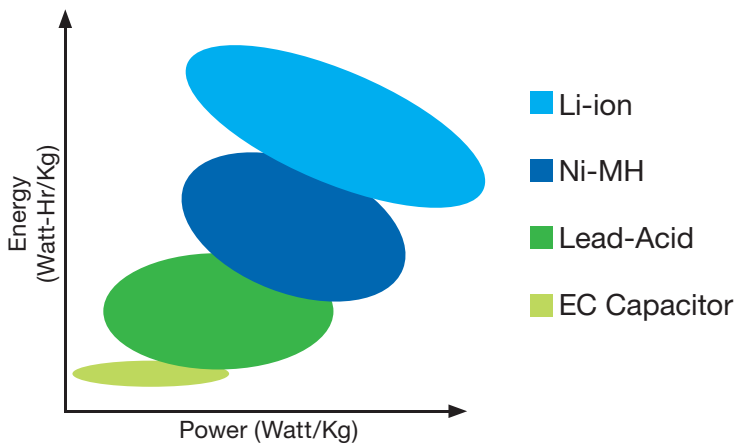

Lead-Acid



Ni-MH



Li-Ion

Electric vehicles use energy from the battery to assist vehicle propulsion. Below is an example of an electric system drive, where the power electronics converts direct current (DC) from the battery to alternating current (AC) and sends it to the motor.

The electric motor uses AC current to create torque (mechanical power) to power the wheels for propulsion. The electric motor, in turn, can also send energy back through the inverter and into the battery for recharging. This acts as a generator and can help the vehicle decelerate when slowing down or coming to a stop.

Lead Acid (PbA):

- Common with combustion engine vehicles
- Back up emergency power
- Small motorized special vehicles: fork lifts, golf carts, etc.

Nickel-Metal-Hydride (Ni-MH):

- Rechargeable
- Similar to Nickel-Cadmium Cells
- Cell Phones
- Power Tools

Lithium-ion (Li-Ion):

- Lightweight
- Rechargeable
- High Energy Content

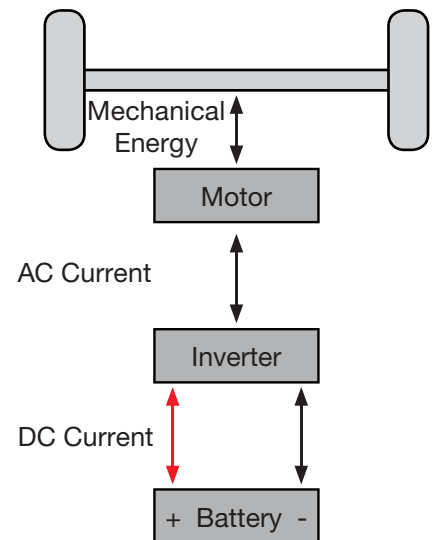

Simple HEV Power Drive System

ELECTRIFICATION OF VEHICLES

Electric Vehicles use batteries to power an electric motor to propel the vehicle. Batteries are recharged from regenerative braking or from an external source (i.e. grid or charging station). Battery driven vehicles today include passenger cars, neighborhood electric vehicles and off-road industrial equipment such as forklifts and golf carts.

Hybrid Electric Vehicles (HEVs) combine the Internal Combustion Engine of a conventional vehicle with the High-Voltage Battery and electric motor of an Electric Vehicle.

Plug-in Hybrid Electric Vehicles (PHEV) combine the propulsion of a combustion engine with an electric motor. PHEV uses the same technology as an HEV but with much larger high-voltage batteries to power the electric motor and has a longer all-electric range. But, unlike the batteries in the HEV, which are recharged by only the internal combustion engine, (and other technologies), the batteries in PHEVs can also be recharged by using an external power source, such as a home or office electrical outlet.

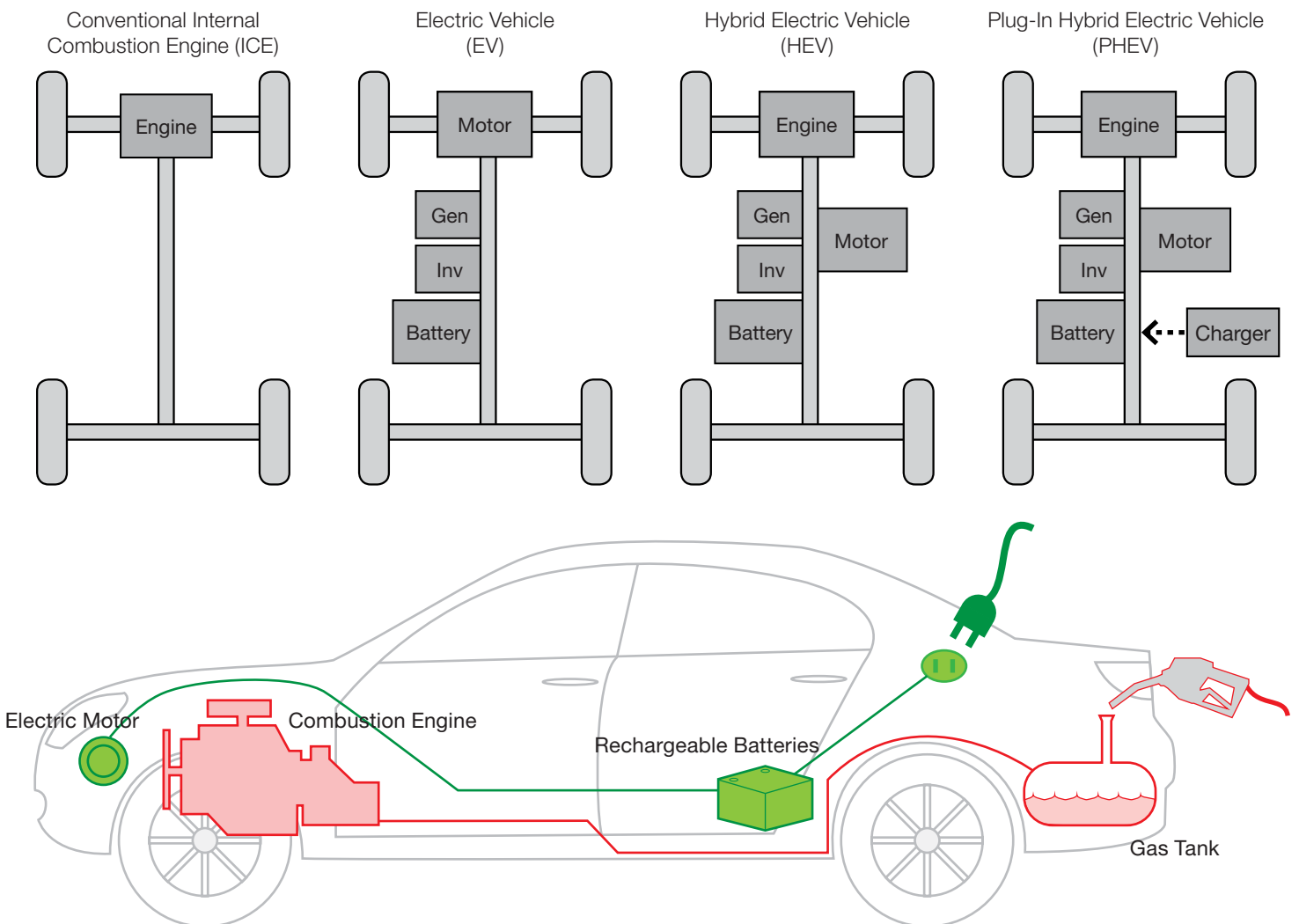

ELECTRIFICATION OF VEHICLES



A Engine: The engine burns fuel and converts it into mechanical energy to power the vehicle.

B/C Motor/Generator: Converts electrical energy to mechanical energy to power the wheels. It also acts as a generator to create electricity from mechanical torque (from the wheels) during Regenerative Braking.

D Power Electronics Unit: Power electronic systems, such as converters and inverters, receive information from sensors to control power management.

E Inverter: The inverter is a device that converts direct current (DC) into alternating current (AC). Electric and hybrid electric vehicles are powered by an electric motor and the inverter helps supply that motor with DC and AC current. In addition, the inverter can also step up the DC voltage coming from the battery when higher power ratings are required.

F Battery: The Battery system stores electricity from the generator, which helps power the motor and other auxiliary electrical devices.

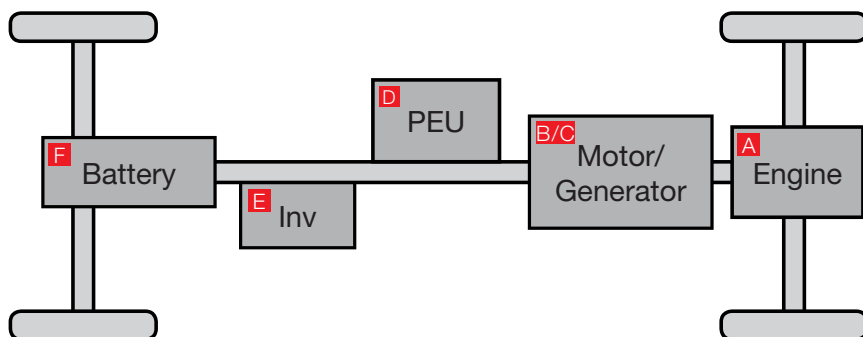

EV: MAIN & PRE-CHARGE RELAYS

A Pre-Charge relay is necessary to help prevent the full inrush current (I_s) going through the Main Relays which can cause contacts to weld.

- Main relay 1 and main relay 3 close allowing current to go through and charge the capacitor.
- When the capacitor reaches 90% capacity, then relay 2 opens.
- When this occurs, relay 3 closes simultaneously allowing full current to go to the inverter.

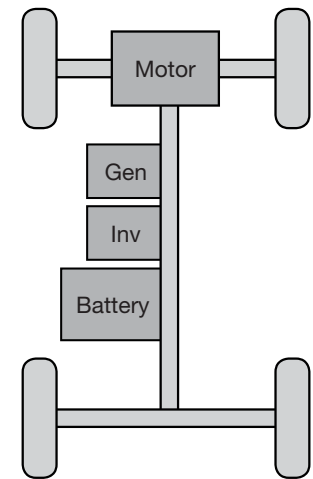
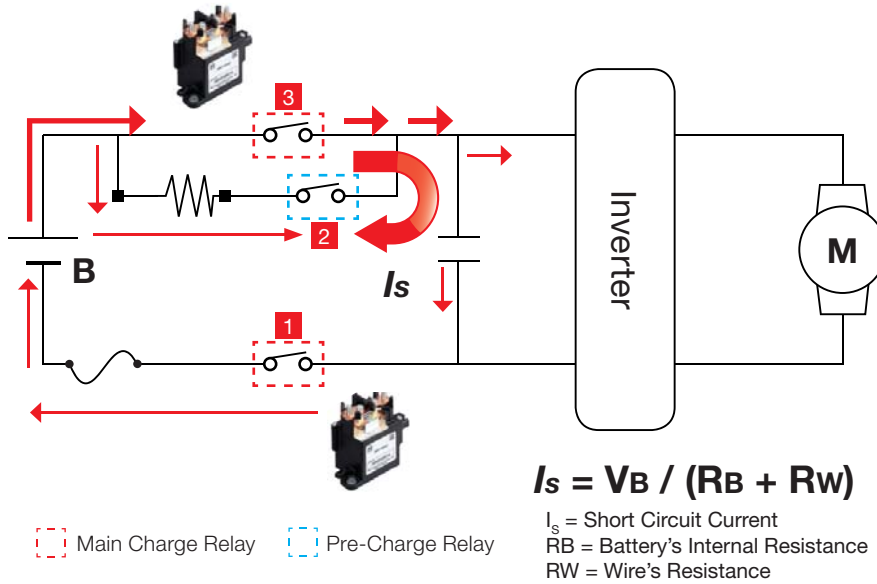

TYPICAL RELAY TIMING CHART

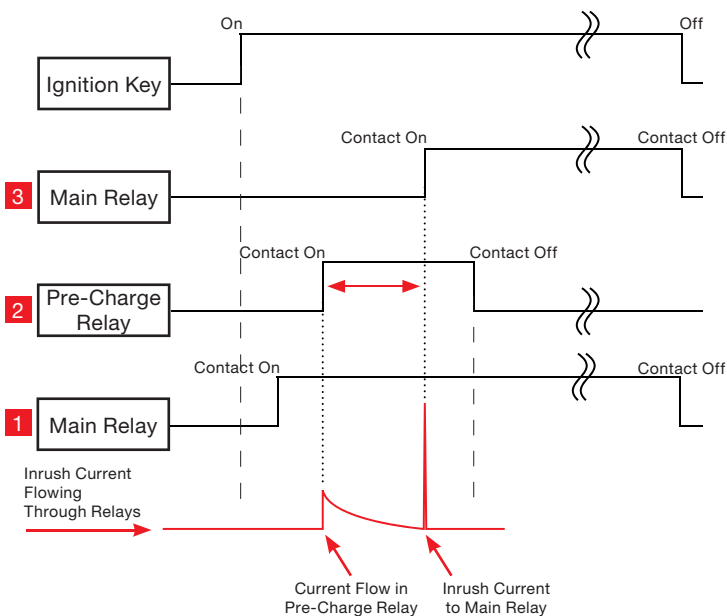

EMERGENCY CUTOFF

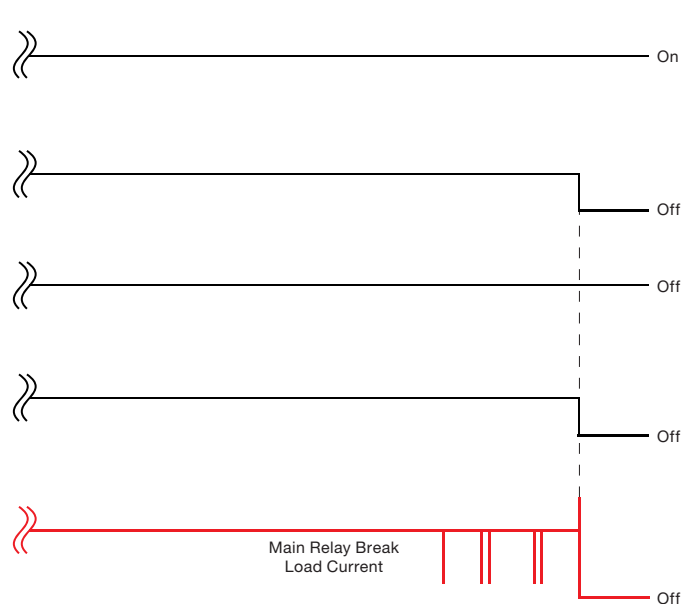

EV: MAIN & PRE-CHARGE RELAYS

EV RELAY OPERATION

When the circuit to an inductive load is opened, much of the energy stored in the load must be dissipated as arcing at the contacts. This arc expands due to the presence of a magnetic field, which is used to weaken the arc. To weaken it even further, Panasonic uses inert gases (H_2) which rapidly gets extinguished.

Typical voltage drop is approximately 400V DC.

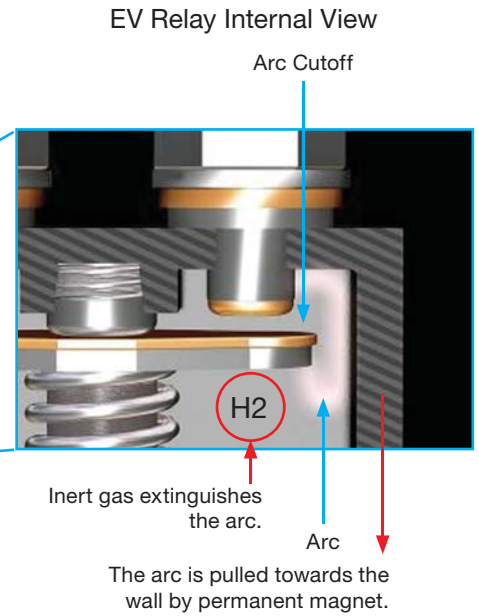
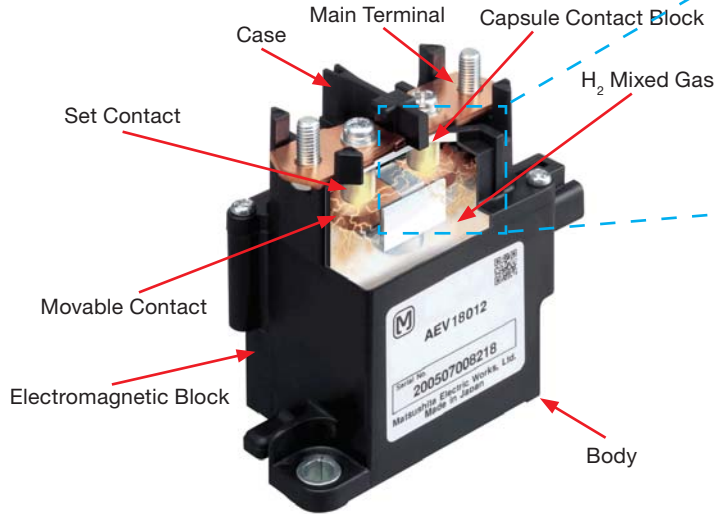

HYDROGEN ENCAPSULATION MECHANISM

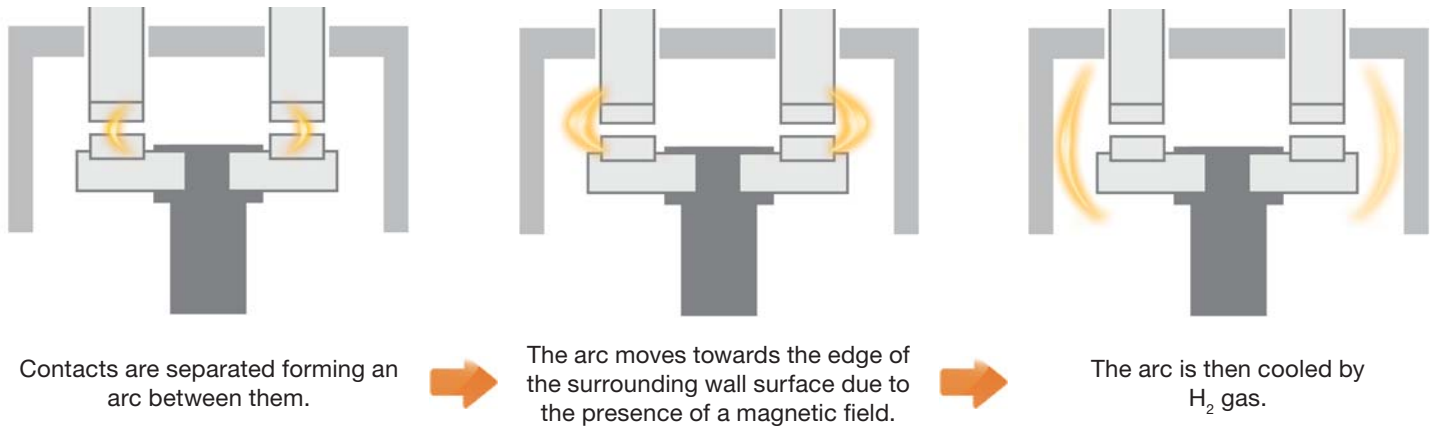

WHY USE H₂ INSTEAD OF OTHER GASES?

In order to assure a quick cut off of the arc, the arc voltage component needs to be very “high”. For the same power dissipation, the current component needs to become smaller, making the arc easier to extinguish. The example can be easily shown using the following basic power formula: $P = VI$, where voltage (V) goes up and current (I) goes down.

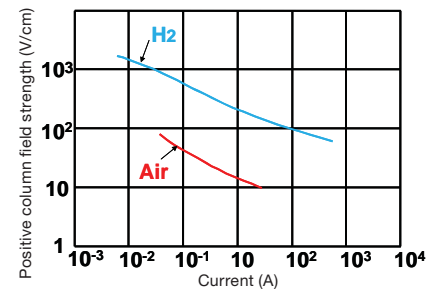

EV RELAY DESIGN CONSIDERATIONS

AVOIDING RELAY CONTACT WELDING/EXPLOSION

When designing for Short-Circuit protection one needs to consider three key factors:

1. Wire Harness
2. Fuse
3. DC Power Relay

Over-current conditions can cause damage to electrical components and wiring. Before designing a system the designer needs to ensure that:

- The FUSE opens BEFORE the RELAY contacts weld or destroy themselves
- The RELAY is inoperative BEFORE the WIRING is affected

Failure should occur in the following order:

1. FUSE → 2. RELAY → 3. WIRING

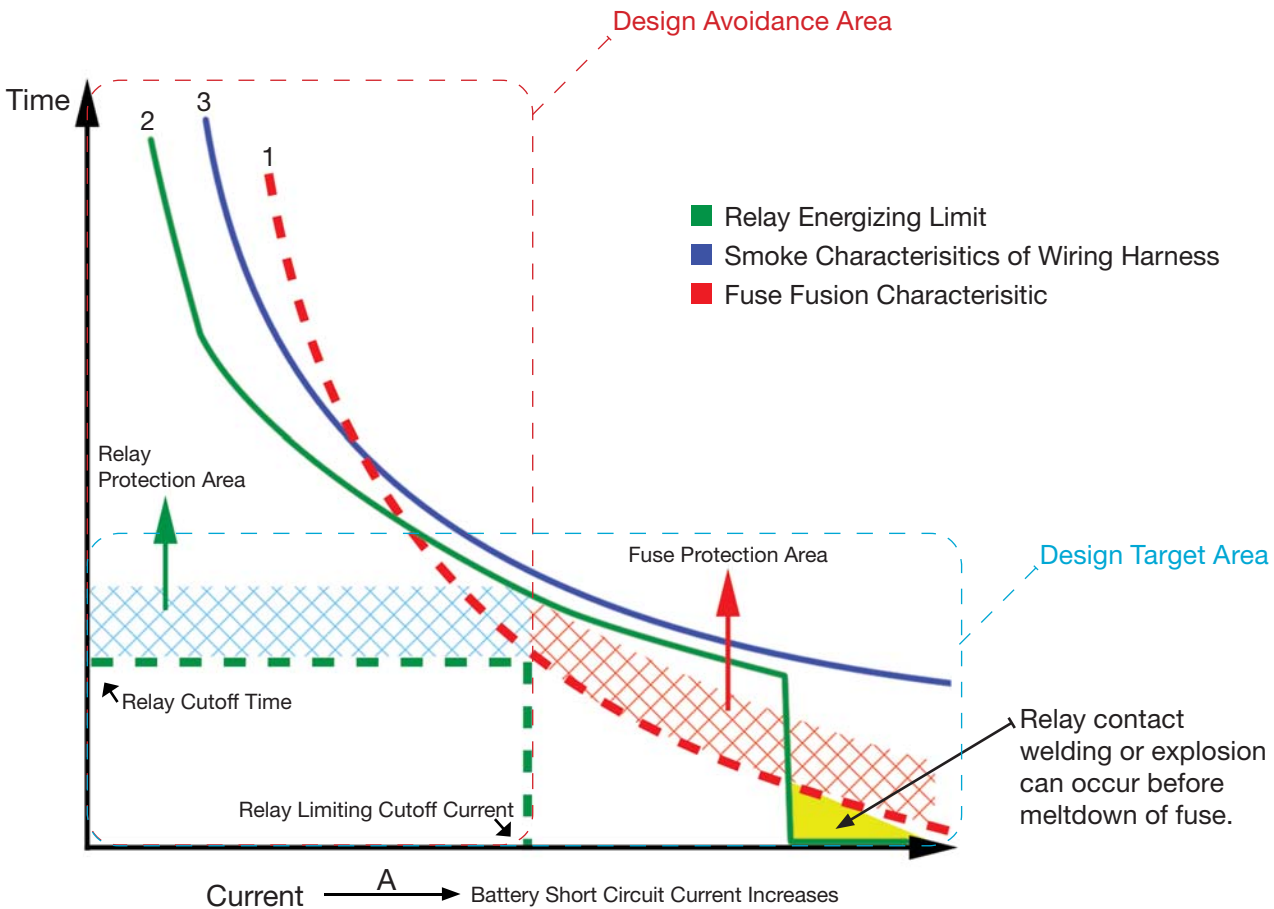

EV RELAY DESIGN CONSIDERATIONS

DESIGNING AVERAGE vs. PEAK CURRENT

Measuring the State Of Charge (SOC) in EV, HEV or PHEV batteries is a good way to determine how well a battery performs. At times referred to as the battery “fuel gauge”, the SOC is also used to determine the end of charging and discharging cycles, often defined in terms of current capacity.

Hybrid vehicle batteries require both high power charge capabilities for regenerative braking and high power discharge capabilities for boosting.

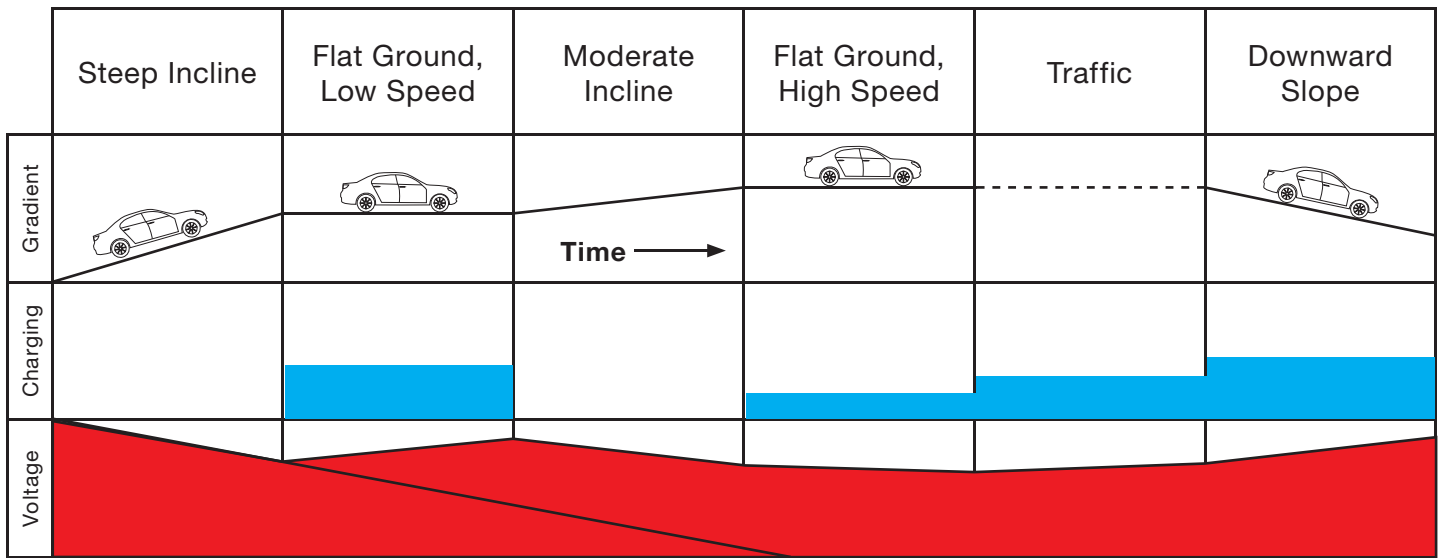

Battery voltage can become completely depleted if not re-charged while driving up a steep incline in full acceleration mode.

Main/Pre Charging relays help safely manage inrush currents.

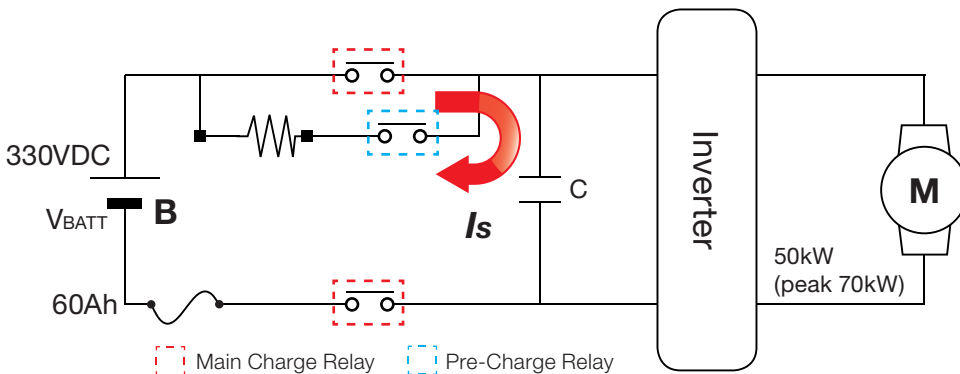

Main Relay

The main relay breaks the high voltage circuit during an accident or if something is wrong with the circuit during braking (ignition off).

Pre-Charge Relay

Inrush current flows to a condenser for charging; therefore a pre-charge relay, with pre-charge resistance is required to receive the inrush current and reduce the load on the main relay.

EV RELAY DESIGN CONSIDERATIONS

SELECTING THE RIGHT EV RELAY

When the pre-charge relay (r1) is closed, the inrush current charges the capacitor via resistor (r2) reducing the load on the main relay. The main relays also break the high voltage circuit during breaking (ignition off) or short circuit situations.

When choosing pre-charge and main charge relays, the engineer needs to consider the following design parameters:

- A. Battery Voltage: V_B
- B. Pre-Charge Resistor: R
- C. Capacitance: C_F
- D. Battery Internal Resistance: r_2
- E. Wire Harness Resistance: r_1
- F. Pre-Charge Timing

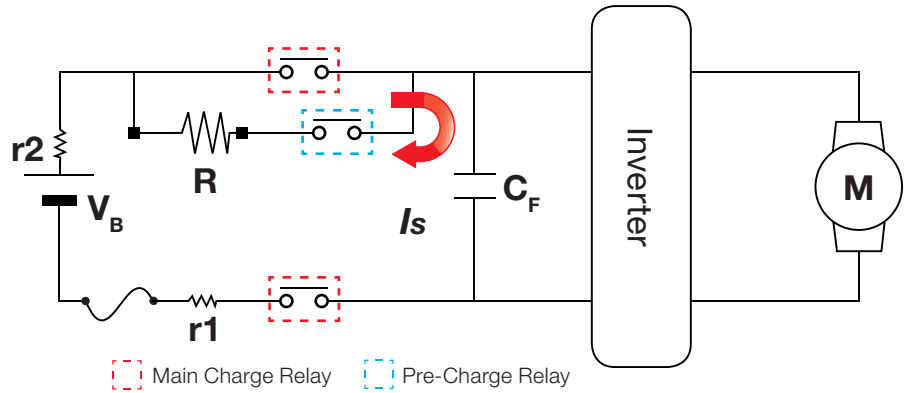

INRUSH CURRENT FLOWING THROUGH RELAYS

V_B (V)	400
R (ohm)	12
C (F)	0.001
Internal Batt. r1 (ohm)	0.150
Wire r2 (ohm)	0.007
Pre-Charge Time, t (s)	0.10

$$V_C = V_B \cdot e^{\left(\frac{-t}{RC}\right)}$$

$$I = \frac{V_B}{R} \cdot e^{\left(\frac{-t}{RC}\right)}$$

$$I_{0.1} = \frac{V_B - V_C}{(r_1 + r_2)} \cdot e^{\left(\frac{-t}{C(r_1 + r_2)}\right)}$$

t (s)	V_B (V)	I (A)
0.000	0.0	33.3
0.010	226.2	14.5
0.020	324.4	6.3
0.030	367.2	2.7
0.040	385.7	1.2
0.050	393.8	0.5
0.060	397.3	0.2
0.070	398.8	0.1
0.080	399.5	0.0
0.090	399.8	0.0
0.100	399.9	0.6
0.110	400.0	0.0
0.120	400.0	0.0
0.130	400.0	0.0
0.140	400.0	0.0
0.150	400.0	0.0
0.160	400.0	0.0
0.170	400.0	0.0
0.180	400.0	0.0

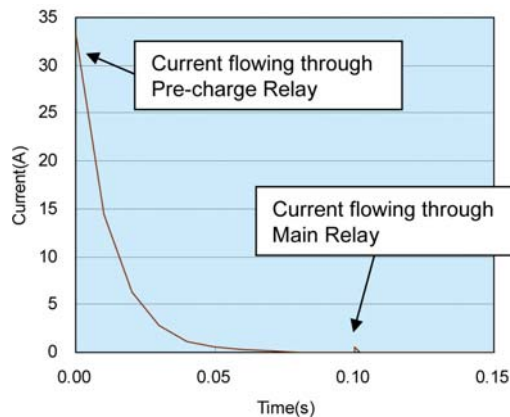

Simulated Data

EV RELAY DESIGN CONSIDERATIONS

CURRENT PROFILE CONSIDERATIONS

The vehicle's actual current profile is another important parameter to consider. Below is a graphical depiction of a vehicle's charging and discharging current swings. The current swing can peak in the hundreds of Amps. However, peak levels should not be the determining factor when selecting relays. There are other factors to consider as a whole: wire resistance, temperature and most importantly, AVERAGE (RMS) current levels.

Below are two examples of a hybrid vehicle's current profile. The current is measured between battery charge/discharge during full acceleration. In case one, the AVERAGE current drawn over time is approximately 62A, whereas in case two the AVERAGE current drawn is 55 A. In both cases Panasonic's 80A EV Relay is recommended.

Case 1

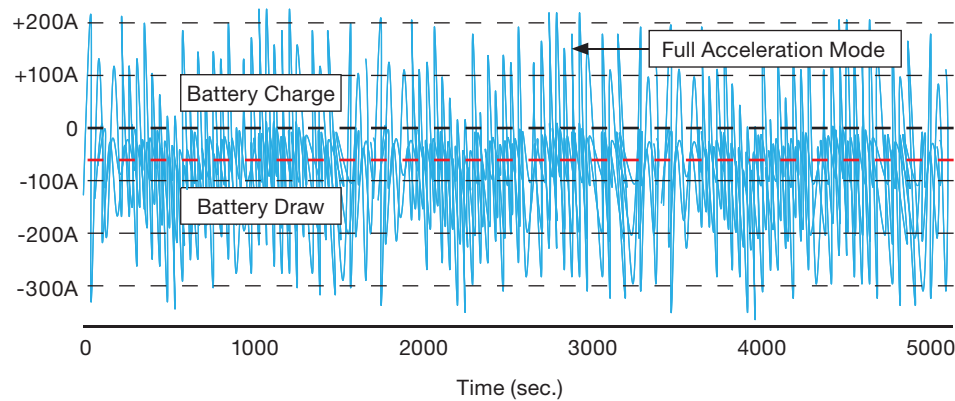

Case 2

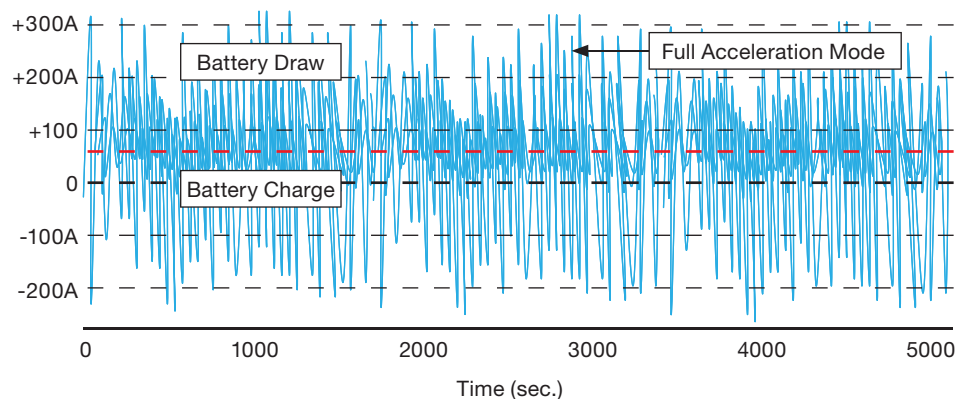

Note:

Actual current profile measurements are important. It is critical to share this data with the Panasonic technical team in order to recommend the best performing Relays.

PHOTOMOS RELAY

Semiconductor MOSFETs are used in certain automotive designs, such as battery cell monitoring and capacitor charging/discharging. Panasonic PhotoMOS® relays are an excellent alternative for those designs.

The internal construction of an automotive grade PhotoMOS has added features, like double molding, which make it more rugged and durable for everyday harsh environments.

Selecting the proper PhotoMOS relay depends on its derated voltage. Derating is essential in any reliable design and is an important factor when considering product life. The chart below depicts the absolute maximum ratings for select PhotoMOS part numbers.

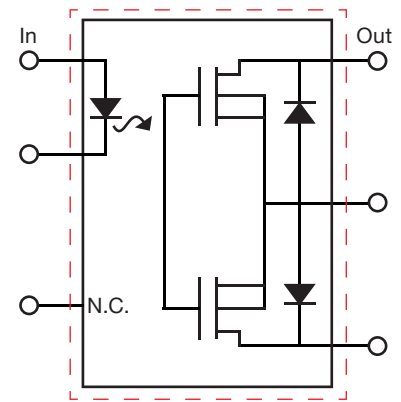

PhotoMOS Internal Construction

AQV258HAX***

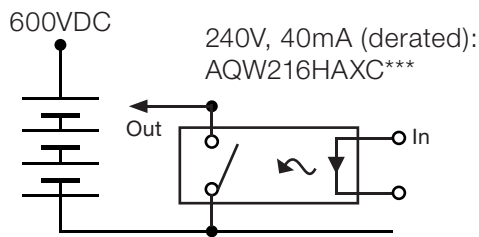

Part Number	Type	Package	Contact Configuration	Absolute Maximum Rating			
				Load Voltage	Load Current	Temperature Limit	
						Operating	Storage
AQW216HAX***	GU	DIP 8 Pin (SMD)	2 Form A	600V	40mA (50mA; 1A)	-40 ~ 85°C	-40 ~ 100°C
AQW212HAX***	GU	DIP 8 Pin (SMD)	2 Form A	60V	500mA (600mA; 1A)		
AQV258HAX***	HE	DIP 6 Pin (SMD)	1 Form A	1500V	20mA	-40 ~ 85°C	-40 ~ 85°C

LEAK DETECTION

A PhotoMOS relay can be used as a switch for electrical leak detection from the battery.

A car battery is electrically floating in reference to a car's chassis. Electrical leakage from the battery is checked when the PhotoMOS relay turns on.

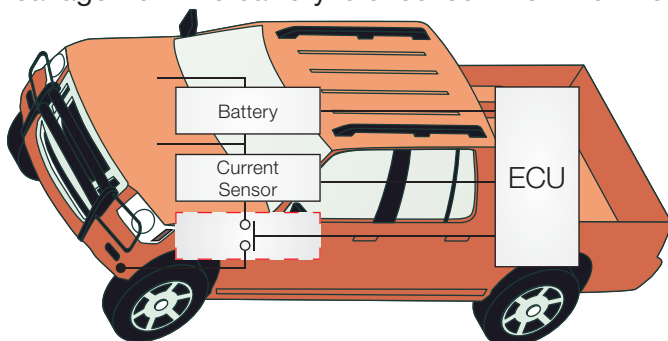

AQV258HAX C**

The battery's high voltage (1500V) requires the use of a PhotoMOS relay.



Note:

Please contact your local panasonic technical sales representative to help select the complete P/N based on your specific design requirements.

PHOTOMOS RELAY: BATTERY MANAGEMENT

High power Lithium-Ion and NiMH battery cells are vulnerable to abuse and need an electronic management system to provide constant level of charge to ensure longer battery life.

Battery management systems for the automotive industry are more demanding than typical battery monitoring systems. This is because the system has to interface with a large number of on board systems and must be able to change charging and discharging conditions rapidly.

A BMS monitors the conditions of each battery cell and tries to maintain the cells within their operating limits. It provides a failsafe mechanism in case of uncontrolled conditions and sets the battery to allow regenerative braking charges without overcharging the battery.

Panasonic automotive grade relays, PhotMOS AQV and AQW series, are ideal for scanning each and every battery cell where high switching speeds are required, while also providing excellent electrical isolation.

Automotive grade PhotoMOS relays are structurally different than standard PhotoMOS relays, as they are double-molded internally in order to accommodate the high mechanical stress present in a typical automotive environment.

Designers should be aware of the difference between automotive and non-automotive grade PhotoMOS relays when choosing the correct relay for their vehicle applications.

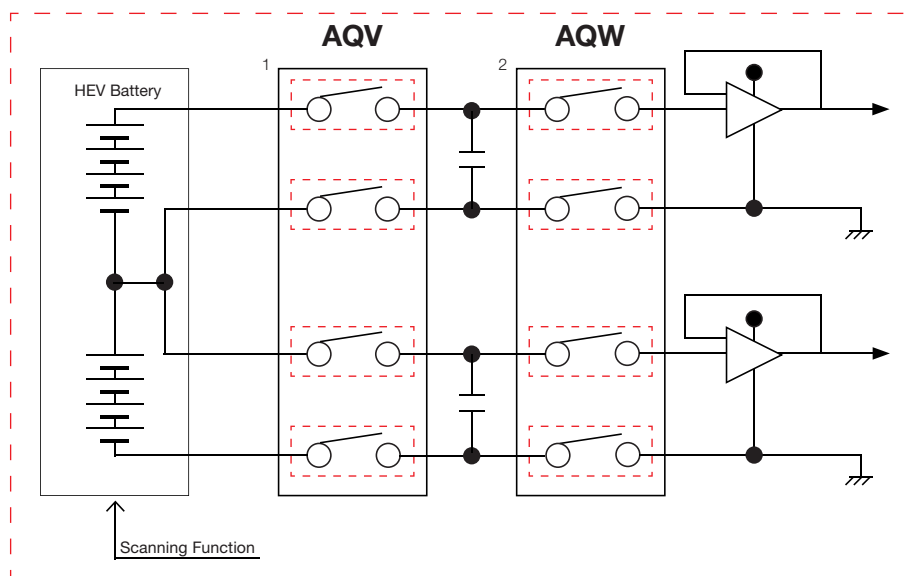
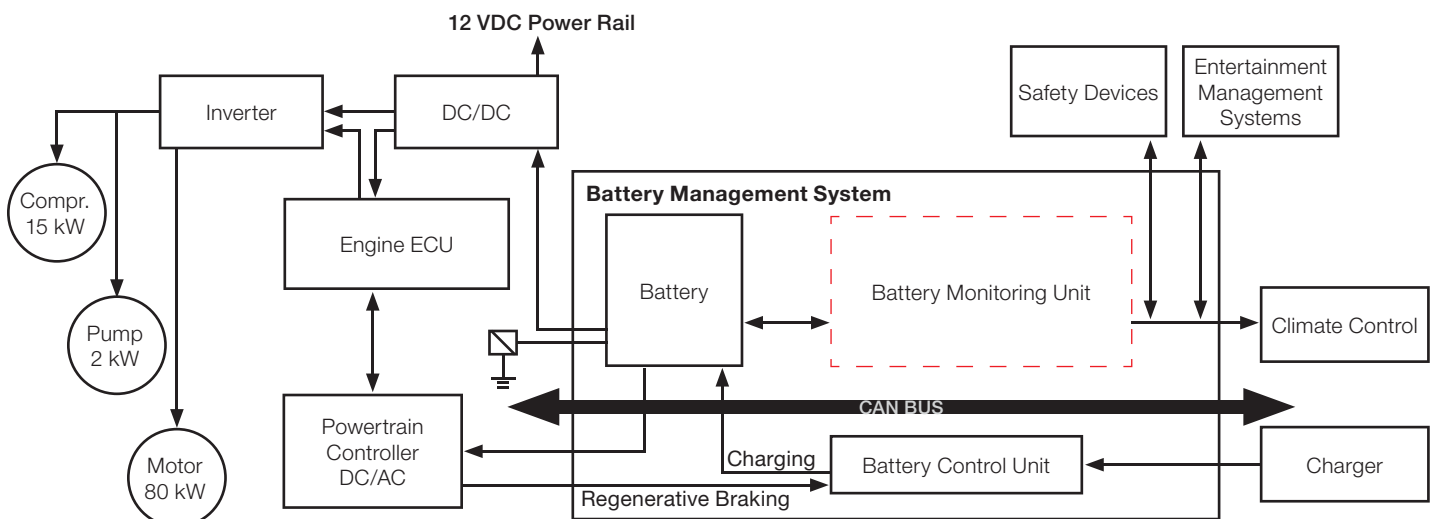
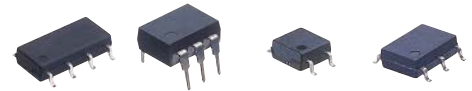

PHOTOMOS RELAY: BATTERY LEAKAGE/BALANCE

BATTERY LEAKAGE DETECTION

PhotoMOS relays are used as a high speed “electronic switch” to detect current leakage from batteries. A battery is electrically floating above ground. To check for battery leakage a PhotoMOS relay is turned on.

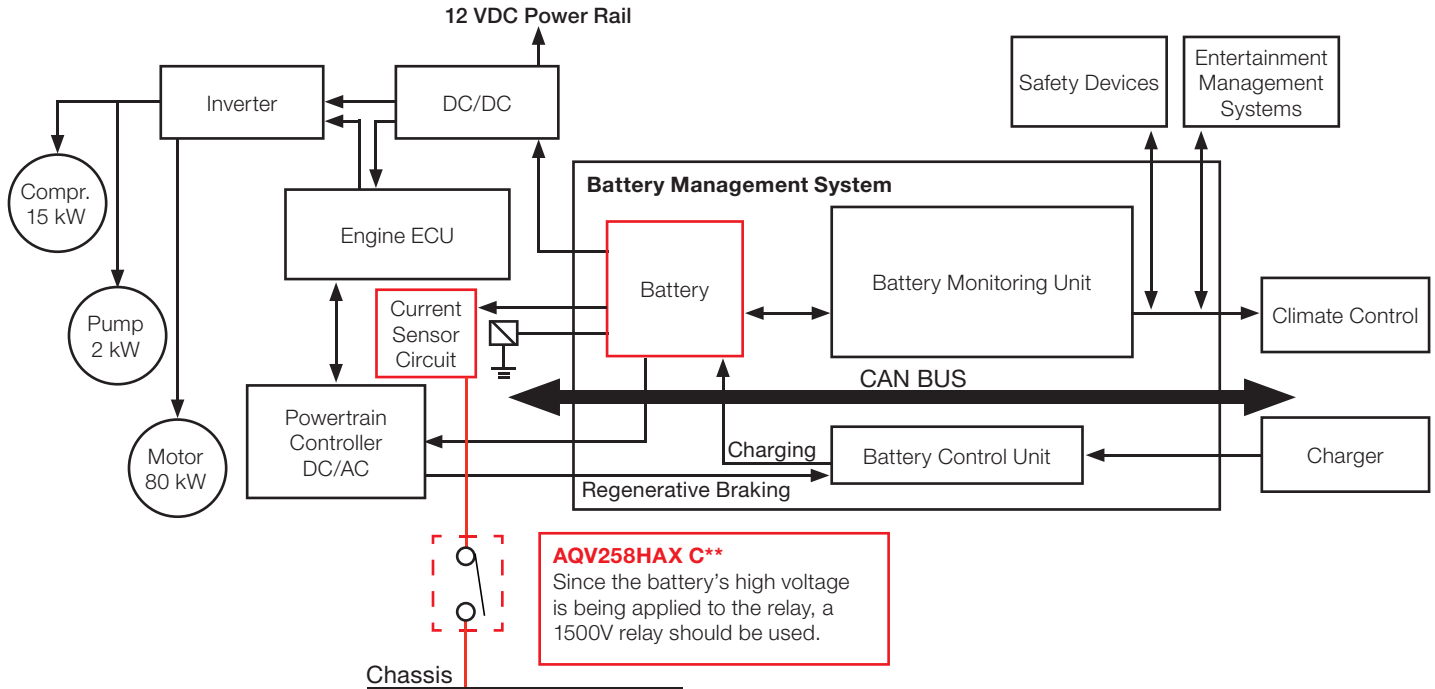

BATTERY CELL VOLTAGE BALANCING

PhotoMOS relays are also used as a “switch” to help balance cell voltages in Li-ion batteries.

It is critical to maintain similar or equal charge levels between cells to prevent the cells from being damaged, which would negatively affect overall battery life.

To prevent this, PhotoMOS can be used to help maintain equal charge levels for each cell.

AQW212HAX C**
PhotoMOS (R type) are used to minimize current losses during voltage balancing.

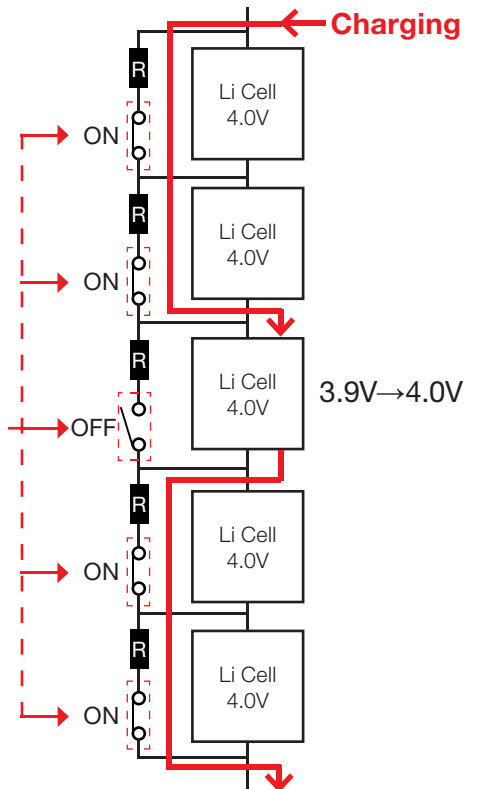

Note:
Please contact your local panasonic technical sales representative to help select the complete P/N based on your specific design requirements.

PHOTOMOS: BATTERY CHARGING/DISCHARGING

When solid state PhotoMOS relays are open, the capacitors are electrically “floating” above ground.



CHARGING

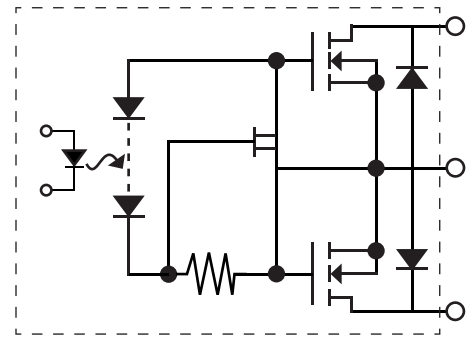
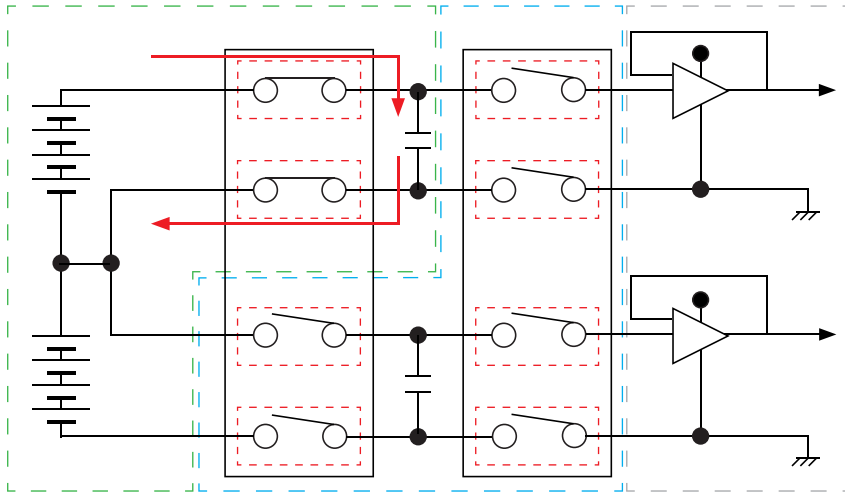

PhotoMOS Internal Construction

MEASURING

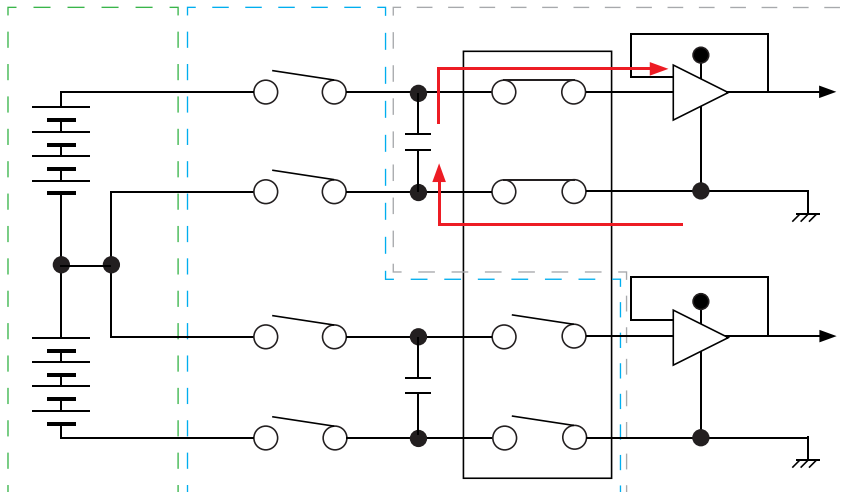

RECOMMENDED P/Ns

AQW216HAX C**

The I/Os of PhotoMOS relays are insulated, the low and high voltage sides are safely separated, this protects sensitive ICs like CPUs and Memory.



AQV258HAX C**

When measuring battery cells a 1500V relay should be used.



Note:

Please contact your local panasonic technical sales representative to help select the complete P/N based on your specific design requirements.

STOP IDLE SYSTEMS

Government regulations require that truck drivers rest at least 10 hours for every 14 hours of driving. During this resting period, or while waiting at a border-crossing or during loading/unloading, truck drivers usually “idle” their engines to operate A/C, appliances or entertainment devices. An idling truck burns considerable amounts of diesel fuel, wasting energy, producing carbon dioxide and causing unnecessary engine deterioration.

To alleviate the negative side effects of idling; auxiliary heating, cooling, and/or complete auxiliary power unit (APU) systems are available. In addition, off/on-board electrical supply systems are now available through an inverter/charger to the alternator and battery bank. Furthermore, outlets for appliances and advanced truck operating systems have electromechanical relays playing an important role in power management. There are at least 20 manufacturers in the United States and Canada.

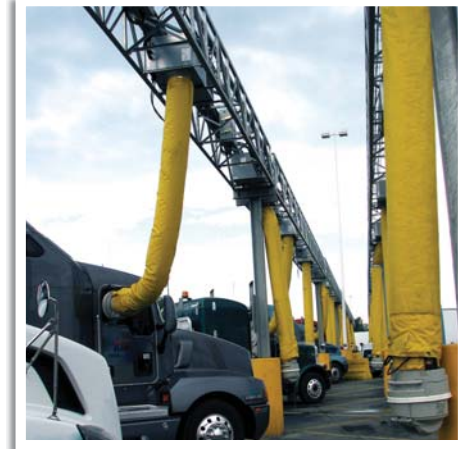

ENERGY LOSS

Source: US Dept. of Energy

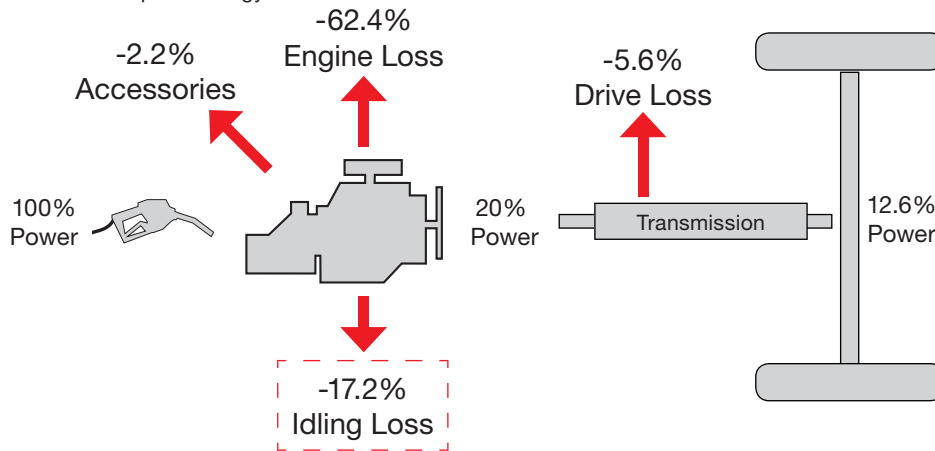

Stop Idle System Usage:

- A/C compressor: Up to 4 kW
- Appliances: Up to 2 kW
- Battery Charging: 0.5 - 3kW
- Block Heater: 1.0kW -2.5kW
- Blowers & Lights: 0 - 1 kW
- Electric Heat: Up to 3kW
- Fans: 0.2 kW
- Fuel Heater: 1.0 kW
- HVAC: 1.2 – 4.4 kW
- Interior Electronics: 0.2 kW
- Microwave: 1.0 kW
- Oil Pan Heater: 0.15kW-0.3kW
- Refrigerator: 140kW
- Television: 0.75 kW
- VCR or DVD: 0.75 kW

CIRCUIT EXAMPLE

A relay is used for current activation and/or current interruption in a 12/24VDC stop idle circuit, the starter is switched by an electronic control system.

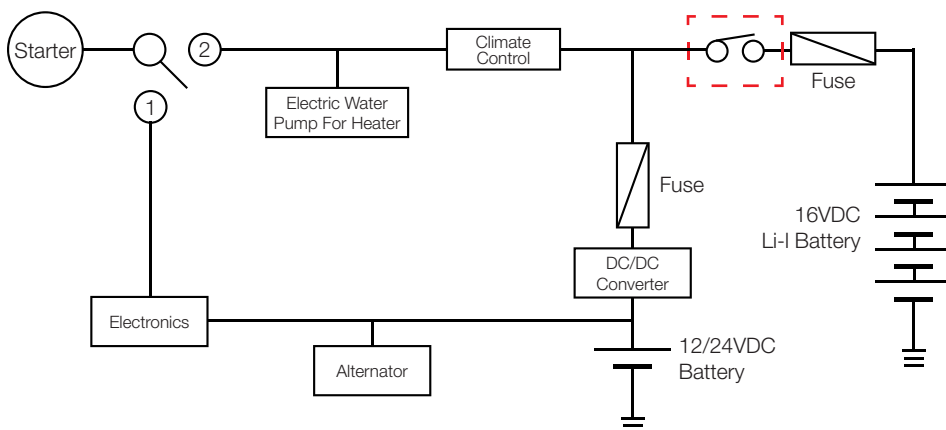

- Initial Start = starter SW/side 1 = by 12/24V battery
- Next Stage = starter SW/side 2 = by Li-I battery

APPLICATIONS

EV CHARGING STATION

PHEVs & EVs must be able to charge anywhere and anytime. Charging stations are being built throughout the country in homes, office buildings, shopping centers and public parking.

Vehicles will be connected to a 3-phase, 32A, 400V charging station generating close to 22 kW of power. This will require electric vehicles to be able to provide proper switching capabilities once the vehicle is connected. The electrical network transmits current at 60Hz AC at various nominal voltages (rms). PHEV batteries are DC devices that operate at a varying voltages depending on the state of charge (SOC) and charge/discharge rates.

Therefore, charging stations must provide both rectification and supply regulation. With rectification, AC current is converted to DC. Supply voltage regulation changes the charging rate based on the battery's charging characteristics.

The table at right depicts three basic charging options.

	Level 1	Level 2	Level 3*
Voltage	110-120 VAC	220 - 240 VAC	440 VAC
Phase	Single	Single	-
Current	16 A	30 - 80 A	-
Charge Time	8-16 Hrs.	4-6 Hrs.	30 Min.
Use	Residential	Business	Public

* In Development

CIRCUIT EXAMPLE

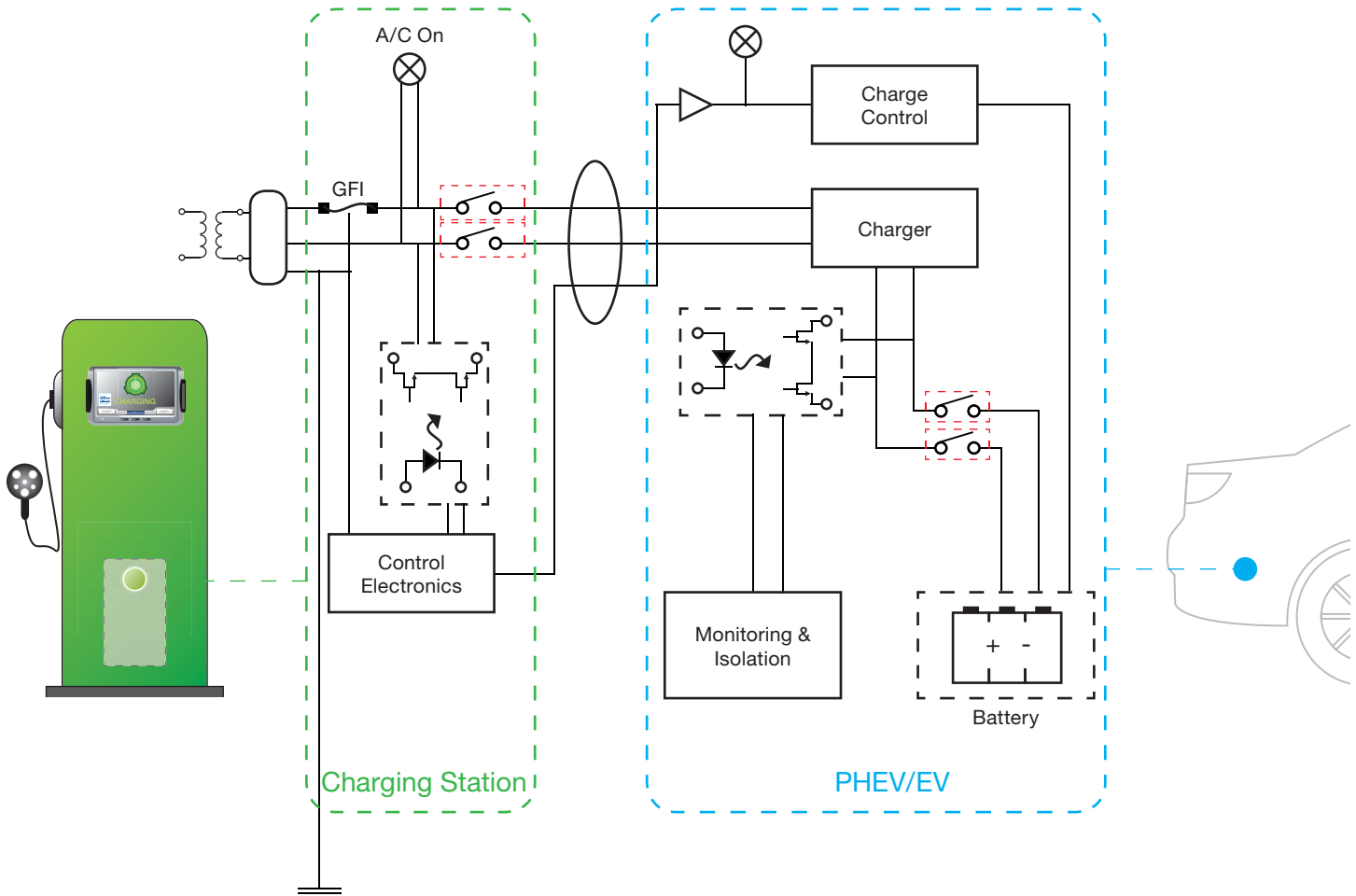

APPLICATIONS

DOOR LOCKS

Door lock circuits can use one CT or CJ relay. A single relay may also be used for the driver side lock.

4 Doors: One Twin Relay

2 Doors: One Relay

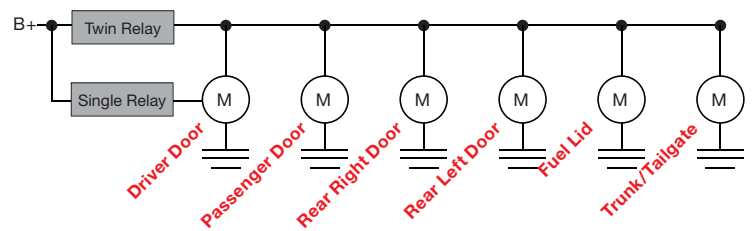

Motor Rotation: FWD (All Lock)

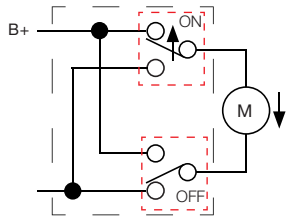

Contact 1 Turns On

Motor Rotation: REV (All Unlock)

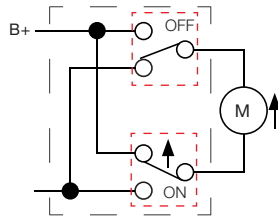

Contact 2 Turns On

Driver Unlock: Driver Door Only

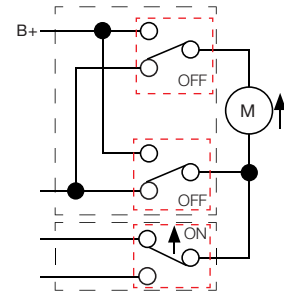

Single Relay Turns On

LOAD CURRENT (All Motors)

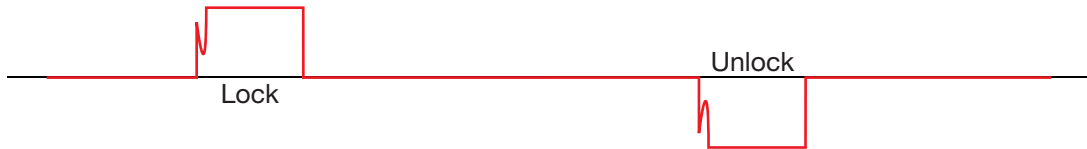

POWER WINDOWS

Typical power window circuits use one twin relay per window.

4 Doors: Four Twin Relays

2 Doors: Two Relays

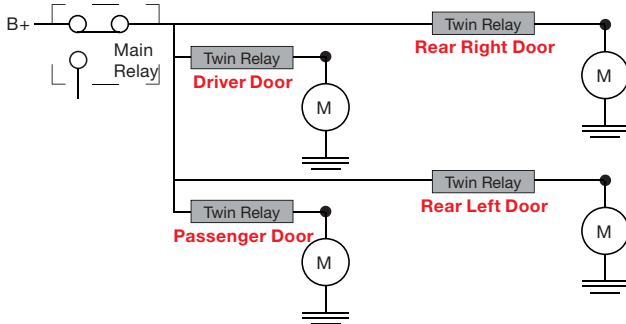

LOAD CURRENT (One Motor)

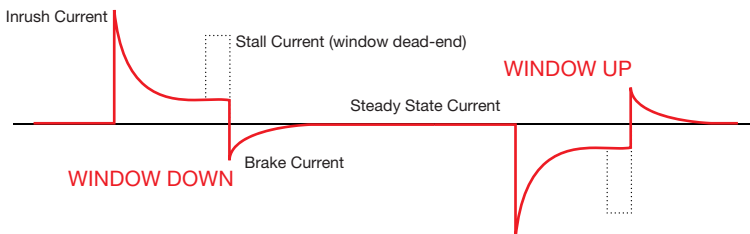

H Bridge twin relays are used to control the FWD and REV rotation of the motor.

FWD Motor Rotation: Window Down

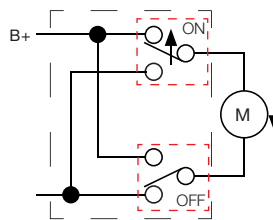

Contact 1 Turns On

Motor Stop: Window Stop

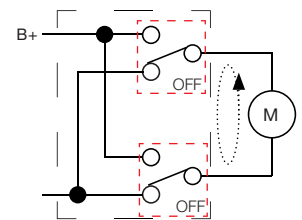

Contact 1 Turns Off

REV Motor Rotation: Window Up

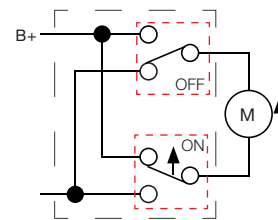

Contact 2 Turns On

WIPERS

Typical windshield wiper circuits use two single relays. One relay is used for wiper ON and another relay is used for wiper speed.

Wiper On

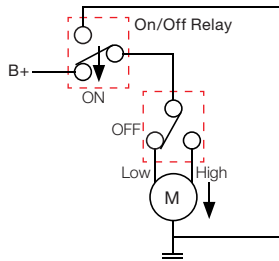

Wiper Off

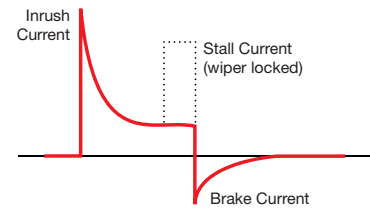
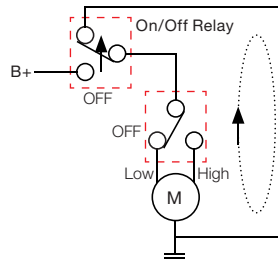

Wiper Low

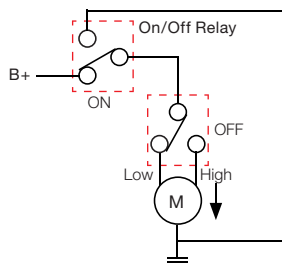

Wiper High

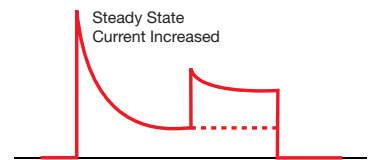
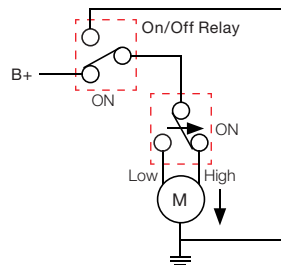

WASHER FLUID PUMPS

Panasonic offers a wide variety of small, high quality relays for windshield washer fluid pumps.

- CT1,5 (Slim)
- CJ1,5 (Slim & Small)
- CP (Low Profile)
- CQ (Silent)

Circuit Example

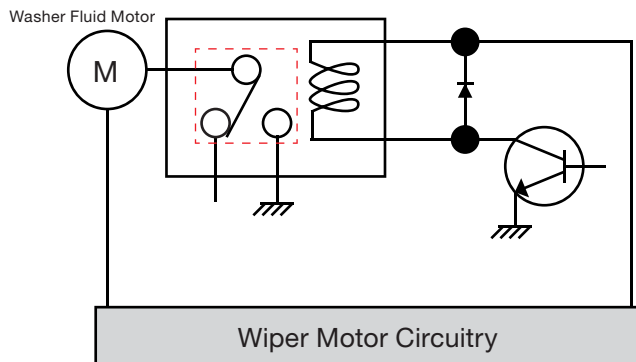

Current Example

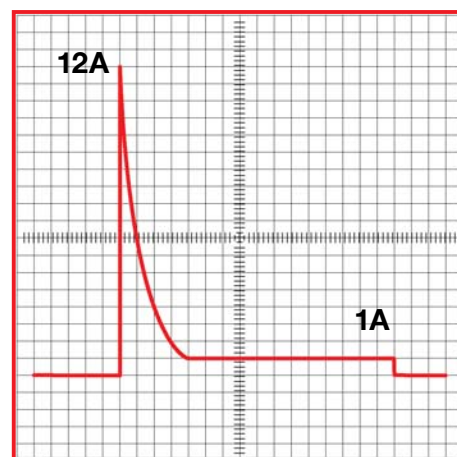

Inrush Current: 12A | Steady Current: 1A | ON/OFF: 1s/6s | 50K Cycles

ELECTRIC POWER STEERING (EPS)

Panasonic offers the CB/CM relays as the perfect solution for the power and motor lines in the circuitry comprising Electric Power Steering circuits. In addition, depending on the specification and requirements of the design, Panasonic offers smaller relays like the CN-H, CN-M and CP relays.

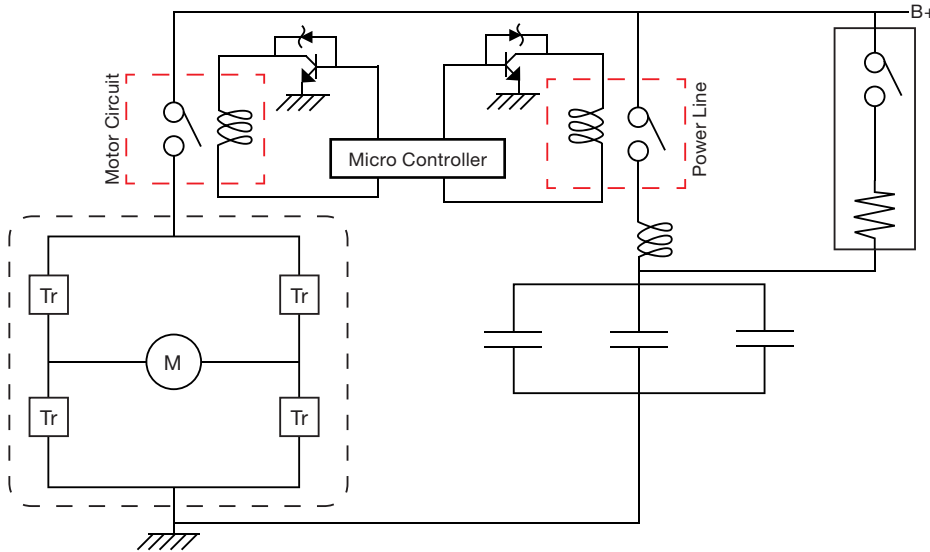

EPS: 3 PHASE MOTORS

CB/CM/CN-H Relays (1a x 2pcs)

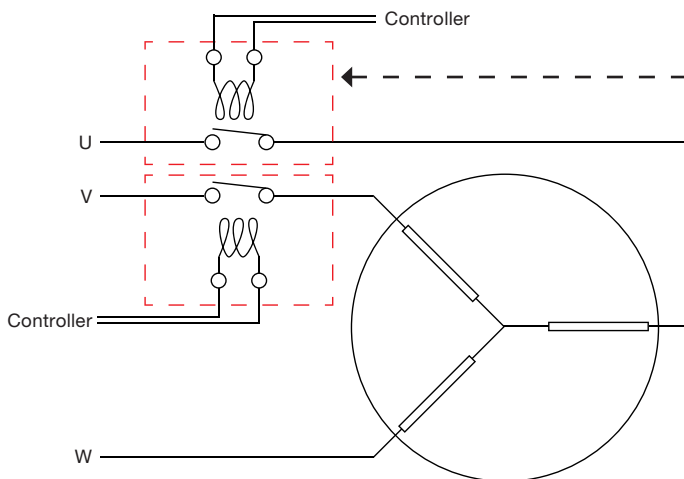

CW Relay (2 form A)

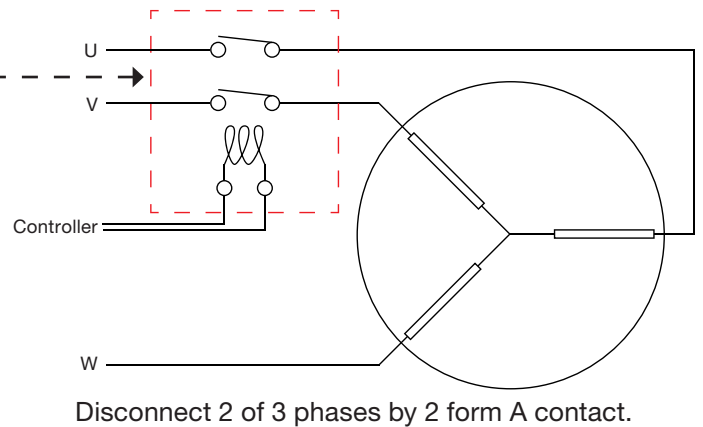

ANTI-LOCK BRAKING SYSTEMS

Panasonic's tilt sensors are used in anti-lock braking systems to detect braking acceleration and timing in order to prevent the car's wheels from locking.

ROAD TILT DETECTION

In an effort to increase fuel efficiency while stopped, a car's transmission can automatically be changed from drive (D) to neutral (N) to save fuel. However, this operation can only be performed when the car is on a flat surface to prevent the car from rolling.

SPECIALTY VEHICLES

- Commercial Transportation
- Basket Crane (Cherry Picker)
- Tractor
- Electric Wheelchairs
- Scooters
- Wheelchair Lift
- Stair Lift
- Excessive Vehicle Tilt
- Excessive Vibration

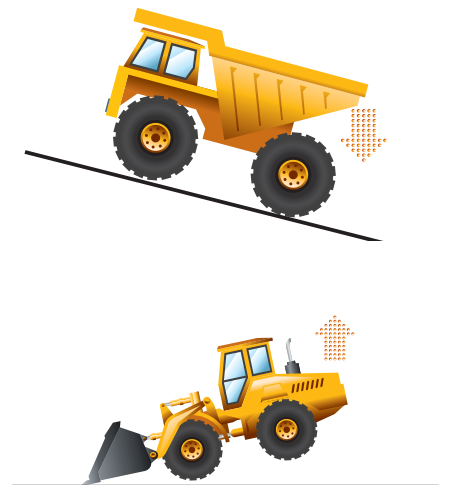
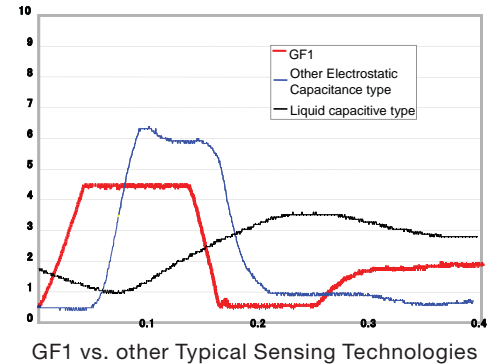

VEHICLE TILT SENSORS

- Single-Axis Acceleration Sensor
- Detection Accuracy: $\pm 0.5^\circ$
- Analog Output: 0.5 to 4.5V
- Enclosure: IP67
- Temperature Range: $-30 \sim 85^\circ\text{C}$
- Easy to Connect



AGF10711 ($\pm 30^\circ$)
W/O Bracket



AGF11311 ($\pm 90^\circ$)
W/ Bracket

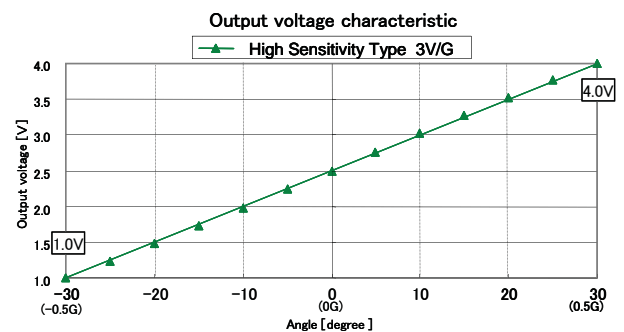
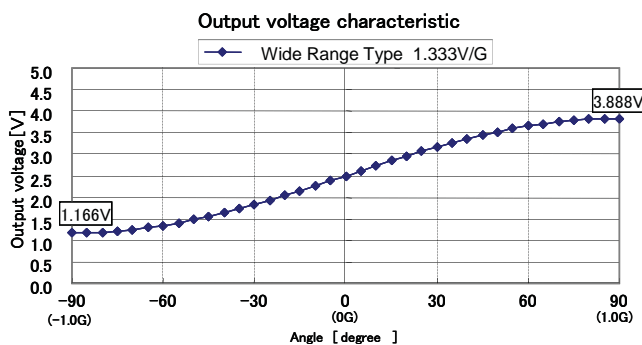





AUTOMOTIVE RELAY OVERVIEW



		PC Board													Plug-In	H.V.	MOSFET
Feature	Twin		Single								SMD		Mini ISO	Micro ISO	-	-	
Contact Arrangement	1c x 2	1c x 2	1a	1a, 1c	1a, 1c	Double Make Contacts	1c	1c	1a, 1c	1a, 1c	1a, 1c	1a, 1c	1a, 1c	1a, 1c	1a	-	
	CT/CT-P	CJ	CN-H	CN-M	JJ-M	JJ-M *	CT/CT-P	CJ	CP-P	CP	CP	CN-M	CB	CM	EV	P-MOS	
SAFETY	Headlights		●	●								●	●	●			
	Tail Lights		●	●	●		●					●	●	●			
	Fog Lights			●	●							●	●	●			
	Signal Lights					●											
	Windshield Wipers					●			●	●	●						
	Power Mirrors	●	●			●		●	●	●	●						
	Windshield Washer						●		●	●	●						
	Defroster			●	●				●	●	●	●	●	●	●		
	Horn	●				●		●	●	●	●						
COMFORT	Power Sunroof	●	●			●			●	●	●						
	Power Seats	●	●			●	●	●	●	●	●						
	Lift Gate/Hatchback	●	●			●			●	●	●						
	Power Window		●			●			●	●	●						
	Keyless Entry						●										
	Door Lock	●	●			●		●	●	●	●	●					
	Slide Doors	●	●			●		●	●	●	●	●					
	Security						●										
	Seat Heater			●	●				●	●	●	●		●			
	Audio					●		●	●	●	●						
	Temp Control					●											
	Auto Antenna	●	●			●		●	●	●	●	●					
	Cruise Control					●		●	●	●	●	●					
POWERTRAIN	Heater System		●	●								●	●	●			
	Radiator Fan Motor		●	●								●	●	●			
	Engine Starter Motor		●	●								●	●	●			
	EPS		●										●	●			
	Magnetic Clutch												●	●			
	Traction Control					●		●	●	●			●	●			
	Adaptive Suspension					●		●	●	●							
EV	EV/HEV/PHEV														●	●	
	Other Vehicles														●	●	
	BMS, etc														●	●	

RELAY SPECIFICATIONS

HEV





	SEV60A Horizontal *	SEV60A Vertical *	SEV80A Horizontal *	SEV80A Vertical
Part Number	AEVS16012**		AEV18012	
Mount	Screw Mount			
				
Dimensions (mm)	77 x 67.8 x 37.7	76 x 36 x 72.3	86.5 x 74.5 x 40.5	75.5 x 79 x 40
Carry Current (A) (@ 85°C)	60		80	
Max Cut-Off Current	600A 300VDC, 5 Cycles		800A 300VDC, 1 Cycle 700A 300VDC, 5 Cycles	
Life Cycles w/ Resistive Load	60A 400V 1,000 Cycles		80A 400V 1,000 Cycles	
Coil Consumption (W)	5.0		4.5	





EV & PHEV

	EV120A	EV300A
Part Number	AEV14012	AEV19012
Mount	Screw Mount	
		
Dimensions (mm)	75.5 x 40 x 80	111 x 63 x 74.7
Carry Current (@ 85°C)	120A 400VDC	300A 400VDC
Max Cut-Off Current	1,200A 300VDC, 1 Cycle	2,500 A 300VDC, 10 Cycles
Life Cycles w/ Resistive Load	30A 400VDC, 3,000 Cycles	300 A 400V, 1,000 Cycles
Coil Consumption (W)	4.2	37.9 (inrush approx. 0.1 sec.) 3.6 (stable)





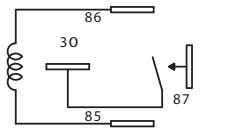
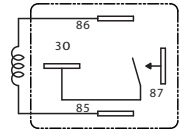
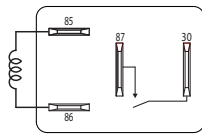
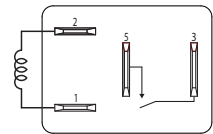

* Please contact your local Panasonic sales representative for product availability information and any special design considerations.

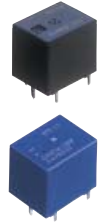

RELAY SPECIFICATIONS

	CT-P2 / CT-P5	CT2 / CT5	CJ2 / CJ5	CR
				
Contact Arrangement	1c x 2			
Load	30A, 14VDC	20A, 14VDC	20A, 14VDC	20A, 14VDC
Coil Consumption (mW)	1000	800	640/800	640
Dimensions (mm)	17.4 x 14 x 13.5	17.4 x 14 x 13.5	13.7 x 12.2 x 13.5	24.6 x 12 x 18.5
Weight (g)	8	8	6.5	12.5
Noise (dB)	55	55	65	45
Features	<ul style="list-style-type: none"> • High Current • H-Bridge • 10 Terminals 	<ul style="list-style-type: none"> • H-Bridge • 8 Terminals (CT2) • 10 Terminals (CT5) 	<ul style="list-style-type: none"> • Compact • H-Bridge 	<ul style="list-style-type: none"> • Quiet

	CB - Mini ISO		CM - Micro ISO	CV - Flat, Micro ISO
				
Contact Arrangement	1a, 1c	1a	1a, 1c	1a, 1c
Max. Switching Load	N/O: 40A 14VDC N/C: 30A 14VDC	N/O: 70A 14VDC	N/O: 35A 14VDC N/C: 20A 14VDC	N/O: 20A 14VDC N/C: 10A 14VDC
Max. Carry Current (A)	35	45	20	20
Coil Consumption (W)	1.4	1.8	1.5	0.8
Dimensions (mm)	26 x 22 x 25	26.5 x 22 x 25.5	20 x 15 x 22	22.5 x 15 x 15.7
Weight (g)	33	33	20	15
Noise (dB)	70		70	60
Features	High Current		Compact	Flat
Schematic				
Notes	PCB and 24V Style Available			PCB Style Available

RELAY SPECIFICATIONS

	CN-H	CN-M	CY	JJM JJM2W *	CP CP-P *	CT1 / CTP1*	CJ1	CQ
Through Hole								
Contact Arrangement	1a	1a, 1c	1a, 1c	1a, 1c	1a, 1c	1c	1c	1c
Switching Current	30A 14VDC	30A 14VDC	30A 14VDC	20A 2x6A* 14VDC	20A 14VDC	20A / 30A* 14VDC	20A 14VDC	20A 14VDC
Coil Consumption (mW)	450 650	640	450 640	640	450 640*	800 / 1000*	640 800	640
Carry Current (1hr/85°C)	30 A 25 A	25 A	25 A 20 A	20A 2x4A*	25 A 30 A*	20 A / 20 A*	20 A	20 A
Dimensions (mm)	17 x10.6x18.3	15.5x11x14.4	22x16x16	15.5x12x13.9	14x13x9.5	17.4x7.2x13.5	12.2x7.2x13.5	17x13x16.6
Weight (g)	9	5.5	12	5	4	4	3.5	6.5
Noise (dB)	65	60	65	65	60	55	60	45
Features	High Current	Small, High Current	High Current	* Double Make	Flat * 35A	Slim	Compact	Quiet

	CN-M	CP CP-P
Surface Mount		
Contact Arrangement	1a, 1c	1a, 1c
Load	30A 14VDC	20A 14VDC
Coil Consumption (mW)	640	450 640
Dimensions (mm)	15.5 x 11 x 15.1	14 x 13 x 10.5
Weight (g)	5.5	4
Noise (dB)	60	60
Features	High Current Small	Flat

Panasonic has a long history of supplying high quality products in the transportation industry.

QUALITY CONTROL

Panasonic Electric Works Automation Components Division is ISO/TS16949 accredited. This accreditation covers our quality management system for our entire spectrum of automotive products, from mechanical to semiconductor relays.

ISO/TS16949 is a quality management standard based on QS9000 which is used by the "Big 3" American automobile manufacturers. This quality management system standard also incorporates requirements set by the European automobile industries. It calls for a comprehensive quality management system that includes CS, cost performance and ongoing improvement.

EV RELAYS

- Less Than 1 PPM Failure Rate (for more than 12 years in the automotive market)
- 7.2 Million EV Contactors Sold Since 1997
- Fully Automated Manufacturing Line
- Twenty years selling Main & Pre-Charge Relays

CERTIFICATION STATUS

- ISO14001 Certified
- ISO9001 Certified
- ISO/TS16949 Certified
- Panasonic Electric Works is a Registered Corporation in the European Automotive Industry's International Material Data System (IMDS).

CERTIFICATION PROCESSES

- APQP: Advanced Product Quality Planning & Control Plan
- DFMEA: Design Potential Failure Mode & Effects Analysis
- PFMEA: Process Potential Failure Mode & Effects Analysis
- PPAP: Production Part Approval Process
- CS: Customer Satisfaction

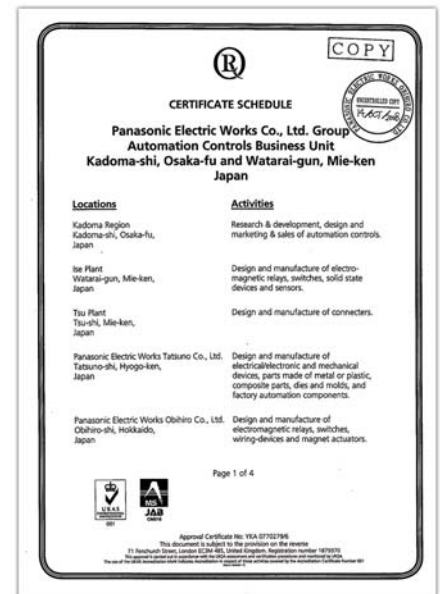

SEALED SWITCHES

Panasonic Electric Works' switches are primarily used to serve two functions in the transportation market space, detection and activation.

DETECTION

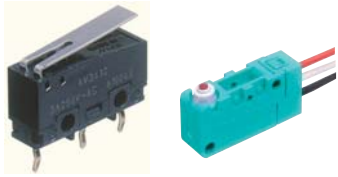

ACTIVATION



TURQUOISE SWITCH CONSTRUCTION (IP67)

Panasonic's ABJ, ABS and ABV turquoise switches are built with a high tolerance to extreme environmental conditions, meeting IP67 specifications.

Ultrasonic Swaging Process

The rubber cap is sealed securely to the switch cover during an ultrasonic swaging process.

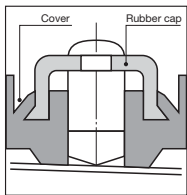
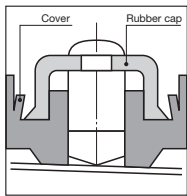

Ultrasonic swaging is a process that bends material using ultrasonic vibration

Body: IP67 Protective Grade
Dust and liquid Protected

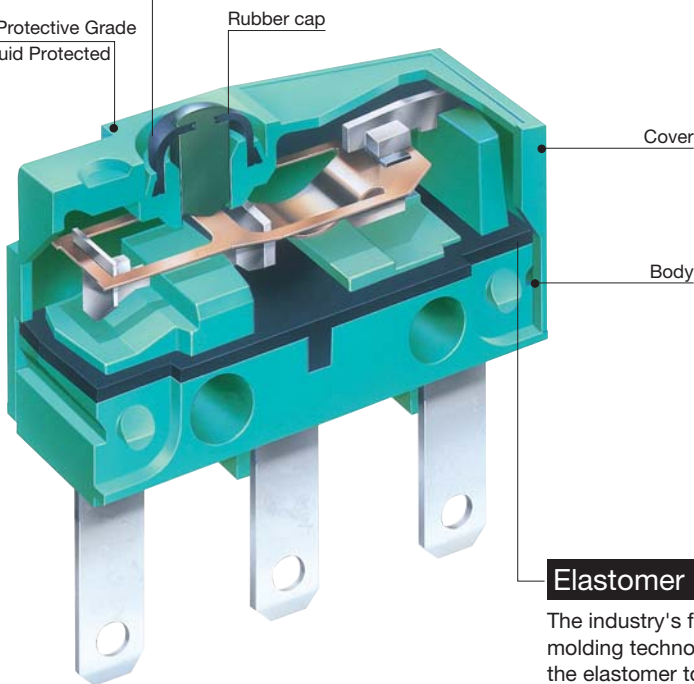

Elastomer Double Molding

The industry's first elastomer double molding technology is used to mold the elastomer to the switch body creating a reliable seal between the body and cover.

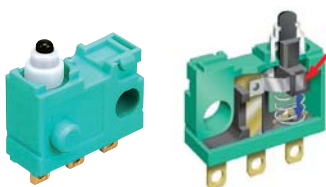

ASQ CONSTRUCTION (IP67)



- Clip Contact System Provides Excellent Contact Reliability
- Long Over Travel for Easy Design and Assembly
- Sliding Contact Structure for Silent Switching
- Meets IP67 Specifications

SEALED SWITCHES

RECOMMENDED SERIES

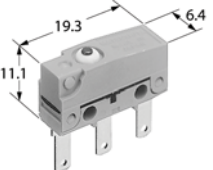
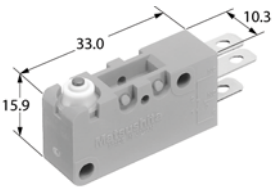
Series	Current Range	Dimensions
ASQ (Stroke)	1mA ~ 100mA Long Stroke Silent Switching	
ABJ	1mA ~ 2A	
ABS	1mA ~ 2A	
ABV	1mA ~ 5A	

APPLICATIONS

- Sunroof Position Detection
- Hatchback Open/Close Detection
- Interior Lamp Activation
- Fuel Tank Open/Close Detection
- Position Detection, Automatic Close & Lamp Activation for Sliding Doors
- Hood Open/Close Detection
- Warning Lamp Activation for Seat Belts, and Trunk Open/Close
- Key Rotation Detection
- Shift Lever Position Detection
- Key Detection
- High/Low Pressure Detection for Oil Systems
- Electromagnetic Valve Detection for Fuel Injection Control

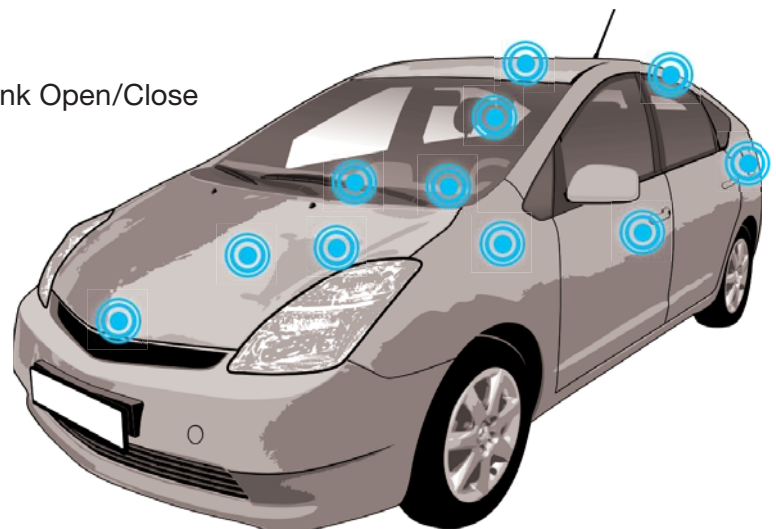

TOMORROW'S VEHICLE ELECTRIFICATION

Panasonic Electric Works is developing businesses to realize comfortable and eco-conscious lifestyles. Our aim is to contribute to the development of society and world culture by providing living spaces which satisfy both human needs and environmental considerations by drawing on and linking people's wisdom and knowledge. Panasonic has signaled a goal of becoming "the No. 1 Green Innovation Company in the electronics industry" by 2018, the 100th anniversary of Panasonic's foundation.

eco
ideas

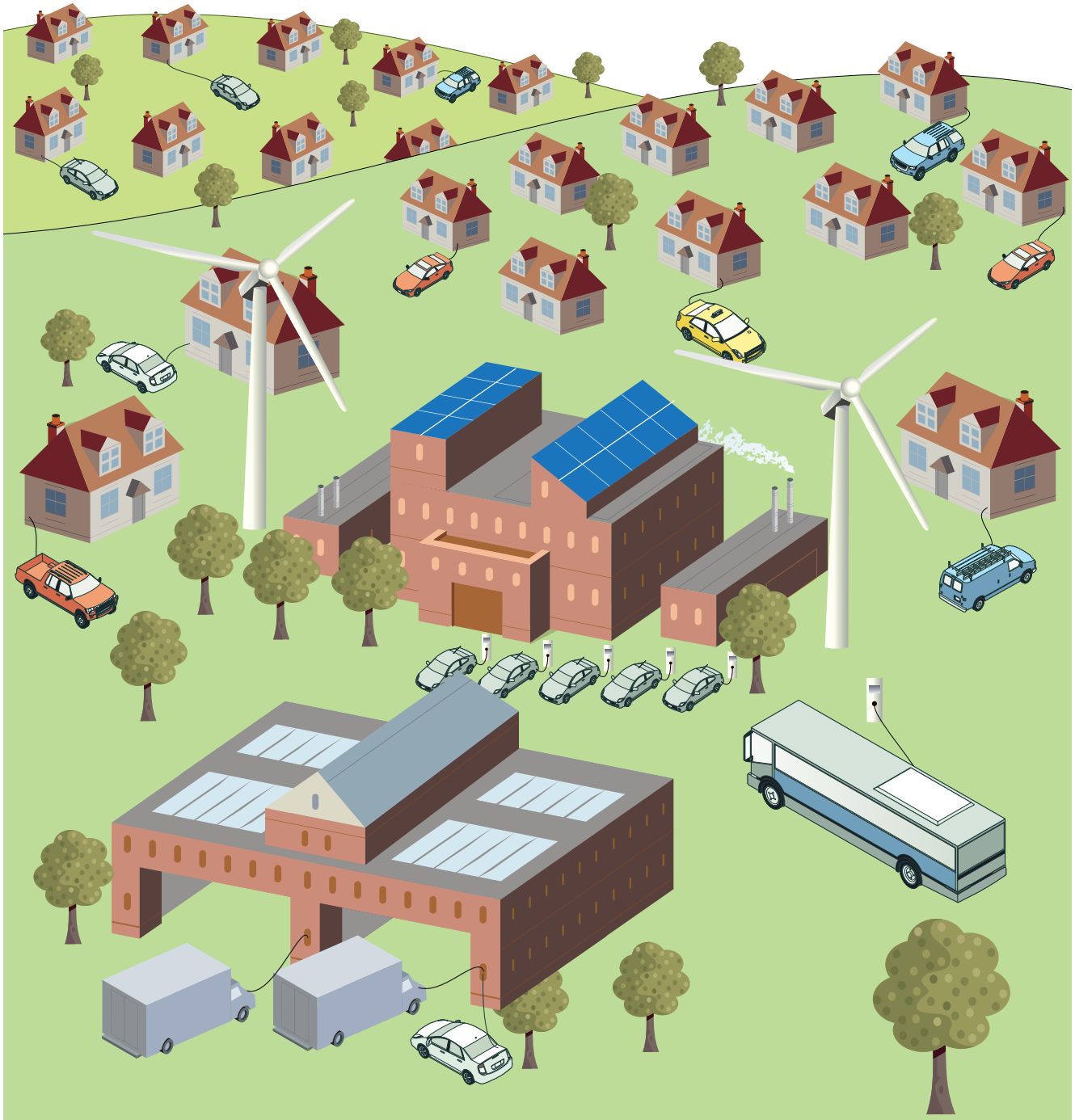

DESIGN CONSIDERATIONS

GENERAL APPLICATION

What is the end product: truck, car, bus, etc?

What is the application?

What type of load is the relay turning on and off (Resistive, Motor, etc)?

What is the RMS current? What is the peak current?

What is the inrush current? Duration of the inrush current?

How much voltage is being switched?

Is the relay “hot” or “cold, dry” switching in the application?

What is the switching frequency of the application? How many seconds/ hours is the relay on/off?

What is the ambient temperature where the relay will be operating?

What are the vibration and shock specifications required for the application?



EV SPECIFIC DESIGN CONSIDERATIONS

What is the battery type (lithium ion, nickel metal hydride, etc)?

What is the capacity of the battery in Ah?

What are the short circuit characteristics (peak/current profile)?

What is the rated current of the fuse?

What is the diameter of the wire harness, mm²?

What is the power rating on the motor?

What size capacitor is being used in the pre-charge circuit?

What is the maximum cut-off current?

EV RELAY SELECTION

Customer:

Program name:

Battery

Type:			
Max. Voltage:		V	
Capacity:		Ah	

Motor

Rated Power:		W	
--------------	--	---	--

Capacitor

Capacitance:		F	
--------------	--	---	--

Fuse

Rated Current:		A	
Part Number:			

Pre-charge Resistor

Resistance:		Ohm/W	
-------------	--	-------	--

Wire Harness

Size:		mm ²	
-------	--	-----------------	--

Connector

Brand Name:			
Part Number:			

Main Relay Control

Current Rating

Max. Carrying Current (Continuously):		A	
Short Term Current and Duration 1:		A and Sec	
Short Term Current and Duration 2:		A and Sec	
Short Term Current and Duration 3:		A and Sec	

Switching Rating

Electrical Life:		Cycles		VDC and A
Inrush Current:		A		VDC
Max. Cut-off Current:		A		times
Mechanical life:		Cycles		

Short Circuit

Max. Short-circuit Current:		A	
-----------------------------	--	---	--

Pre-charge Control

Pre-charge Time:		Sec		
Inrush Current:		A		VDC
Electrical Life:		Cycles		VDC and A
Mechanical Life:		Cycles		

EV RELAY SELECTION

10. Auxiliary or Sub-System Relay (Ex: charger)			
Max. Carrying Current (Continuously):		A	
Inrush Current:		A	VDC
Electrical Life:		Cycles	VDC and A
Mechanical Life:		Cycles	
11. Ambient Conditions			
Ambient Temperature Range:		degC	
Ambient Humidity:		%	
Corrosive Gas:			
Water or Oil Soaking:			
Vibration:		Hz at G	
Shock:		G	
External Magnetic Field:			
12. Main Relay			
Competitor Info:			
Brand Name:			
Part Number:			
Being Considered or Approved:			
Auxiliary Contacts Used? Why?			
Quantity Per:			
13. Pre-Charge Relay			
Competitor Info:			
Brand Name:			
Part Number:			
Being Considered or Approved:			
Auxiliary Contacts Used? Why?			
Quantity Per:			
14. Auxiliary or Sub-System Relay			
Competitor Info:			Sub-Systems (i.e. Heater):
Brand Name:			
Part Number:			
Being Considered or Approved:			
Auxiliary Contacts Used? Why?			
Quantity Per:			

 Required Field



Panasonic Electric Works of America

<http://pewa.panasonic.com>



629 Central Avenue New Providence, NJ 07974
1-800-276-6289
info@us.pewg.panasonic.com
<http://pewa.panasonic.com>

Design and specifications are subject to change without notice.
Please review technical specifications before purchase.
For any safety concerns regarding these products, please contact your Panasonic sales representative.



<http://www.twitter.com/panasonicelec>



<http://www.youtube.com/panasonicelec>

Panasonic ideas for life