

Power Factor Correction (PFC) Application Notes

Background

Every year, millions and millions of notebook computers, LCD monitors and LCD televisions are produced. With such a fast growing number of these and other electronic devices using more and more power, actions must be taken to ensure the functionality of the nationwide power grid.

In 2001, the European Union put EN61000-3-2 into effect to set the harmonic regulation standard on any power grid supplied application with power consumption over 75 watts. This essentially requires power factor correction (PFC). Additionally, a standby power dissipation limit is set to conserve power when a load is OFF.

“80 PLUS” is an initiative funded by electric utilities to integrate more energy efficient Power Supply Units (PSUs) - especially for desktop computers and servers. 80 PLUS certifies to more than 80% energy efficiency at 20%, 50% and 100% of rated load. To meet the 80 PLUS certification, PSUs require a PFC of 0.9 or greater at 100% load. This means PSUs that waste 20% or less electric energy (as heat at the specified load levels) will lead to reduced electricity consumption and lower bills. Rebates are sometimes given to manufacturers who use 80 PLUS certified PSUs.

Implementing power factor correction (PFC) into switch mode power supplies will maximize:

- The power handling capability of the power supply
- Current handling capacities of power distribution networks

Input power factor (PF) is defined as:

$$PF = \frac{\text{Real Power (watts)}}{\text{Apparent Power (VA)}}$$

PF is expressed as decimal number between zero and one (0 and 1). A non-corrected power supply with a typical PF equal to 0.65 will draw approximately 1.5 times greater input current than a PFC supply (PF = 0.99) for the same output loading. The non-corrected supply requires additional AC current to be generated which is not consumed by the load, creating I^2R losses in the power distribution network.

There are two types of PFCs:

1. Active
2. Passive

Passive PFC

The simplest form of PFC is passive (Passive PFC). A passive PFC uses a filter at the AC input to correct poor power factor. The passive PFC circuitry uses only passive components — an inductor and some capacitors (Figure. 1).

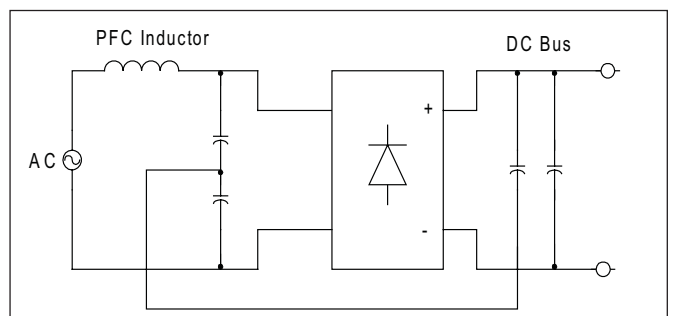

Figure 1: A passive PFC circuit requires only a few components to increase efficiency, but they are large due to operating at the line power frequency.

Although pleasantly simple and robust, a passive PFC rarely achieves low Total Harmonic Distortion (THD). Also, because the circuit operates at the low line power frequency of 50Hz or 60Hz, the passive elements are normally bulky and heavy.

Active PFC

Active PFC offers better THD and is significantly smaller and lighter than a passive PFC circuit. To reduce the size and cost of passive filter elements, an active PFC operates at a higher switching frequency than the 50Hz/60Hz line frequency.

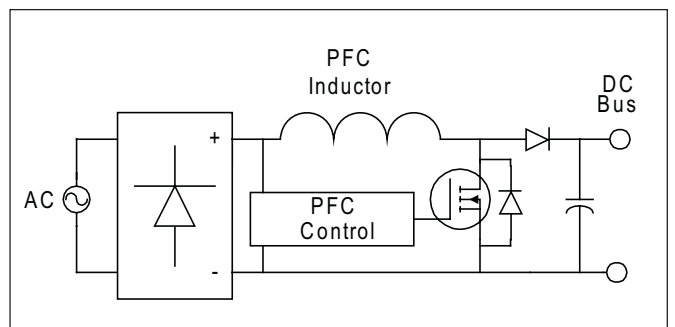

Figure 2: An active PFC circuit produces low THD and uses relatively small passive components.

Active PFC functions include:

- Active wave shaping of the input current
- Filtering of the high frequency switching
- Feedback sensing of the source current for waveform control
- Feedback control to regulate output voltage

Buck, boost, flyback and other converter topologies are used in active PFC circuits.

The DC-DC converter input capacitor also benefits from active PFC. The capacitor can be sized to filter the high frequency ripple of the active PFC circuit instead of a much larger capacitor that would be required to smooth the 50-60Hz input. The regulated input of the DC-DC converter also demands a lower range of duty cycle from the DC-DC converter. Other benefits of active PFC include increased “hold-over-time.” Hold over (brownout protection) benefits from always starting at the maximum voltage; and because energy in the capacitor is related to $\frac{1}{2}CV^2$, the capacitor can be much smaller than a capacitor in a converter without active PFC.

Boost Inductor

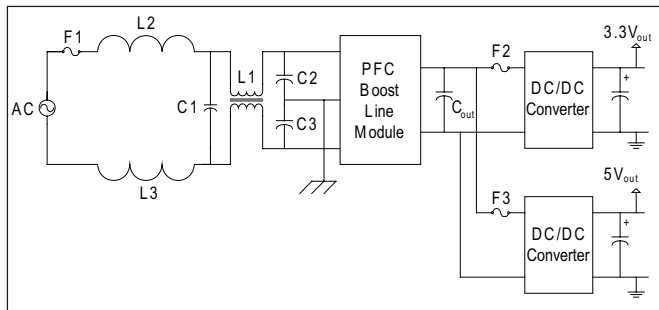

Figure 3: PFC Boost - Typical application circuit, 3.3 & 5V, 60W combined output power.

The boost-circuit based PFC topology is the most popular. It is an economical solution for complying with regulations. The inductance value is selected based on the desired current ripple in the boost inductor. The inductance value is expressed as follows.

$$L = \frac{V_{pk_in}(\min) * d(\max)}{f_s * \Delta i}$$

where:

- $V_{pk_in}(\min)$ is the peak minimum input voltage
- f_s is the switching frequency
- Δi is the ripple current
- $d(\max)$ is the maximum duty cycle expressed as:

$$d(\max) = \frac{1 - V_{pk_in}(\min)}{V_o} \quad \text{where } V_o \text{ is the output voltage}$$

The rms boost inductor current is expressed as:

$$I_L(\text{rms}) = \frac{I_{in}(\text{pk})}{\sqrt{2}} \text{ A}$$

Inductor Selection

Cooper Bussmann Coiltronics® PFC inductors are available for use with a wide variety of PFCs from 100W to 250W. They operate with controllers from several IC manufacturers to provide PFC supply solutions that utilize either passive or active PFC applications.

Coiltronics PFC inductors range from 200 μ H to 1.2mH. The standard input voltage range is 85V to 385V with different core materials such as ferrite, powder iron and Kool-Mu™ to provide significant low core loss. The E-core and toroidal geometries allow using thicker wire to decrease DC resistance and yield higher current capacity. Many vertical or horizontal through-hole mounting options are available with an operating temperature range of -20°C to $+105^{\circ}\text{C}$.

PFC Type	Appearance	Weight	PF Value	Impact on Environment	PFC Cost
None	With input voltage, switch or fixed input voltage	None	50~60%	Bad	None
Passive	With input voltage, switch or fixed input voltage	Heaviest	70~80%	Better	Normal
Active	Without input voltage switch	Normal	90~99.9%	Best	Expensive

Table 1: Comparison of passive and active PFC versus no PFC.

Fuses

AC Input Line Fuse

Product safety standards written by Underwriters Laboratories (UL) and the International Electrotechnical Commission (IEC) require fuses for primary AC power protection and secondary protection against any catastrophic failure within the input filter capacitors, PFC boost module, output electrolytic capacitors (C_{out}) or the DC-DC converters. The PFC boost module usually does not contain overcurrent protection; if a short-circuit is applied across its output terminals, there is no internal circuit opening device to safely interrupt the power. Without fuse protection in the AC input line (see fuse F1 in Figure 3), the boost converter is not protected.

Fusing the DC-DC converter input lines is essential for protection against a catastrophic DC-DC converter failure (see fuses F2 and F3 in Figure 3).

Protecting the DC-DC Converter

Although the primary input line fuse will eventually activate, DC fuses positioned right at the input to the DC-DC converters will limit the energy delivered by the hold-up capacitors (C_{out}) and will prevent failure to the PFC boost module.

Fuse time current curves (I [amps] versus t [time]) should be consulted for verification of the primary line fuse selection. The DC fuse should not open as a result of normal inrush currents flowing at supply startup. Inrush current is limited within most PFC modules to 5A peak (3.54A_{rms}) by an active inrush current-limiting circuit. Inrush current duration (t) increases with increasing output capacitance (C_{out}) and can be approximated by $t = (50) \times (C_{out})$.

Common Cooper Bussmann® fuses applied to the overcurrent protection points in the circuit of Figure 3 are:

- F1: RoHS compliant S501-2-R fast-acting 5 x 20mm ceramic tube fuse rated for 2A @ 250Vac
- F2 & F3: RoHS compliant PC-Tron fast-acting PCB through-hole fuse rated up to 250Vac/450Vdc. (Product codes PCB, PCC, PCD, PCE, PCF, PCH and PCI.)

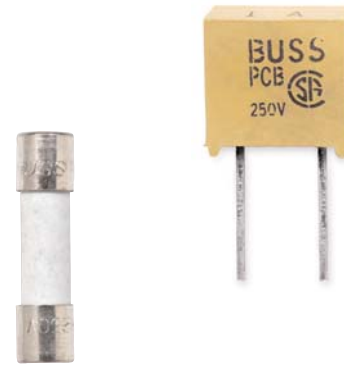

Figure 4: S501-2-R and PC-Tron Fuses

Coiltronics Inductors for Power Factor Correction

PFC Type	Part Number	Inductance	Aux Wdg	Geometry	Core Material	Mounting	Size (mm)	Output Power
Passive	CTX01-15789	1mH @ 3.4A	Yes	ER28L	Ferrite	Verticle	30 x 24 x 36	-
	CTX02-12236	500µH @ 2.6A	No	Toroid	Powder Iron	Horizontal	31.8 x 31.8 x 19.5	-
	CTX02-12378	769µH @ 2.6A	Yes	Toroid	Kool-Mu™/Sendust	Horizontal	34.3 x 34.3 x 18.3	-
	CTX22-16885	200µH @ 7.0A	Yes	Toroid	Powder Iron	Verticle	43 x 22 x 47	-
Active	CTX08-13679	1.2mH @ 4.7A	Yes	EE42x15	Ferrite	Horizontal	51 x 48 x 39	250W
	CTX16-15954	1.0mH @ 3.1A	Yes	ER28L	Ferrite	Verticle	30 x 24 x 36	100W
	CTX16-17309	200µH @ 2.0A	No	Toroid	Powder Iron	Verticle	35.2x33.5x22	200W
	CTX16-17769-R	340µH @ 5.3A	Yes	Toroid	Powder Iron	Horizontal	40 x 40 x 19.8	150W
	CTX16-18405-R	140µH @ 3.2A	No	Toroid	Kool-Mu™/Sendust	Horizontal	21x21x11	150W
	CTX22-15557	1.0mH @ 1.3A	Yes	EFD25	Ferrite	Horizontal	31 x 27 x 13	100W

Other inductors available for power factor correction.

For other inductor values and technical application assistance contact Cooper Bussmann at InductorTech@cooperindustries.com.

The Cooper Bussmann Coiltronics® brand of magnetics specializes in standard and custom solutions, offering the latest in state-of-the-art low-profile high power density magnetic components. We remain at the forefront of innovation and new technology to deliver the optimal mix of packaging, high efficiency and unbeatable reliability. Our designs utilize high frequency, low core loss materials, and new and custom core shapes in combination with innovative construction and packaging to provide designers with the highest performance parts available on the market. The Coiltronics Brand product line of power magnetics continually expands to satisfy shifts in technology and related market needs. Standard Product Categories include:

- Shielded Drum Inductors
- Unshielded Drum Inductors
- High Current Inductors
- Toroidal Inductors
- Specialty Magnetics
- Custom Magnetics

Please visit <http://www.cooperbussmann.com/datasheets/elx> to see data sheets on the wide variety of inductor solutions we have to offer.

For technical inquiries e-mail InductorTech@cooperindustries.com.

Order samples online - www.cooperbussmann.com

Mouser Electronics

Authorized Distributor

Click to View Pricing, Inventory, Delivery & Lifecycle Information:

Eaton:

[CTX02-12236](#) [CTX02-12378](#)