

Surge Protection Made Simple™

Photovoltaic Applications

Modular DIN Rail SPD Solutions



Type 4



Description

The Cooper Bussmann® multi-pole, modular Surge Protective Device (SPD) (with three-step DC switching device) features *easyID™* visual indication and optional remote contact signaling (floating changeover contact) for use in PV systems.

These complete surge protective devices are suitable for all PV systems in accordance with UL 1449 3rd Edition and IEC 60364-7-712. Includes a five year limited warranty.

These prewired solutions consist of a base and locking modules that feature a combined disconnection and short-circuiting (shunting) device with safe electrical isolation to prevent fire damage due to DC arcs. An integrated DC fuse allows safe module replacement without arc formation.

In case of insulation faults in the generator circuit, a reliable and tested fault-resistant Y circuit prevents damage to the surge protective devices.

The green and red visual indicator flags show the module protective status (green = good, red = replace). Apart from this visual indication, the remote signaling option features a three terminal floating changeover contact that can be used as a make or break contact depending on the particular monitoring system design employed.



BSPH___YPV(R)

easyID™ Visual Status Indication  Remote Signal Contact Available 

Dimensions - mm

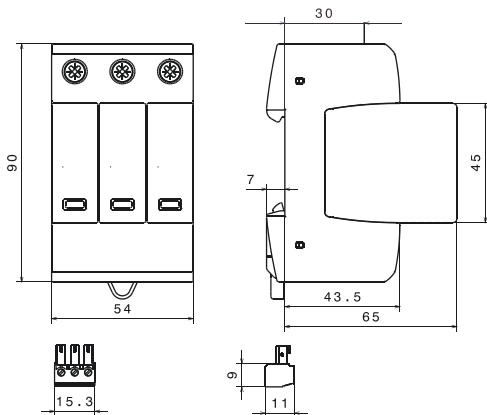

Shown with optional remote contact signaling

Module Circuit Diagrams

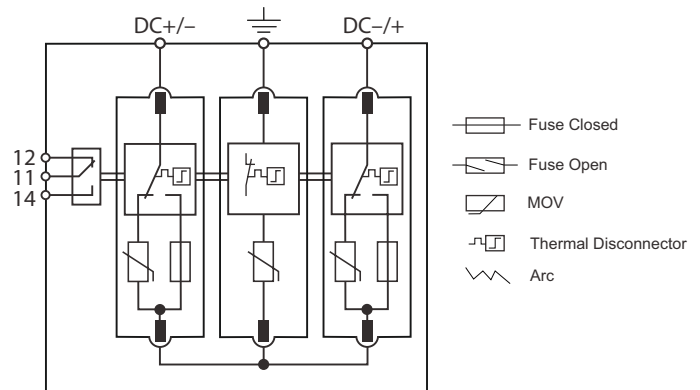

BSPH___YPV(R)

Shown with optional remote contact signaling

Short-Circuit Interrupting (SCI) Technology

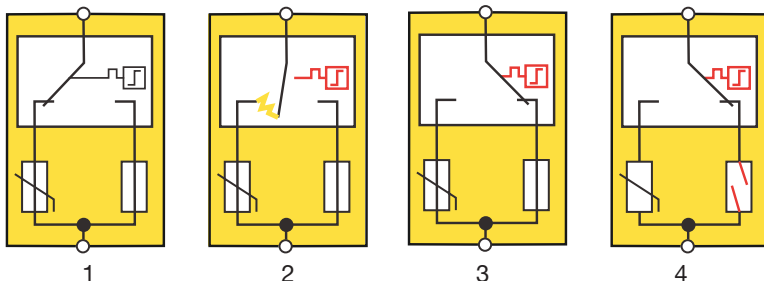

1. Original State
2. Disconnection Device Response
3. Arc Extinguishes
4. Safe Electrical Isolation

Ordering Information				
Nominal PV System Voltage		600Vdc	1000Vdc	1200Vdc
Catalog Numbers: (Base + Modules)	Without Remote Signaling	BSPH3600YPV	BSPH31000YPV	BSPH31200YPV
	With Remote Signaling	BSPH3600YPVR	BSPH31000YPVR	BSPH31200YPVR
Replacement Modules:	Outer (2)	BPH300YPV	BPH500YPV	BPH600YPV
	Center (1)	BPM300YPV	BPM500YPV	BPM600YPV
Specifications				
Nominal PV System Voltage		600V	1000V	1200V
MCOV [U_{CPV}]		700Vdc	1170Vdc	1200Vdc
Max System Discharge Current (8/20 μ s) [I_{max}]		40kA	40kA	30kA
Voltage Protection Level [U_P]		≤ 2.5 kV	≤ 4.0 kV	≤ 4.5 kV
Voltage Protection Level at 5kA [U_P]		≤ 2.0 kV	≤ 3.5 kV	≤ 4.0 kV
Integrated Fuse Breaking Capacity/Interrupting Rating		30kA/1000Vdc	30kA/1000Vdc	30kA/1200Vdc
Technology		Short-Circuit Interruption (SCI) Overcurrent Protection		
Operating Temperature Range [T_U]		-40°C to +80°C		
Nominal Discharge Current (8/20 μ s) [(DC+/DC-) --> PE] [I_n]		12.5kA		
Response Time [t_A]		≤ 25 ns		
Operating State/Fault Indication		Green (good)/Red (replace)		
Conductor Ratings and Cross-Sectional Area: Minimum		60/75°C 1.5mm ² /14AWG Solid/Flexible		
	Maximum	60/75°C 35mm ² /2AWG Stranded/25mm ² /4AWG Flexible		
Mounting		35mm DIN Rail per EN 60715		
Enclosure Material		UL 94V0 Thermoplastic		
Degree of Protection		IP20		
Capacity		3 Modules, DIN 43880		
Standards Information:	UL	UL 1449 3 rd Edition (Type 2)*		
	IEC	IEC 61643-11 Type 2, IEC 61643-1 Class II		
Product Warranty		Five Years**		
Remote Contact Signaling				
Remote Contact Signaling Type		Changeover Contact		
AC Switching Capacity (Volts/Amps)		250V/0.1A		
DC Switching Capacity (Volts/Amps)		250V/0.1A; 125V/0.2A; 75V/0.5A		
Conductor Ratings and Cross-Sectional Area for Remote Contact Signal Terminals		60/75°C Max. 1.5mm ² /14AWG Solid/Flexible		
Ordering Information		Order from Catalog Numbers Above		

Typical Application Schematics

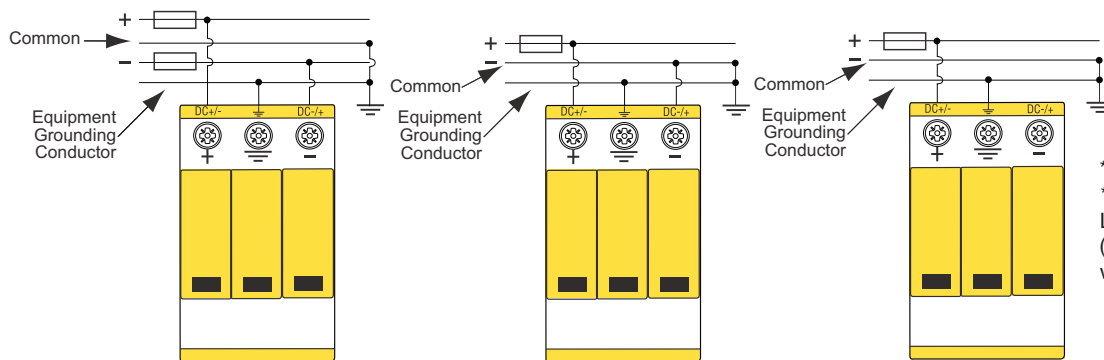

Application A
Two energized poles/modes
600, 1000 & 1200Vdc systems

Application B
One energized pole/mode
600Vdc & 1000Vdc*** systems only

Application C
One energized pole/mode
600Vdc & 1000Vdc*** systems only
(Max. system discharge current
(8/20 μ s) [I_{max}] 25kA)

*Does not apply to 1200Vdc.
** See Cooper Bussmann SPD Limited Warranty Statement (3A1502) for details at www.cooperbussmann.com/surge

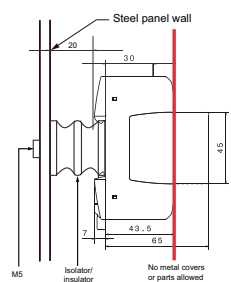

1000Vdc One energized pole/mode mounting detail.

***BSPH31000YPV(R) 1000Vdc one energized pole/mode requires the following:

1. Use a suitable electrical insulator to keep a 10mm min. safety distance from the PV-SPD and other grounded parts in the housing as shown
2. No metal covers are in the area of the module release buttons as shown.

The only controlled copy of this Data Sheet is the electronic read-only version located on the Cooper Bussmann Network Drive. All other copies of this document are by definition uncontrolled. This bulletin is intended to clearly present comprehensive product data and provide technical information that will help the end user with design applications. Cooper Bussmann reserves the right, without notice, to change design or construction of any products and to discontinue or limit distribution of any products. Cooper Bussmann also reserves the right to change or update, without notice, any technical information contained in this bulletin. Once a product has been selected, it should be tested by the user in all possible applications.

Mouser Electronics

Authorized Distributor

Click to View Pricing, Inventory, Delivery & Lifecycle Information:

[Eaton:](#)

[BSPH31000YPV](#) [BSPH31000YPVR](#) [BSPH3600YPVR](#) [BSPH3600YPV](#)