

USERS MUST ENSURE CORRECT REVISION

REVISIONS				
REV. SYM.	E.C.O. NUMBER	DESCRIPTION	BY DATE	APP'D DATE
1		ORIGINAL RELEASE	JWJ 1/14/00	RRR 1/14/00
2		NOTE 1 EQUIVALENT WAS 90302-1	TD 8-11-11	
3		REVISED FOR CLARITY	ENF 10-12-15	

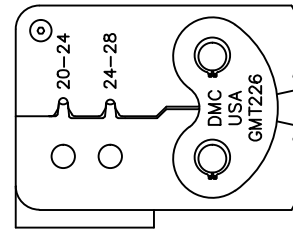
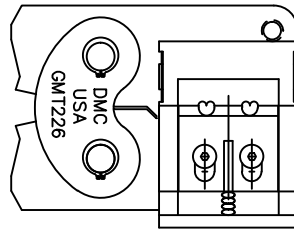
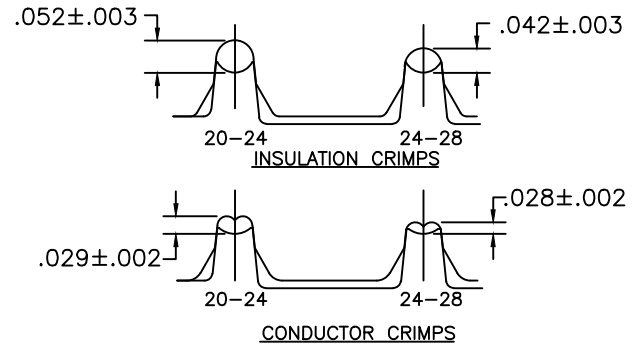
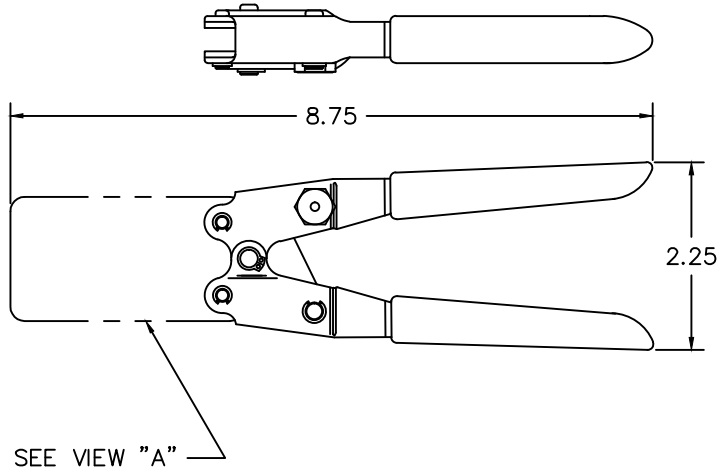

VIEW "A"

**UNCONTROLLED DOCUMENT
WILL NOT BE UPDATED**
DIMENSIONS IN INCHES - UNLESS OTHERWISE SPECIFIED

2. FOR GAGE VERIFICATION, CRIMP ϕ .062 50/50 SOLID SOLDER AND MEASURE WITH A BLADE MICROMETER.
1. AMP 91503-1 OR 58448-2 EQUIVALENT.

NOTES:

RESTRICTED & CONFIDENTIAL CONFIDENTIAL PROPERTY OF DANIELS MANUFACTURING CORP. NOT TO BE DISCLOSED TO OTHERS, REPRODUCED OR USED FOR ANY OTHER PURPOSE, EXCEPT AS AUTHORIZED IN WRITING BY DANIELS MANUFACTURING. MUST BE RETURNED TO DANIELS MANUFACTURING CORP. ON COMPLETION OF ORDER OR OTHER PURPOSE FOR WHICH LENT.	MATERIAL	ITEM	PART NO.	QTY.	DESCRIPTION/REMARKS				
	HEAT TREAT	DRN.	J. JOYCE	DATE	 DANIELS MANUFACTURING CORP. ORLANDO, FLORIDA CAGE 11851				
		CHK'D.	RRR	DATE					
	FINISH	APP'D.		DATE	TITLE	CRIMP TOOL ENVELOPE DRAWING			
APP'D.			DATE	WHERE USED:					
DO NOT SCALE DRAWING	NOTE:		THIS DRAWING IS AN OUTLINE DRAWING OF THE RESPECTIVE DMC PART NUMBER INDICATED. ACTUAL DMC PART NUMBER IS DRAWING NUMBER WITHOUT THE "-ENV" SUFFIX.		SIZE	SCALE	CAD P/N	SHEET	OF
			B	NTS	GMT226-ENV	1	1		
			POSTING	DWG. NO.		GMT226-ENV	REV.	3	

Mouser Electronics

Authorized Distributor

Click to View Pricing, Inventory, Delivery & Lifecycle Information:

[Daniels Manufacturing:](#)

[GMT226](#)