

Heat sink

Heat sink is prepared in DAS · DPA series.

Chart: List of Heat sink for DAS · DPA series

| No | Model designagion | | Size [mm] | | | Heat resistance [°C/W] | | Style |
|----|------------------------|-----------|-----------|------|-------|------------------------|-------------|------------|
| | | | H | W | D | Convection | Forced Air | |
| 1 | For DAS50 | F-DA 50A | 12 | 57.5 | 114.5 | 11.3 | Refer Fig.1 | Vertical |
| 2 | | F-DA 50B | | | | 9.3 | | Horizontal |
| 3 | | F-DA 50C | 30 | | | 3.8 | Refer Fig.2 | Vertical |
| 4 | | F-DA 50D | | | | 3.6 | | Horizontal |
| 5 | For DAS100 and DPA500F | F-DA 100A | 12 | 57.5 | 129.5 | 10.9 | Refer Fig.3 | Vertical |
| 6 | | F-DA 100B | | | | 8.3 | | Horizontal |
| 7 | | F-DA 100C | 30 | | | 3.6 | Refer Fig.4 | Vertical |
| 8 | | F-DA 100D | | | | 3.2 | | Horizontal |

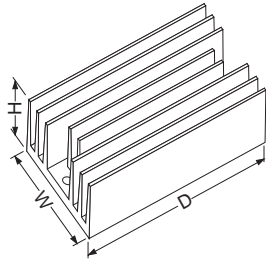

Vertical type

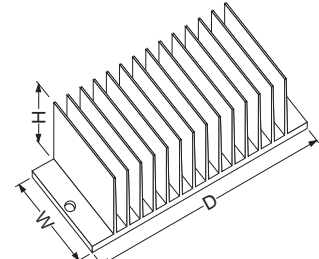

Horizontal type

F-DA50A, F-DA50B Heat resistance (Forced air)

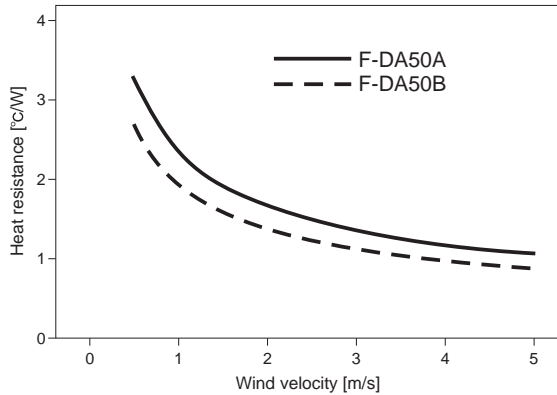

Fig.1 F-DA50A, F-DA50B Heat sink heat resistance

F-DA100A, F-DA100B Heat resistance (Forced air)

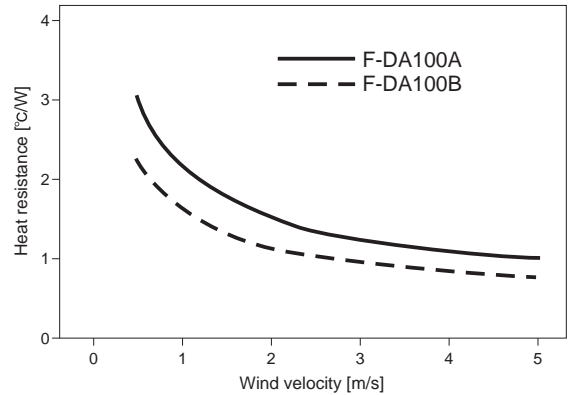

Fig.3 F-DA100A, F-DA100B Heat sink heat resistance

F-DA50C, F-DA50D Heat resistance (Forced air)

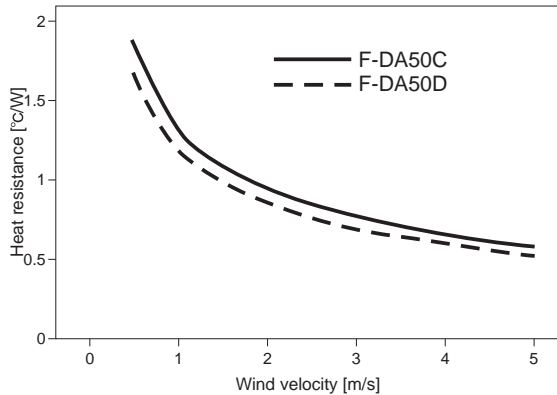

Fig.2 F-DA50C, F-DA50D Heat sink heat resistance

F-DA100C, F-DA100D Heat resistance (Forced air)

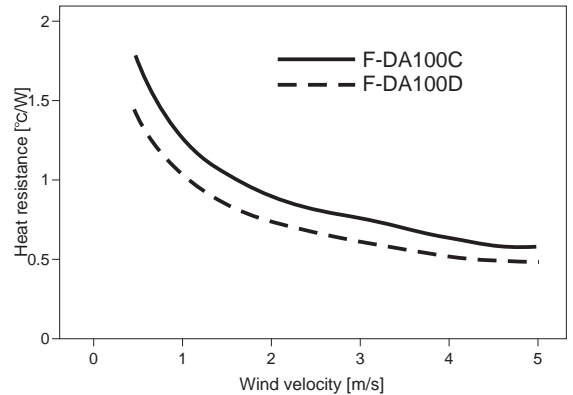

Fig.4 F-DA100C, F-DA100D Heat sink heat resistance

Heat sink

Heat sink is prepared in CBS series.

Chart: List of Heat sink for CBS series

| No | Model | Size [mm] | | | Thermal resistance [°C/W] | | Style |
|----|----------|-----------|------|------|---------------------------|-------------|------------|
| | | H | W | D | Convection (0.1m/s) | Forced Air | |
| 1 | F-CBS-F1 | 12.7 | 57.9 | 61.5 | 7.5 | Refer Fig.7 | Vertical |
| 2 | F-CBS-F2 | 12.7 | 58.4 | 61.0 | | | Horizontal |
| 3 | F-CBS-F3 | 25.4 | 57.9 | 61.5 | 4.6 | | Vertical |
| 4 | F-CBS-F4 | 25.4 | 58.4 | 61.0 | | | Horizontal |
| 5 | F-CBS-F5 | 38.1 | 57.9 | 61.5 | 3.0 | | Vertical |
| 6 | F-CBS-F6 | 38.1 | 58.4 | 61.0 | | | Horizontal |

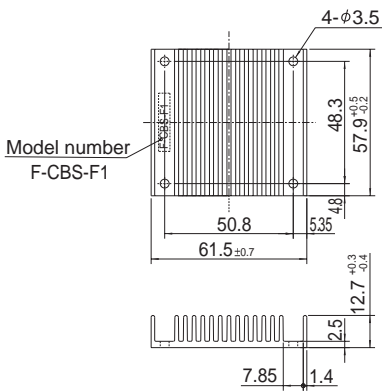

Fig.1 F-CBS-F1 external view

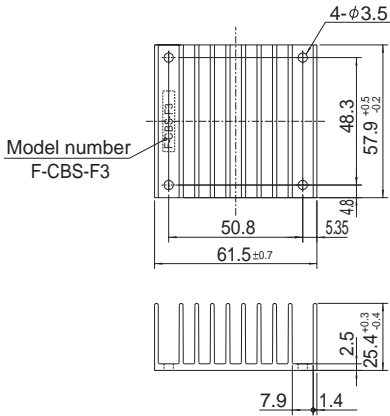

Fig.2 F-CBS-F3 external view

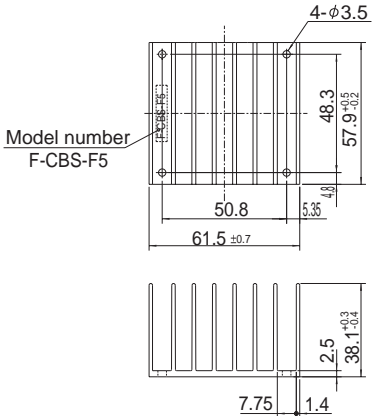

Fig.3 F-CBS-F5 external view

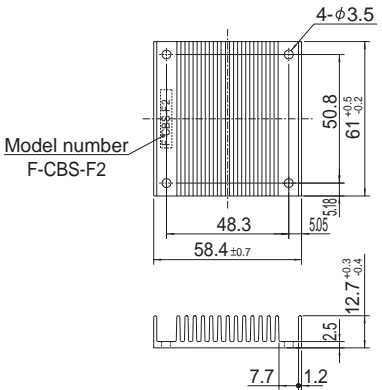

Fig.4 F-CBS-F2 external view

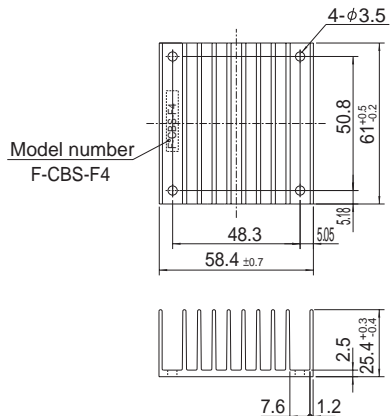

Fig.5 F-CBS-F4 external view

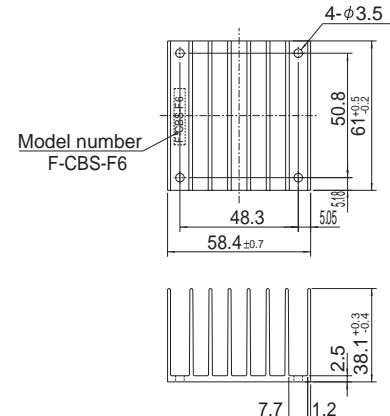

Fig.6 F-CBS-F6 external view

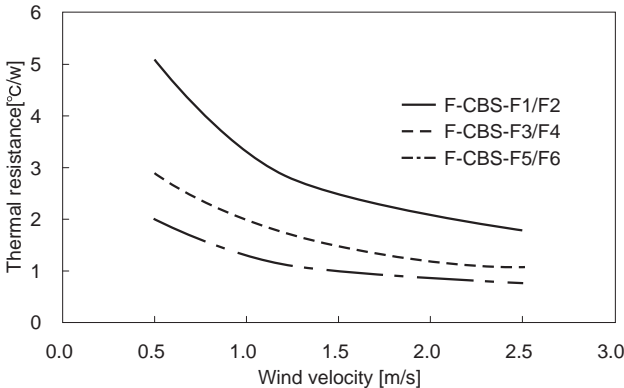

Fig.7 Thermal resistance of heat sink(Forced air)

Mouser Electronics

Authorized Distributor

Click to View Pricing, Inventory, Delivery & Lifecycle Information:

Cosel:

[F-DA50C](#) [F-DA100C](#) [F-DA100B](#) [F-DA50B](#) [F-DA50A](#) [F-DA100D](#) [F-DA50D](#) [F-DA100A](#)