

Product Specification

4 Gigabit RoHS Compliant Long-Wavelength SFP Transceiver

FTLF1424P2xCR and FTLF1424P2xCD

PRODUCT FEATURES

- Up to 4.25Gb/s bi-directional data links
- Hot-pluggable SFP footprint
- Built-in digital diagnostic functions
- 1310nm DFB laser transmitter
- Duplex LC connector
- RoHS compliant and Lead Free
- Up to 10 km on 9/125µm SMF
- Metal enclosure, for lower EMI
- Single 3.3V power supply
- Commercial operating temperature range: -10°C to 70°C



APPLICATIONS

- Tri Rate 1.06 / 2.125 / 4.25 Gb/s Fibre Channel
- 1.25Gb/s Gigabit Ethernet (Rate selectable version)

Finisar's FTLF1424P2xCR and FTLF1424P2xCD Small Form Factor Pluggable (SFP) transceivers are compatible with the Small Form Factor Pluggable Multi-Sourcing Agreement (MSA)¹. They are compatible with Fibre Channel per FC-PI-2 Rev. 10.0². Rate selectable versions are also simultaneously compatible with Gigabit Ethernet as specified in IEEE Std 802.3³. The product is RoHS compliant and lead-free per Directive 2002/95/EC⁴ and Finisar Application Note AN-2038.

PRODUCT SELECTION

FTLF1424P2xCy

x	W	Wide Extraction Bail
	B	Narrow Extraction Bail
y	R	Non Rate Selectable - 1x, 2x, 4x Fibre Channel
	D	Rate Selectable - 1x, 2x, 4x Fibre Channel and Gigabit Ethernet

I. Pin Descriptions

Pin	Symbol	Name/Description	Ref.
1	V _{EET}	Transmitter Ground (Common with Receiver Ground)	1
2	T _{FAULT}	Transmitter Fault. Not supported.	
3	T _{DIS}	Transmitter Disable. Laser output disabled on high or open.	2
4	MOD_DEF(2)	Module Definition 2. Data line for Serial ID.	3
5	MOD_DEF(1)	Module Definition 1. Clock line for Serial ID.	3
6	MOD_DEF(0)	Module Definition 0. Grounded within the module.	3
7	Rate Select	Open or Low = 1.063 Gb/s or 2.125 Gb/s Fibre Channel, 1.25 Gb/s Gigabit Ethernet (Low Bandwidth) High = 2.125 or 4.25 Gb/s Fibre Channel (High Bandwidth)	4
8	LOS	Loss of Signal indication. Logic 0 indicates normal operation.	5
9	V _{EER}	Receiver Ground (Common with Transmitter Ground)	1
10	V _{EER}	Receiver Ground (Common with Transmitter Ground)	1
11	V _{EER}	Receiver Ground (Common with Transmitter Ground)	1
12	RD-	Receiver Inverted DATA out. AC Coupled	
13	RD+	Receiver Non-inverted DATA out. AC Coupled	
14	V _{EER}	Receiver Ground (Common with Transmitter Ground)	1
15	V _{CCR}	Receiver Power Supply	
16	V _{CCT}	Transmitter Power Supply	
17	V _{EET}	Transmitter Ground (Common with Receiver Ground)	1
18	TD+	Transmitter Non-Inverted DATA in. AC Coupled.	
19	TD-	Transmitter Inverted DATA in. AC Coupled.	
20	V _{EET}	Transmitter Ground (Common with Receiver Ground)	1

Notes:

- Circuit ground is internally isolated from chassis ground.
- Laser output disabled on T_{DIS} > 2.0V or open, enabled on T_{DIS} < 0.8V.
- Should be pulled up with 4.7k - 10 kohms on host board to a voltage between 2.0V and 3.6V. MOD_DEF(0) pulls line low to indicate module is plugged in.
- For Rate Selectable version only:** In accordance with SFF Committee SFF-8079 Draft, Rev.1.6, Table 3. Note that rate select can also be set through 2-wire bus in accordance with SFF-8472⁶ at Bit 3, Byte 110, Address A2h (note: writing '1' selects full bandwidth operation). Rate select is the logic OR of the input state of Rate Select Pin and 2-wire bus. Non Rate Selectable version can operate at 1x, 2x, 4x Fibre Channel independent of rate select pin setting.
- LOS is open collector output. Should be pulled up with 4.7k - 10 kohms on host board to a voltage between 2.0V and 3.6V. Logic 0 indicates normal operation; logic 1 indicates loss of signal.

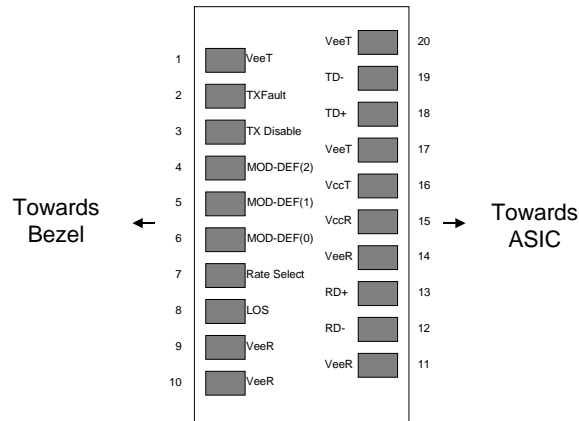

Pinout of Connector Block on Host Board

II. Absolute Maximum Ratings

Parameter	Symbol	Min	Typ	Max	Unit	Ref.
Maximum Supply Voltage	V _{CC}	-0.5		4.5	V	
Storage Temperature	T _S	-40		85	°C	
Case Operating Temperature	T _{OP}	-10		70	°C	
Relative Humidity	RH	0		85	%	1

III. Electrical Characteristics (T_{OP} = -10 to 70 °C, V_{CC} = 3.00 to 3.60 Volts)

Parameter	Symbol	Min	Typ	Max	Unit	Ref.
Supply Voltage	V _{CC}	3.00		3.60	V	
Supply Current	I _{CC}		200	300	mA	
Transmitter						
Input differential impedance	R _{in}		100		Ω	2
Single ended data input swing	V _{in,pp}	250		1200	mV	
Transmit Disable Voltage	V _D	V _{CC} – 1.3		V _{CC}	V	3
Transmit Enable Voltage	V _{EN}	V _{EE}		V _{EE} + 0.8	V	
Transmit Disable Assert Time				10	us	
Receiver						
Single ended data output swing	V _{out,pp}	250		800	mV	4
Data output rise/fall time < 4.25 Gb/s	t _r , t _f			175	ps	5
Data output rise/fall time = 4.25 Gb/s	t _r , t _f			120	ps	5
LOS Fault	V _{LOS fault}	V _{CC} – 0.5		V _{CC,HOST}	V	6
LOS Normal	V _{LOS norm}	V _{EE}		V _{EE} +0.5	V	6
Power Supply Rejection	PSR	100			mVpp	7
Deterministic Jitter Contribution < 4.25 Gb/s	RX Δ DJ			51.7	ps	8
Total Jitter Contribution < 4.25 Gb/s	RX Δ TJ			122.4	ps	
Deterministic Jitter Contribution = 4.25 Gb/s	RX Δ DJ			25.9	ps	8
Total Jitter Contribution = 4.25 Gb/s	RX Δ TJ			61.2	ps	

Notes:

1. Non-condensing.
2. AC coupled.
3. Or open circuit.
4. Into 100 ohm differential termination.
5. 20 – 80 %
6. LOS is LVTTTL. Logic 0 indicates normal operation; logic 1 indicates no signal detected.
7. All transceiver specifications are compliant with a power supply sinusoidal modulation of 20 Hz to 1.5 MHz up to specified value applied through the power supply filtering network shown on page 23 of the Small Form-factor Pluggable (SFP) Transceiver MultiSource Agreement (MSA)¹, September 14, 2000. The Power Supply Rejection applies for a supply voltage range of 3.15 to 3.6 V.
8. Measured with DJ-free data input signal. In actual application, output DJ will be the sum of input DJ and Δ DJ.

IV. Optical Characteristics (T_{OP} = -10 to 70 °C, V_{CC} = 3.00 to 3.60 Volts)

Parameter	Symbol	Min	Typ	Max	Unit	Ref.
Transmitter						
Output Opt. Power, Non-Rate Selectable Version	P _{O,NR}	-8.4		-1	dBm	1
Output Opt. Power, Rate Selectable Version	P _{O,RH}	-8.4		-1	dBm	2
Output Opt. Power, Rate Selectable Version	P _{O,RL}	-9.5		-3	dBm	3
Optical Wavelength	λ	1285		1345	nm	4
Spectral Width	σ			1	nm	4
Optical Modulation Amplitude	OMA	290			μ W	4,5
Optical Modulation Amplitude \leq 2.125 Gb/s	OMA	174			μ W	4,5
Optical Rise/Fall Time = 4.25 Gb/s	t _r / t _f			90	ps	6
Optical Rise/Fall Time \leq 2.125 Gb/s	t _r / t _f			160	ps	7
RIN				-118	dB/Hz	
Deterministic Jitter Contribution = 4.25 Gb/s	TX Δ DJ			28.2	ps	8
Total Jitter Contribution = 4.25 Gb/s	TX Δ TJ			59.8	ps	
Deterministic Jitter Contribution \leq 2.125 Gb/s	TX Δ DJ			56.5	ps	8
Total Jitter Contribution \leq 2.125 Gb/s	TX Δ TJ			119	ps	
Optical Extinction Ratio = 1.25 Gb/s	ER	9			dB	9
Receiver						
Receiver Sensitivity = 4.25 Gb/s	R _{SENSr}			0.029 -18	mW dBm	10 11
Receiver Sensitivity = 2.125 Gb/s	R _{SENS2}			0.015 -21	mW dBm	10 11
Receiver Sensitivity = 1.06 Gb/s	R _{SENS1}			0.015 -22	mW dBm	10 11
Receiver Sensitivity = 1.25 Gb/s	R _{SENS1}			-22	dBm	12,13
Stressed RX sens. = 1.25 Gb/s				-14.5	dBm	
Average Received Power	R _{XMAX}			0	dBm	
Receiver Elec. 3 dB cutoff freq.				1500	MHz	13
Receiver Elec. 3 dB cutoff freq.				2500	MHz	14
Optical Center Wavelength	λ_c	1260		1600	nm	
Return Loss		12			dB	
LOS De-Assert	LOS _D			-19	dBm	
LOS Assert	LOS _A	-30			dBm	
LOS Hysteresis		0.5			dB	

Notes:

- Class 1 Laser Safety per FDA/CDRH and EN (IEC) 60825 regulations.
- High Bandwidth Mode. Class 1 Laser Safety per FDA/CDRH and EN (IEC) 60825 regulations.
- Low Bandwidth Mode. Class 1 Laser Safety per FDA/CDRH and EN (IEC) 60825 regulations.
- Also specified to meet curves in FC-PI-2 Rev 10.0 Figures 18, 19, and 20, which allow trade-off between wavelength, spectral width and OMA.
- Equivalent extinction ratio specification for Fibre Channel. Allows smaller ER at higher average power.
- Unfiltered, 20-80%. Complies with FC 4x eye mask when filtered.
- Unfiltered, 20-80%. Complies with IEEE 802.3 (Gig. E), FC 1x and 2x eye masks when filtered.
- Measured with DJ-free data input signal. In actual application, output DJ will be the sum of input DJ and Δ DJ.
- Applicable for Rate Selectable version only in low bandwidth mode.

10. Measured with conformance signals defined in FC-PI-2 Rev. 10.0 specifications. Value in OMA. Measured with PRBS 2^7-1 at 10^{-12} BER
11. Measured with conformance signals defined in FC-PI-2 Rev. 10.0 specifications. Represents sensitivity based on OMA spec, as corrected to incoming Extinction Ratio of 13 dB (for example, at 5.75dB incoming extinction ratio, an OMA of 0.029 mW corresponds to -16 dBm sensitivity). Measured with PRBS 2^7-1 at 10^{-12} BER .
12. Rate Selectable version in low bandwidth mode with minimum 9dB extinction ratio.
13. Rate Selectable version in low bandwidth mode.
14. Rate Selectable version in high bandwidth mode.

V. General Specifications

Parameter	Symbol	Min	Typ	Max	Units	Ref.
Data Rate	BR	1062		4250	Mb/sec	1
Bit Error Rate	BER			10^{-12}		2
Max. Supported Link Length on 9/125 μ m SMF @ 4X Fibre Channel	L_{MAX1}		10		km	3
Max. Supported Link Length on 9/125 μ m SMF @ 1X and 2X Fibre Channel	L_{MAX2}		20		km	3,4
Max. Supported Link Length on 9/125 μ m SMF @ Gigabit Ethernet	L_{MAX3}		20		km	3,4

Notes:

1. Gigabit Ethernet and 1x/2x/4x Fibre Channel compliant.
2. Tested with a PRBS 2^7-1 test pattern.
3. Distances are based on FC-PI-2 Rev. 10.0 and IEEE 802.3 standards.
4. Distances are indicative only. Please refer to the Optical Specifications in Section IV to calculate a more accurate link budget based on specific conditions in your application.

VI. Environmental Specifications

These Finisar 1310nm Commercial Temperature SFP transceivers have an operating temperature range from -10°C to $+70^{\circ}\text{C}$ case temperature.

Parameter	Symbol	Min	Typ	Max	Units	Ref.
Case Operating Temperature	T_{op}	-10		70	$^{\circ}\text{C}$	
Storage Temperature	T_{sto}	-40		85	$^{\circ}\text{C}$	

VII. Regulatory Compliance

Finisar transceivers are Class 1 Laser Products and comply with US FDA regulations. These products are certified by TÜV and CSA to meet the Class 1 eye safety requirements of EN (IEC) 60825 and the electrical safety requirements of EN (IEC) 60950. Copies of certificates are available at Finisar Corporation upon request.

VIII. Digital Diagnostic Functions

Finisar FTLF1424P2xCR and FTLF1424P2xCD SFP transceivers support the 2-wire serial communication protocol as defined in the SFP MSA¹. It is very closely related to the E²PROM defined in the GBIC standard, with the same electrical specifications.

The standard SFP serial ID provides access to identification information that describes the transceiver's capabilities, standard interfaces, manufacturer, and other information.

Additionally, Finisar SFP transceivers provide a unique enhanced digital diagnostic monitoring interface, which allows real-time access to device operating parameters such as transceiver temperature, laser bias current, transmitted optical power, received optical power and transceiver supply voltage. It also defines a sophisticated system of alarm and warning flags, which alerts end-users when particular operating parameters are outside of a factory set normal range.

The SFP MSA defines a 256-byte memory map in E²PROM that is accessible over a 2-wire serial interface at the 8 bit address 1010000X (A0h). The digital diagnostic monitoring interface makes use of the 8 bit address 1010001X (A2h), so the originally defined serial ID memory map remains unchanged. The interface is identical to, and is thus fully backward compatible with both the GBIC Specification and the SFP Multi Source Agreement. The complete interface is described in Finisar Application Note AN-2030: "Digital Diagnostics Monitoring Interface for SFP Optical Transceivers".

The operating and diagnostics information is monitored and reported by a Digital Diagnostics Transceiver Controller (DDTC) inside the transceiver, which is accessed through a 2-wire serial interface. When the serial protocol is activated, the serial clock signal (SCL, Mod Def 1) is generated by the host. The positive edge clocks data into the SFP transceiver into those segments of the E²PROM that are not write-protected. The negative edge clocks data from the SFP transceiver. The serial data signal (SDA, Mod Def 2) is bi-directional for serial data transfer. The host uses SDA in conjunction with SCL to mark the start and end of serial protocol activation. The memories are organized as a series of 8-bit data words that can be addressed individually or sequentially.

For more information, please see the SFP MSA documentation^{1,5} or Finisar Application Note AN-2030.

FTLF1424P2xCR and FTLF1424P2xCD transceivers can be used in host systems that require either internally or externally calibrated digital diagnostics.

Please note that evaluation board FDB-1018 is available with Finisar ModDEMO software that allows simple to use communication over the 2-wire serial interface.

IX. Mechanical Specifications

Finisar’s Small Form Factor Pluggable (SFP) transceivers are compatible with the dimensions defined by the SFP Multi-Sourcing Agreement (MSA)³.

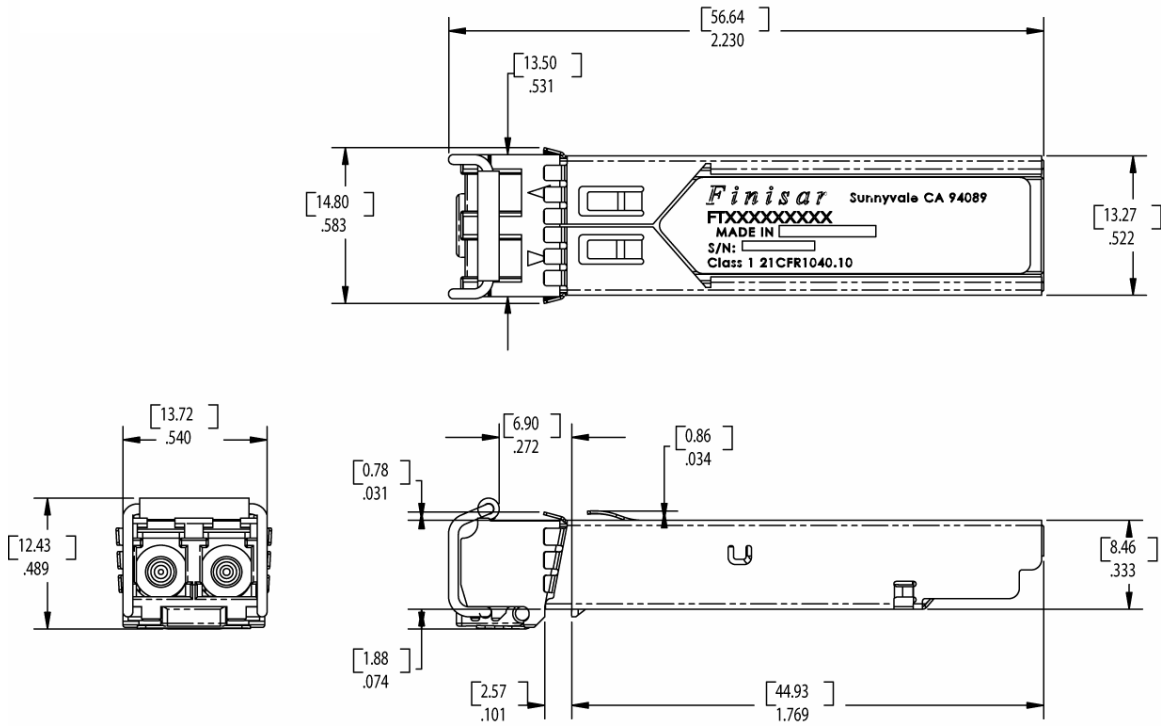

FTLF1424P2BCy

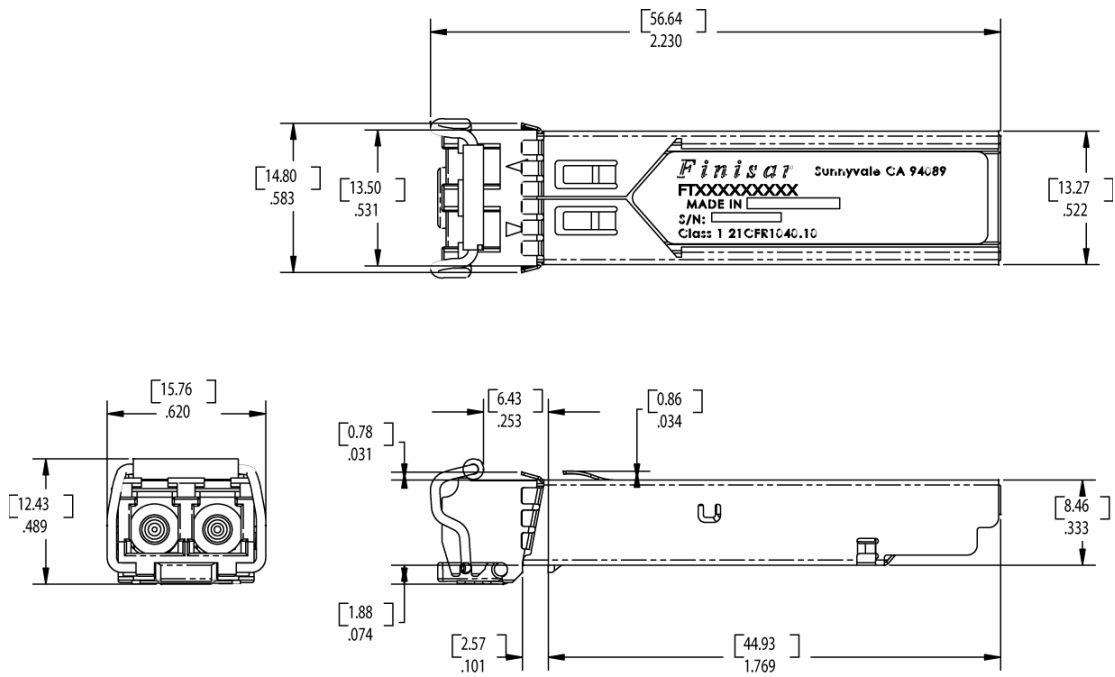

FTLF1424P2WCy

X. PCB Layout and Bezel Recommendations

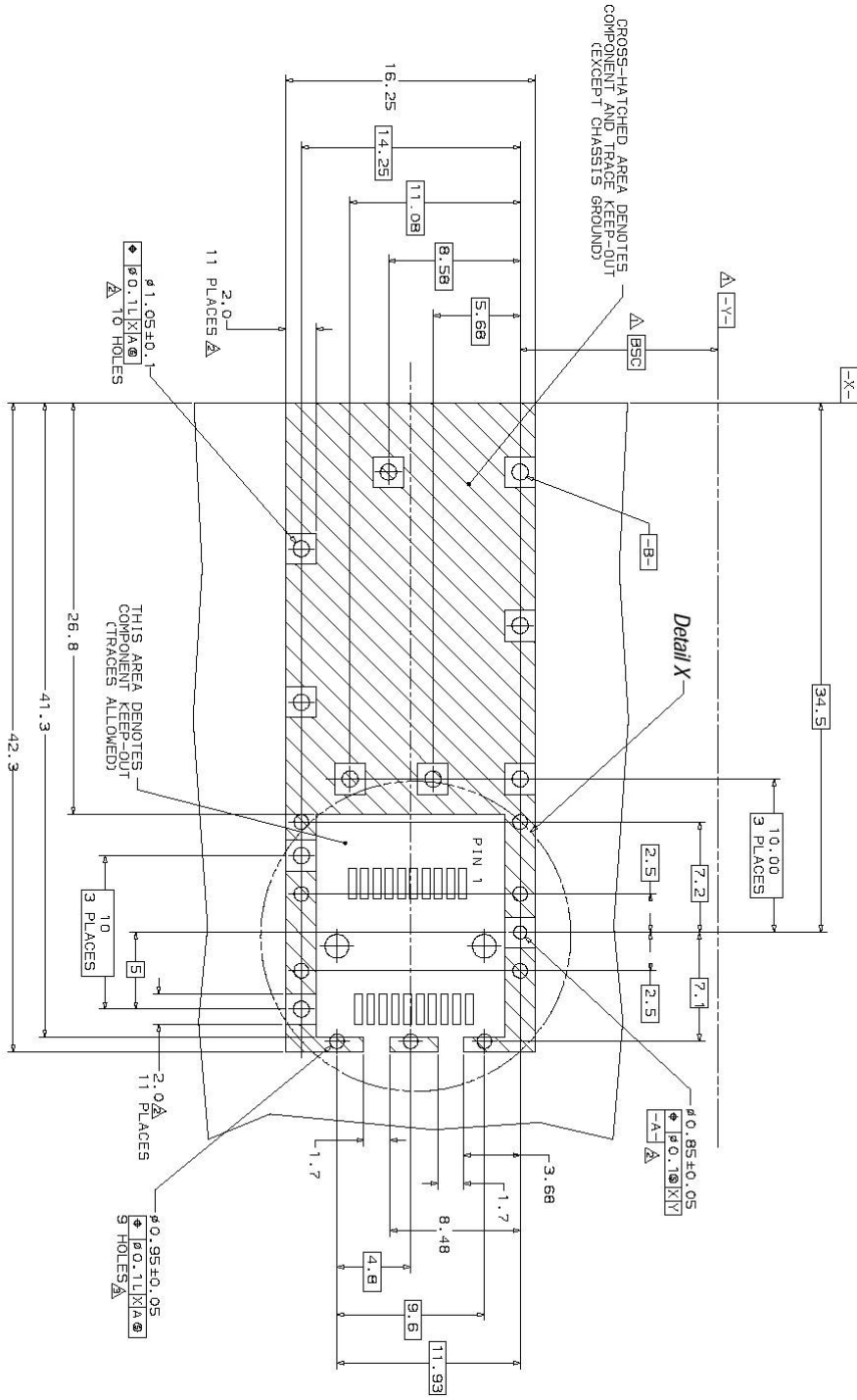

- △ Datum and Basic Dimension Established by Customer
- ▽ Pads and Vias are Chassis Ground, 11 Places
- △ Through Holes are Unplated

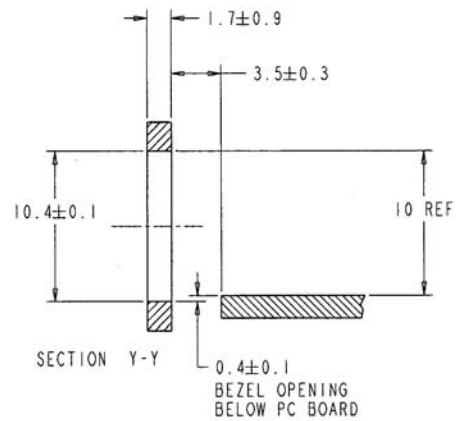
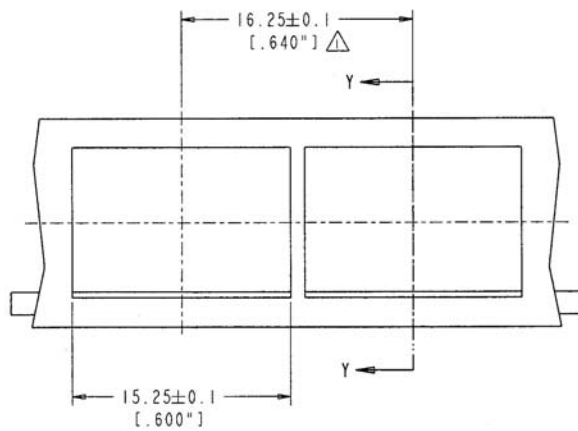
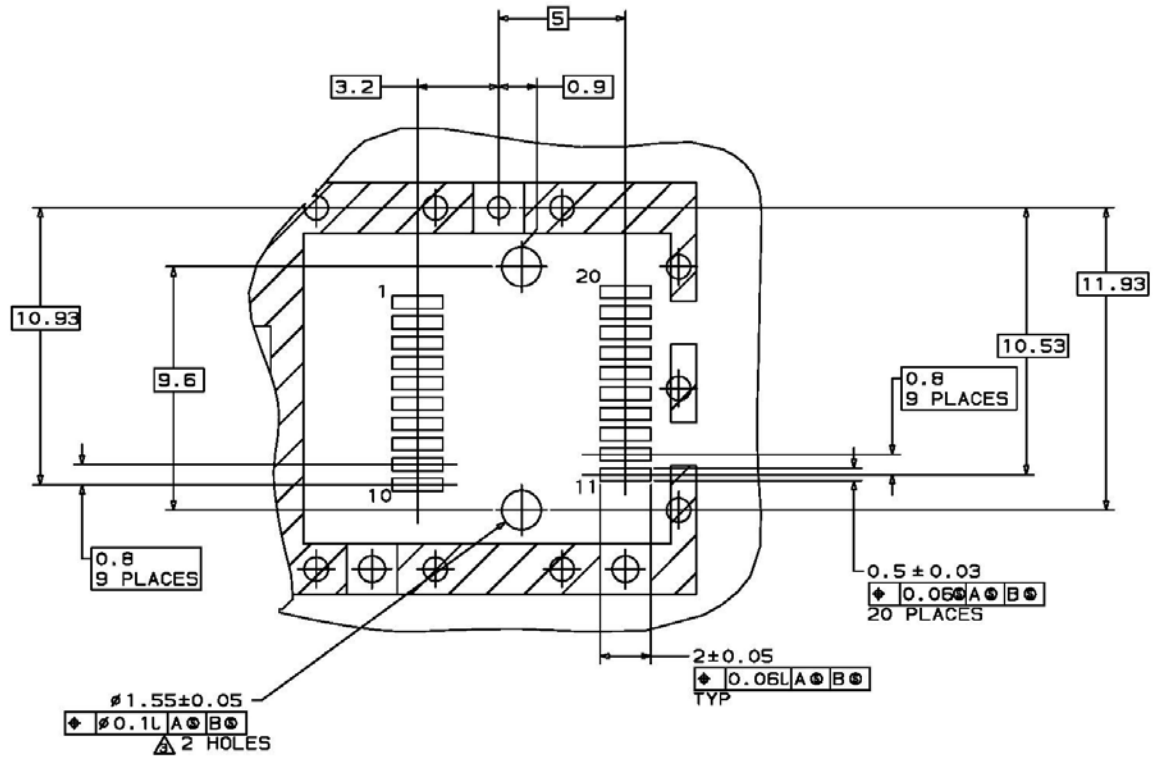

NOTES:

- 1. \triangle MINIMUM PITCH ILLUSTRATED, ENGLISH DIMENSIONS ARE FOR REFERENCE ONLY
- 2. NOT RECOMMENDED FOR PCI EXPANSION CARD APPLICATIONS

XI. References

1. Small Form-factor Pluggable (SFP) Transceiver Multi-source Agreement (MSA), September 14, 2000.
2. “Fibre Channel Draft Physical Interface Specification (FC-PI-2 Rev. 10.0)”. American National Standard for Information Systems.
3. IEEE Std 802.3, 2002 Edition, Clause 38, PMD Type 1000BASE-LX. IEEE Standards Department, 2002.
4. Directive 2002/95/EC of the European Council Parliament and of the Council, “on the restriction of the use of certain hazardous substances in electrical and electronic equipment.” January 27, 2003.
5. “Digital Diagnostics Monitoring Interface for Optical Transceivers”. SFF Document Number SFF-8472, Revision 9.3.

XII. For More Information

Finisar Corporation
1389 Moffett Park Drive
Sunnyvale, CA 94089-1133
Tel. 1-408-548-1000
Fax 1-408-541-6138
sales@finisar.com
www.finisar.com

Mouser Electronics

Authorized Distributor

Click to View Pricing, Inventory, Delivery & Lifecycle Information:

Finisar:

[FTLF1424P2BCD](#) [FTLF1424P2BCR](#) [FTLF1424P2BTD](#) [FTLF1424P2BTR](#)