



**austriamicrosystems AG**

**is now**

**ams AG**

The technical content of this austriamicrosystems datasheet is still valid.

**Contact information:**

**Headquarters:**

ams AG  
Tobelbaderstrasse 30  
8141 Unterpremstaetten, Austria  
Tel: +43 (0) 3136 500 0  
e-Mail: [ams\\_sales@ams.com](mailto:ams_sales@ams.com)

Please visit our website at [www.ams.com](http://www.ams.com)

# AS1108

## 4-Digit LED Display Driver

### 1 General Description

The AS1108 is a compact display driver for 7-segment numeric displays of up to 4 digits. The device can be programmed via SPI, QSPI, and Microwire as well as a conventional 4-wire serial interface.

The device includes an integrated BCD code-B/HEX decoder, multiplex scan circuitry, segment and display drivers, and a 32-bit memory. Internal memory stores the LED settings, eliminating the need for continuous device reprogramming.

Every segment can be individually addressed and updated separately. Only one external resistor ( $R_{SET}$ ) is required to set the current through the LED display. LED brightness can be controlled by analog or digital means. The device can be programmed to use the internal code-B/HEX decoder to display numeric digits or to directly address each segment.

The AS1108 features an extremely low shutdown current of typically  $3\mu\text{A}$ , and an operational current of less than  $500\mu\text{A}$ . The number of digits can be programmed, the device can be reset by software, and an external clock is also supported. Additionally, segment blinking can be synchronized across multiple drivers.

The AS1108 provides several test modes for easy application debugging.

The device is available in a SOIC 20-pin package.

### 2 Key Features

- 10MHz SPI-, QSPI-, Microwire-Compatible Serial I/O
- Individual LED Segment Control
- Segment Blinking Control (can be synchronized across multiple drivers)
- Hexadecimal- or BCD-Code/No-Decode Digit Selection
- $3\mu\text{A}$  Low-Power Shutdown Current (typ; data retained)
- Extremely Low Operating Current  $0.5\text{mA}$  in Open-Loop
- Digital and Analog Brightness Control
- Display Blanked on Power-Up
- Drive Common-Cathode LED Displays
- Supply Voltage Range:  $+2.7$  to  $+5.5\text{V}$
- Software Reset
- Optional External Clock
- SOIC 20-pin package

### 3 Applications

The AS1108 is ideal for bar-graph displays, instrument-panel meters, LED matrix displays, dot matrix displays, set-top boxes, white goods, professional audio equipment, medical equipment, industrial controllers and panel meters.

Figure 1. AS1108 - Typical Application Diagram

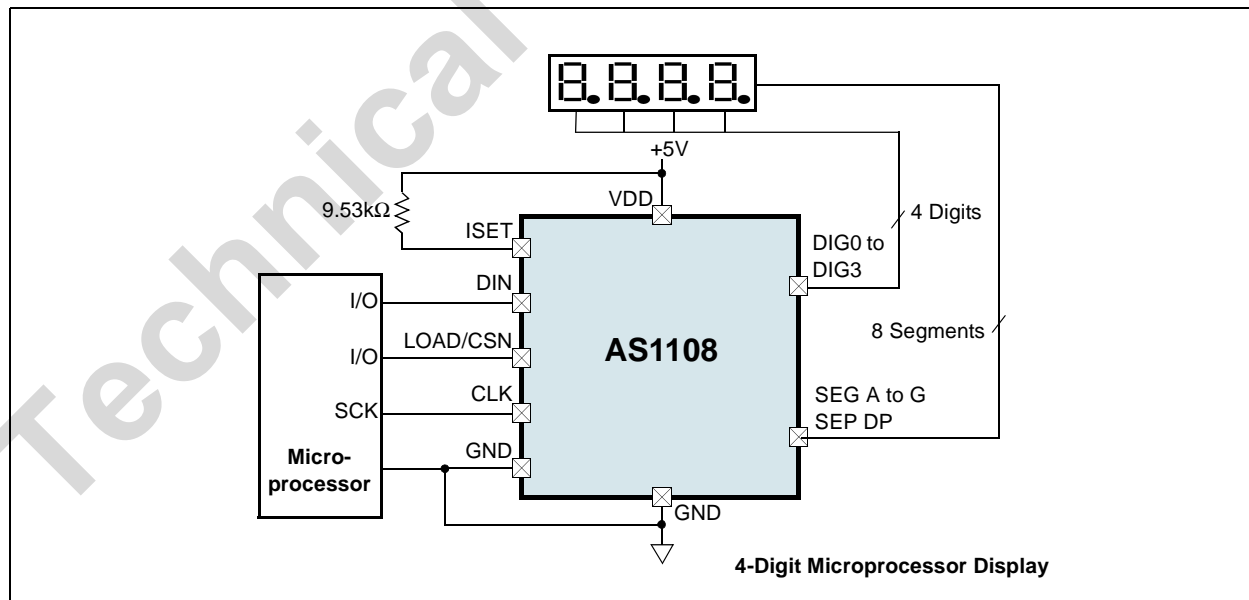

## 4 Pinout

### Pin Assignments

Figure 2. Pin Assignments (Top View)

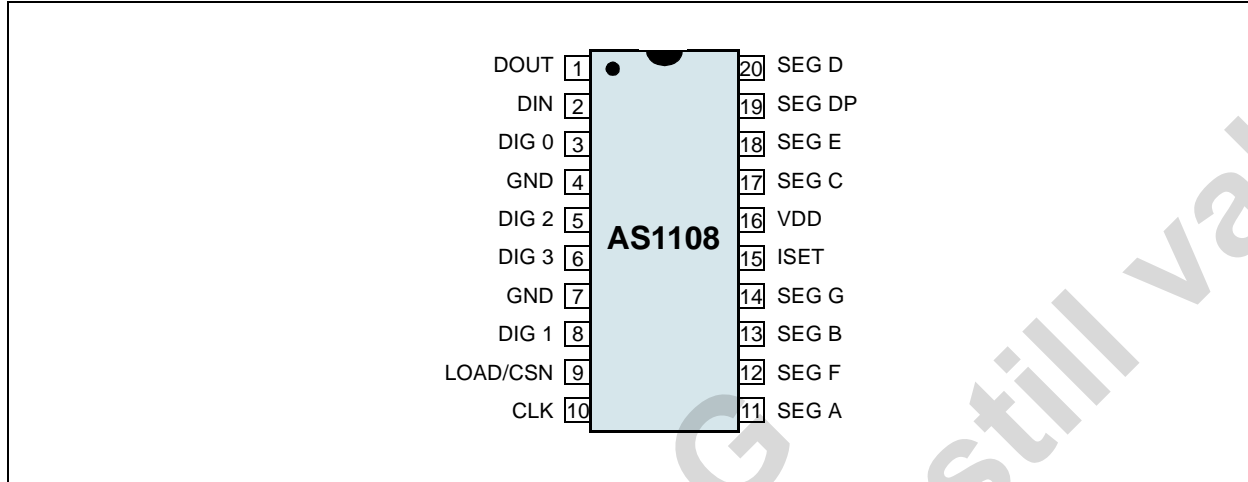

### Pin Descriptions

Table 1. Pin Descriptions

Pin Number	Pin Name	Description
1	DOUT	<b>Serial-Data Output.</b> The data into pin DIN is valid at pin DOUT 16.5 clock cycles later. This pin is used to daisy-chain several AS1108 devices and is never high-impedance.
2	DIN	<b>Serial-Data Input.</b> Data is loaded into the internal 16-bit shift register on the rising edge of pin CLK.
3, 5, 6, 8	DIG 0: DIG 3	<b>Digit Drive Lines.</b> 4 four-digit drive lines that sink current from the display common cathode. The AS1108 pulls the digit outputs to VDD when turned off.
4, 7	GND	<b>Ground.</b> Both GND pins must be connected.
9	LOAD/CSN	<b>Load-Data Input.</b> The last 16 bits of serial data are latched on the rising edge of this pin. <b>Chip-Select Input (AS1108 SPI-enabled only).</b> Serial data is loaded into the shift register while this pin is low. The last 16 bits of serial data are latched on the rising edge of this pin.
10	CLK	<b>Serial-Clock Input.</b> 10MHz maximum rate. Data is shifted into the internal shift register on the rising edge of this pin. Data is clocked out of DOUT on the falling edge of this pin. On the AS1108 SPI-enabled, the CLK input is active only while pin LOAD/CSN is low.
11, 12, 13, 14, 17, 18, 19, 20	SEG A: SEG G, SEG DP	<b>Seven Segment and Decimal Point Drive Lines.</b> 8 seven-segment drives and decimal point drive that source current to the display. When a segment driver is turned off it is pulled to GND.
15	ISET	<b>Set Segment Current.</b> Connect to VDD through RSET to set the peak segment current (see Selecting RSET Resistor Value and Using External Drivers on page 14).
16	VDD	<b>Positive Supply Voltage.</b> Connect to +2.7 to +5.5V supply.

## 5 Absolute Maximum Ratings

Stresses beyond those listed in Table 2 may cause permanent damage to the device. These are stress ratings only, and functional operation of the device at these or any other conditions beyond those indicated in Section 6 Electrical Characteristics on page 4 is not implied. Exposure to absolute maximum rating conditions for extended periods may affect device reliability.

Table 2. Absolute Maximum Ratings

Parameter	Min	Max	Units	Notes
<b>Electrical Parameters</b>				
VDD to GND	-0.3	7	V	
All other pins to GND	-0.3	VDD + 0.3 (max 7V)	V	
<b>Current</b>				
DIG 0:DIG 3 Sink Current		500	mA	
SEG A:SEG G, SEG DP		100	mA	
Latch-Up Immunity		±200	mA	All pins except AS1108 pin 11: ±180 mA Norm: JEDEC 78
<b>Electrostatic Discharge</b>				
Digital outputs		1000	V	Norm: MIL 883 E method 3015
All other pins		1000	V	
<b>Continuous Power Dissipation (TA = +85°C)</b>				
Wide SOIC		941	mW	Derate 11.8mW/°C above +70°C
<b>Temperature Ranges and Storage Conditions</b>				
Storage Temperature Range	-55	+150	°C	
Package Body Temperature (Wide SOIC)		+260	°C	The reflow peak soldering temperature (body temperature) specified is in accordance with IPC/JEDEC J-STD-020 "Moisture/Reflow Sensitivity Classification for Non-Hermetic Solid State Surface Mount Devices". The lead finish for Pb-free leaded packages is matte tin (100% Sn).
Humidity	5	85	%	Non-condensing
Moisture Sensitive Level		3		Represents a max. floor life time of 168h

## 6 Electrical Characteristics

$V_{DD} = 2.7V$  to  $5.5V$ ,  $R_{SET} = 9.53k\Omega \pm 1\%$ ,  $T_{AMB} = T_{MIN}$  to  $T_{MAX}$  (unless otherwise specified). All limits are guaranteed. The parameters with min and max values are guaranteed with production tests or SQC (Statistical Qualification Control) methods.

Table 3. Electrical Characteristics

Parameter	Symbol	Conditions	Min	Typ	Max	Unit
Operating Temperature Range	$T_{AMB}$		0		+70	°C
Operating Supply Voltage	$V_{DD}$		2.7	5.0	5.5	V
Shutdown Supply Current	$I_{DDSD}$	All digital inputs at $V_{DD}$ or GND, $T_{AMB} = +25^{\circ}C$			10	$\mu A$
Operating Supply Current	$I_{DD}$	$R_{SET} =$ open circuit.			1	mA
		All segments and decimal point on; $I_{SEG} = -40mA$ .		330		
Display Scan Rate	$f_{OSC}$	4 digits scanned	1000	1600	2600	Hz
Digit Drive Sink Current	$I_{DIGIT}$	$V_{OUT} = 0.65V$	320			mA
Segment Drive Source Current	$I_{SEG}$	$V_{DD} = 5.0V$ , $V_{OUT} = (V_{DD} - 1V)$	-30	-40	-45	mA
Segment Drive Current Matching	$\Delta I_{SEG}$			3.0		%
Digit Drive Source Current	$I_{DIGIT}$	Digit off, $V_{DIGIT} = (V_{DD} - 0.3V)$	-2			mA
Segment Drive Sink Current	$I_{SEG}$	Segment off, $V_{SEG} = 0.3V$	5			mA
Slow Segment Blink Period (ON phase, Internal Oscillator)	$t_{SLOWBLINK}$		0.64	1	1.65	s
Fast Segment Blink Period (ON phase, Internal Oscillator)	$t_{FASTBLINK}$		0.32	0.5	0.83	s
Fast or Slow Segment Blink Duty Cycle (Guaranteed by design)			49.9	50	50.1	%

Table 4. Logic Inputs/Outputs Characteristics

Parameter	Symbol	Conditions	Min	Typ	Max	Unit
Input Current DIN, CLK, LOAD/CSN	$I_{IH}$ , $I_{IL}$	$V_{IN} = 0V$ or $V_{DD}$	-1		1	$\mu A$
Logic High Input Voltage	$V_{IH}$		$0.7 \times V_{DD}$			V
Logic Low Input Voltage	$V_{IL}$	$V_{DD} = 5.0V \pm 10\%$			0.8	V
		$V_{DD} = 3.0V \pm 10\%$			0.6	
Output High Voltage	$V_{OH}$	DOUT, $I_{SOURCE} = -1mA$ , $V_{DD} = 5.0V \pm 10\%$	$V_{DD} - 1$			V
		DOUT, $I_{SOURCE} = -1mA$ , $V_{DD} = 3.0V \pm 10\%$	$V_{DD} - 0.5$			
Output Low Voltage	$V_{OL}$	DOUT, $I_{SINK} = 1.6mA$			0.4	V
Hysteresis Voltage	$\Delta V_I$	DIN, CLK, LOAD/CSN		1		V

Table 5. Timing Characteristics (see Figure 10 on page 8)

Parameter	Symbol	Conditions	Min	Typ	Max	Unit
CLK Clock Period	tCP		100			ns
CLK Pulse Width High	tCH		50			ns
CLK Pulse Width Low	tCL		50			ns
CSM Fall-to-CLK Rise Setup Time (AS1108 SPI-programmed)	tCSS		25			ns
CLK Rise-to -LOAD/CSN Rise Hold Time	tCSH		0			ns
DIN Setup Time	tDS		25			ns
DIN Hold Time	tDH		0			ns
Output Data Propagation Delay	tDO	CLOAD = 50pF			25	ns
LOAD Rising Edge-to-Next Clock Rising Edge	tLDCK		50			ns
Minimum LOAD/CSN Pulse High	tCSW		50			ns
Data-to-Segment Delay	tDSPD				2.25	ms

## 7 Typical Operating Characteristics

$V_{DD} = 5V$ ,  $R_{SET} = 9.53k\Omega$ ,  $T_{AMB} = 25^\circ C$  (unless otherwise specified).

Figure 3. Scan Frequency vs. Temperature

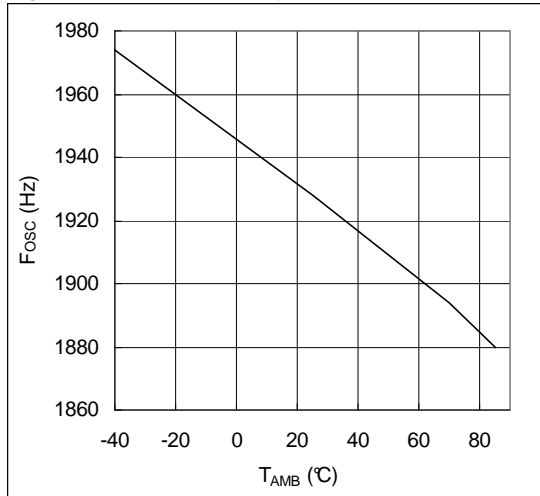

Figure 4. Scan Frequency vs.  $V_{DD}$

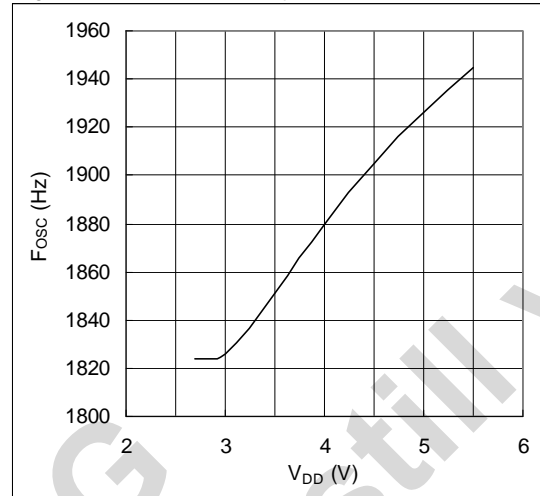

Figure 5.  $I_{SEG}$  vs. Temperature

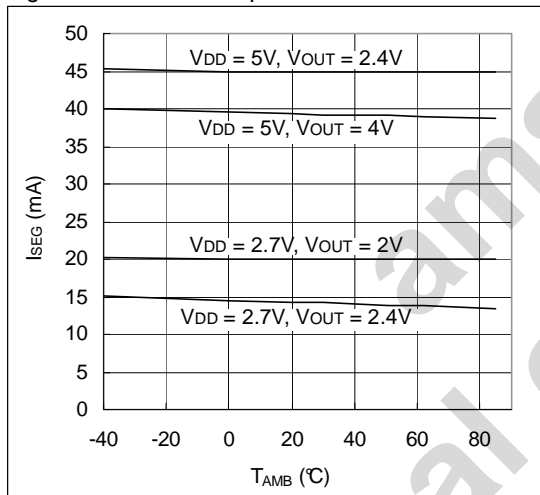

Figure 6.  $I_{SEG}$  vs.  $V_{DD}$

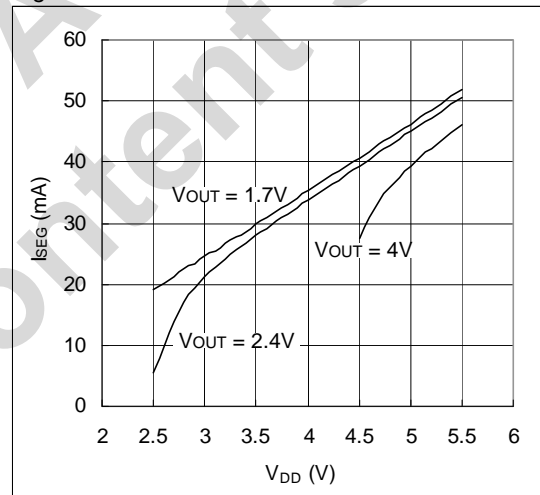

Figure 7.  $I_{SEG}$  vs.  $V_{OUT}$

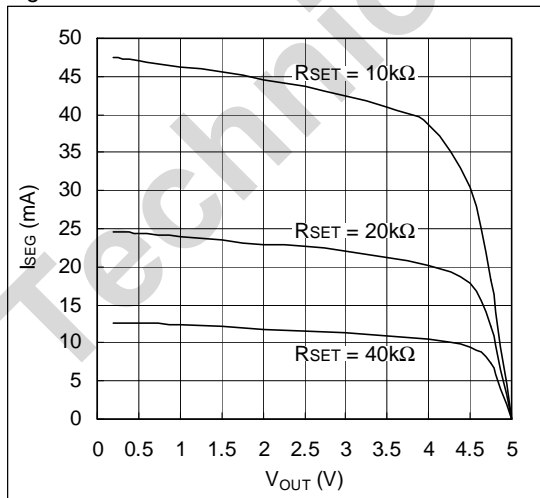

Figure 8.  $I_{SEG}$  vs.  $V_{OUT}$

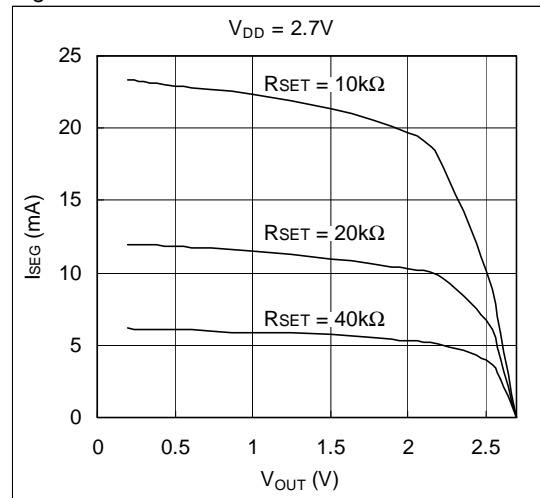
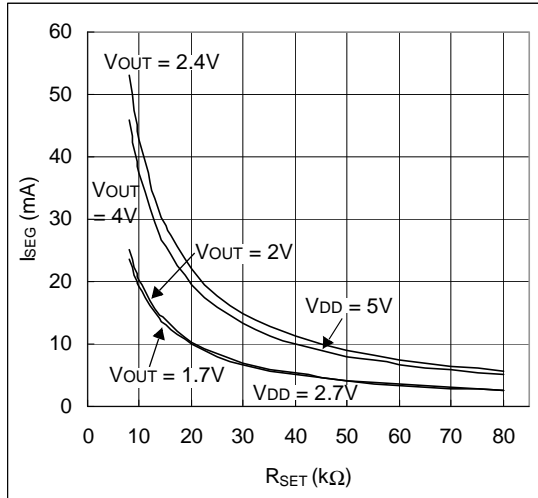

Figure 9.  $I_{SEG}$  vs.  $R_{SET}$ 

ams AG  
Technical content still valid



## 8 Detailed Description

### Serial-Addressing Format

Programming the AS1108 is accomplished by writing to the device's internal registers (see Digit- and Control-Registers on page 9) via the 4-wire serial interface. A programming sequence consists of 16-bit packages as depicted in Table 6.

The data is shifted into the internal 16-bit register with the rising edge of the CLK signal. With the rising edge of the LOAD/CSN signal the data is latched into a digit- or control-register. The LOAD/CSN signal must go high after the 16th rising clock edge.

The LOAD/CSN signal can also come later but this must happen just before the next rising edge of CLK, otherwise the data will be lost. The contents of the internal shift register are applied 16.5 clock cycles later to pin DOUT. The data is clocked out at the falling edge of CLK.

The first 4 bits (D15:D12) are "don't care" settings, bits D11:D8 contain the register address, and bits D7:D0 contain the data. The first bit is D15, the most significant bit (MSB). The exact timing is shown in Figure 10.

Table 6. 16-Bit Serial Data Format

D15	D14	D13	D12	D11	D10	D9	D8	D7	D6	D5	D4	D3	D2	D1	D0	
X	X	X	X	Register Address (see Table 7)				MSB				Data				LSB

### Initial Power-Up

On initial power-up, the AS1108 registers are reset to their default values, the display is blanked, and the device goes into shutdown mode. All registers should be programmed for normal operation at this time.

**Note:** The default settings enable only scanning of one digit; the internal decoder is disabled and the Intensity Control Register (see page 12) is set to the minimum values.

Figure 10. Interface Timing

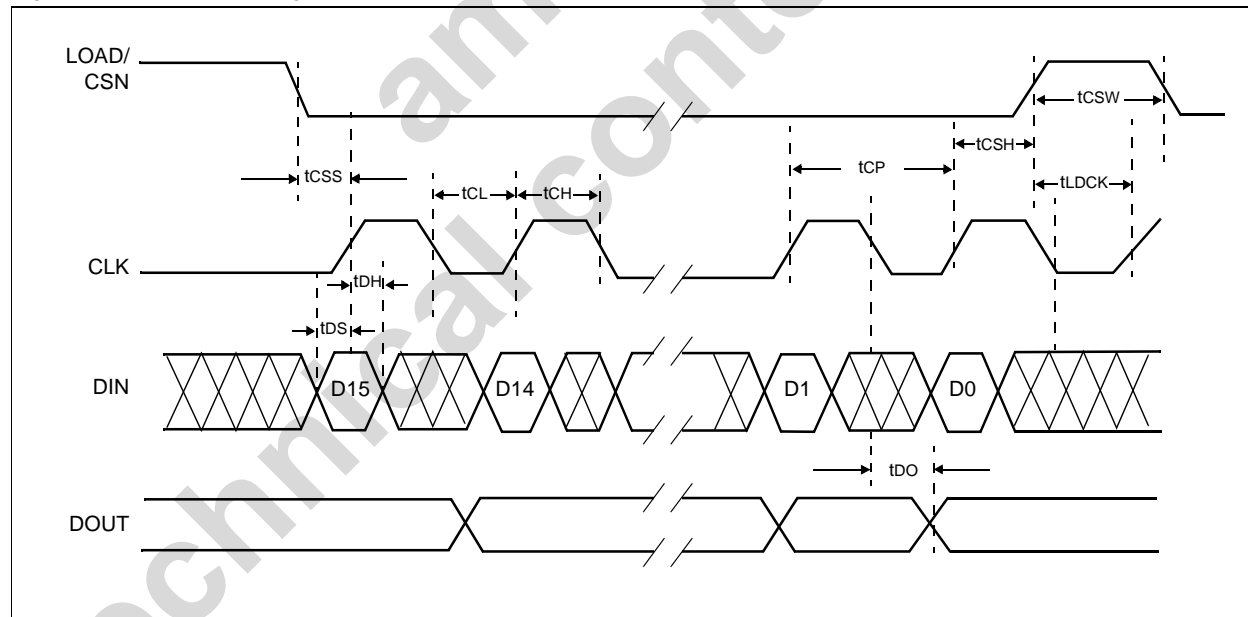

## Shutdown Mode

The AS1108 features a shutdown mode, consuming only 10µA (max) current. Shutdown mode is entered via a write to the Shutdown Register (see Table 8). At that point, all segment current sources are pulled to ground and all digit drivers are connected to V<sub>DD</sub>, so that all segments are blanked.

**Note:** During shutdown mode the Digit-Registers maintain their data.

Shutdown mode can either be used as a means to reduce power consumption or for generating a flashing display (repeatedly entering and leaving shutdown mode). For minimum supply current in shutdown mode, logic input should be at GND or V<sub>DD</sub> (CMOS logic level).

The device needs typically 250µs to exit shutdown mode, and during shutdown mode the AS1108 is fully programmable. Only the display test mode (see page 11) overrides shutdown mode.

When entering or leaving shutdown mode, the Feature Register is reset to its default values (all 0s) when Shutdown Register bit D7 (page 10) = 0. When bit D7 = 1, the Feature Register is left unchanged when entering or leaving shutdown mode.

**Note:** If the AS1108 is used with an external clock, Shutdown Register bit D7 should be set to 1 when writing to the Shutdown Register.

## Digit- and Control-Registers

The AS1108 contains four Digit-Registers and six control-registers, which are listed in Table 7. All registers are selected using a 4-bit address word, and communication is done via the serial interface.

- Digit Registers – These registers are realized with an on-chip 32-bit memory. Each digit can be controlled directly without rewriting the whole register contents.
- Control Registers – These registers consist of decode mode, display intensity, number of scanned digits, shutdown, display test and features selection registers.

Table 7. Register Address Map

Register	HEX Code	Address					Page
		D15:D12	D11	D10	D9	D8	
No-Op	0xX0	X	0	0	0	0	13
Digit 0	0xX1	X	0	0	0	1	N/A
Digit 1	0xX2	X	0	0	1	0	N/A
Digit 2	0xX3	X	0	0	1	1	N/A
Digit 3	0xX4	X	0	1	0	0	N/A
Decode-Mode	0xX9	X	1	0	0	1	10
Intensity Control	0xXA	X	1	0	1	0	12
Scan Limit	0xXB	X	1	0	1	1	12
Shutdown	0xXC	X	1	1	0	0	10
N/A	0xD	X	1	1	0	1	N/A
Feature	0xE	X	1	1	1	0	13
Display Test	0xF	X	1	1	1	1	11

### Shutdown Register (0xXC)

The Shutdown Register controls AS1108 shutdown mode (see Shutdown Mode on page 9).

Table 8. Shutdown Register Format (Address (HEX) = 0xXC))

Mode	HEX Code	Register Data							
		D7	D6	D5	D4	D3	D2	D1	D0
Shutdown Mode, Reset Feature Register to Default Settings	0x00	0	X	X	X	X	X	X	0
Shutdown Mode, Feature Register Unchanged	0x80	1	X	X	X	X	X	X	0
Normal Operation, Reset Feature Register to Default Settings	0x01	0	X	X	X	X	X	X	1
Normal Operation, Feature Register Unchanged	0x81	1	X	X	X	X	X	X	1

### Decode Enable Register (0xX9)

The Decode Enable Register sets the decode mode. BCD/HEX decoding (either BCD code – characters 0:9, E, H, L, P, and -, or HEX code – characters 0:9 and A:F) is selected by bit D2 (page 13) of the Feature Register. The Decode Enable Register is used to select the decode mode or no-decode for each digit. Each bit in the Decode Enable Register corresponds to its respective display digit (i.e., bit D0 corresponds to digit 0, bit D1 corresponds to digit 1 and so on). Table 10 lists some examples of the possible settings for the Decode Enable Register bits.

**Note:** A logic high enables decoding and a logic low bypasses the decoder altogether.

When decode mode is used, the decoder looks only at the lower-nibble (bits D3:D0) of the data in the Digit-Registers, disregarding bits D6:D4. Bit D7 sets the decimal point (SEG DP) independent of the decoder and is positive logic (bit D7 = 1 turns the decimal point on). Table 10 lists the code-B font; Table 11 lists the HEX font.

When no-decode mode is selected, data bits D7:D0 of the Digit-Registers correspond to the segment lines of the AS1108. Table 12 shows the 1:1 pairing of each data bit and the appropriate segment line.

Table 9. Decode Enable Register Format (Address (HEX) = 0xX9))

Decode Mode	HEX Code	Register Data							
		D7	D6	D5	D4	D3	D2	D1	D0
No decode for digits 3:0	0x00	X	X	X	X	0	0	0	0
Code-B/HEX decode for digit 0. No decode for digits 3:1	0x01	X	X	X	X	0	0	0	1
Code-B/HEX decode for digits 3:0	0xFF	X	X	X	X	1	1	1	1

Figure 11. Standard 7-Segment LED Intensity Control and Inter-Digit Blanking

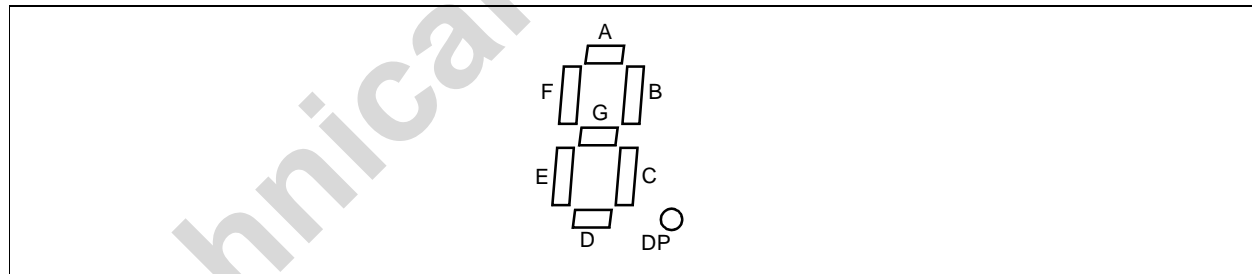

Table 10. Code-B Font

7-Segment Character	Register Data							On Segments = 1						
	D7 <sup>†</sup>	D6:D4	D3	D2	D1	D0	DP <sup>†</sup>	A	B	C	D	E	F	G
0		X	0	0	0	0		1	1	1	1	1	1	0
1		X	0	0	0	1		0	1	1	0	0	0	0
2		X	0	0	1	0		1	1	0	1	1	0	1
3		X	0	0	1	1		1	1	1	1	0	0	1
4		X	0	1	0	0		0	1	1	0	0	1	1
5		X	0	1	0	1		1	0	1	1	0	1	1

Table 10. Code-B Font (Continued)

7-Segment Character	Register Data							On Segments = 1						
	D7 <sup>†</sup>	D6:D4	D3	D2	D1	D0	DP <sup>†</sup>	A	B	C	D	E	F	G
6		X	0	1	1	0		1	0	1	1	1	1	1
7		X	0	1	1	1		1	1	1	0	0	0	0
8		X	1	0	0	0		1	1	1	1	1	1	1
9		X	1	0	0	1		1	1	1	1	0	1	1
-		X	1	0	1	0		0	0	0	0	0	0	1
E		X	1	0	1	1		1	0	0	1	1	1	1
H		X	1	1	0	0		0	1	1	0	1	1	1
L		X	1	1	0	1		0	0	0	1	1	1	0
P		X	1	1	1	0		1	1	0	0	1	1	1
Blank		X	1	1	1	1		0	0	0	0	0	0	0

<sup>†</sup> The decimal point is enabled by setting bit D7 = 1.

Table 11. HEX Font

7-Segment Character	Register Data							On Segments = 1						
	D7 <sup>†</sup>	D6:D4	D3	D2	D1	D0	DP <sup>†</sup>	A	B	C	D	E	F	G
0		X	0	0	0	0		1	1	1	1	1	1	0
1		X	0	0	0	1		0	1	1	0	0	0	0
2		X	0	0	1	0		1	1	0	1	1	0	1
3		X	0	0	1	1		1	1	1	1	0	0	1
4		X	0	1	0	0		0	1	1	0	0	1	1
5		X	0	1	0	1		1	0	1	1	0	1	1
6		X	0	1	1	0		1	0	1	1	1	1	1
7		X	0	1	1	1		1	1	1	0	0	0	0
8		X	1	0	0	0		1	1	1	1	1	1	1
9		X	1	0	0	1		1	1	1	1	0	1	1
A		X	1	0	1	0		1	1	1	0	1	1	1
b		X	1	0	1	1		0	0	1	1	1	1	1
C		X	1	1	0	0		1	0	0	1	1	1	0
d		X	1	1	0	1		0	1	1	1	1	0	1
E		X	1	1	1	0		1	0	0	1	1	1	1
F		X	1	1	1	1		1	0	0	0	1	1	1

<sup>†</sup> The decimal point is enabled by setting bit D7 = 1.

Table 12. No-Decode Mode Data Bits and Corresponding Segment Lines

	D7	D6	D5	D4	D3	D2	D1	D0
Corresponding Segment Line	DP	A	B	C	D	E	F	G

### Display-Test Register (0xXF)

The AS1108 can operate in two modes: normal mode and display test mode. In display test mode all LEDs are switched on at maximum brightness (duty cycle is 15/16). The device remains in display-test mode until the Display-Test Register is set for normal operation.

**Note:** All settings of the Digit- and Control-Registers are maintained.

Table 13. Display-Test Register Format (Address (HEX) = 0xXF)

Mode	Register Data							
	D7	D6	D5	D4	D3	D2	D1	D0
Normal Operation	X	X	X	X	X	X	X	0
Display Test Mode	X	X	X	X	X	X	X	1

### Intensity Control Register (0xA)

The brightness of the display can be controlled by digital means using the Intensity Control Register and by analog means using RSET (see Selecting RSET Resistor Value and Using External Drivers on page 14).

Display brightness is controlled by an integrated pulse-width modulator which is controlled by the lower-nibble of the Intensity Control Register. The modulator scales the average segment-current in 16 steps from a maximum of 31/32 down to 1/32 of the peak current set by RSET.

Table 14. Intensity Register Format (Address (HEX) = 0xA)

Duty Cycle AS1108	HEX Code	Register Data							
		D7	D6	D5	D4	D3	D2	D1	D0
1/32 (min on)	0x0	X	X	X	X	0	0	0	0
3/32	0x1	X	X	X	X	0	0	0	1
5/32	0x2	X	X	X	X	0	0	1	0
7/32	0x3	X	X	X	X	0	0	1	1
9/32	0x4	X	X	X	X	0	1	0	0
11/32	0x5	X	X	X	X	0	1	0	1
13/32	0x6	X	X	X	X	0	1	1	0
15/32	0x7	X	X	X	X	0	1	1	1
17/32	0x8	X	X	X	X	1	0	0	0
19/32	0x9	X	X	X	X	1	0	0	1
21/32	0xA	X	X	X	X	1	0	1	0
23/32	0xB	X	X	X	X	1	0	1	1
25/32	0xC	X	X	X	X	1	1	0	0
27/32	0xD	X	X	X	X	1	1	0	1
29/32	0xE	X	X	X	X	1	1	1	0
31/32 (max on)	0xF	X	X	X	X	1	1	1	1

### Scan-Limit Register (0xB)

The Scan-Limit Register controls which of the digits are to be displayed. When all 4 digits are to be displayed, the update frequency is typically 1600Hz. If the number of digits displayed is reduced, the update frequency is increased. The frequency can be calculated using  $8f_{OSC}/N$ , where N is the number of digits. Since the number of displayed digits influences the brightness, RSET should be adjusted accordingly. Table 16 lists the maximum allowed current when fewer than 4 digits are used.

**Note:** To avoid differences in brightness this register should not be used to blank parts of the display (leading zeros).

Table 15. Scan-Limit Register Format (Address (HEX) = 0xB)

Scan Limit	HEX Code	Register Data							
		D7	D6	D5	D4	D3	D2	D1	D0
Display digit 0 only (see Table 16)	0x0	X	X	X	X	X	0	0	0
Display digits 0:1 (see Table 16)	0x1	X	X	X	X	X	0	0	1
Display digits 0:2 (see Table 16)	0x2	X	X	X	X	X	0	1	0
Display digits 0:3	0x3	X	X	X	X	X	0	1	1

Table 16. Maximum Segment Current for 1-, 2-, or 3-Digit Displays

Number of Digits Displayed	Maximum Segment Current (mA)
1	10
2	20
3	30

### Feature Register (0xXE)

The Feature Register is used for switching the device into external clock mode, applying an external reset, selecting code-B or HEX decoding, enabling or disabling blinking, enabling or disabling the SPI-compatible interface, setting the blinking rate, and resetting the blink timing.

**Note:** At power-up the Feature Register is initialized to 0.

Table 17. Feature Register Summary

D7	D6	D5	D4	D3	D2	D1	D0
blink_start	sync	blink_freq_sel	blink_en	spi_en	decode_sel	reg_res	clk_en

Table 18. Feature Register Bit Descriptions (Address (HEX) = 0xXE)

Addr: 0xXE		Feature Register		Bit Description
		Enables and disables various device features.		
Bit	Bit Name	Default	Access	
D0	clk_en	0	R/W	External clock select. 0 = Internal oscillator is used for system clock. 1 = Pin CLK of the serial interface operates as system clock input.
D1	reg_res	0	R/W	Resets all control registers except the Feature Register. 0 = Reset Disabled. Normal operation. 1 = All control registers are reset to default state (except the Feature Register) identically after power-up. <b>Note:</b> The Digit Registers maintain their data.
D2	decode_sel	0	R/W	Selects display decoding. 0 = Enable Code-B decoding (see Table 10 on page 10). 1 = Enable HEX decoding (see Table 11 on page 11).
D3	spi_en	0	R/W	Enables the SPI-compatible interface. 0 = Disable SPI-compatible interface. 1 = Enable the SPI-compatible interface.
D4	blink_en	0	R/W	Enables blinking. 0 = Disable blinking. 1 = Enable blinking.
D5	blink_freq_sel	0	R/W	Sets blink with low frequency (with the internal oscillator enabled): 0 = Blink period typically is 1 second (0.5s on, 0.5s off). 1 = Blink period is 2 seconds (1s on, 1s off).
D6	sync	0	R/W	Synchronizes blinking on the rising edge of pin LOAD/CSN. The multiplex and blink timing counter is cleared on the rising edge of pin LOAD/CSN. By setting this bit in multiple AS1108 devices, the blink timing can be synchronized across all the devices.
D7	blink_start	0	R/W	Start Blinking with display enabled phase. When bit D4 (blink_en) is set, bit D7 determines how blinking starts. 0 = Blinking starts with the display turned off. 1 = Blinking starts with the display turned on.

### No-Op Register (0xX0)

The No-Op Register is used when multiple AS1108 devices are cascaded in order to support displays with more than 4 digits. The cascading must be done in such a way that all DOUT pins are connected to DIN of the next AS1108 (see Figure 12 on page 16). The LOAD/CSN and CLK signals are connected to all devices.

For example, if five devices are cascaded, in order to perform a write operation to the fifth device, the write-command must be followed by four no-operation commands. When the LOAD/CSN signal goes high, all shift registers are latched. The first four devices will receive no-operation commands and only the fifth device will receive the intended operation command, and subsequently update its register.

## 9 Typical Application

### Supply Bypassing and Wiring

In order to achieve optimal performance the AS1108 should be placed very close to the LED display to minimize effects of electromagnetic interference and wiring inductance.

Furthermore, a 10 $\mu$ F electrolytic and a 0.1 $\mu$ F ceramic capacitor should be connected between pins VDD and GND to avoid power supply ripple (see Figure 12 on page 16).

**Note:** Both GND pins must be connected to ground.

### Selecting R<sub>SET</sub> Resistor Value and Using External Drivers

Brightness of the display segments is controlled via R<sub>SET</sub>. The current that flows between VDD and ISET defines the current that flows through the LEDs.

Segment current is about 200 times the current in ISET. Typical values for R<sub>SET</sub> for different segment currents, operating voltages, and LED voltage drop (V<sub>LED</sub>) are given in Tables 19 - 23. The maximum current the AS1108 can drive is 40mA. If higher currents are needed, external drivers must be used, in which case it is no longer necessary that the device drive high currents.

In cases where the device drives only a few digits, Table 16 specifies the maximum currents, and R<sub>SET</sub> must be set accordingly.

**Note:** The display brightness can also be logically controlled (see Selecting R<sub>SET</sub> Resistor Value and Using External Drivers on page 14).

Table 19. R<sub>SET</sub> vs. Segment Current and LED Forward Voltage, V<sub>DD</sub> = 2.7V

I <sub>SEG</sub> (mA)	V <sub>LED</sub> (V)	
	1.5	2.0
40	5k $\Omega$	4.4k $\Omega$
30	6.9k $\Omega$	5.9k $\Omega$
20	10.7k $\Omega$	9.6k $\Omega$
10	22.2k $\Omega$	20.7k $\Omega$

Table 20. R<sub>SET</sub> vs. Segment Current and LED Forward Voltage, V<sub>DD</sub> = 3.3V

I <sub>SEG</sub> (mA)	V <sub>LED</sub> (V)		
	1.5	2.0	2.5
40	6.7k $\Omega$	6.4k $\Omega$	5.7k $\Omega$
30	9.1k $\Omega$	8.8k $\Omega$	8.1k $\Omega$
20	13.9k $\Omega$	13.3k $\Omega$	12.6k $\Omega$
10	28.8k $\Omega$	27.7k $\Omega$	26k $\Omega$

Table 21. R<sub>SET</sub> vs. Segment Current and LED Forward Voltage, V<sub>DD</sub> = 3.6V

I <sub>SEG</sub> (mA)	V <sub>LED</sub> (V)			
	1.5	2.0	2.5	3.0
40	7.5k $\Omega$	7.2k $\Omega$	6.6k $\Omega$	5.5k $\Omega$
30	10.18k $\Omega$	9.8k $\Omega$	9.2k $\Omega$	7.5k $\Omega$
20	15.6k $\Omega$	15k $\Omega$	14.3k $\Omega$	13k $\Omega$
10	31.9k $\Omega$	31k $\Omega$	29.5k $\Omega$	27.3k $\Omega$

Table 22. R<sub>SET</sub> vs. Segment Current and LED Forward Voltage, V<sub>DD</sub> = 4.0V

I <sub>SEG</sub> (mA)	V <sub>LED</sub> (V)				
	1.5	2.0	2.5	3.0	3.5
40	8.6k $\Omega$	8.3k $\Omega$	7.9k $\Omega$	7.6k $\Omega$	5.2k $\Omega$
30	11.6k $\Omega$	11.2k $\Omega$	10.8k $\Omega$	9.9k $\Omega$	7.8k $\Omega$

Table 22.  $R_{SET}$  vs. Segment Current and LED Forward Voltage,  $V_{DD} = 4.0V$  (Continued)

$I_{SEG}$ (mA)	$V_{LED}(V)$				
	1.5	2.0	2.5	3.0	3.5
20	17.7k $\Omega$	17.3k $\Omega$	16.6k $\Omega$	15.6k $\Omega$	13.6k $\Omega$
10	36.89k $\Omega$	35.7k $\Omega$	34.5k $\Omega$	32.5k $\Omega$	29.1k $\Omega$

Table 23.  $R_{SET}$  vs. Segment Current and LED Forward Voltage,  $V_{DD} = 5.0V$ 

$I_{SEG}$ (mA)	$V_{LED}(V)$					
	1.5	2.0	2.5	3.0	3.5	4.0
40	11.35k $\Omega$	11.12k $\Omega$	10.84k $\Omega$	10.49k $\Omega$	10.2k $\Omega$	9.9k $\Omega$
30	15.4k $\Omega$	15.1k $\Omega$	14.7k $\Omega$	14.4k $\Omega$	13.6k $\Omega$	13.1k $\Omega$
20	23.6k $\Omega$	23.1k $\Omega$	22.6k $\Omega$	22k $\Omega$	21.1k $\Omega$	20.2k $\Omega$
10	48.9k $\Omega$	47.8k $\Omega$	46.9k $\Omega$	45.4k $\Omega$	43.8k $\Omega$	42k $\Omega$

Table 24. Package Thermal Data

Package	Thermal Resistance ( $\Theta_{JA}$ )
20 Wide SOIC	+85 $^{\circ}C/W$



## 4x8 LED Dot Matrix Driver

The application example in Figure 12 shows the AS1108 as a 4x8 LED dot matrix driver.

The LED columns have common cathodes and are connected to the DIG0:3 outputs. The rows are connected to the segment drivers. Each of the 32 LEDs can be addressed separately. The columns are selected via the digits as listed in Table 7 on page 9.

The Decode Enable Register (see page 10) must be set to '00000000' as described in Table 9 on page 10. Single LEDs in a column can be addressed as described in Table 12 on page 11, where bit D0 corresponds to segment G and bit D7 corresponds to segment DP.

**Note:** For a multiple-digit dot matrix, multiple AS1108 devices must be cascaded.

Figure 12. Application Example as LED Dot Matrix Driver

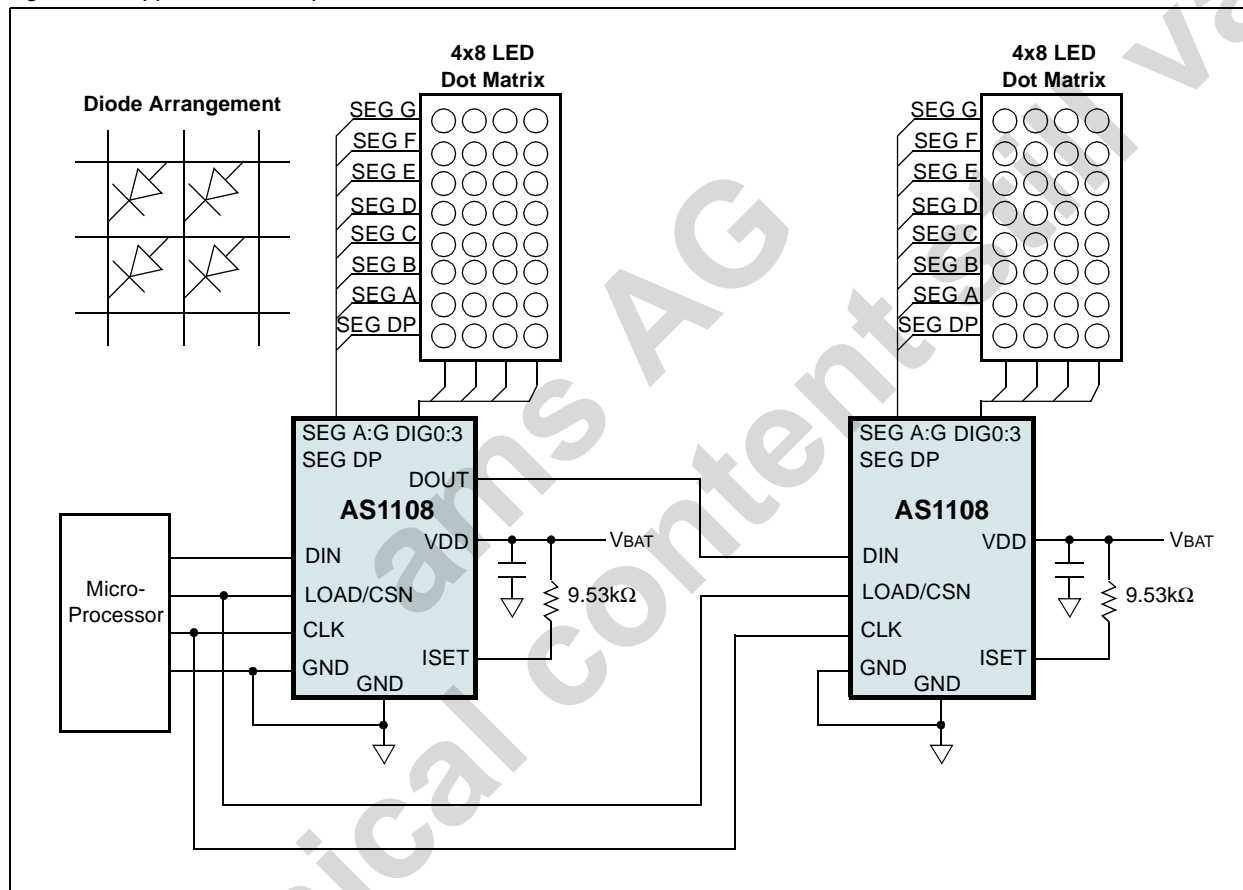

## Cascading Drivers

If more than 4 digits or 32 LEDs are needed, it is recommended to use the AS1106/AS1107, although several AS1108 devices can be cascaded.

The example in Figure 4 drives 2 dot matrix digits using a 4-wire microprocessor interface. All Scan-Limit Registers should be set to the same value so that one display will not appear brighter than the other.

For example, to display 6 digits, set both Scan-Limit Registers to display 3 digits so that both displays have a 1/3 duty cycle per digit. If 5 digits are needed, set both Scan-Limit Registers to display 3 digits and leave one digit unconnected. Otherwise, if one driver is set to display 3 digits and the other to display 2 digits one display will appear brighter because its duty cycle per digit will be 1/2 and the other display's duty cycle will be 1/3.

**Note:** Refer to No-Op Register (0xX0) on page 13 for additional information.

## 10 Package Drawings and Markings

Figure 13. SOIC 20-pin Marking



Table 25. Packaging Code YYWWRZZ

YY	WW	Q	ZZ
last two digits of the current year	manufacturing week	plant identifier	free choice / traceability code

Figure 14. SOIC 20-pin Package

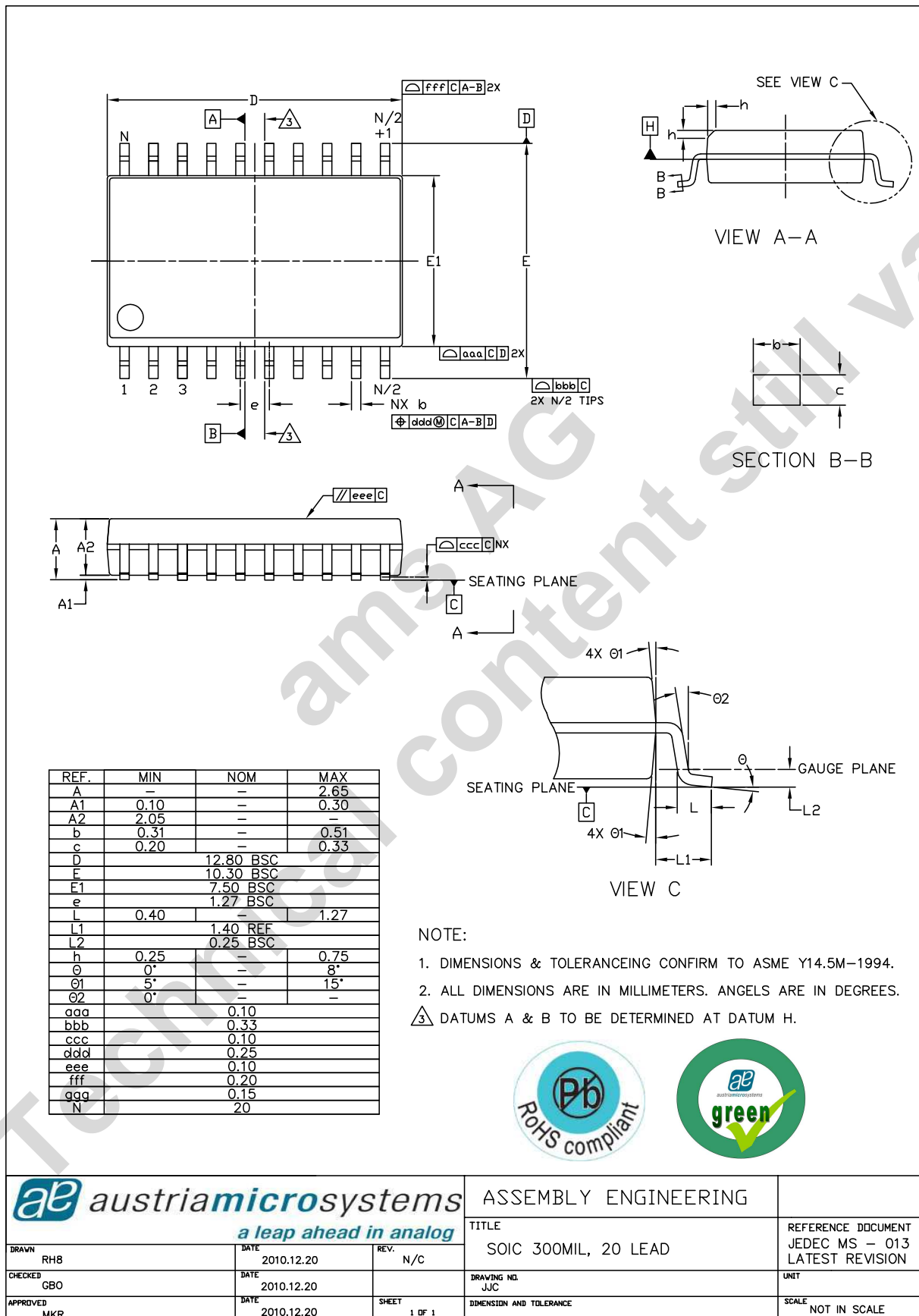

## 11 Ordering Information

The AS1108 is available as the standard products shown in Table 26.

Table 26. Ordering Information

Ordering Code	Marking	Description	Temperature Range	Delivery Form	Package
AS1108WL	AS1108WL	4-Digit LED Display Driver	0 to +70°C	Tubes	SOIC 20-pin
AS1108WL-T	AS1108WL	4-Digit LED Display Driver	0 to +70°C	Tape and Reel	SOIC 20-pin

**Note:** All products are RoHS compliant and austriamicrosystems green.

Buy our products or get free samples online at ICdirect: <http://www.austriamicrosystems.com/ICdirect>

Technical Support is found at <http://www.austriamicrosystems.com/Technical-Support>

For further information and requests, please contact us <mailto:sales@austriamicrosystems.com>  
or find your local distributor at <http://www.austriamicrosystems.com/distributor>

## Copyrights

Copyright © 1997-2012, austriamicrosystems AG, Tobelbaderstrasse 30, 8141 Unterpremstaetten, Austria-Europe. Trademarks Registered ®. All rights reserved. The material herein may not be reproduced, adapted, merged, translated, stored, or used without the prior written consent of the copyright owner.

All products and companies mentioned are trademarks or registered trademarks of their respective companies.

## Disclaimer

Devices sold by austriamicrosystems AG are covered by the warranty and patent indemnification provisions appearing in its Term of Sale. austriamicrosystems AG makes no warranty, express, statutory, implied, or by description regarding the information set forth herein or regarding the freedom of the described devices from patent infringement. austriamicrosystems AG reserves the right to change specifications and prices at any time and without notice. Therefore, prior to designing this product into a system, it is necessary to check with austriamicrosystems AG for current information. This product is intended for use in normal commercial applications. Applications requiring extended temperature range, unusual environmental requirements, or high reliability applications, such as military, medical life-support or life-sustaining equipment are specifically not recommended without additional processing by austriamicrosystems AG for each application. For shipments of less than 100 parts the manufacturing flow might show deviations from the standard production flow, such as test flow or test location.

The information furnished here by austriamicrosystems AG is believed to be correct and accurate. However, austriamicrosystems AG shall not be liable to recipient or any third party for any damages, including but not limited to personal injury, property damage, loss of profits, loss of use, interruption of business or indirect, special, incidental or consequential damages, of any kind, in connection with or arising out of the furnishing, performance or use of the technical data herein. No obligation or liability to recipient or any third party shall arise or flow out of austriamicrosystems AG rendering of technical or other services.



## Contact Information

### Headquarters

austriamicrosystems AG  
Tobelbaderstrasse 30  
A-8141 Unterpremstaetten, Austria

Tel: +43 (0) 3136 500 0  
Fax: +43 (0) 3136 525 01

For Sales Offices, Distributors and Representatives, please visit:

<http://www.austriamicrosystems.com/contact>

# Mouser Electronics

Authorized Distributor

Click to View Pricing, Inventory, Delivery & Lifecycle Information:

[ams:](#)

[AS1108WL-T](#)