



VCNL4000, VCNL4010, and VCNL4020 Demo Kit

INTRODUCTION

The VCNL40x0 sensors are fully integrated proximity and ambient light sensors. They combine an infrared emitter and PIN photodiode for proximity measurement, ambient light sensor, and signal processing IC in a single package with a 16 bit ADC. The devices provide ambient light sensing to support conventional backlight and display brightness auto-adjustment, and proximity sensing to minimize accidental touch input that can lead to call drops and camera launch for smart phones. With a range of up to 20 cm (7.9"), these stand-alone, single components greatly simplify the use and design-in of a proximity sensor in consumer and industrial applications because no mechanical barriers are required to optically isolate the emitter from the detector. The sensors feature a miniature leadless package (LLP) for surface mounting with a low profile of 0.75 mm for VCNL4000 and VCNL4010 and 0.83mm for VCNL4020 and VCNL3020. Through the standard I²C bus serial digital interface, they allow easy access to a "Proximity Signal" and "Light Intensity" measurement without complex calculations or programming. All versions besides the VCNL4000 offer a programmable interrupt function which may be used as a wake-up function for the microcontroller when a proximity event or ambient light change occurs; reducing processing overhead by eliminating the need for continuous polling.

For complete details on the VCNL40x0 please read "Designing VCNL40x0 into an Application"

www.vishay.com/doc?84138 for VCNL4010

www.vishay.com/doc?84136 for VCNL4020

www.vishay.com/doc?84139 for VCNL3020.

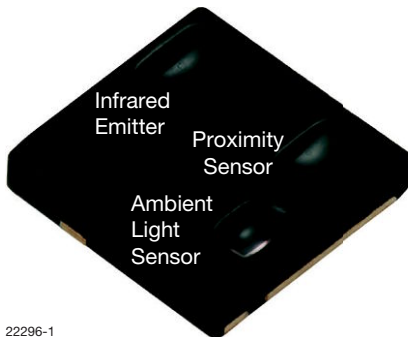

VCNL3020 is a 'Proximity-only' device without ambient light sensor. It has the same package size as the VCNL4020.

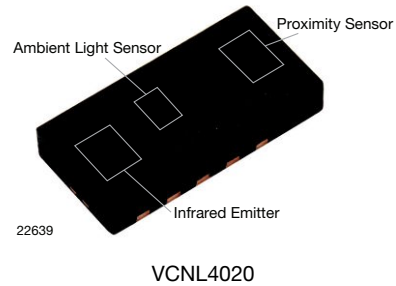

ESD WARNING

The VCNL40x0 are sensitive to electrostatic discharge. Please take necessary precautions when handling the sensor and kit. For further information please read [Assembly Instructions](#) and [Packaging and Ordering](#).

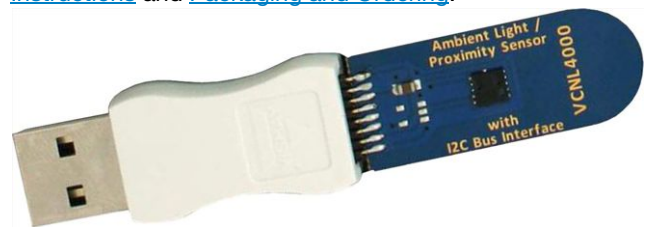

The VCNL4000 Demo Kit comes with a mini-CD containing the USB driver and software, a USB dongle and the VCNL4000 sensor board. This kit can be purchased from any of our catalog distributors. It serves as the base for the VCNL4010, VCNL4020, and VCNL3020 demo kits. For these sensors, please contact sensorstechsupport@vishay.com and we will send you the sensor board of your choice absolutely free. Software upgrades are available on our website at www.vishay.com/optoelectronics/moreinfo/vcnldemokit.

APPLICATION NOTE

VCNL4000, VCNL4010, and VCNL4020 Demo Kit



VCNL4010 Sensor Board



VCNL4020 Sensor Board

KIT COMPONENTS

There are three main components to the kit:

1. The blue sensor board on which is soldered the VCNL40x0, a decoupling capacitor, and the 2 x 8 pin connector
2. The USB dongle which takes care of delivering the needed I²C-Bus and supplies “clean” power to the sensor board
3. The development software found on the CD.

The sensor board can be plugged into the USB dongle in the up or down orientation. An indicator light will be illuminated when the sensor board is receiving power and connected to the development software. The CD also contains a Quick Start guide (www.vishay.com/doc?83396) menu and a software licensing agreement. Note that the licensing agreement must be saved in the C-drive root directory before the software will run:

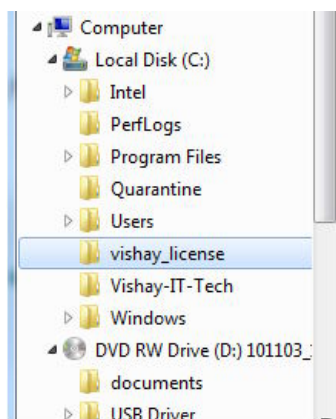

Vishay License in C:/Directory

VCNL4000 Development Software

After installing the software, run the following command: USB_Sensor_Kit_VCNL4000.exe or double click on the application software in the VCNL4000 Demo Kit folder. When executing the program, the Proximity Function screen is displayed. There are four tabbed files: Proximity Function, Ambient Light Function, Register Values, and Information VCNL4000

PROXIMITY FUNCTION

Proximity Mode

- select a single measurement or periodic measurement. The periodic measurement rates are set in the Measurement Speed window. The default setting is “single measurement (on demand)”. Selecting periodic measurement sets the ‘prox_od’ bit3 of the command register #0 (80h) to “1”. Compensation offset and IIR filtering is only available with periodic measurements. Screen shot 1.

Measurement Parameter

- sets the infrared emitter current. The infrared emitter current determines the effective range of the sensor; higher current will translate to longer sensing range. This feature can also be used to determine the impact of the cover or window on the sensing range. To compensate for the infrared light absorbed by the window, the current can be increased. The current can be set by either toggling up or down or by left clicking in the window and a current select bar will pop-up. The default setting is 100 mA.

Measurement Speed

- sets the delay time between two consecutive measurements when in periodic measurement mode. A delay time of “100” leads to about 10 measurements/s. Choosing “1” leads to more than 200 measurements/s which is the fastest rate for this demo tool.

Clear Display

Clears the upper and lower window graphs and resets the ‘Data#’ to zero. The Proximity Value field near the bottom of the screen is not cleared. This field will be updated with the next measurement.

Proximity Value

Changes the unit of measure for the proximity value. Click on the small blue letter on its left side. This letter indicates the selected format: b = binary, d = decimal, x = hexadecimal, o = octal and p stands for SI notation

Infinite Impulse Response (IIR) Filter

This low pass filter is activated with the ‘active’ button and shows an average of the measurement results. The average value can be changed from one to twenty by clicking on the toggle arrow where 1 corresponds to no averaging and 20 to strong averaging. When active the button will be red.



VCNL4000, VCNL4010, and VCNL4020 Demo Kit

Upper Window

Displays the entire 16-bit measured signal from 0 to 65 535 counts.

Lower Window

Displays only the active or dynamic range. The y-axis represents the number of counts and will change depending on the sensor reading.

Proximity Measurement

Click on the measure button to initiate a measurement.

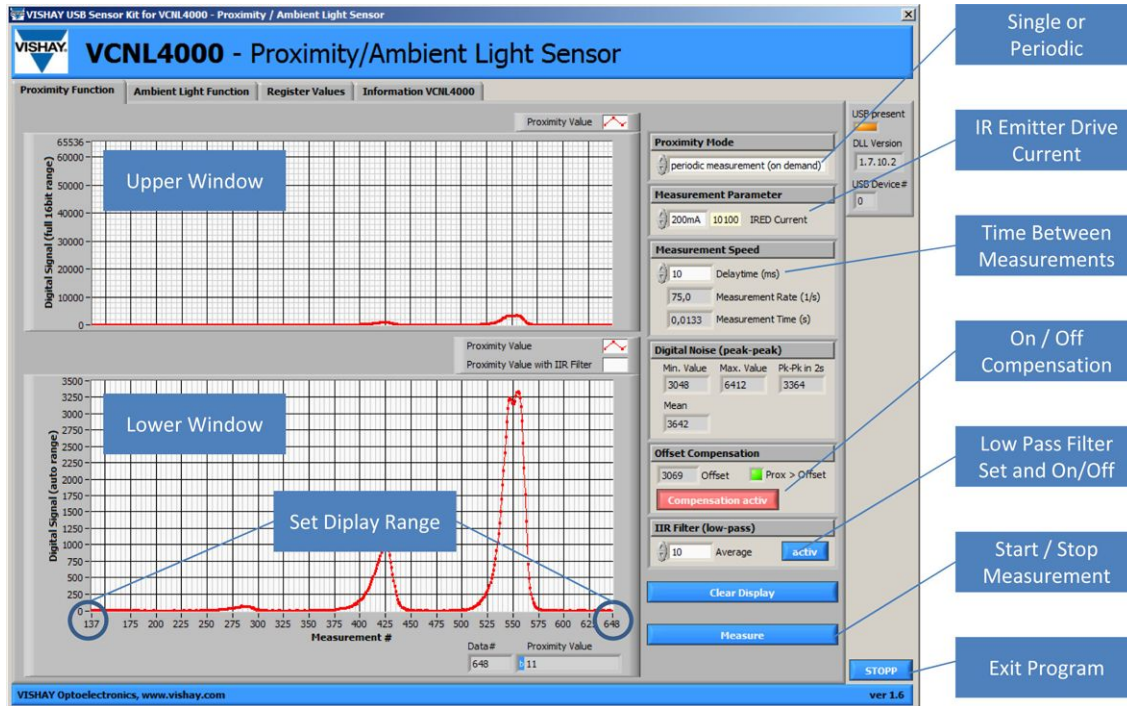

Screen Shot 1

Offset

Without an object in range, the upper window shows an offset of approximately 3000 counts. The lower windows shows the exact values. This offset is a result of optical crosstalk and digital noise. In an application where a window is placed over the top of the sensor, the offset value can be as high as 10 000 to 15 000 counts. For the kit, the offset value is calculated by averaging the last 2 seconds of counts. In a smart phone application the offset value should be subtracted from incoming proximity readings and the resultant used to determine object proximity.

Object with Range of 200 mm and 100 mm

Assuming the offset value is 3070 counts, at a range of 200 mm, the reflection from a hand results in an output count of 3090 counts. This is 20 counts higher than the offset or noise floor. At a range of 100 mm, the reflection of the object results in an output count of 3130 counts. This is 50 counts higher than the offset value. By clicking the "Compensate Offset" button, the software simulates this subtraction. When this function is active, the button will be red as in screen shot 1. With compensation offset active, the digital signal in the lower frame will display only the counts related to the reflected signal; effectively zeroing the offset. This is feature of the kit. In actual applications, the offset value should be subtracted to obtain actual proximity or ambient counts.

APPLICATION NOTE



VCNL4000, VCNL4010, and VCNL4020 Demo Kit

Object with Range of 10 mm and 5 mm

With compensation offset active, at a range of 10 mm, the reflection of the object results in an output count of approximately 1000 counts. At a range of 5 mm, the reflection of the object results in an output count of approximately 3000 counts. Again, with compensation offset active, the digital signal in the lower frame shows only the counts related to the reflected signal.

Display Range

Display a specific range of readings by entering a minimum reading number on the right side of the x-axis and the maximum reading number on the left side of the x-axis. Type over the existing displayed value. This feature is only available when measurements have stopped.

Register Values

The actual proximity value is available by selecting the Register Value tab. The high 16-bit value is stored in register#7 and the low value is stored in register #8. Register #7 equals 36 (dec) [00100100] and register #8 equals 33 (dec) [00100001]. See screen shot 2.

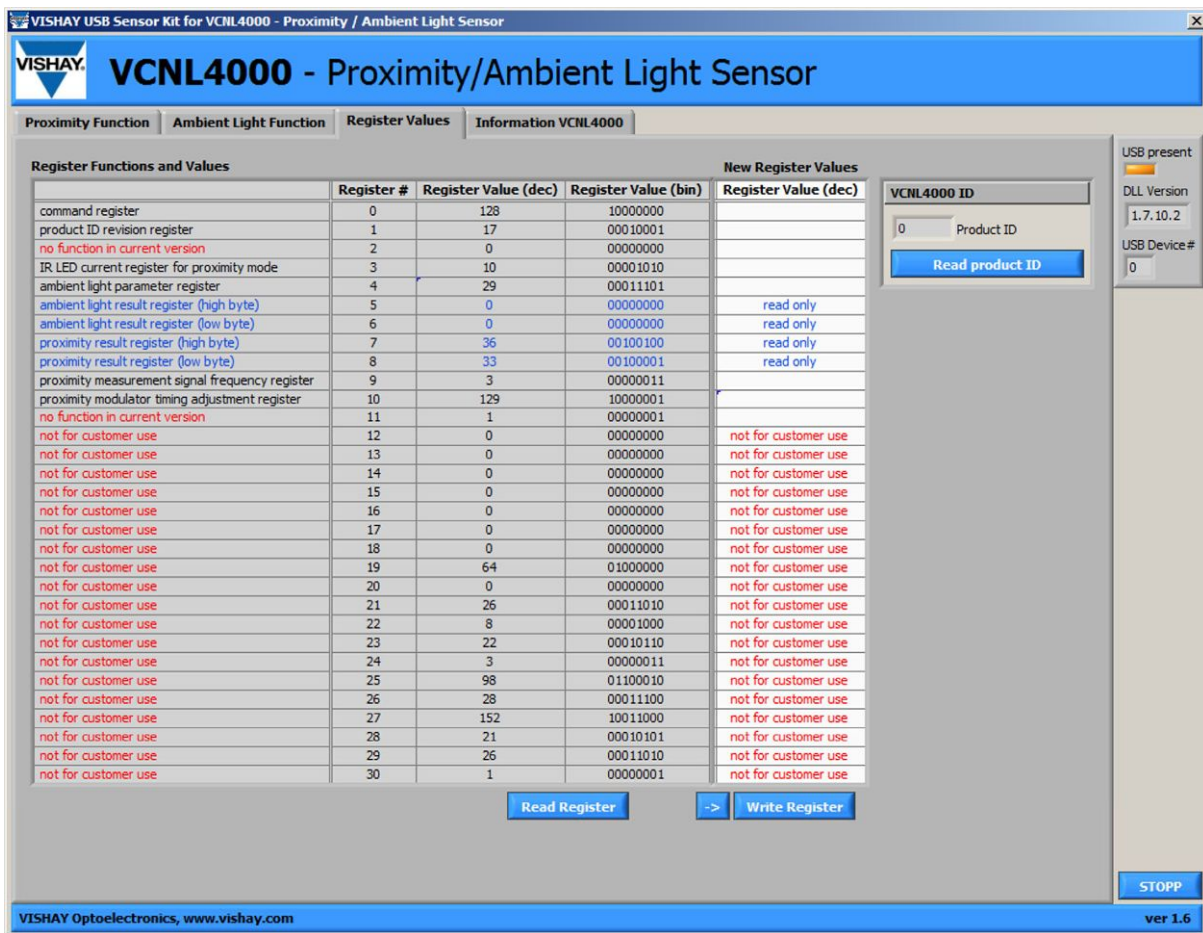

Screen Shot 2

FORMAT FEATURES - PROXIMITY

To Copy Graph

Right click within the upper or lower window and select "Copy Data".

To Change Line Color

Click inside the small white rectangle located between the upper and lower signal windows to change line colors, patterns and other features.

APPLICATION NOTE



VCNL4000, VCNL4010, and VCNL4020 Demo Kit

AMBIENT LIGHT FUNCTION

Ambient Mode

Select a single measurement or periodic measurement. The default setting is “single measurement (on demand)”. Click ‘Measure’ to execute the measure function. See screen shot 3.

Upper Window

The upper window displays the entire 16-bit measured signal from 0 to 65 535 counts.

Lower Window

The lower window displays only the active or dynamic range. The y-axis represents the number of counts and will change depending on the sensor reading.

Measurement Parameter

Defines the number of measurements used in the averaging function. Use the toggle button located under the “Sampled Values in 100 ms” title to scroll through available settings or click within the white value box

and a pull down menu opens displaying all available values. The advantage of this function is that disturbance from 50 Hz/60 Hz sources (100 Hz/120 Hz) is significantly reduced by averaging. The default setting is 128 which sets bit 0, bit 1 and bit 2 of register #4 to 7(dec) (111); translated, 2⁷ or 128 measurements within 100 ms. These 128 measurements are averaged and the result is then available within Ambient Light Result register #5 and #6.

Auto Offset

Compensates for temperature related drift of the ambient light measurements. With auto offset active, the offset value is measured before each ambient light measurement and subtracted automatically from the actual reading. The default setting is “Auto Offset” active. “Auto Offset” is bit 3 of Ambient Light Parameter Register #4 (84h).

Continuous Conversion

Allows for faster measurements. With this selected, single conversions are made in a much shorter time.

APPLICATION NOTE

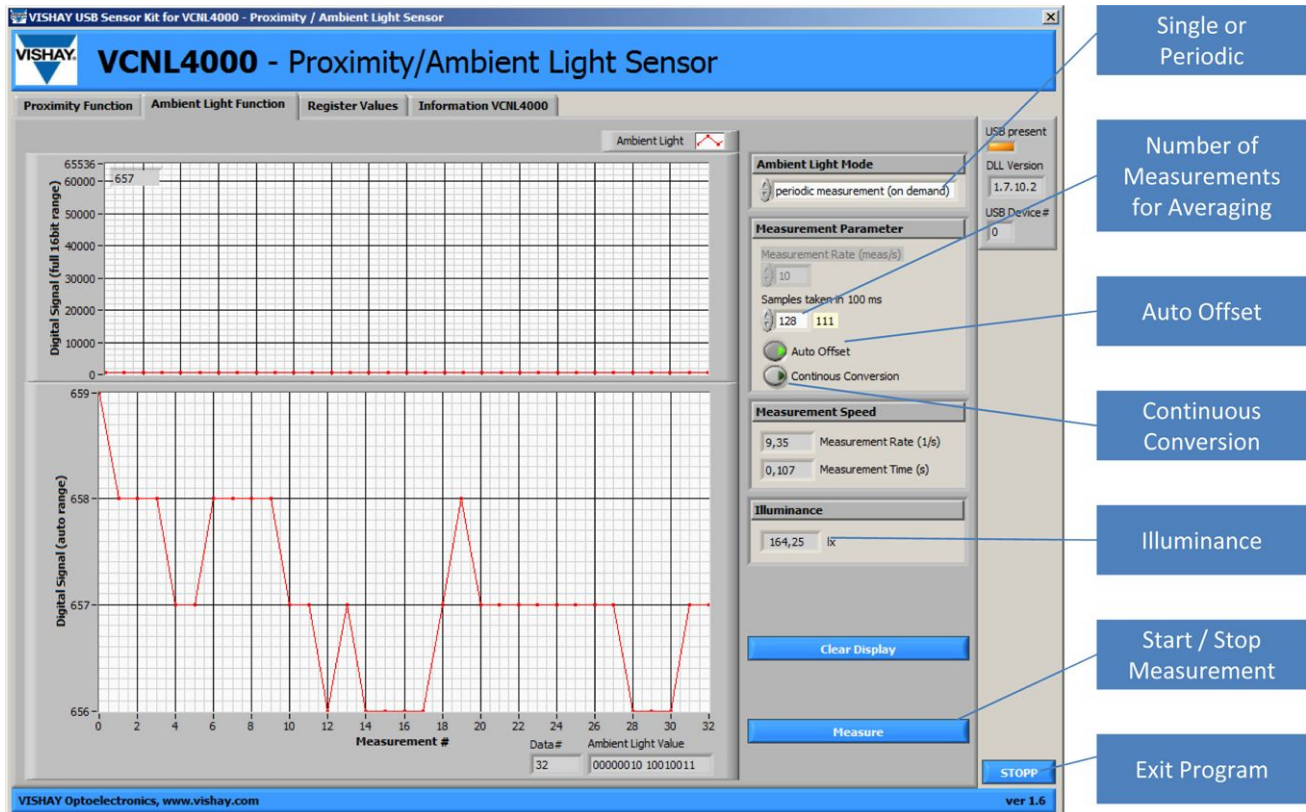

Screen Shot 3

VCNL4000, VCNL4010, and VCNL4020 Demo Kit

Clear Display

Clears the upper and lower window graphs and resets the 'Data#' to zero. The Proximity Value field near the bottom of the screen is not cleared. This field will be updated with the next measurement.

Ambient Light Value

Displays the ambient light value in binary form only.

Illuminance

Displays the ambient light level in lux. It is calculated by dividing the number of counts by four. For example, there are 615 counts which, when divided by four, results in 153.75.

Figure of Merit

The ideal ambient light sensor will produce exactly the same output (counts) for the same brightness regardless of the source of light. In reality, silicon-based ambient light sensors will produce slightly different readings for halogen (2856 K CIE illuminant A), incandescent, fluorescent and white LED sources. Figure 2 shows the average response for the VCNL4000 ambient light sensors for all the above light sources and graphs the number of counts versus lux value for each light source. The halogen lamp shows a factor of 5.1 for digital counts versus lux, the fluorescent lamp shows a factor of 3.2 and white LEDs shows a factor of 4.1. The average response is a factor of 4 counts per lux. As shown in Figure 1, a count of 1000 corresponds to 250 lx. This same count could be 200 lx for the halogen lamp or 310 lx for the fluorescent lamp. The overall tolerance for the VCNL4000 ambient light sensor for different light sources is - 22 % to + 24 %.

While the VCNL4000 has a sensitivity of 0.25 lux per count, the VCNL4010 and VCNL4020 have a sensitivity of 0.23 lux per count.

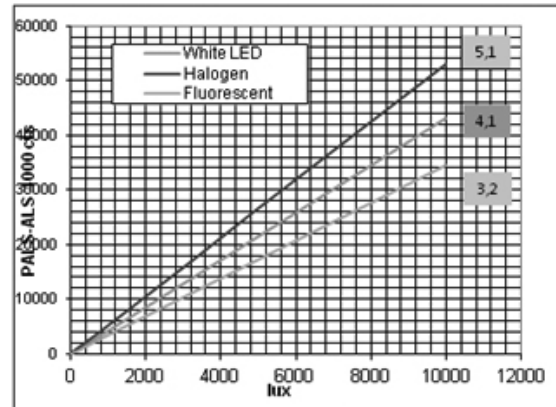

Fig. 2 - VCNL40x0 Measurements (cts) vs. Illuminance (lx)

VCNL4010 AND VCNL4020 DEMO KITS

The VCNL4010, VCNL4020, and VCNL3020 have two additional features compared to the VCNL4000: the first is an additional measurement mode called 'self timed mode' and the second is the interrupt feature. These two features required an upgrade in software.

For proximity, the 'selftimed mode' was added to 'single measurement' and 'periodic measurement' as a selection under the proximity mode section. The measurement parameter section has been retitled as proximity settings. Under this section the measurement rate selection window was added. Rather than setting a delay time that was converted to a rate, users can actually select the measurement rate. The measurement speed and digital noise title headers were eliminated but the data under these sections is still displayed in the new software. All other features are unchanged for proximity. See screen shot 4.

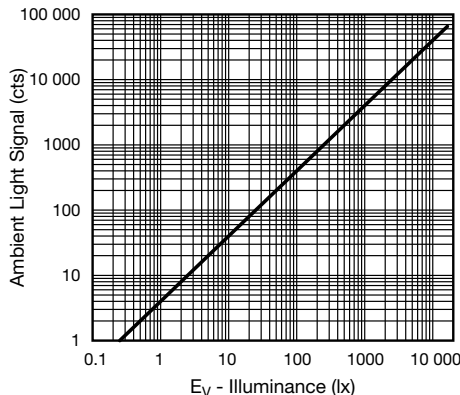
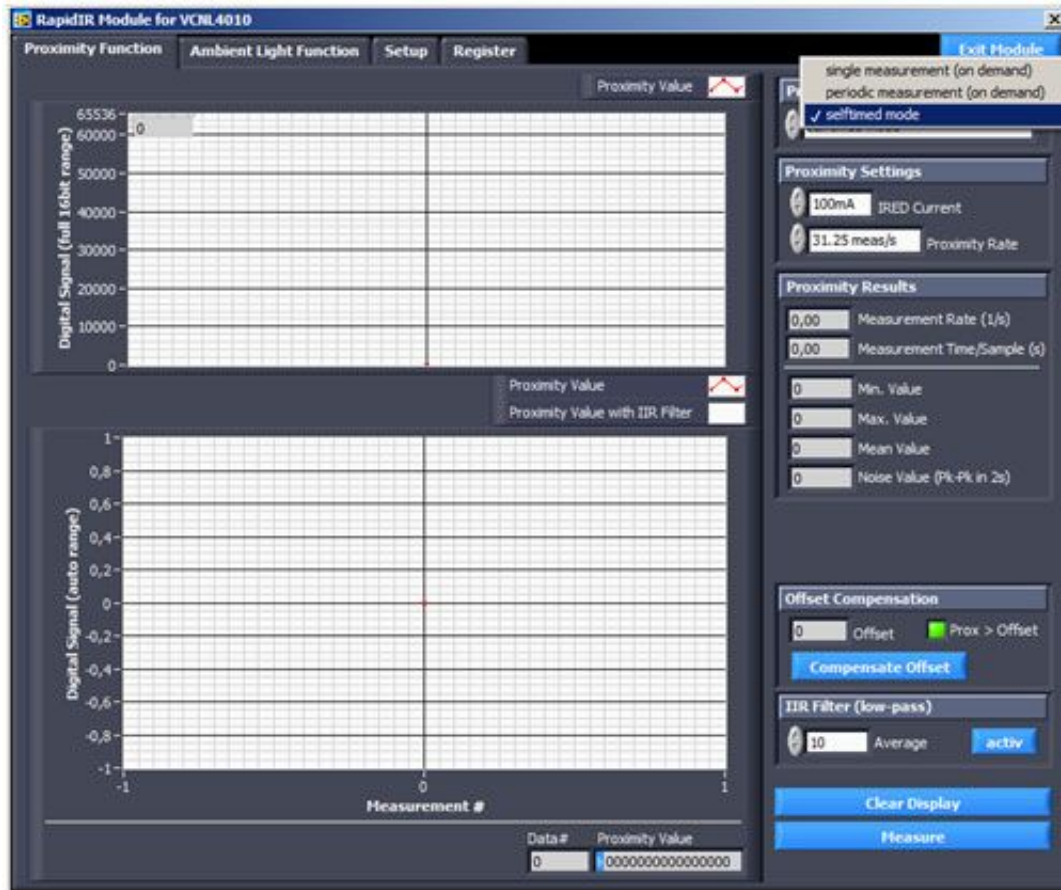

Fig. 1 - Ambient Light Values vs. Illuminance

VCNL4000, VCNL4010, and VCNL4020 Demo Kit



Screen Shot 4

Interrupt

In order to set interrupt thresholds, it is necessary to determine the offset counts for the sensor. The offset count is application specific so it can only be determined by assembling the sensor with surrounding components with the cover or window above it. Offset counts are initially determined during development and may again be measured during assembly or final test of the end product. To determine the offset counts, the sensor's proximity

performance must be determined using the worst reflective object required to be detected at the desired distance it is to be detected. By adjusting the current of the infrared emitter, the range can be established. By adjusting the measurement speed, the response rate desired can be established. All these parameters together yield the total offset counts of the sensor without an object in range.

VCNL4000, VCNL4010, and VCNL4020 Demo Kit

Example:

The sensor without any cover and close surrounding of other objects/components delivers about 2300 counts with an infrared emitter current of 100 mA. With some higher components close by and with a less transmissive cover this easily could rise up to 5000 or even 20 000 counts, depending on the distance and reflectivity of the cover used. As shown in screen shot 5, the offset counts are 5400. As an example, the application needs to detect an object at a

distance of 5 cm. After some development trials, the sensor measures 5500 counts when the object is 5 cm distance and the forward current is 100 mA. For the application, the upper threshold will be set to 5500 counts, the green line in screen shot 5. When the counts exceed this threshold, in other words when an object is at 5 cm distance or less, an interrupt will be generated.

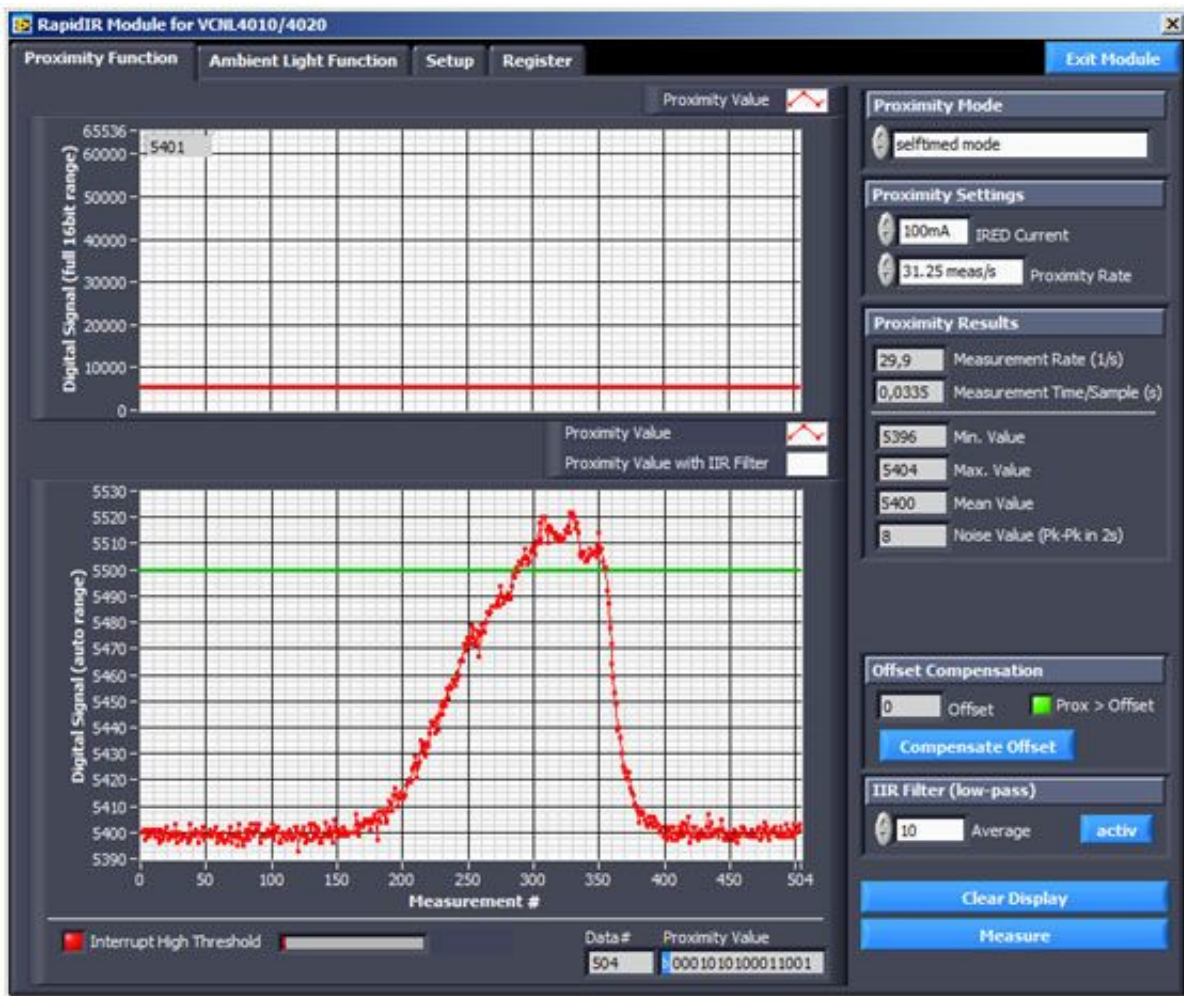

Screen Shot 5

VCNL4000, VCNL4010, and VCNL4020 Demo Kit

Screen shot 6 shows the Setup page where the Interrupt Control variables are set or defined:

- Upper threshold value
- Lower threshold value
- Number of measurements above or below a threshold needed to generate an interrupt
- Enable interrupt threshold function
- Threshold applies to proximity or ambient light.

To avoid reacting to momentary object proximity, some applications will want to wait until several measurements are taken indicating an object is present or has been removed before generating an interrupt. The “Threshold hits needed” value is set to 4 in screen shot 6. The upper threshold is set to 5500 counts as discussed above. There is no lower threshold. The interrupt is enabled as indicated by the green arrow on the toggle button. Finally, the interrupt is for proximity because the green arrow is not illuminated. If it were for ambient light, the green arrow would be illuminated. Note that by clicking on the “show in graph” button under each threshold value, the user will graphically be shown the threshold value in relation to the offset and current readings.

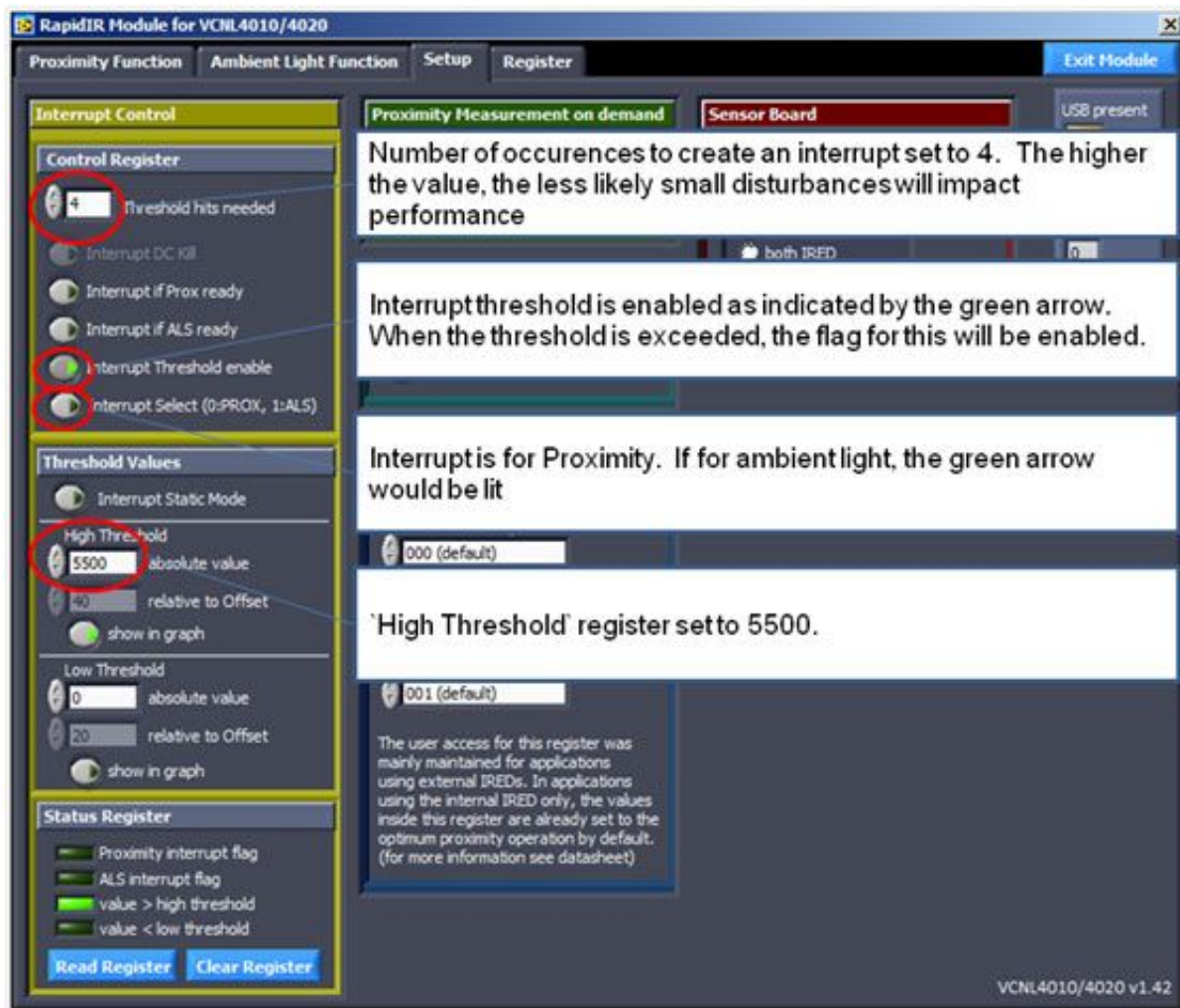

Screen Shot 6

VCNL4000, VCNL4010, and VCNL4020 Demo Kit

Screen shot 7 demonstrates how a brief event, for example a quick swipe of a hand, exceeded the threshold but the number of consecutive measurements was less than 4 so an interrupt was not generated. Following this event, an object is within 5 cm for long enough for an interrupt to be generated. The “Interrupt High Threshold” indicator in the lower left corner is illuminated (red). Once an object is

detected, there are a number of possible actions an application can take. Continuous polling can be initiated to monitor the object's proximity. Or, the current interrupt could be cleared, threshold values reprogrammed and the microcontroller freed to perform other activities or to sleep until an event occurs that generates a new interrupt.

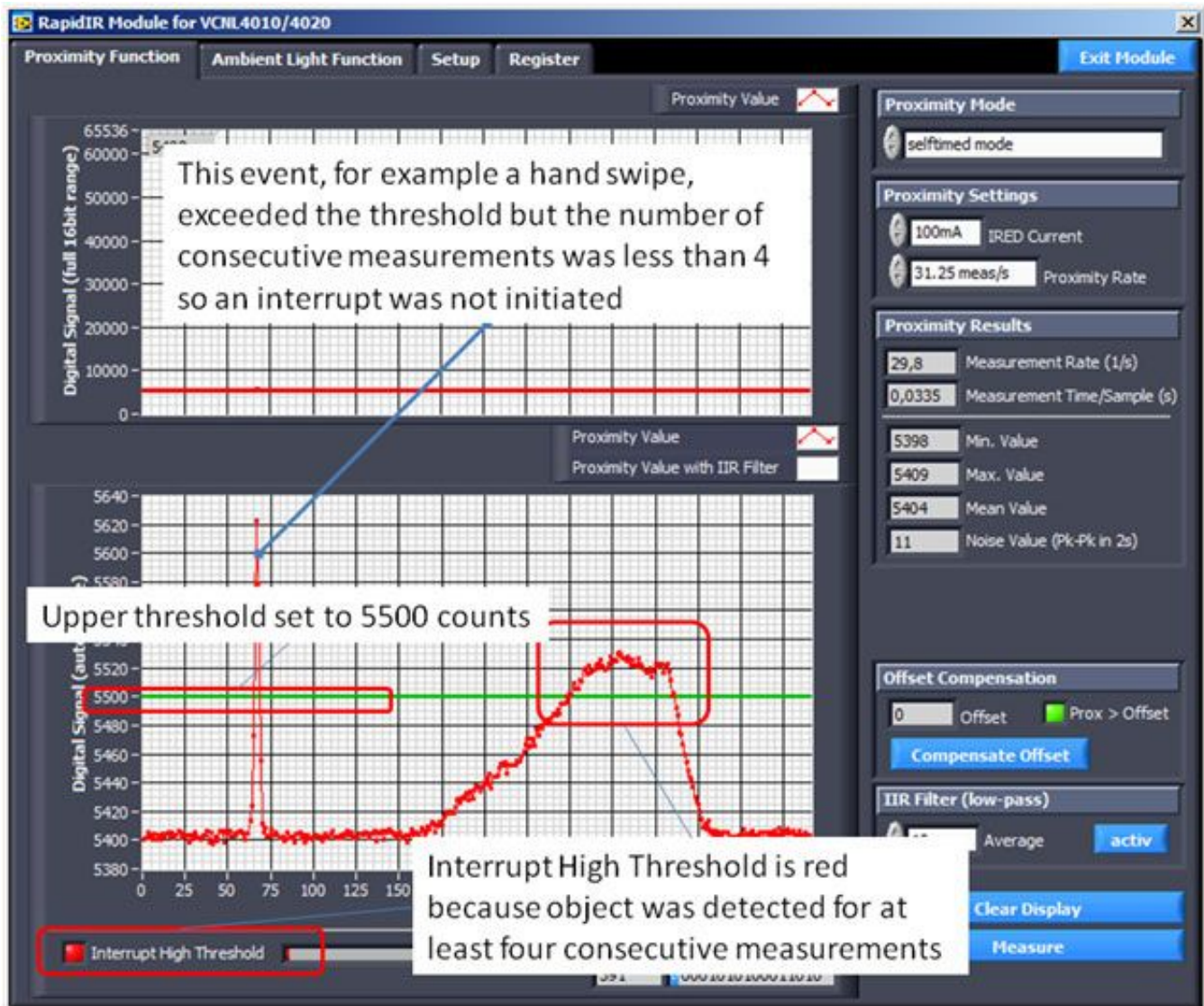

Screen Shot 7

VCNL4000, VCNL4010, and VCNL4020 Demo Kit

Screen shot 8 shows how the upper threshold is reprogrammed to be high enough so that it will not 'be in play' anymore, for example 65 535 counts. To be able to show it in the lower window, the value has been set to 5600 for this example. The application needs to now initiate an action when the object is no longer present. In a smart phone application for example, the screen backlight and touch function is turned off when the phone is brought to the users ear (upper threshold) and should turn back on when

the phone is removed from being near the user's ear (lower threshold). The lower threshold should be above the offset counts but below the present proximity counts. In this example, the lower threshold is set to 5450 counts. Screen shot 8 also shows that the object is removed and the signal goes below the lower threshold. The "Interrupt Low Threshold" indicator in the lower left corner is illuminated (red).

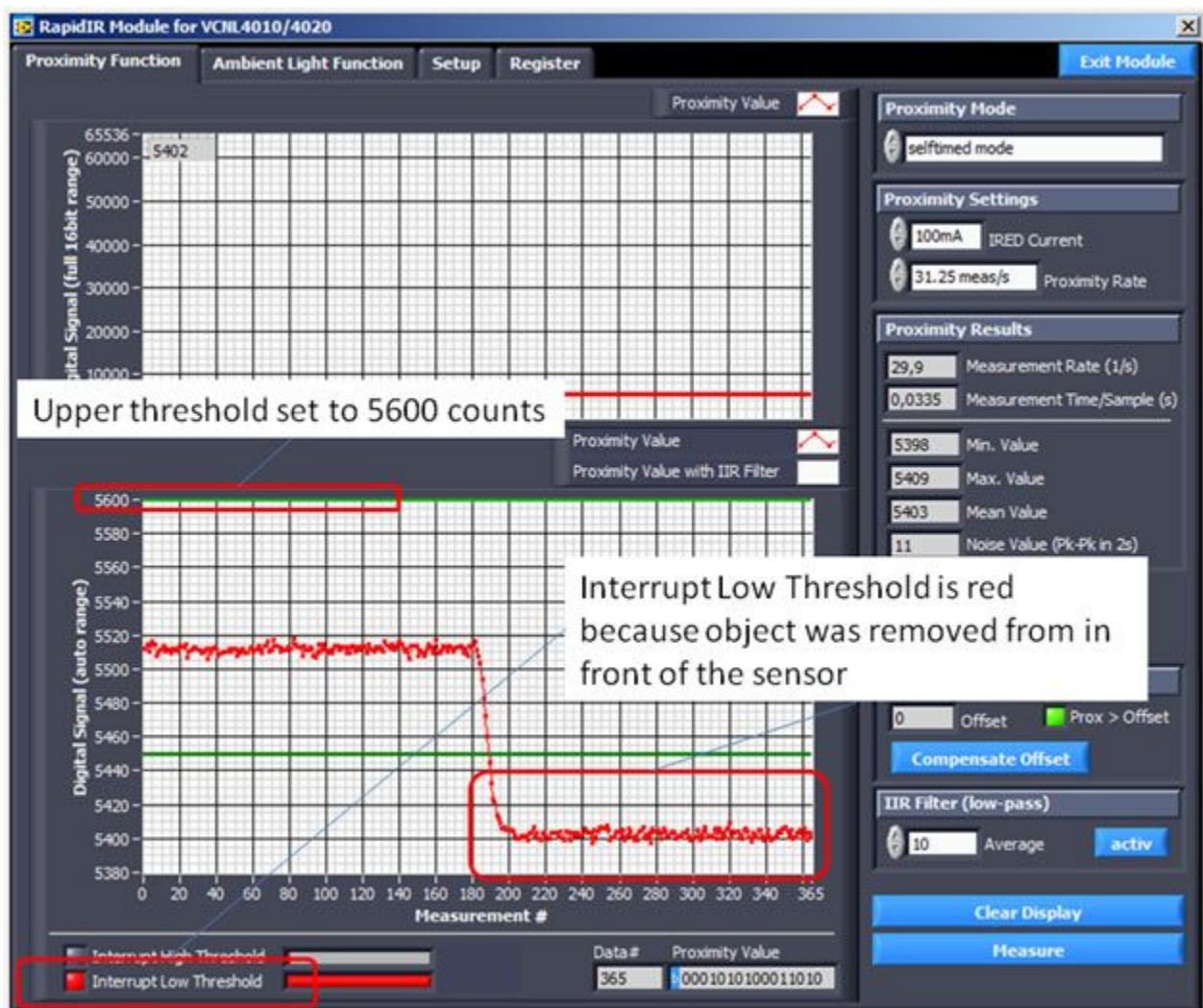

Screen Shot 8

VCNL4000, VCNL4010, and VCNL4020 Demo Kit

Screen shot 9 shows that the status bit indicator for low threshold, “value < low threshold”, has been illuminated (**int_th_lo = 1**).

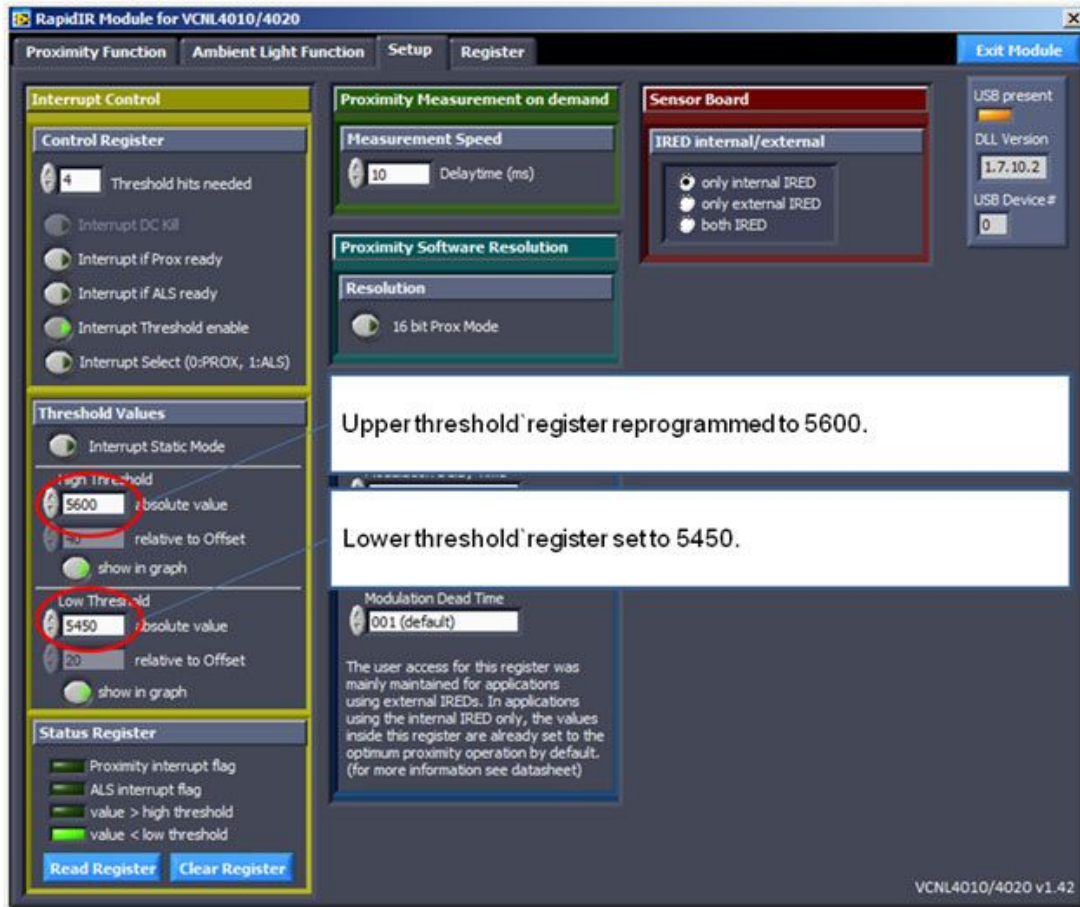

Screen Shot 9

External Emitter Settings

In screen shot 10 the setup screen for the VCNL4010 and VCNL4020 is shown. Under the red sensor board section, the default “internal emitter” indicator is illuminated. Users have the option of selecting the use of an external emitter or using both internal and external emitter. The supply voltage for the external emitter is called VIR and connected via the USB controller board to a 3.3 V power supply, see Figure 6, 7, and 8. It can be connected to a separate power supply. If internal and external infrared emitters will be driven in series, they need to be connected to a higher voltage.

The blue proximity modulator adjustment section of the setup screen shows default values for the use of the integrated infrared emitter. When using external emitters or a combination of an internal and external emitter, the modulation delay time, modulation dead time, and proximity

frequency may need to be adjusted. Please refer to the VCNL4010 and VCNL4020 Application Notes for further details.

The green proximity measurement on demand section of the Setup screen allows users to adjust the delay between two consecutive measurements. Any value between 1 and 10 000 can be entered in the field. A value of 1 results in 1 ms between measurements (200 measurement/s) while a value of 10 000 results in about 10 s between measurements.

APPLICATION NOTE



VCNL4000, VCNL4010, and VCNL4020 Demo Kit

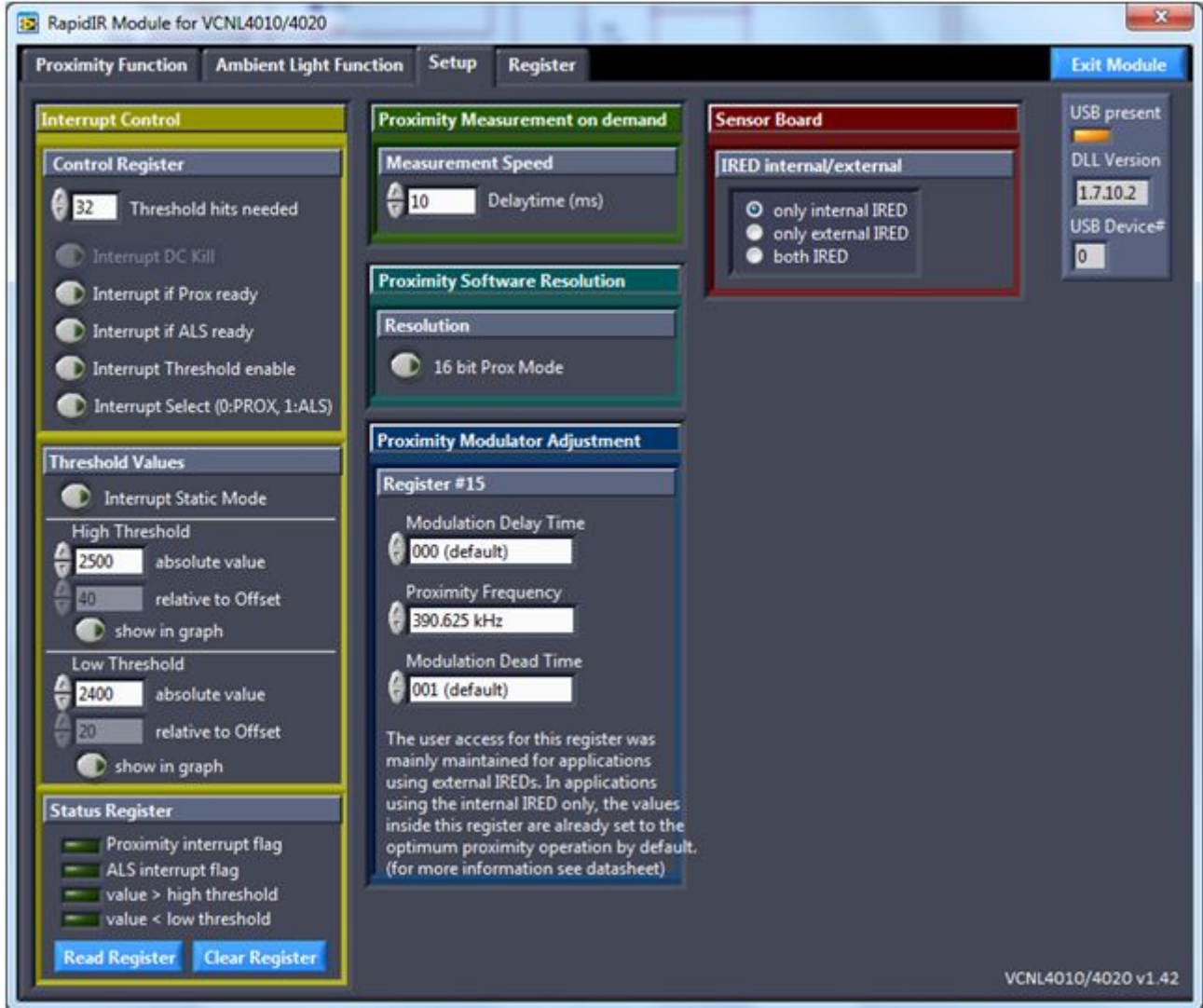

Screen Shot 10

VCNL4000, VCNL4010, and VCNL4020 Demo Kit

SCHEMATIC

VCNL4000 Board Layout

The sensor board includes the VCNL4000 sensor and a 470nF capacitor. It is connected to the common 3.3 V power supply used for the infrared emitter on Pin1 and the ASIC_V_{DD} on Pin7. As is shown in Figure 3, large areas of the top side are ground plane to avoid ESD problems when handling the board. The odd-numbered pins are on top side and the even-numbered on the bottom side



Fig. 3 - VCNL4000 Sensor Board



Fig. 4 - VCNL4010 Sensor Board

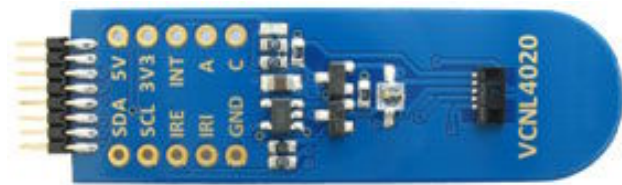

Fig. 5 - VCNL4020 Sensor Board

VCNL4010 and VCNL4020 Board Layout

The VCNL4010 and VCNL4020 sensor boards, Figure 4 and 5, have test points to allow simple evaluation and/or connection to the customer's application board. The boards also include an external emitter (VSMF2890GX01) to increase the measurement range to 500 mm and supporting FET's to use the integrated emitter, the external emitter or both in series.

Schematic

Only 4 wires are needed to connect to VCNL40x0:

- SDA (J1) and SCL (J3) need to be connected to the microcontroller
- V_{DD} (J11) needs to be connected to the power supply
- Ground pin (J2/J15) needs to be connected to the application ground plane.

See Figure 6, 7, and 8.

Useful Links

I²C specification Version 2.1:
www.nxp.com/acrobat_download2/literature/9398/39340011.pdf

I²C specification Version 3.0:
www.nxp.com/documents/user_manual/UM10204.pdf

Male pin connector 2199SB-XXG-301523

www.almita.com.tw/pro25.htm

Female pin connector 2200SG-XG-A1 ???

VCNL4000, VCNL4010, and VCNL4020 Demo Kit

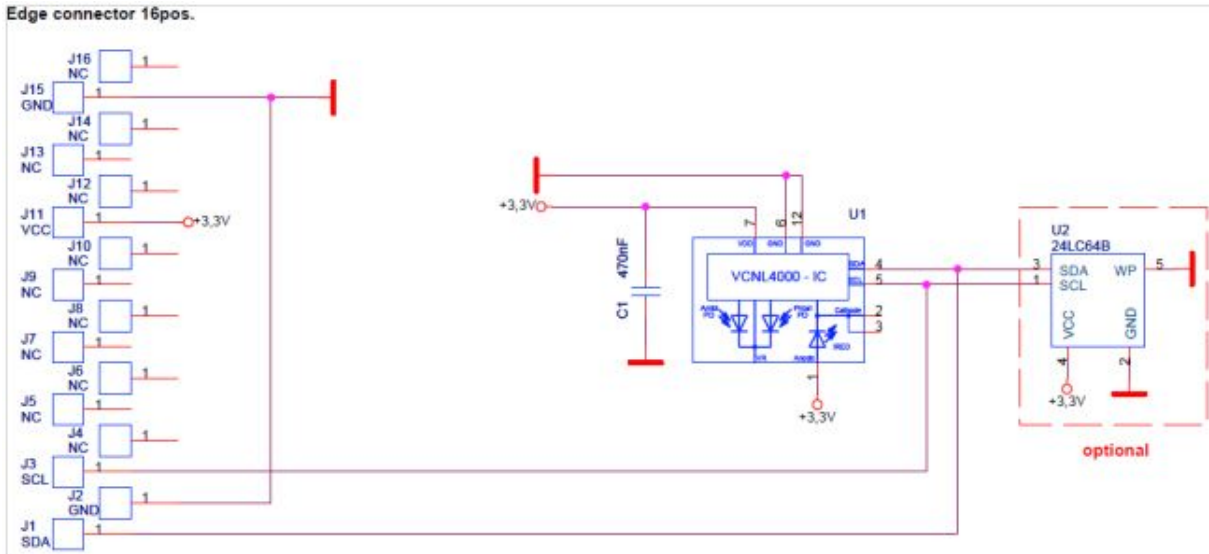

Fig. 6 - Circuit diagram of VCNL4000 Sensor Board

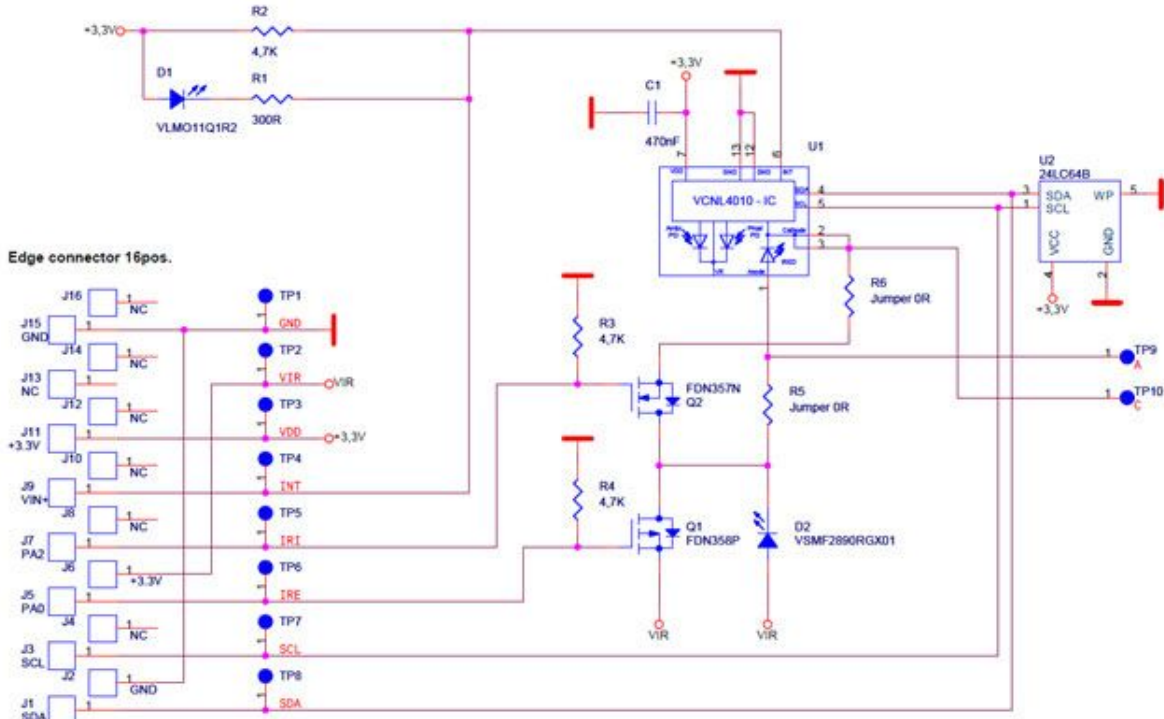

Fig. 7 - Circuit diagram of VCNL4010 Sensor Board

VCNL4000, VCNL4010, and VCNL4020 Demo Kit

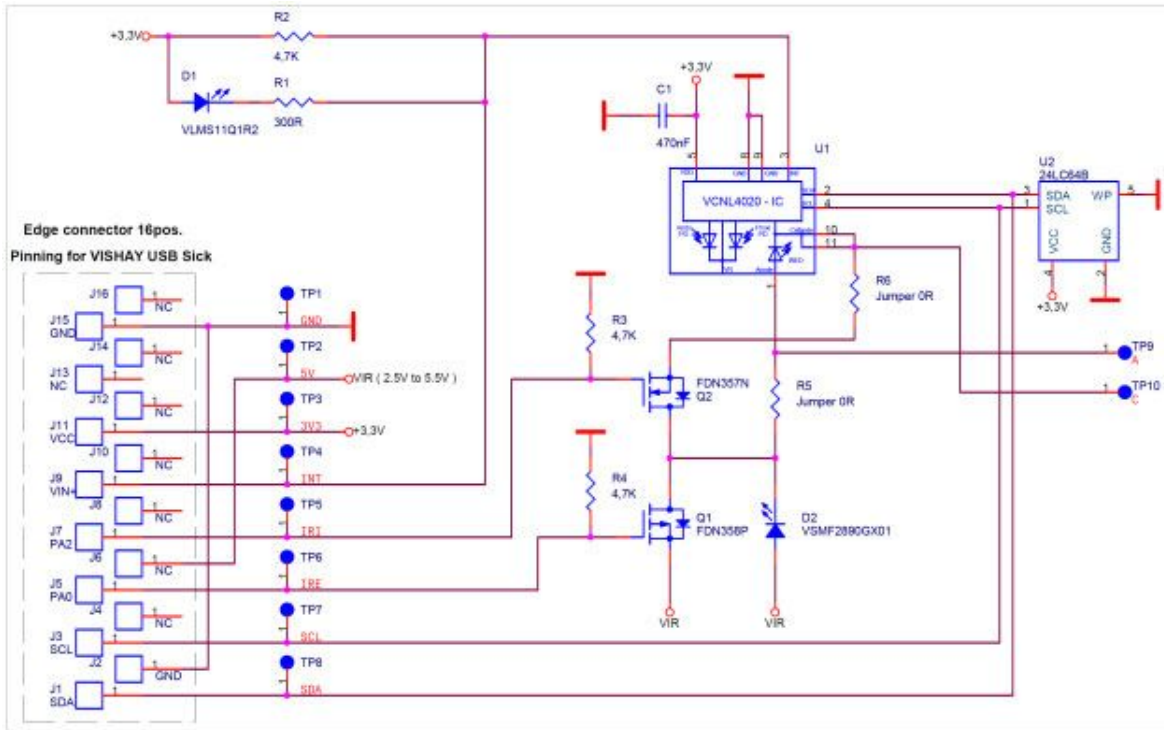

Fig. 8 - Circuit diagram of VCNL4020 Sensor Board

The two switching information (IRI and IRE) are delivered from the USB controller and follow below given specification:

IRI	IRE	IRED operating
L	L	only internal IRED
L	H	both IREDs
H	L	forbidden
H	H	only external IRED

Fig. 9 - GPIO signals for VCNL4010 Sensor Board

Mouser Electronics

Authorized Distributor

Click to View Pricing, Inventory, Delivery & Lifecycle Information:

Vishay:

[VCNL4000DEMOKIT](#)