

#### FEATURES

- Demonstrates a complete 2 channel digitally-controlled microphone preamplifier system based on THAT5263 IC
- Controls gain of two microphone preamplifiers
- Balanced main audio input/output on XLR connectors
- Balanced TRS line input with -20dB pad
- Switchable phantom power (with external +48V)
- Supports pro audio signal levels: +26 dBu (input and output,  $\pm 15V$  supplies)
- Gain adjustable in 3 dB steps from 0 dB to 51 dB
- Easy to use PC Graphical User Interface software
- Generous prototyping area

#### DESCRIPTION

The THAT 5263-DEMO Digitally-Controlled Mic Preamp Demo Board allows developers to evaluate the THAT5263 digital gain controller IC with THAT differential output microphone preamplifiers. A fully-featured microphone preamplifier is demonstrated

with phantom power switching and fault protection, mic/line inputs, RFI filtering, and output conditioning. The board is controlled by a user-friendly PC graphical user interface over USB.

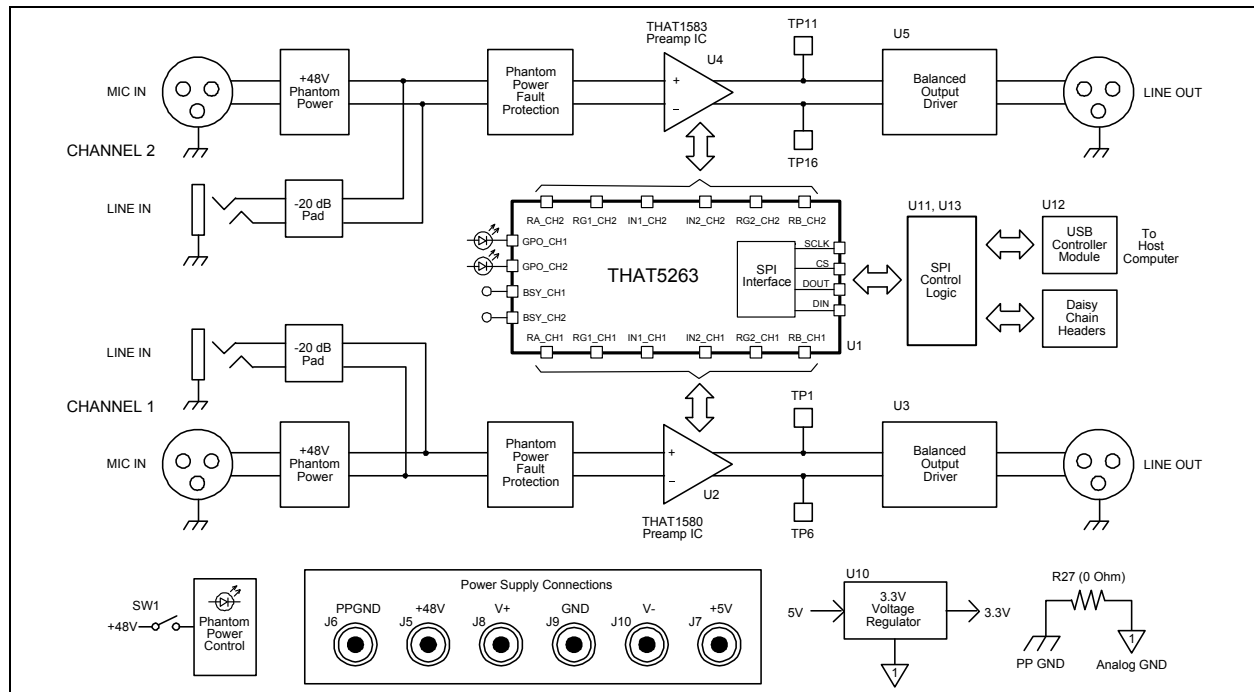

Figure 1. THAT5263 Simplified Application Circuit

## **Overview**

The THAT5263 is a digital gain controller for low-noise, analog, differential, current-feedback audio preamplifiers. When used in conjunction with an appropriate analog gain block (e.g. THAT 1580 or 1583), the 5263 can digitally control gain from 0dB to 51dB in 3dB steps, while preserving low noise and distortion. It operates from  $\pm 5V$  to  $\pm 17V$  supplies, supporting input signal levels as high as +27 dBu (at 0dB gain,  $\pm 17 V$ ) without an input pad.

The THAT5263-DEMO Board demonstrates the 5263 mated with the 1580 and 1583 mic preamplifier ICs in a typical circuit. An easy to use USB Graphical User Interface provides total control over all 5263 features. Developers can take advantage of the generous prototyping area to customize the circuit for their own application.

## **Connections**

### **Power**

The USB interface runs on USB bus power, but the rest of the demo board requires an external power supply. +/-15 V (maximum +/-17V) supplies the analog circuitry. +48V phantom power is input (not generated on the board) and switched on and off via the on-board Phantom Power switch. Note that the ground return for +48V phantom power is via the PPGND and connects to the Analog ground via a zero ohm resistor. connector. The +5V input is regulated on board to 3.3V and supplies the digital logic.

### **Audio Input**

The Neutrik combo connector accepts an XLR or 1/4" TRS cable. The 1/4" TRS signal path includes a 20dB pad in order to support line levels.

### **Audio Output**

The Output XLR connector provides access to the balance audio output signal. Please note that the differential attenuator/ output buffers (U3/U5) add a small amount of noise and distortion to the signal and it is therefore recommended that test points TP10 - TP11 be used to measure performance of the mic preamp circuit in isolation.

### **USB**

A PC must be plugged into the demo board via USB in order to control parameters in the 5263. Take care not to hot plug the demo board while the GUI software is running as this will sometimes crash the Windows drivers.

### **General Purpose Outputs (GPOA, GPOB) and Busy Signal Outputs (BSYA, BSYB)**

Each channel of the 5263 provides a GPO in addition to a digital busy signal (BSY). These pins are connected to header P12 via small series resistors. The GPOs are also connected to LEDs D10 and D11. The LEDs can be enabled/disabled by the on-board DIP switches SW2-1 and SW2-2. When enabled, these LEDs can be controlled with the GPO check box on the GUI.

### **Connecting Multiple Demo Boards in Daisy Chain Mode**

Headers P9 and P10 provide easy access to the SPI signals for linking multiple pairs of 5263 channels. Please refer to the 5263 Data Sheet for complete details. Note that the on-board DIP switches SW2-3 and SW2-4 control the Daisy Chain function. These switches must be set to the OFF position (toward the left side of the board) in order to insure proper operation in the normal two channel mode.

## Software Set-up and Operation

Download the latest 5362 Demo Board GUI software from the THAT Corporation web site

In the .zip file you will find the GUI executable along with other associated demo board documentation. Simply un-zip the file and place the MicPre\_v1\_3.exe in some convenient location on your PC.

Once the hardware has been set up as described above, double click the MicPre.exe icon and the GUI should appear:

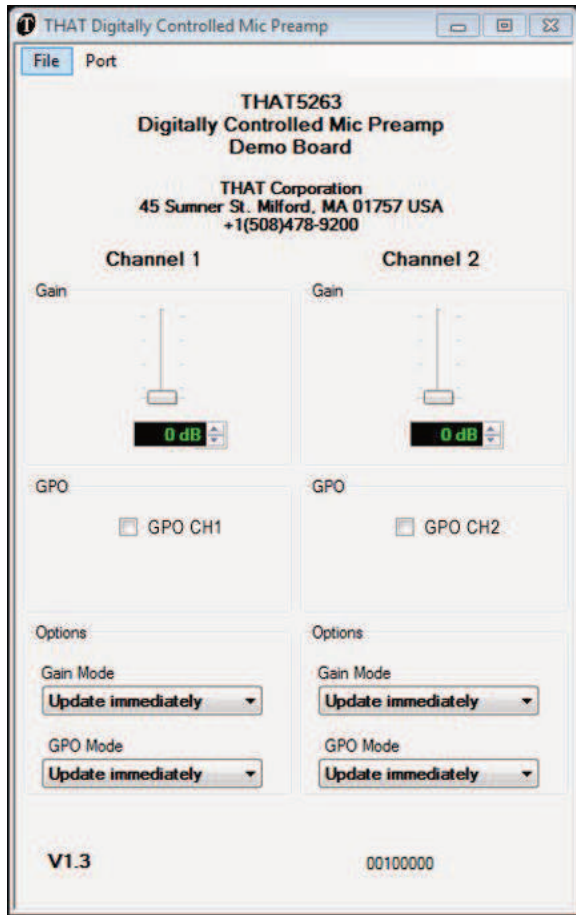

Figure 2. 5263-DEMO GUI

Next connect the GUI to the demo board by clicking on the Port pull down menu at the top and selecting Reconnect.

The small green LED on the USB module should blink, indicating that communications have been established. Try the GPO check boxes on the GUI and the red LEDs on the demo board should light up,

indicating that the GUI is successfully talking to the 5263.

If the GUI fails to recognize the demo board (most likely caused by a missing USB connection) you will see the following error message:

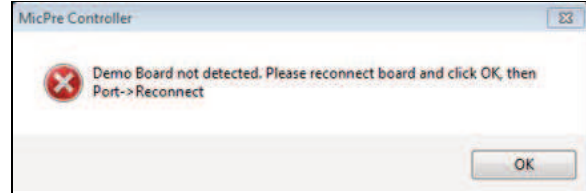

Figure 3. 5263-DEMO software error message.

If this message appears, you can click OK and the GUI will open, but there will be no connection to the demo board. Once the source of the problem has been resolved (i.e. Turn on the power or connect the missing USB cable), use the Port=>Reconnect pull down to establish communications.

The Port=>Reconnect pull down can be used any-time to reestablish the USB link between the GUI and demo board.

Select "Update immediately" or "Update on zero crossings" from the Gain Mode and GPO Mode drop down menus.

Move the gain slider to adjust gain of the 5263. Gains are continuously adjusted as you move the slider. You may also adjust the gain slider by first giving it scope (clicking it with the mouse) and then pressing the UP and DOWN arrow keys on your computer keyboard, or by clicking the up or down arrow buttons next to the numeric gain text box below the gain slider.

### Jumper Options

T-Bias Jumpers, P4, P8

The input circuit provides jumpers (P4, P8) which enable/disable the "T-Bias" function. With the shunts installed, T-Bias is disabled and the circuit provides a 2kΩ differential input impedance to the XLR input. With the shunts removed, T-Bias is enabled and provides a high common mode impedance (ideal for both mic and line inputs) but maintains a modest differential impedance.

**Appendix A. Schematic (1 of 3)**

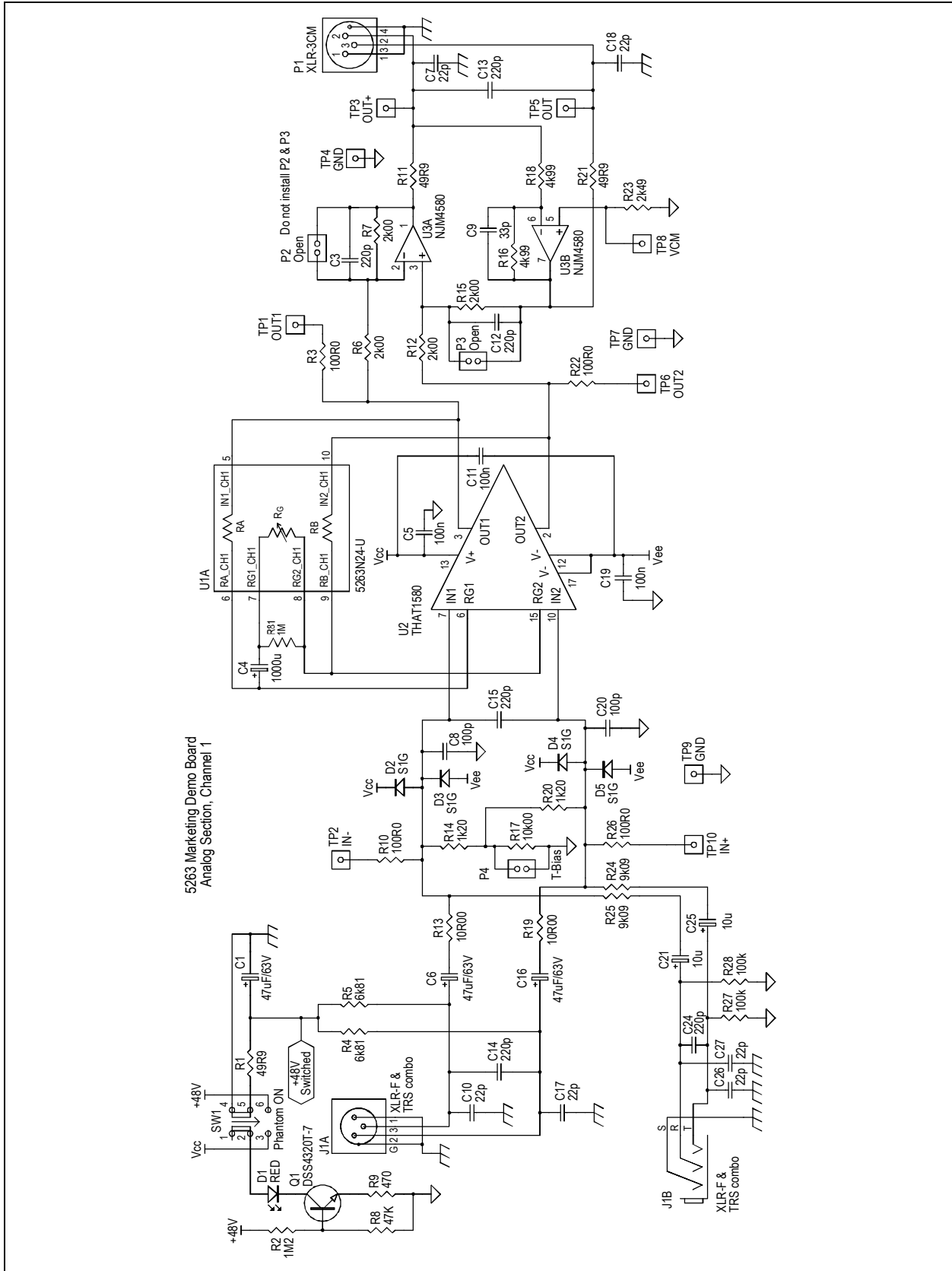

### Appendix A. Schematic (2 of 3)

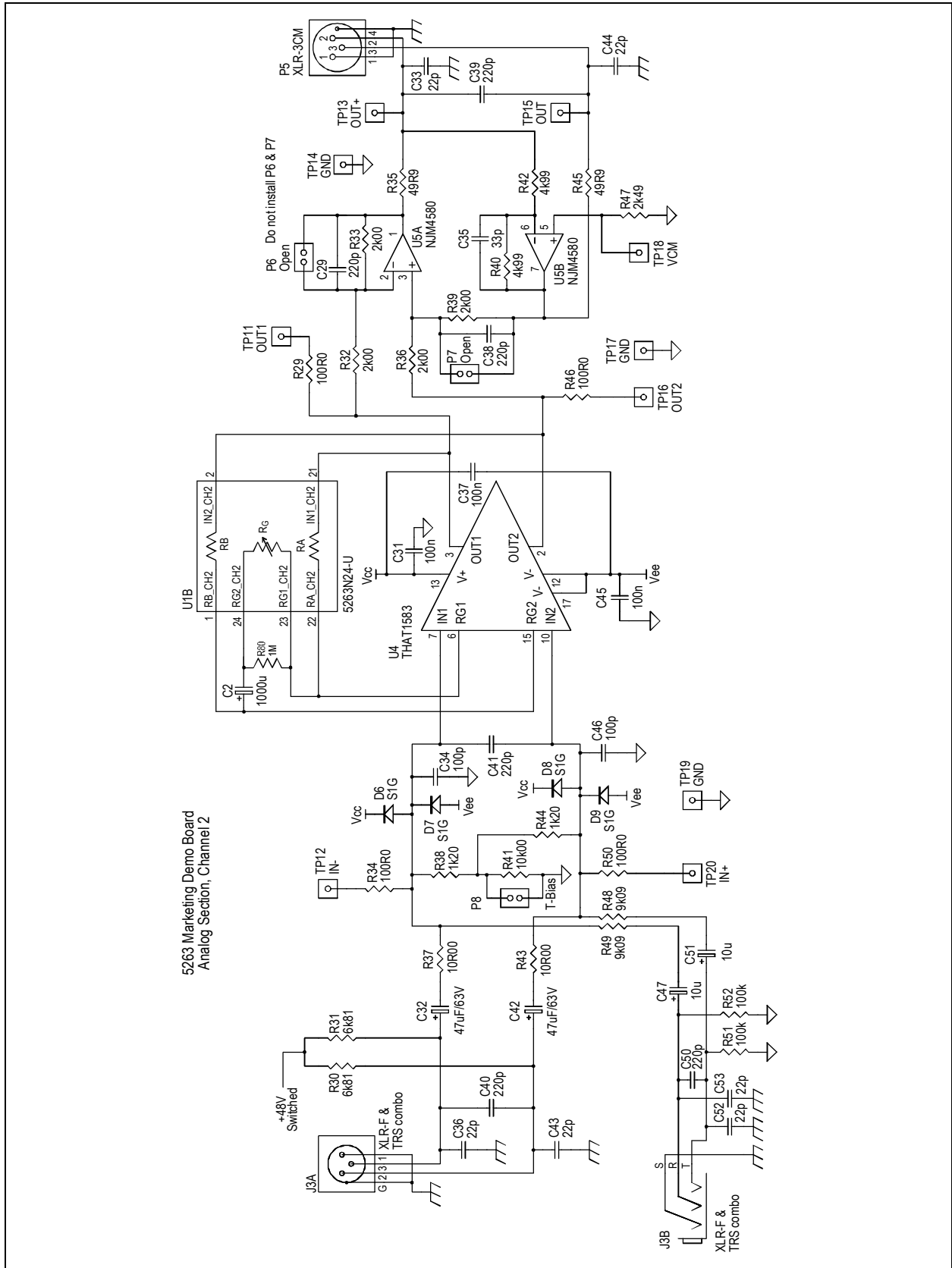

### Appendix A. Schematic (3 of 3)

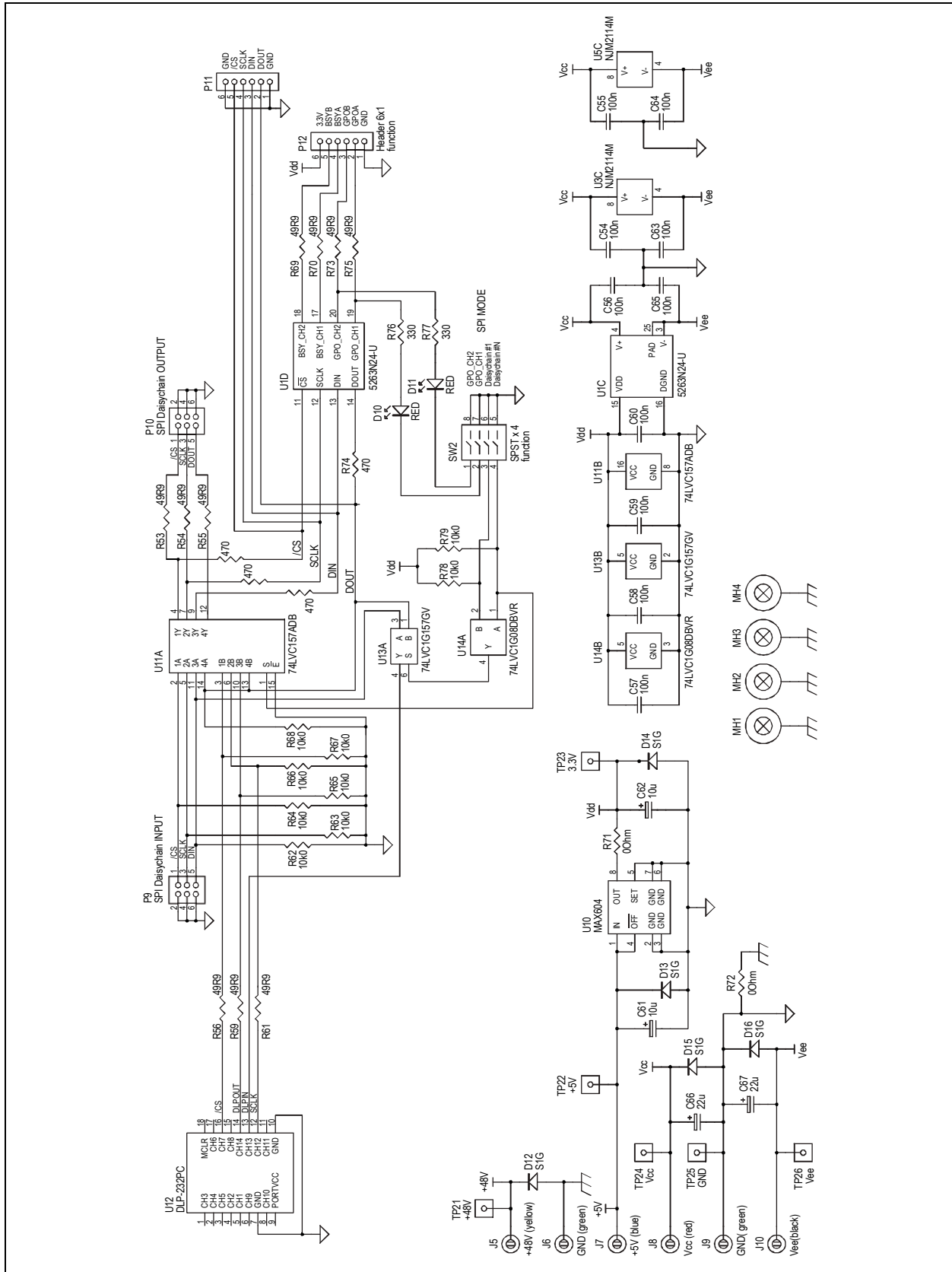

**Appendix B. Bill of Materials**

Item	Qty	P/N	Title	Detail	Reference(m)	Mfr	Mfr P/N
1	2	030000	RESISTOR	0R 100MW 5% THICK FILM 200 PPM 0603	R71, R72	Panasonic	ERJ-3GEY0R00V
2	9	031002	RESISTOR	10K0 100MW 1% THICK FILM 100 PPM 0603	R62, R63, R64, R65, R66, R67, R68, R78, R79	Vishay Dale	CRCW06031002FRT1
3	14	034999	RESISTOR	49R9 100MW 1% THICK FILM 100 PPM 0603	R53, R54, R55, R56, R57, R58, R59, R60, R61, R69, R70, R73, R74, R75	Xicon	302-49.9-RC
4	4	070551	RESISTOR	10R00 1/4W 0%1 MF 50 PPM AXIAL	R13, R19, R37, R43	VPR	A010.00M3EB
5	4	070567	RESISTOR	6K81 1/4W 0%1 MF 25 PPM AXIAL	R4, R5, R30, R31	IRC	RC55LF-D-6K81-B-B
6	1	070568	RESISTOR	49R90 1/4W 0%1 MF 25 PPM1206	R1	Vishay Dale	TNPW120649R9BEEN
7	4	070570	RESISTOR	49R90 1/10W 0%1 THIN FILM 25 PPM 0805	R11, R21, R35, R45	Stackpole Electronics	RNCS0805BKE49R9
8	4	080003	RESISTOR	100K 63MW 1% THIN FILM 100 PPM 0603	R27, R28, R51, R52	Venkel, Ltd.	TFCR0603-16W-C- 1003FT
9	8	084001	RESISTOR	100R0 100MW 1% THIN FILM 25 PPM 0805	R3, R10, R22, R26, R29, R34, R46, R50	VPR	A100.00E3EF
10	2	084003	RESISTOR	10K00 100MW 0%5 THIN FILM 25 PPM 0805	R17, R41	Susumu Co	RR1220P-103-D
11	1	084007	RESISTOR	1M2 0.125W 1% TF 100 PPM 0805	R2	Vishay Dale	CRCW08051M21FKEA
12	8	084008	RESISTOR	2K00 100MW 0%1 THIN FILM 25 PPM 0805	R6, R7, R12, R15, R32, R33, R36, R39	Susumu	RR1220P-202-B-T5
13	4	084009	RESISTOR	9K09 125MW 0%1 THIN FILM 25 PPM 0805	R24, R25, R48, R49	Susumu Co	RG2012P-9091-B-T5
14	4	084011	RESISTOR	4K99 100MW 0%5 THIN FILM 25 PPM 0805	R16, R18, R40, R42	Susumu	RR1220P-4991-D-M
15	1	084012	RESISTOR	47K0 125MW 1% THIN FILM 100 PPM 0805	R8	Yageo	RC0805FR-0747KL
16	1	084013	RESISTOR	470R 125MW 1% TF 100 PPM 0805	R9	Yageo	RC0805FR-07470RL
17	2	084014	RESISTOR	2K49 125MW 1% THIN FILM 100 PPM 0805	R23, R47	Stackpole Electronics	RNCP0805FTD2K49
18	2	084015	RESISTOR	330R 125MW 1% TF 100 PPM 0805	R76, R77	Yageo	RC0805FR-07330RL
19	4	084061	RESISTOR	1K20 0.25W 0%1 THIN FILM 25 PPM 1206	R14, R20, R38, R44	Vishay Dale	TNPW12061K20BEEN
20	10	131054	CAPACITOR	100N 10% 50V X7R CM 0603	C54, C55, C56, C57, C58, C59, C60, C63, C64, C65	Murata Electronics	GRM188R71H104K
21	6	131062	CAPACITOR	100N 10% 50V X7R CM 0805	C5, C11, C19, C31, C37, C45	Murata Electronics	GRM21BR71H104KA0 1L
22	4	131063	CAPACITOR	100P 10% 50V X7R CM 0805	C8, C20, C34, C46	Murata Electronics	GRM2165C1H101JA01 D
23	12	131065	CAPACITOR	220P 5% 50V NP0 CM LOW ESR 0805	C3, C12, C13, C14, C15, C24, C29, C38, C39, C40, C41, C50	AVX	08055A221JAT2A
24	12	131066	CAPACITOR	22P 10% 50V NP0 CM LOW ESR 0805	C7, C10, C17, C18, C26, C27, C33, C36, C43, C44, C52, C53	Panasonic	ECJ-2VC1H220J
25	2	131067	CAPACITOR	33P 5% 50V NP0 CM LOW ECR 0805	C9, C35	Panasonic	ECJ-2VC1H330J
26	4	137010	CAPACITOR	10U 20% 50V ALUMINUM SMT	C21, C25, C47, C51	Nichicon	UWX1H100MCL1GB
27	2	137011	CAPACITOR	10U 20% 25V ALUMINUM SMT	C61, C62	United Chemi-Con, Inc.	EMVA250ADA100MD5 5G
28	2	137012	CAPACITOR	22U 20% 25V ALUMINUM LOW IMP SMT	C66, C67	Panasonic	EEV-FC1E220P
29	5	137013	CAPACITOR	47U 20% 63V AL LOW ESR SMT	C1, C6, C16, C32, C42	Panasonic	EEE-TG1J470P
30	2	137025	CAPACITOR	1000U20% 6.3V ALUMINUM SMT	C2, C4	Nichicon	UWT0J102MNL1GS



Item	Qty	P/N	Title	Detail	Reference(m)	Mfr	Mfr P/N
31	13	140017	DIODE	RECTIFIER 1A 400V DO-214AC S1G	D2, D3, D4, D5, D6, D7, D8, D9, D12, D13, D14, D15, D16	Diodes, Inc.	S1G-13-F
32	1	140035	TRANSISTOR	BIPOLAR NPN 20V 2A SOT-23DSS4320T-7	Q1	Diodes, Inc.	DSS4320T-7
33	3	140146	LED	RED HIGH BRIGHTNESS	D1, D10, D11	Rohm	SLA-560LT3F
34	1	146292	IC	REGULATOR VOLTAGE LOW DROP 3.3V SO-8 MAX604CSA	U10	Maxim / Dallas	MAX604CSA
35	2	146380	IC	OP AMP DUAL LOW NOISE DMP-8 NJM2114M	U3, U5	NJR Corporation	NJM2114M
36	1	146381	IC	MULTIPLEXER QUAD 2 INPUT 74LVC157ADB,112	U11	NXP	74LVC157ADB,112
37	1	146462	IC	MULTIPLEXER SINGLE 2 INPUT 74LVC1G157GV,125	U13	NXP Semiconductors	74LVC1G157GV,125
38	1	146692	IC	AND GATE SINGLE SMT SN74LVC1G08DBVR	U14	Texas Instruments	SN74LVC1G08DBVR
39	1	1580N16-U	IC	IC DIFFERENTIAL AUDIO PREAMPLIFIER LOW NOISE	U2	THAT Corporation	1580N16-U
39A	1	1583N16-U	IC	IC DIFFERENTIAL AUDIO PREAMPLIFIER LOW NOISE	U4	THAT Corporation	1583N16-U
40	1	250169	SWITCH	DIP SPST 4P DIP8	SW2	CTS Corporation	206-4
41	1	250177	SWITCH	PUSHBUTTON DPDT	SW1	E-Switch	PBH2UEENAGX
42	1	270914	PCB	5263 Marketing Demo Board			
43	1	280020	CONN	1P BINDING POST CHASSIS MNT BLUE	J7	Pomona Electronics	3760-6
44	1	280100	CONN	1P BINDING POST CHASSIS MNT YELLOW	J5	Pomona Electronics	3760-4
45	2	280440	CONN	60P 3 X 2 MALE GOLD	P9, P10	3M	2306-6121TG
46	6	280461	CONN	2P MALE STR GOLD 0.1" 2 X 1	P2, P3, P4, P6, P7, P8	Samtec USA	TSW-102-07-G-S
47	2	280499	CONN	6P MALE GOLD 0.1" 6 X 1	P11, P12	Molex	22-28-4063
48	1	280586	CONN	1P BINDING POST CHASSIS MNT RED	J8	Pomona Electronics	3760-2
49	2	280587	CONN	1P BINDING POST CHASSIS MNT GREEN	J6, J9	Pomona Electronics	3760-5
50	1	280588	CONN	1P BINDING POST CHASSIS MNT BLACK	J10	Pomona Electronics	3760-0
51	26	280638	CONN	1P 1 X 1 TEST POINT SMT 0.015 THICK	TP1, TP2, TP3, TP4, TP5, TP6, TP7, TP8, TP9, TP10, TP11, TP12, TP13, TP14, TP15, TP16, TP17, TP18, TP19, TP20, TP21, TP22, TP23, TP24, TP25, TP26	Keystone Electronics Corporation	5016
52	2	280651	CONN	3P XLR-3C MALE RT ANGLE	P1, P5	Neutrik USA Inc.	NC3MAH
53	2	280652	CONN	3P XLR - COMBO STEREO RT ANGLE	J1, J3	Neutrik USA Inc.	NCJ6FI-H
54	4	311036	HARDWARE	STANDOFF 4-40 X 1/4" X 1" HEX SWAGE BRASS	MH1, MH2, MH3, MH4	RAF	3559-B-440-B-0
55	1	470644-00	PCBA	MODULE USB MICRO-CONTROLLER DLP-232PC		DLP Design, Inc	DLP-232PC

**Appendix C. PCB Layout (1 of 3)**

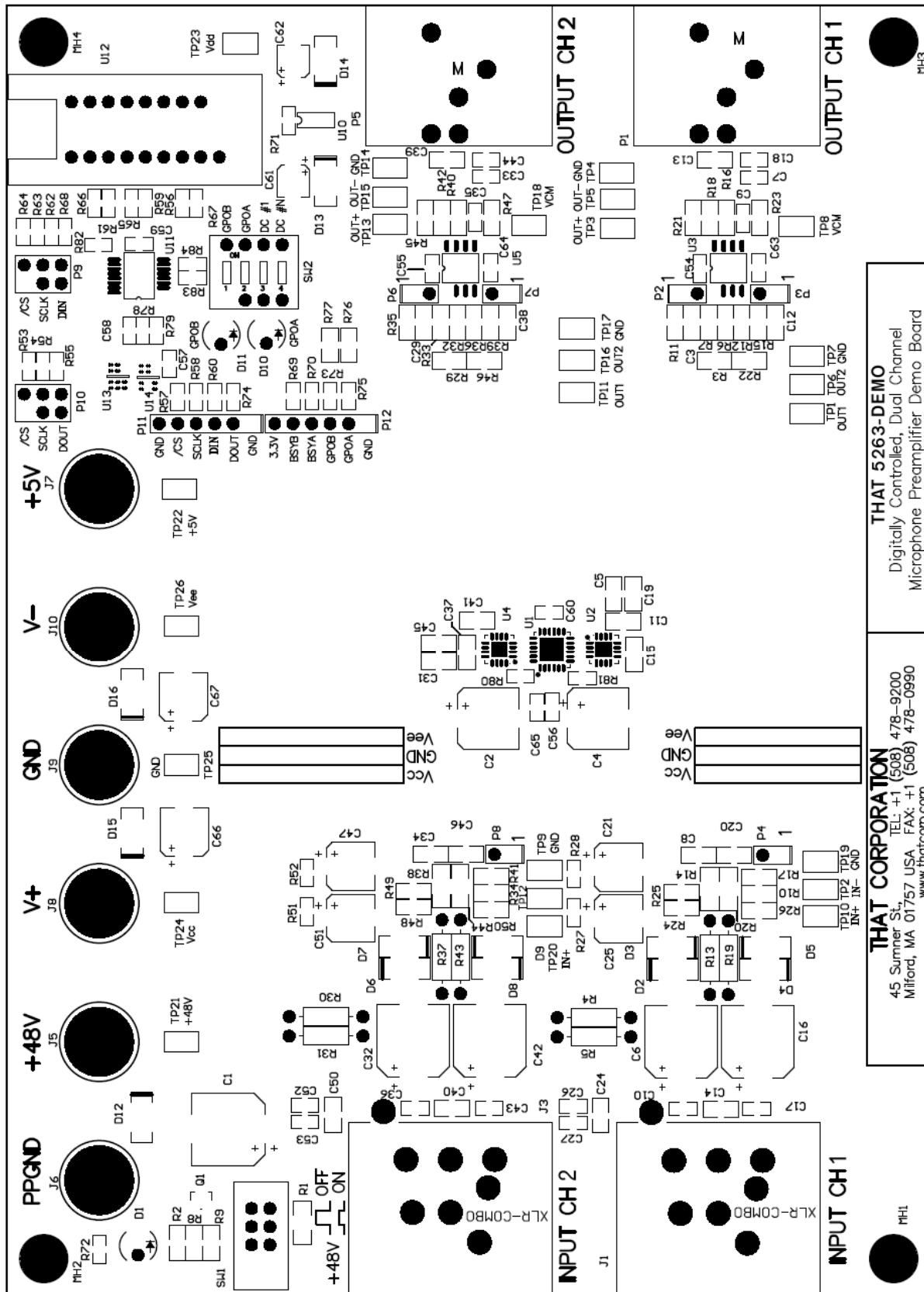

**THAT 5263-DEMO**  
Digitally Controlled, Dual Channel  
Microphone Preamplifier Demo Board

**THAT CORPORATION**  
45 Summer St.,  
Milford, MA 01757 USA FAX: +1 (508) 478-0990  
www.thatcorp.com

**Appendix C. PCB Layout (2 of 3)**

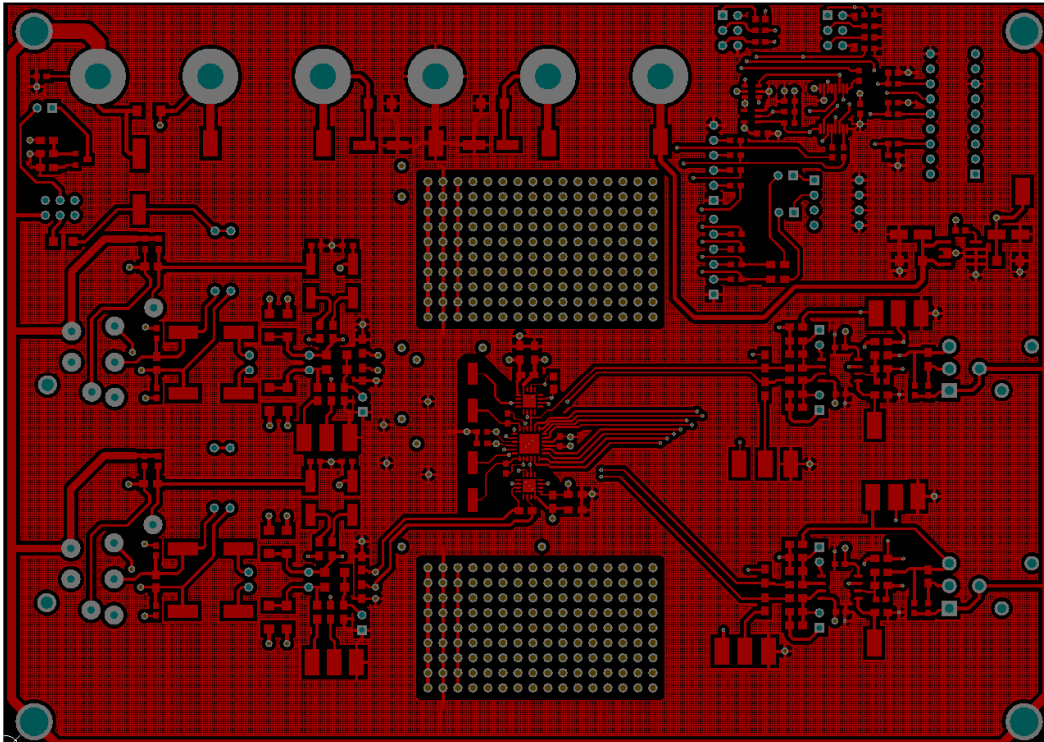

Layer 1 (Top)

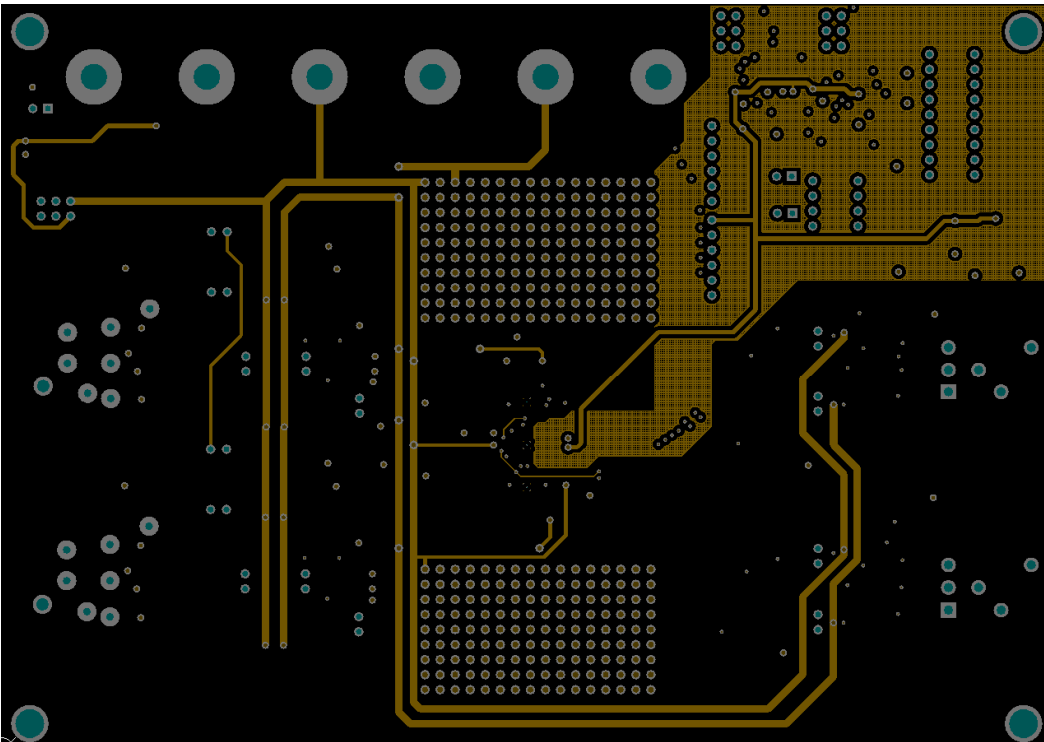

Layer 2 (Power)

### Appendix C. PCB Layout (3 of 3)

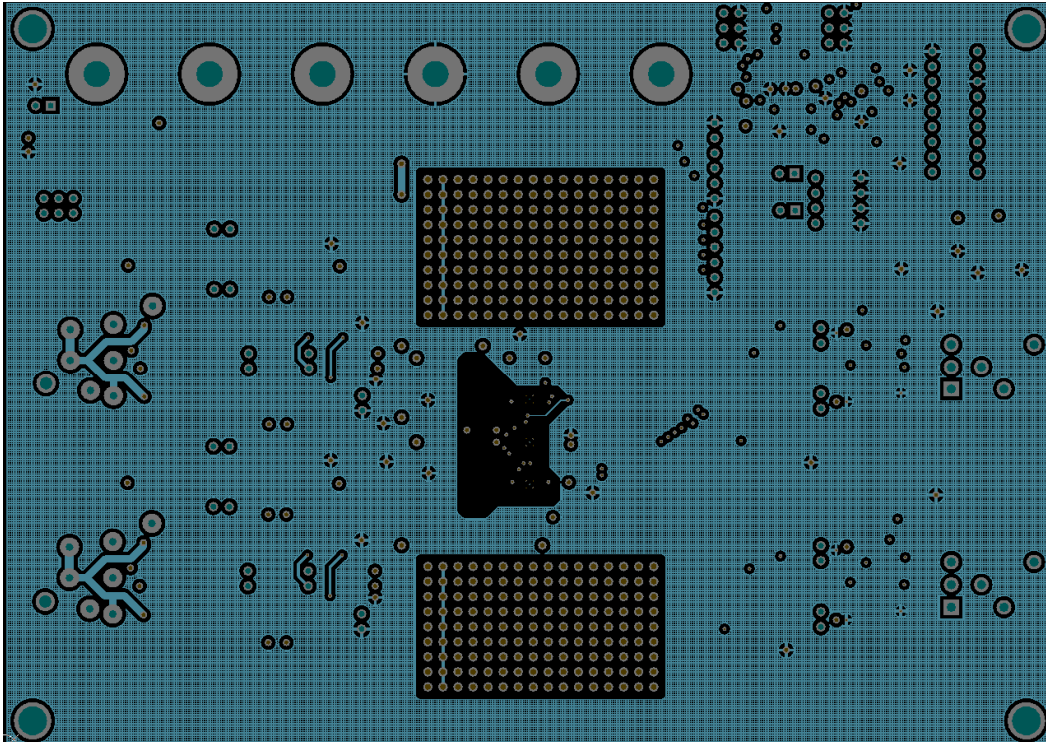

Layer 2 (Ground)

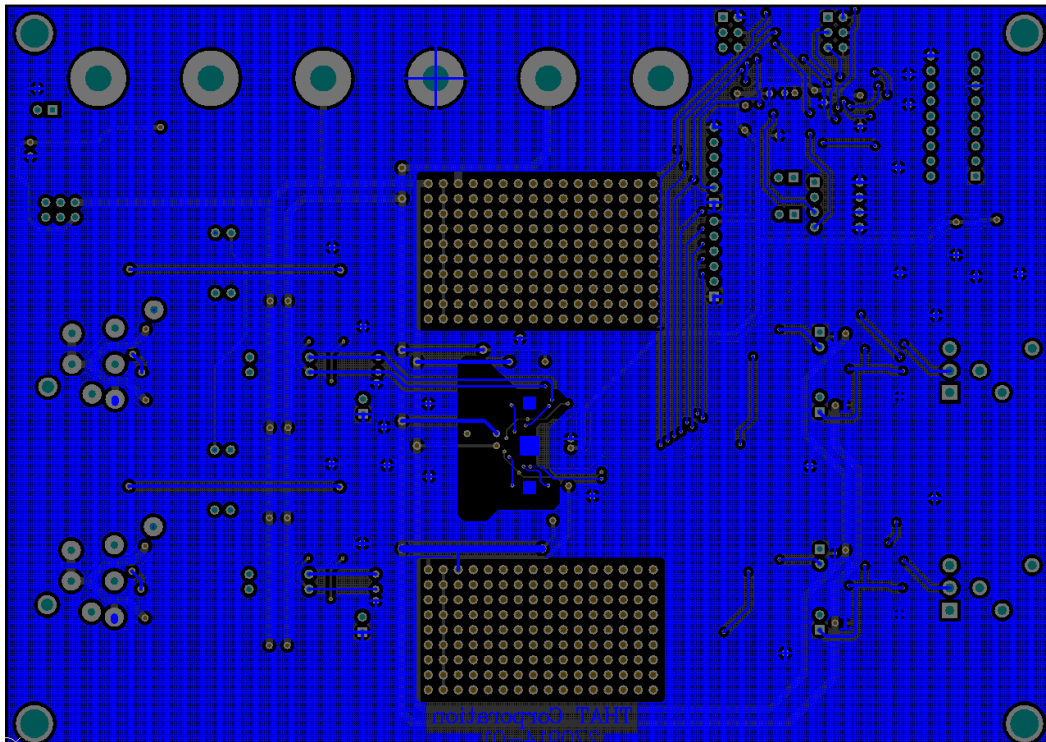

Layer 4 (Bottom)

**Appendix D. 5263 + 1583 Specifications<sup>1,2,3</sup>**

Parameter	Symbol	Typical	Units
Power Supply Voltage	V+ - V-	±15	V
Power Supply Current (per channel)	I(V+),I(V-) I(Vdd)	42 12 (All LEDs lit)	mA
Maximum Input Level (V+ /V- = ±15V)(1% THD)	V <sub>IN-BAL</sub>	+26.4	dBu
Maximum Differential Output Level (V+ /V- = ±15V)(1% THD)	V <sub>OUT</sub>	+28 (at 1583 output test points) +27 (at XLR outputs; limited by output driver)	dBu
Gain (input to output)	A <sub>dB</sub>	0 to 51 in 3dB steps	dB
Gain error (all settings)	A <sub>err</sub>	±0.3 (typical)	dB
Total Harmonic Distortion + N (f = 1kHz; BW = 22 kHz)	THD+N	0.0007 (0dB gain, V <sub>OUT</sub> = +10dBu) 0.0006 (+21dB gain, V <sub>OUT</sub> = +21dBu) 0.003 (+51dB gain, V <sub>OUT</sub> = +20dBu)	%
Equivalent Input Noise, Main Output (R <sub>SOURCE</sub> =150 Ω, BW=22kHz)	EIN	-126.2 (+51dB gain) -116 (+21dB gain) -95.5 (0dB gain)	dBu
Channel Separation (any combination of gain settings)		117 (1 kHz) 92 (20 kHz)	dB

1. All specifications are subject to change without notice.
2. Unless otherwise specified, T<sub>A</sub>=25°C, V<sub>CC</sub>=+15V, V<sub>EE</sub>=-15V, V<sub>DD</sub>=+3.3V
3. All audio specifications include the effects of the differential output buffer stage.

**Appendix E. 5263 + 1580 Specifications<sup>1,2,3</sup>**

Parameter	Symbol	Typical	Units
Power Supply Voltage	V+ - V-	±15	V
Power Supply Current (per channel)	I(V+),I(V-) I(Vdd)	42 12 (All LEDs lit)	mA
Maximum Input Level (V+ /V- = ±15V)(1% THD)	V <sub>IN-BAL</sub>	+26	dBu
Maximum Differential Output Level (V+ /V- = ±15V)(1% THD) (limited by the output driver)	V <sub>OUT</sub>	+28 (at 1580 output test points) +27 (at XLR outputs)	dBu
Gain (input to output)	A <sub>dB</sub>	0 to 51 in 3dB steps	dB
Gain error (all settings)	A <sub>err</sub>	±0.3 (typical)	dB
Total Harmonic Distortion + N (f = 1kHz; BW = 22 kHz)	THD+N	0.0004 (0dB gain, V <sub>OUT</sub> =+10dBu) 0.0004 (+21dB gain, V <sub>OUT</sub> =+21dBu) 0.002 (+51dB gain, V <sub>OUT</sub> =+20dBu)	%
Equivalent Input Noise, Main Output (R <sub>SOURCE</sub> =150 Ω, BW=22kHz)	EIN	-128 (+51dB gain) -119.5 (+21dB gain) -102.3 (0dB gain)(at 1580 output test points) -101.8 (at XLR output; limited by output driver)	dBu
Channel Separation (any combination of gain settings)		117 (1 kHz) 92 (20 kHz)	dB

1. All specifications are subject to change without notice.
2. Unless otherwise specified, T<sub>A</sub>=25°C, V<sub>CC</sub>=+15V, V<sub>EE</sub>=-15V, V<sub>DD</sub>=+3.3V
3. All audio specifications include the effects of the differential output buffer stage.

**FCC Warning**

This device is only intended for laboratory test environments. It may radiate radio frequency energy and has not been tested for compliance with subpart J of part 15

of the FCC regulations. Operation of this device in other environments may cause interference with radio communications.

**Revision History**

<b>Revision</b>	<b>ECO</b>	<b>Date</b>	<b>Changes</b>	<b>Page</b>
00	—	10/28/15	Initial Release	—
01	2986	10/27/16	Minor corrections to the specs in Appendix D and E	13, 14



# Mouser Electronics

Authorized Distributor

Click to View Pricing, Inventory, Delivery & Lifecycle Information:

[THAT Corporation:](#)

[158X/5263-DEMO](#)