

TCA9617A Level-Translating FM+ I²C Bus Repeater

1 Features

- Two-Channel Bidirectional I²C Buffer
- Support for Standard Mode, Fast Mode (400 kHz), and Fast Mode+ (1 Mhz) I²C Operation
- Operating Supply Voltage Range of 0.8 V to 5.5 V on A-Side
- Operating Supply Voltage Range of 2.2 V to 5.5 V on B-Side
- Voltage-Level Translation From 0.8 V to 5.5 V and 2.2 V to 5.5 V
- Footprint and Function Replacement for TCA9517
- Active-High Repeater-Enable Input
- Open-Drain I²C I/O
- 5.5-V Tolerant I²C and Enable Input Support
- Mixed-Mode Signal Operation
- Lockup-Free Operation
- Support for Clock Stretching and Multiple Master Arbitration Across The Device
- Latch-Up Performance Exceeds 100 mA Per JESD 78, Class II
- ESD Protection Exceeds JESD 22
 - 4000-V Human-Body Model (A114-A)
 - 1500-V Charged-Device Model (C101)

2 Applications

- Servers
- Routers (Telecom Switching Equipment)
- Industrial Equipment
- Products With Many I²C Slaves and/or Long PCB Traces

3 Description

The TCA9617A is a BiCMOS dual bidirectional buffer intended for I²C bus and SMBus systems. It can provide bidirectional voltage-level translation (up-translation and down-translation) between low voltages (down to 0.8 V) and higher voltages (2.2 V to 5.5 V) in mixed-mode applications. This device enables I²C and similar bus systems to be extended, without degradation of performance even during level shifting.

The TCA9617A buffers both the serial data (SDA) and the serial clock (SCL) signals on the I²C bus, allowing two buses of 550-pF or greater bus capacitance to be connected in an I²C application. This device can also be used to isolate two halves of a bus for voltage and capacitance.

Device Information⁽¹⁾

PART NUMBER	PACKAGE	BODY SIZE (NOM)
TCA9617A	VSSOP (8)	3.00 mm x 3.00 mm

(1) For all available packages, see the orderable addendum at the end of the datasheet.

4 Simplified Schematic

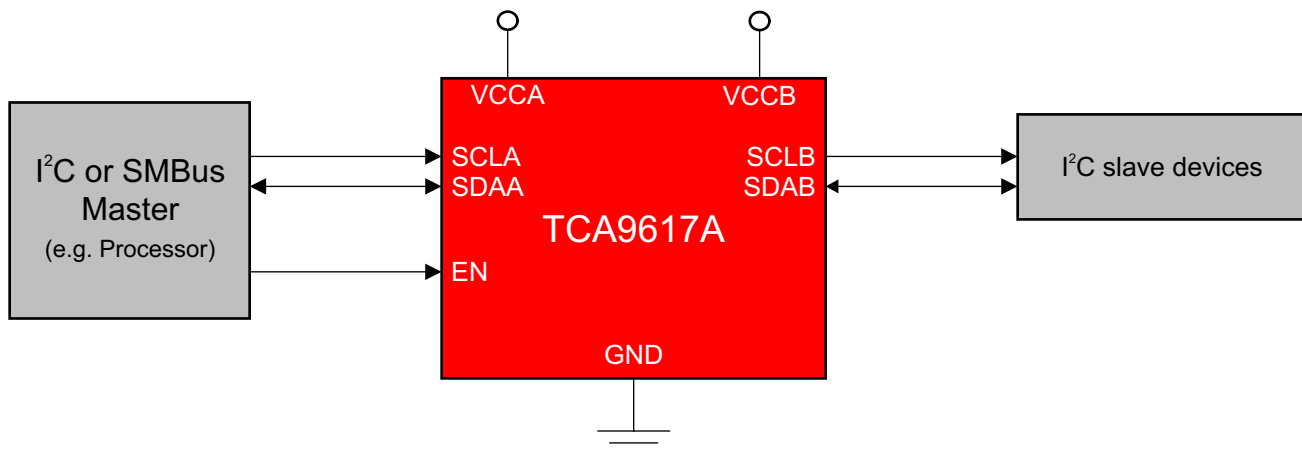

Table of Contents

1 Features	1	9.1 Overview	9
2 Applications	1	9.2 Functional Block Diagram	10
3 Description	1	9.3 Feature Description	10
4 Simplified Schematic	1	9.4 Device Functional Modes	11
5 Revision History	2	10 Application and Implementation	12
6 Pin Configuration and Functions	3	10.1 Application Information	12
7 Specifications	3	10.2 Typical Application	12
7.1 Absolute Maximum Ratings	3	11 Power Supply Recommendations	15
7.2 Handling Ratings	3	12 Layout	16
7.3 Recommended Operating Conditions	4	12.1 Layout Guidelines	16
7.4 Thermal Information	4	12.2 Layout Example	16
7.5 Electrical Characteristics	5	13 Device and Documentation Support	17
7.6 Timing Requirements	6	13.1 Trademarks	17
7.7 Typical Characteristics	6	13.2 Electrostatic Discharge Caution	17
8 Parameter Measurement Information	7	13.3 Glossary	17
9 Detailed Description	9	14 Mechanical, Packaging, and Orderable Information	17

5 Revision History

Changes from Original (June 2013) to Revision A

Page

• Deleted " Powered-Off High-Impedance I ² C Pins" from Features list	1
• Added Applications.	1
• Added Handling Ratings table.	3
• Added Thermal Information table.	4
• Added Typical Characteristics section.	6
• Added Detailed Description section.	9
• Added Application and Implementation section.	12
• Added Power Supply Recommendations section.	15
• Added Layout section.	16

6 Pin Configuration and Functions

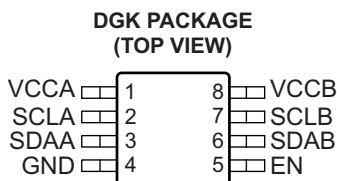

Pin Functions

PIN		DESCRIPTION
NAME	NO.	
EN	5	Active-high repeater enable input
GND	4	Supply ground
SCLA	2	I ² C SCL line, A side. Connect to V _{CCA} through a pull-up resistor.
SCLB	7	I ² C SCL line, B side. Connect to V _{CCB} through a pull-up resistor.
SDAA	3	I ² C SDA line, A side. Connect to V _{CCA} through a pull-up resistor.
SDAB	6	I ² C SDA line, B side. Connect to V _{CCB} through a pull-up resistor.
VCCA	1	A-side supply voltage (0.8 V to 5.5 V)
VCCB	8	B-side and device supply voltage (2.2 V to 5.5 V)

7 Specifications

7.1 Absolute Maximum Ratings⁽¹⁾

over operating free-air temperature range (unless otherwise noted)

		MIN	MAX	UNIT
V _{CCB}	Supply voltage range	-0.5	7	V
V _{CCA}	Supply voltage range	-0.5	7	V
V _I	Enable input voltage range ⁽²⁾	-0.5	7	V
V _{I/O}	I ² C bus voltage range ⁽²⁾	-0.5	7	V
I _{IK}	Input clamp current		-50	mA
I _{OK}	Output clamp current		-50	
I _O	Continuous output current		±50	mA
	Continuous current through V _{CC} or GND		±100	

(1) Stresses beyond those listed under "absolute maximum ratings" may cause permanent damage to the device. These are stress ratings only, and functional operation of the device at these or any other conditions beyond those indicated under "recommended operating conditions" is not implied. Exposure to absolute-maximum-rated conditions for extended periods may affect device reliability.

(2) The input negative-voltage and output voltage ratings may be exceeded if the input and output current ratings are observed.

7.2 Handling Ratings

		MIN	MAX	UNIT	
T _{stg}	Storage temperature range	-65	150	°C	
V _{ESD}	Electrostatic discharge	Human body model (HBM), per ANSI/ESDA/JEDEC JS-001, all pins ⁽¹⁾	0	4000	V
		Charged device model (CDM), per JEDEC specification JESD22-C101, all pins ⁽²⁾	0	1500	

(1) JEDEC document JEP155 states that 500-V HBM allows safe manufacturing with a standard ESD control process.

(2) JEDEC document JEP157 states that 250-V CDM allows safe manufacturing with a standard ESD control process.

7.3 Recommended Operating Conditions

over operating free-air temperature range (unless otherwise noted)

		MIN	MAX	UNIT
V _{CCA}	Supply voltage, A-side bus	0.8	V _{CCB}	V
V _{CCB}	Supply voltage, B-side bus	2.2	5.5	V
I _{OLA}	Low-level output current		30	mA
I _{OLB}	Low-level output current	0.1	30	mA
T _A	Operating free-air temperature	–40	85	°C

7.4 Thermal Information

THERMAL METRIC ⁽¹⁾		TCA9617A		UNIT
		DGK		
		8 PINS		
R _{θJA}	Junction-to-ambient thermal resistance	171.8		°C/W
R _{θJC(top)}	Junction-to-case (top) thermal resistance	61.2		
R _{θJB}	Junction-to-board thermal resistance	93.6		
ψ _{JT}	Junction-to-top characterization parameter	7.9		
ψ _{JB}	Junction-to-board characterization parameter	91.9		

 (1) For more information about traditional and new thermal metrics, see the *IC Package Thermal Metrics* application report, [SPRA953](http://www.ti.com/lit/zip/Spra953).

7.5 Electrical Characteristics

 $V_{CCB} = 2.2\text{ V to }5.5\text{ V}$, $GND = 0\text{ V}$, $T_A = -40^\circ\text{C to }85^\circ\text{C}$ (unless otherwise noted)

PARAMETER		TEST CONDITIONS	V_{CCB}	MIN	TYP	MAX	UNIT
V_{IK}	Input clamp voltage	$I_I = -18\text{ mA}$	2.2 V to 5.5 V			-1.2	V
V_{OL}	Low-level output voltage	SDAB, SCLB $I_{OL} = 100\mu\text{A}$ or 30mA , $V_{ILA} = 0\text{ V}$	2.2 V to 5.5 V	0.48	0.53	0.58	V
		SDAA, SCLA $I_{OL} = 30\text{mA}$			0.1	0.2	
V_{IH}	High-level input voltage	SDAA, SCLA	2.2 V to 5.5 V	$0.7 \times V_{CCA}$		V_{CCB}	V
		SDAB, SCLB		$0.7 \times V_{CCB}$		V_{CCB}	
		EN		$0.7 \times V_{CCB}$		5.5	
V_{IL}	Low-level input voltage	SDAA, SCLA	2.2 V to 5.5 V			$0.3 \times V_{CCA}$	V
		SDAB, SCLB				0.4	
		EN				$0.3 \times V_{CCB}$	
I_{CCA}	Quiescent supply current for V_{CCA}	Both channels low, SDAA = SCLA = GND and SDAB = SCLB = open, or SDAA = SCLA = open and SDAB = SCLB = GND	2.2 V to 5.5 V			13	μA
I_{CCB}	Quiescent supply current	Both Channels high, SDAA = SCLA = V_{CCA} B-side pulled up to V_{CCB} with pullup resistors	5.5 V		+4.5	+7	mA
		Both channels low, SDAA = SCLA = GND, $I_{OLB} = 100\ \mu\text{A}$			+5.7	+8.1	
I_I	Input leakage current	SDAB, SCLB	2.2 V to 5.5 V	$V_I = V_{CCB}$		+1	μA
				$V_I = 0.2\text{ V}$, EN = 0	-10	+10	
				$V_I = V_{CCB} - 0.2\text{ V}$	-1	+1	
		SDAA, SCLA		$V_I = V_{CCA}$	-1	+1	
				$V_I = 0.2\text{ V}$	-10	+10	
				$V_I = V_{CCA} - 0.2\text{ V}$	-1	+1	
		EN		$V_I = V_{CCB}$	-1	+1	
$V_I = 0.2\text{ V}$	-25						
C_I	Input capacitance	EN	$V_I = 3\text{ V}$ or 0 V	3.3 V		7	pF
		SCLA, SCLB	$V_I = 3\text{ V}$ or 0 V	3.3 V		9	
			$V_I = 0\text{ V}$			9	
C_I	Input/output capacitance	SDAA, SDAB	$V_I = 3\text{ V}$ or 0 V	3.3 V		14	pF
			$V_I = 0\text{ V}$			14	

7.6 Timing Requirements

$V_{CCA} = 0.8\text{ V to }5.5\text{ V}$, $V_{CCB} = 2.2\text{ V to }5.5\text{ V}$, $GND = 0\text{ V}$, $T_A = -40^\circ\text{C to }85^\circ$ (unless otherwise noted)⁽¹⁾⁽²⁾

PARAMETER		FROM (INPUT)	TO (OUTPUT)	TEST CONDITIONS	MIN	TYP ⁽³⁾	MAX	UNIT
t_{PLH}	Propagation delay	SDAB, SCLB	SDAA, SCLA		42	55	90	ns
		SDAA, SCLA	SDAB, SCLB	$V_{CCB} \leq 3\text{ V}$	61	88	137	
				$V_{CCB} > 3\text{ V}$	61	94	250	
t_{PHL}	Propagation delay	SDAB, SCLB	SDAA, SCLA		69	93	144	ns
		SDAA, SCLA	SDAB, SCLB		68	90	140	
$t_{TLH}^{(4)}$	Transition time	B side	30%	70%				ns
		A side			88			
t_{THL}	Transition time	B side	70%	30%	5.40	6.41	13.8	ns
		A side			1.40	4.71	11.3	
t_{su}	Setup time, EN high before Start condition ⁽⁵⁾				100			ns

- (1) Times are specified with loads of $240\ \Omega \pm 1\%$ and $400\text{ pF} \pm 10\%$ on B-side and $240\ \Omega \pm 1\%$ and $200\text{ pF} \pm 10\%$ on A-side. Different load resistance and capacitance alter the rise time, thereby changing the propagation delay and transition times.
- (2) Times are specified with A-side signals pulled up to V_{CCA} ; $V_{CCA} = 0.9\text{ V}$ and B-side signals pulled up to V_{CCB} ; $V_{CCB} = 2.5\text{ V}$.
- (3) Typical values were measured with $V_{CCA} = 0.9\text{ V}$ and $V_{CCB} = 2.5\text{ V}$ at $T_A = 25^\circ\text{C}$, unless otherwise noted.
- (4) t_{TLH} is determined by the pullup resistance and load capacitance.
- (5) EN should change state only when the global bus and the repeater port are in an idle state.

7.7 Typical Characteristics

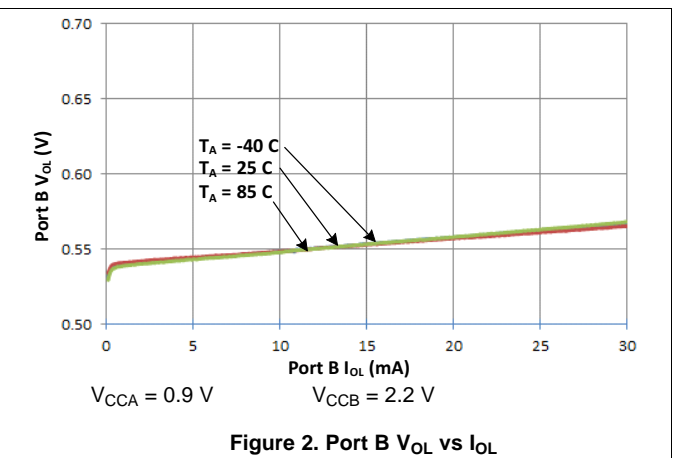
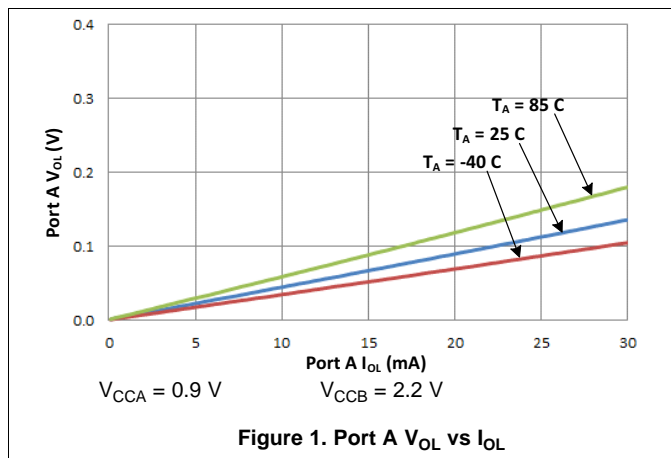

8 Parameter Measurement Information

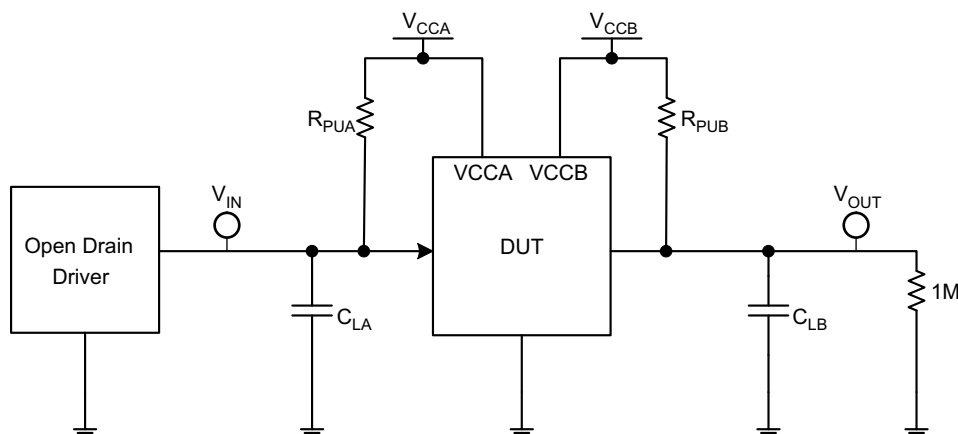
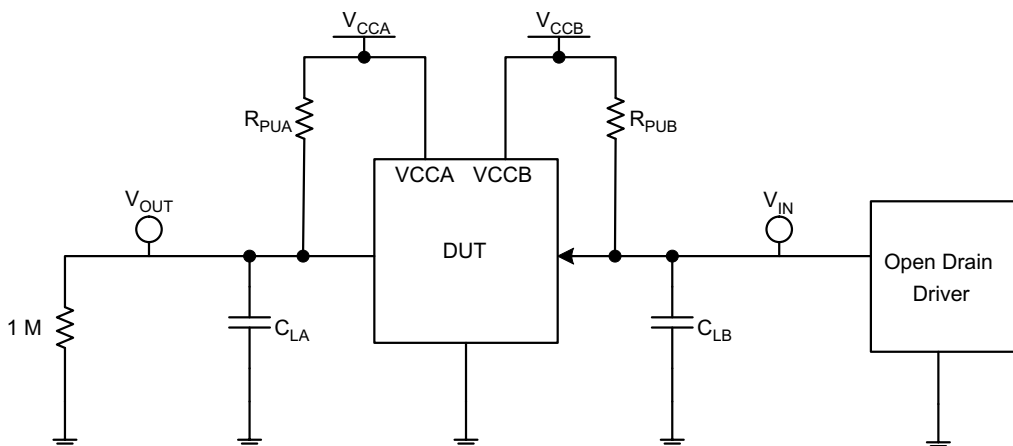

Figure 3. Test Circuit for Open-Drain Output from A to B



- A. $V_{CCA} = 0.9 \text{ V}$
- B. $V_{CCB} = 2.5 \text{ V}$
- C. $R_{PUA} = R_{PUB} = 240 \Omega$ on the A-side and the B-side
- D. $C_{LA} = 200 \text{ pF}$ on A-side and $C_{LB} = 400 \text{ pF}$ on B-side (includes probe and jig capacitance)
- E. All input pulses are supplied by generators having the following characteristics: $PRR \leq 10 \text{ MHz}$, $Z_O = 50 \Omega$, slew rate $\geq 1 \text{ V/ns}$
- F. The outputs are measured one at a time, with one transition per measurement.

Figure 4. Test Circuit for Open-Drain Output from B to A

Parameter Measurement Information (continued)

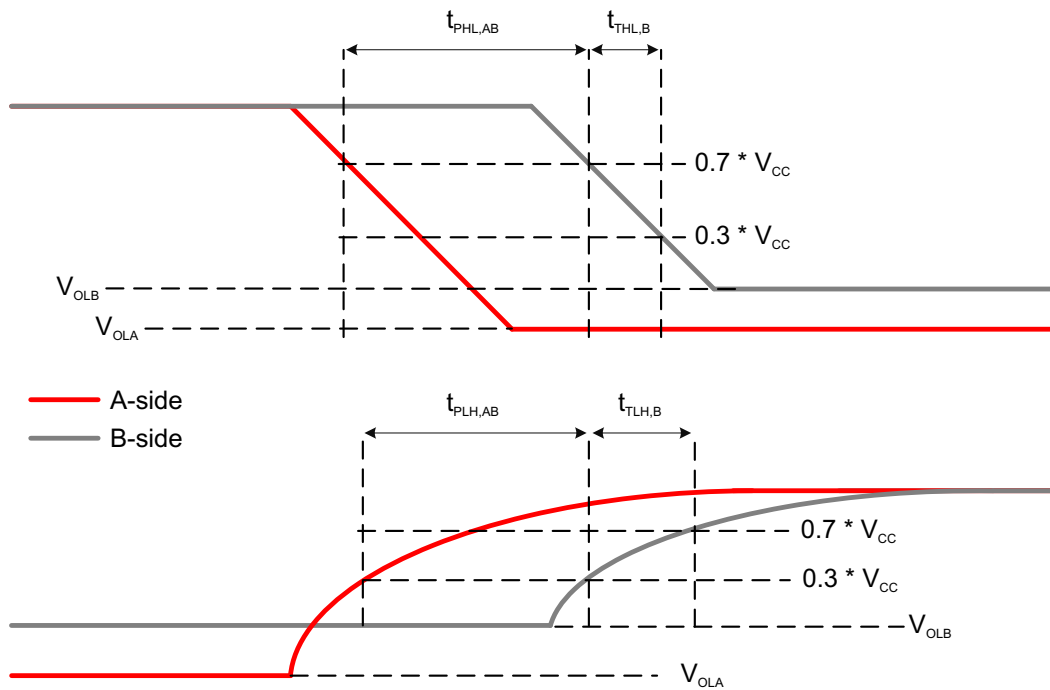

Figure 5. Propagation Delay And Transition Times (A to B)

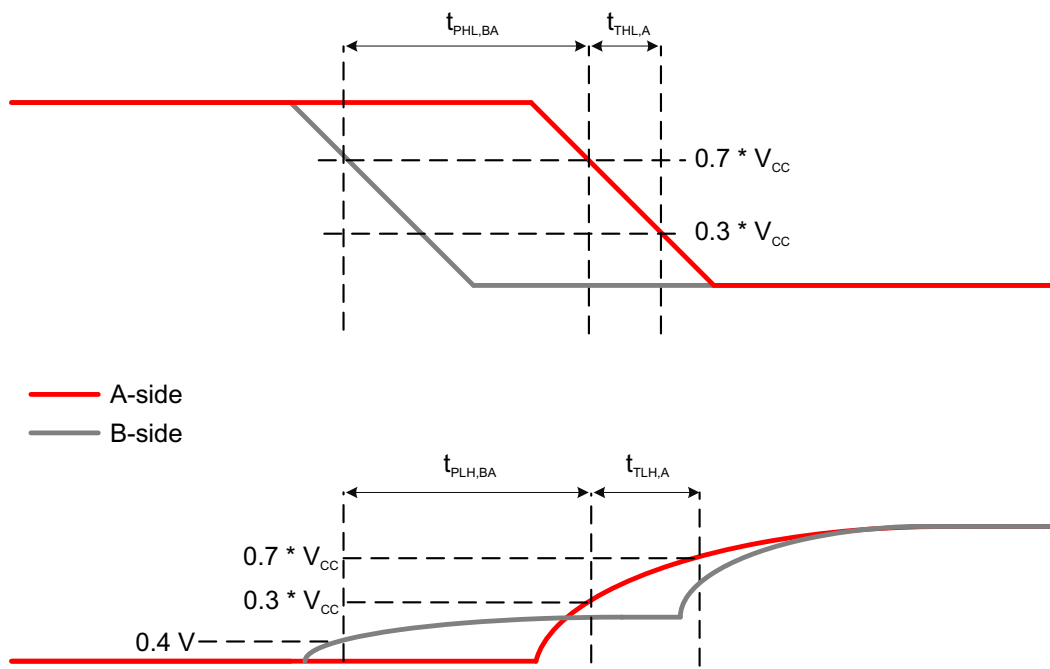

Figure 6. Propagation Delay And Transition Times (B to A)

9 Detailed Description

9.1 Overview

The TCA9617A is a BiCMOS dual bidirectional buffer intended for I²C bus and SMBus systems. As with the standard I²C system, pullup resistors are required to provide the logic high levels on the buffered bus. The TCA9617A has standard open-drain configuration of the I²C bus. The size of these pullup resistors depends on the system, but each side of the repeater must have a pullup resistor. The device is designed to work with Standard mode, Fast mode and Fast Mode+ I²C devices.

The TCA9617A B-side drivers operate from 2.2 V to 5.5 V. The output low level for this internal buffer is approximately 0.5 V, but the input voltage must be 70 mV or more below the output low level when the output is externally driven low. The higher-voltage low signal is called a buffered low. When the B-side I/O is driven low internally, the low is not recognized as a low by the input. This feature prevents a lockup condition from occurring when the input low condition is released. This type of design on the B side prevents it from being used in series with another TCA9617A B-side or other buffers that incorporate a static or dynamic offset voltage. This is because these devices do not recognize buffered low signals as a valid low and do not propagate it as a buffered low again.

The TCA9617A A-side drivers operate from 0.8 V to 5.5 V and do not have the buffered low feature (or the static offset voltage). This means that a low signal on the B side translates to a nearly 0-V low on the A side, which accommodates smaller voltage swings of low-voltage logic. The output pulldown on the A side drives a hard low, and the input level is set to 0.3 V_{CCA} to accommodate the need for a lower low level in systems where the low-voltage-side supply voltage is as low as 0.8 V.

The A side of two or more TCA9617As can be connected together to allow a star topology, with the A side on the common bus. Also, the A side can be connected directly to any other buffer with static or dynamic offset voltage. Multiple TCA9617As can be connected in series, A side to B side, with no buildup in offset voltage with only time-of-flight delays to consider.

The TCA9617A includes a power-up circuit that keeps the output drivers turned off until V_{CCB} is above 2.0 V and V_{CCA} is above 0.7 V. V_{CCA} is only used to provide references for the A-side input comparators and the power-good-detect circuit. The TCA9617A internal circuitry and all I/Os are powered by the V_{CCB} pin; however, due to ESD protection requirements on the SCLA and SDAA, it is required to power-up V_{CCB} prior to V_{CCA}. If SDA and SCL (on A-side or B-side) are pulled up to a positive voltage before V_{CCB} is powered, there can be significant current leakage into the SCA and SCL pins that could cause them to be pulled down. The SDA and SCL lines shall not be pulled up to a voltage higher than V_{CCB}, even when the device is powered down.

After power up and with the EN high, the A side falling below 0.7 V_{CCA} turns on the corresponding B-side driver (either SDA or SCL) and drives the B-side down momentarily to 0 V before settling to approximately 0.5 V. When the A-side rises above 0.3 V_{CCA}, the B-side pulldown driver is turned off and the external pullup resistor pulls the pin high. If the B side falls first and goes below 0.7 V_{CCB}, the A-side driver is turned on and drives the A-side to 0 V. When the B-side rises above 0.45 V, the A-side pulldown driver is turned off and the external pullup resistor pulls the pin high.

9.2 Functional Block Diagram

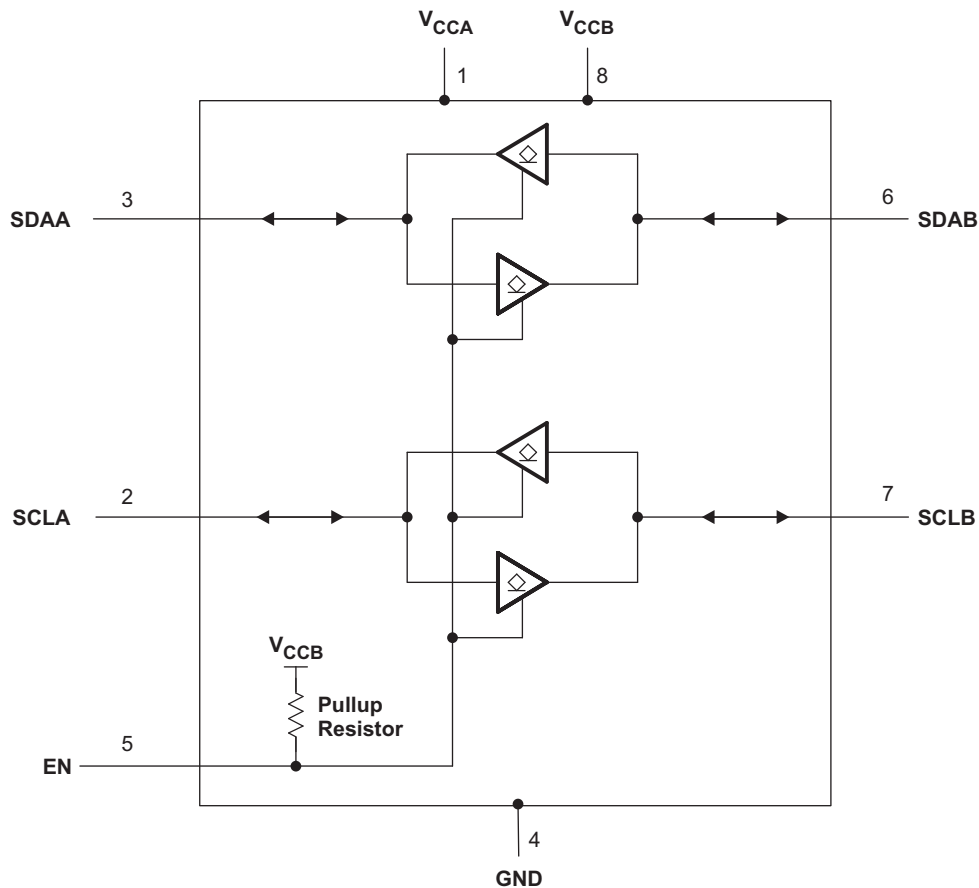

9.3 Feature Description

9.3.1 Bidirectional Level Translation

The TCA9617A can provide bidirectional voltage level translation (up-translation and down-translation) between low voltages (down to 0.8 V) and higher voltages (2.2 V to 5.5 V) in mixed-mode applications.

9.3.2 V_{OL} B-side Offset Voltage

[Figure 8](#) depicts the offset voltage on the B side of the device. As shown in [Figure 8](#) the slave releases and the B-side rises, and it will rise to 0.5 V and stay there until the A-side rises above $0.3 V_{CCA}$. This effect can cause the low level signal to have a "pedestal." Once the voltage on the A-side crosses $0.3 V_{CCA}$, the B-side will continue to rise to V_{CCB} .

Due to nature of the B-side pedestal and the static offset voltage, there will be a slight overshoot (point 2) as the B-side rises from being externally driven low to the 0.5 V offset. The TCA9617A is designed to control this behavior provided the system is designed with rise times greater than 20 ns. Therefore, care should be taken to limit the pullup strength when devices with rise time accelerators are present on the B side. Excessive overshoot on the B-side pedestal may cause devices with rise time accelerators to trip prematurely if the accelerator thresholds are below $0.3 V_{CCB}$. Since the A-side does not have a static offset low voltage, no pedestal is seen on the A-side as shown in [Figure 7](#).

Feature Description (continued)

9.3.3 High to Low Transition Characteristics

When the A side of the bus is driven to $0.7 V_{CCA}$, the B side driver will turn on. This will drive the B-side to 0 V for a short period (see Figure 8) and then the B-side will rise to the static offset voltage of 0.5 V (V_{OL} of TCA9617A). This effect, called an inverted pedestal, allows the B-side to drive to logic low much faster than driving to the static offset. Driving to the static offset voltage requires that the fall time be slowed to prevent ringing.

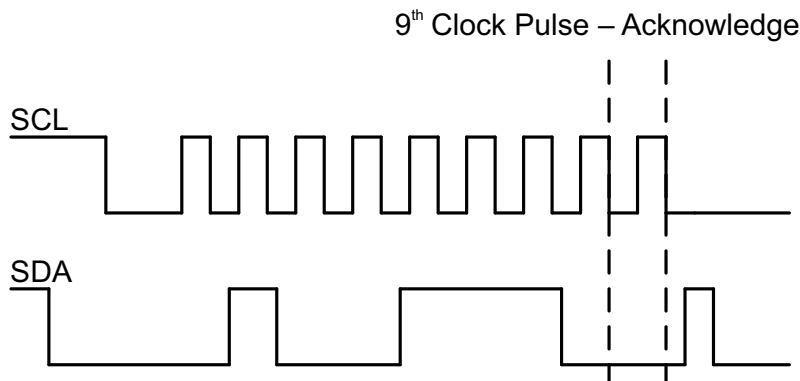

Figure 7. Bus A (0.8 V to 5.5 V Bus) Waveform

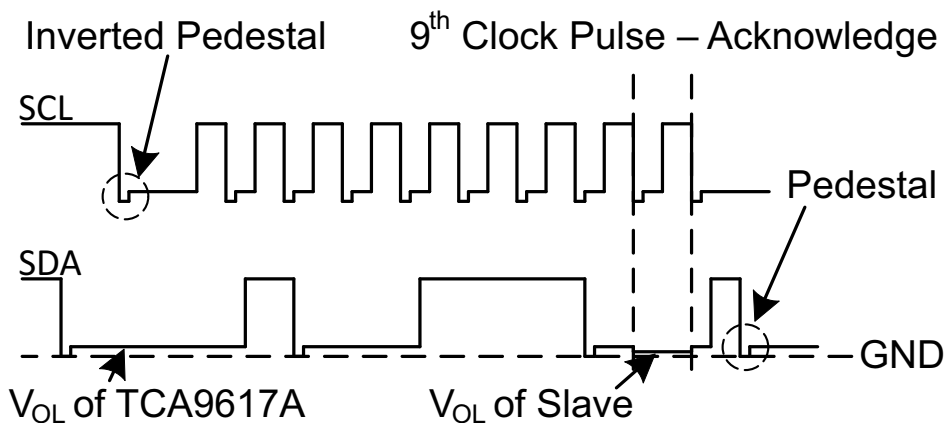

Figure 8. Bus B (2.2 V to 5.5 V Bus) Waveform

9.4 Device Functional Modes

The TCA9617A has an active-high enable (EN) input with an internal pull-up to V_{CCB} , which allows the user to select when the repeater is active. This can be used to isolate a badly behaved slave on power-up reset. It should never change state during an I²C operation, because disabling during a bus operation may hang the bus, and enabling part way through the bus cycles could confuse the I²C parts being enabled. The EN input should change state only when the global bus and repeater port are in the idle state to prevent system failures.

Table 1. Function Table

INPUT EN	FUNCTION
L	Outputs disabled
H	SDAA = SDAB SCLA = SCLB

10 Application and Implementation

10.1 Application Information

A typical application is shown in [Figure 9](#). In this example, the system master is running on a 0.9-V I²C bus, and the slave is connected to a 2.5-V bus. Both buses are running at 400 kHz. Decoupling capacitors are required but are not shown in [Figure 14](#) for simplicity.

The TCA9617A is 5-V tolerant so no additional circuits are required to translate between 0.8-V to 5.5-V bus voltages and 2.7-V to 5.5-V bus voltages.

When the A side of the TCA9617A is pulled low by a driver on the I²C bus, a comparator detects the falling edge when it goes below 0.7 V_{CCA} and cause the internal driver on the B side to turn on. The B-side will first pull down to 0 V and then settle to 0.5 V. When the B side of the TCA9617A falls below 0.45 V, the TCA9617A will detect the falling edge, turn on the internal driver on the A side and pull the A-side pin down to ground. In order to illustrate what would be seen for an A to B transition refer to [Figure 11](#), and for a B to A transition see [Figure 10](#).

On the B-side bus of the TCA9617A, the clock and data lines will have a positive offset from ground equal to the V_{OL} of the TCA9617A. After the eighth clock pulse, the data line is pulled to the V_{OL} of the slave device, which is close to ground in this example. At the end of the acknowledge, the level rises only to the low level set by the driver of the TCA9617A for a short delay (approximately 0.5 V), while the A-side bus rises above 0.3 V_{CCA} and then continues high.

Although the TCA9617 has a single application, the device can exist in multiple configurations. [Figure 9](#) shows the standard configuration for the TCA9617. Multiple TCA9617s can be connected either in star configuration ([Figure 12](#)) or in series configuration ([Figure 13](#)). The design requirements, detailed design procedure, and application curves in [Standard Application](#) are valid for all three configurations.

10.2 Typical Application

10.2.1 Standard Application

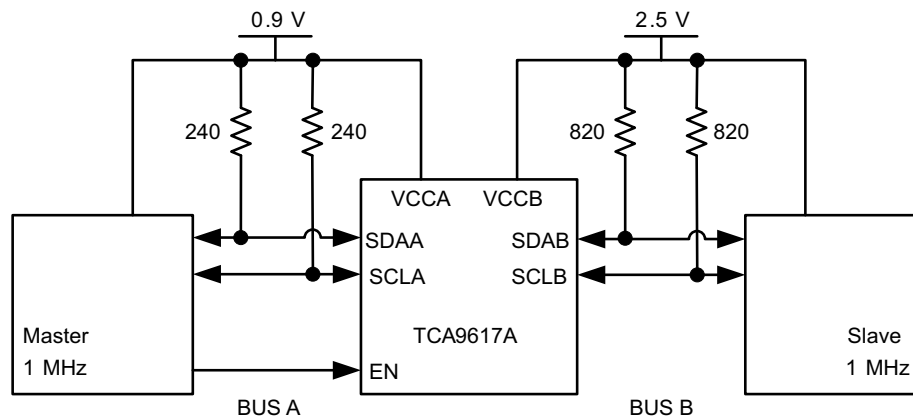

Figure 9. Bidirectional Voltage Level Translator

10.2.1.1 Design Requirements

For the level-translating application, the following should be true:

- V_{CCA} = 0.8 V to 5.5 V
- V_{CCB} = 2.2 V to 5.5 V
- V_{CCA} < V_{CCB}
- I_{OL} > I_O

Typical Application (continued)

10.2.1.2 Detailed Design Procedure

10.2.1.2.1 Pullup Resistor Sizing

For the TCA9617A to function correctly, all devices on the B-side must be able to pull the B-side below the voltage input low contention level (0.45 V). This means that the V_{OL} of any device on the B-side must be below 0.4 V to ensure proper operation.

The V_{OL} of a device can be adjusted by changing the I_{OL} through the device which is set by the pull-up resistor value. The pull-up resistor on the B-side must be carefully selected to ensure that logic levels will be transferred correctly to the A-side.

The B-side pull-up resistor sizing must also ensure that the rise time is greater than 20 ns. Shorter rise times will increase the pedestal overshoot shown in point 2 of [Figure 10](#).

10.2.1.3 Application Curves

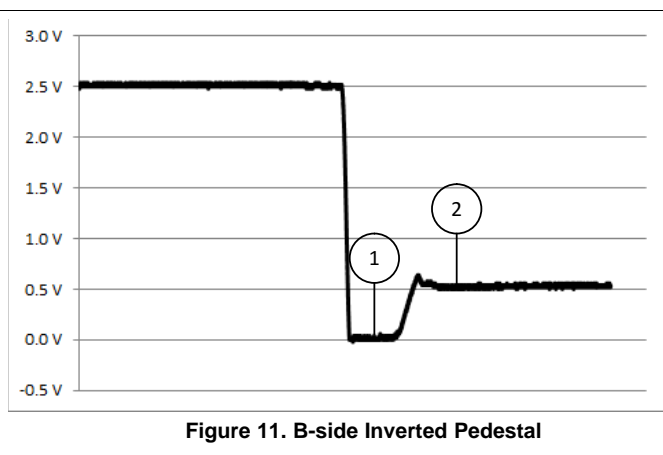
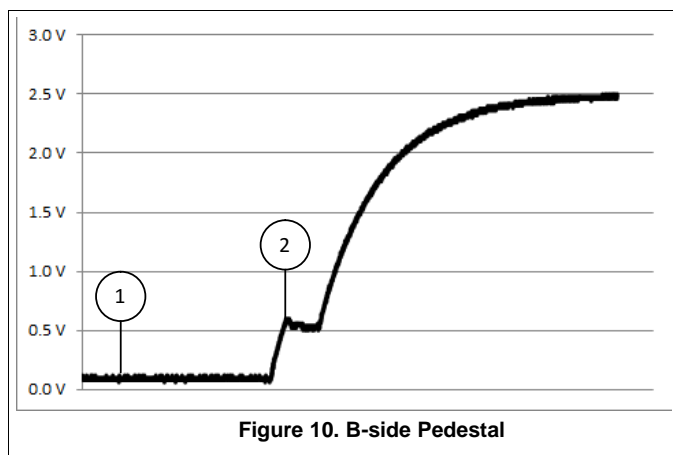

Typical Application (continued)

10.2.2 Star Application

Multiple TCA9617A A sides can be connected in a star configuration, allowing all nodes to communicate with each other.

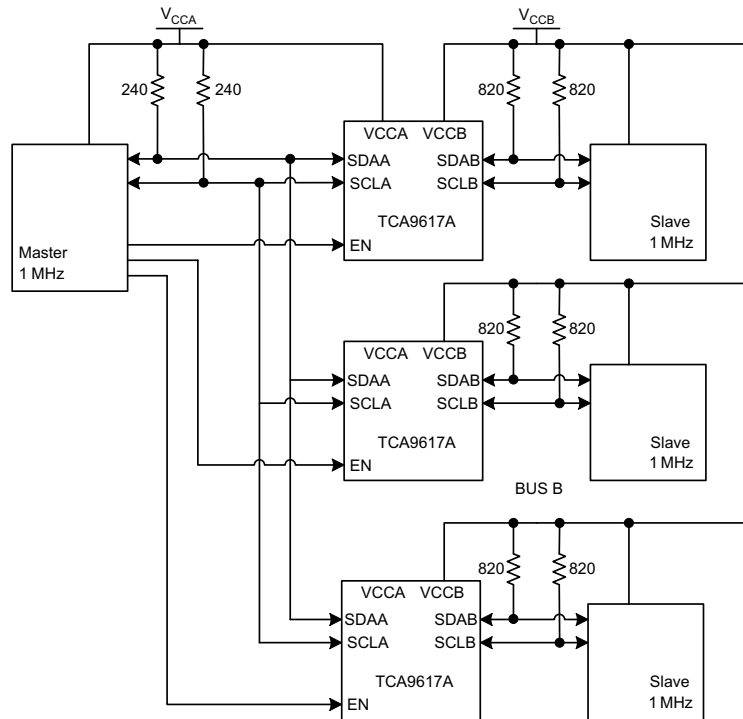

Figure 12. Typical Star Application

10.2.2.1 Design Requirements

Refer to [Design Requirements](#).

10.2.2.2 Detailed Design Procedure

Refer to [Detailed Design Procedure](#).

10.2.2.3 Application Curves

Refer to [Application Curves](#).

Typical Application (continued)

10.2.3 Series Application

Multiple TCA9617As can be connected in series as long as the A side is connected to the B side. I²C bus slave devices can be connected to any of the bus segments. The number of devices that can be connected in series is limited by repeater delay/time-of-flight considerations on the maximum bus speed requirements.

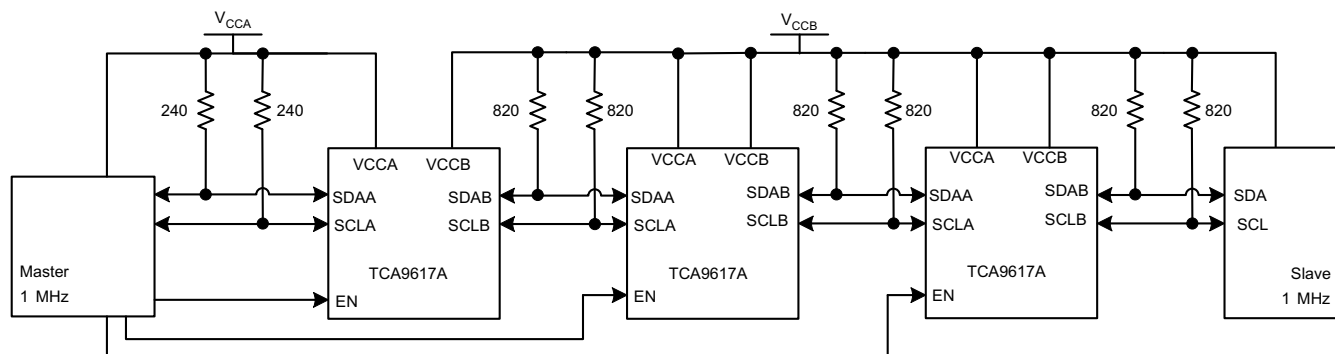

Figure 13. Typical Series Application

10.2.3.1 Design Requirements

Refer to [Design Requirements](#).

10.2.3.2 Detailed Design Procedure

Refer to [Detailed Design Procedure](#).

10.2.3.3 Application Curves

Refer to [Application Curves](#).

11 Power Supply Recommendations

For VCCA, an 0.8-V to 5.5-V power supply is required. For VCCB, a 2.2-V to 5.5-V power supply is required.

VCCB should always be higher than VCCA. VCCB cannot be lower than VCCA even when the device is disabled. During power-up, VCCB must rise before VCCA.

Standard decoupling capacitors are recommended. These capacitors typically range from 0.1 μF to 1 μF, but the ideal capacitance depends on the amount of noise from the power supply.

12 Layout

12.1 Layout Guidelines

The recommended decoupling capacitors should be placed as close to the V_{CCA} and V_{CCB} pins of the TCA9617A as possible.

12.2 Layout Example

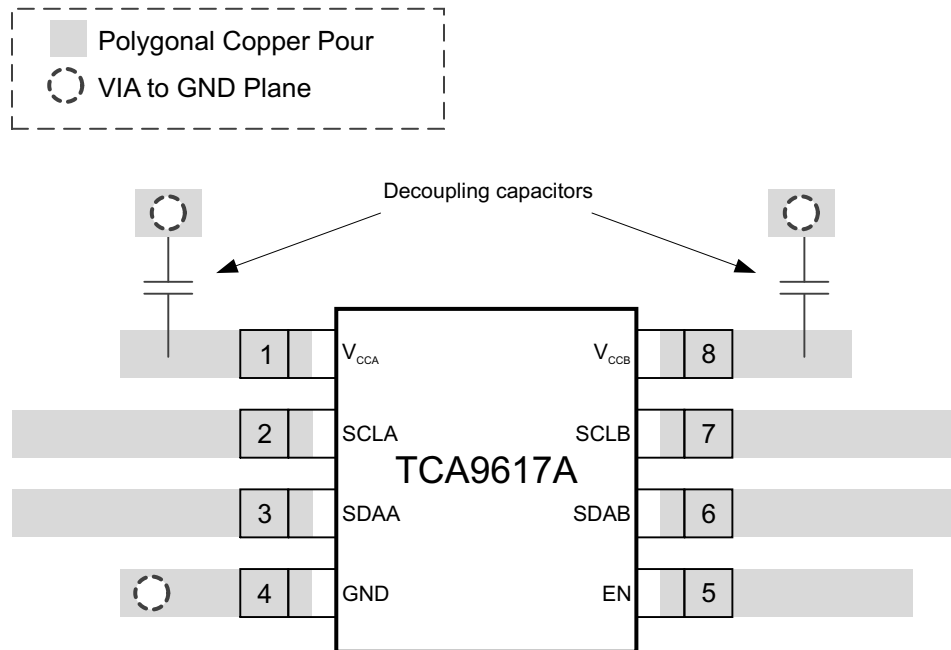

Figure 14. Layout Schematic

13 Device and Documentation Support

13.1 Trademarks

All trademarks are the property of their respective owners.

13.2 Electrostatic Discharge Caution



These devices have limited built-in ESD protection. The leads should be shorted together or the device placed in conductive foam during storage or handling to prevent electrostatic damage to the MOS gates.

13.3 Glossary

[SLYZ022](#) — *TI Glossary*.

This glossary lists and explains terms, acronyms, and definitions.

14 Mechanical, Packaging, and Orderable Information

The following pages include mechanical, packaging, and orderable information. This information is the most current data available for the designated devices. This data is subject to change without notice and revision of this document. For browser-based versions of this data sheet, refer to the left-hand navigation.

PACKAGING INFORMATION

Orderable Device	Status (1)	Package Type	Package Drawing	Pins	Package Qty	Eco Plan (2)	Lead/Ball Finish (6)	MSL Peak Temp (3)	Op Temp (°C)	Device Marking (4/5)	Samples
TCA9617ADGKR	ACTIVE	VSSOP	DGK	8	2500	Green (RoHS & no Sb/Br)	CU NIPDAU CU NIPDAUAG	Level-1-260C-UNLIM	-40 to 85	(7EA, DWK)	Samples

(1) The marketing status values are defined as follows:

ACTIVE: Product device recommended for new designs.

LIFEBUY: TI has announced that the device will be discontinued, and a lifetime-buy period is in effect.

NRND: Not recommended for new designs. Device is in production to support existing customers, but TI does not recommend using this part in a new design.

PREVIEW: Device has been announced but is not in production. Samples may or may not be available.

OBSOLETE: TI has discontinued the production of the device.

(2) **RoHS:** TI defines "RoHS" to mean semiconductor products that are compliant with the current EU RoHS requirements for all 10 RoHS substances, including the requirement that RoHS substance do not exceed 0.1% by weight in homogeneous materials. Where designed to be soldered at high temperatures, "RoHS" products are suitable for use in specified lead-free processes. TI may reference these types of products as "Pb-Free".

RoHS Exempt: TI defines "RoHS Exempt" to mean products that contain lead but are compliant with EU RoHS pursuant to a specific EU RoHS exemption.

Green: TI defines "Green" to mean the content of Chlorine (Cl) and Bromine (Br) based flame retardants meet JS709B low halogen requirements of <=1000ppm threshold. Antimony trioxide based flame retardants must also meet the <=1000ppm threshold requirement.

(3) MSL, Peak Temp. - The Moisture Sensitivity Level rating according to the JEDEC industry standard classifications, and peak solder temperature.

(4) There may be additional marking, which relates to the logo, the lot trace code information, or the environmental category on the device.

(5) Multiple Device Markings will be inside parentheses. Only one Device Marking contained in parentheses and separated by a "~" will appear on a device. If a line is indented then it is a continuation of the previous line and the two combined represent the entire Device Marking for that device.

(6) Lead/Ball Finish - Orderable Devices may have multiple material finish options. Finish options are separated by a vertical ruled line. Lead/Ball Finish values may wrap to two lines if the finish value exceeds the maximum column width.

Important Information and Disclaimer:The information provided on this page represents TI's knowledge and belief as of the date that it is provided. TI bases its knowledge and belief on information provided by third parties, and makes no representation or warranty as to the accuracy of such information. Efforts are underway to better integrate information from third parties. TI has taken and continues to take reasonable steps to provide representative and accurate information but may not have conducted destructive testing or chemical analysis on incoming materials and chemicals. TI and TI suppliers consider certain information to be proprietary, and thus CAS numbers and other limited information may not be available for release.

In no event shall TI's liability arising out of such information exceed the total purchase price of the TI part(s) at issue in this document sold by TI to Customer on an annual basis.

TAPE AND REEL INFORMATION



QUADRANT ASSIGNMENTS FOR PIN 1 ORIENTATION IN TAPE



*All dimensions are nominal

Device	Package Type	Package Drawing	Pins	SPQ	Reel Diameter (mm)	Reel Width W1 (mm)	A0 (mm)	B0 (mm)	K0 (mm)	P1 (mm)	W (mm)	Pin1 Quadrant
TCA9617ADGKR	VSSOP	DGK	8	2500	330.0	12.4	5.3	3.4	1.4	8.0	12.0	Q1

TAPE AND REEL BOX DIMENSIONS



*All dimensions are nominal

Device	Package Type	Package Drawing	Pins	SPQ	Length (mm)	Width (mm)	Height (mm)
TCA9617ADGKR	VSSOP	DGK	8	2500	364.0	364.0	27.0

DGK (S-PDSO-G8)

PLASTIC SMALL-OUTLINE PACKAGE

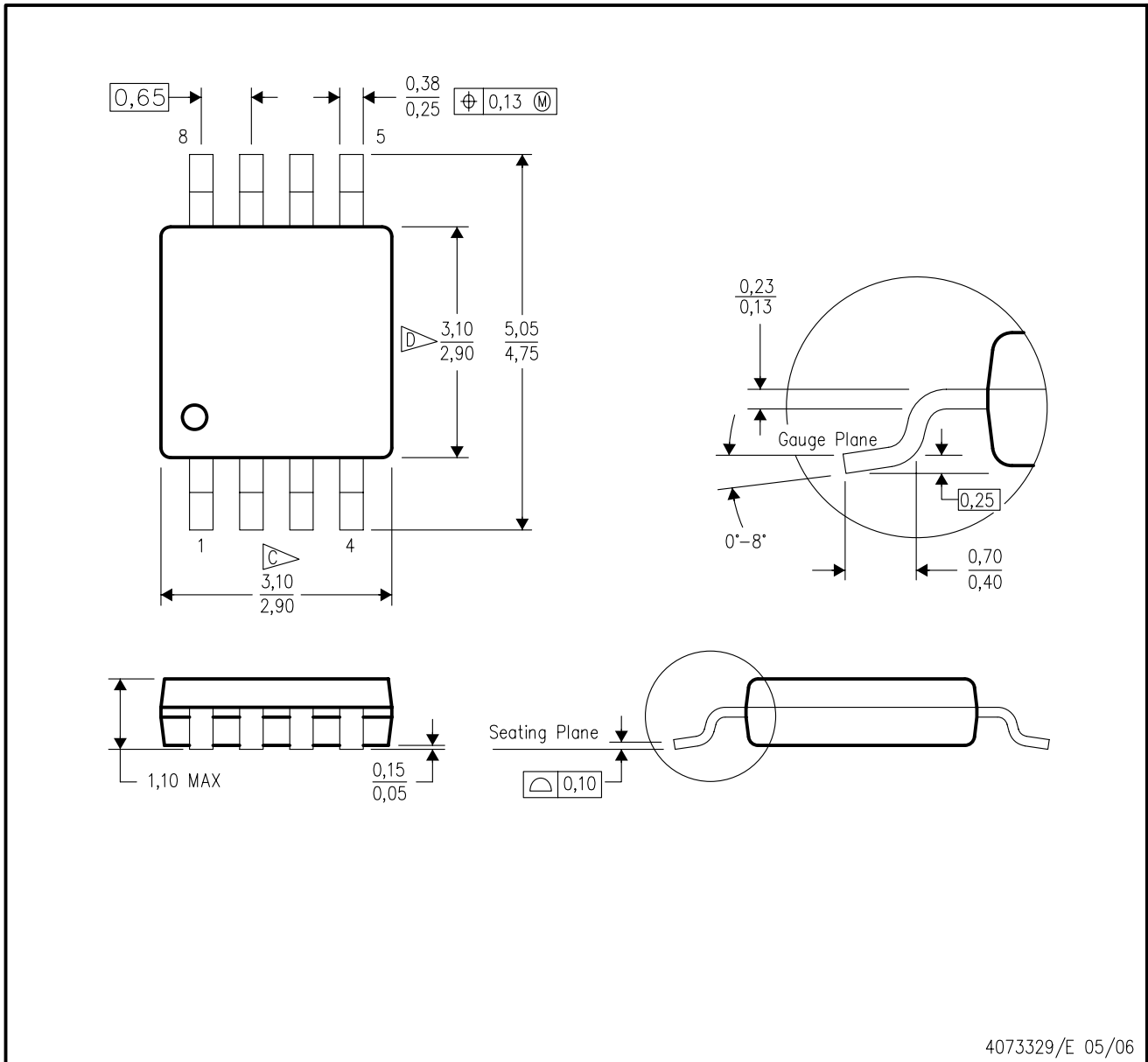

- NOTES:
- A. All linear dimensions are in millimeters.
 - B. This drawing is subject to change without notice.
 - C. Body length does not include mold flash, protrusions, or gate burrs. Mold flash, protrusions, or gate burrs shall not exceed 0.15 per end.
 - D. Body width does not include interlead flash. Interlead flash shall not exceed 0.50 per side.
 - E. Falls within JEDEC MO-187 variation AA, except interlead flash.



- NOTES:
- A. All linear dimensions are in millimeters.
 - B. This drawing is subject to change without notice.
 - C. Publication IPC-7351 is recommended for alternate designs.
 - D. Laser cutting apertures with trapezoidal walls and also rounding corners will offer better paste release. Customers should contact their board assembly site for stencil design recommendations. Refer to IPC-7525 for other stencil recommendations.
 - E. Customers should contact their board fabrication site for solder mask tolerances between and around signal pads.

IMPORTANT NOTICE

Texas Instruments Incorporated (TI) reserves the right to make corrections, enhancements, improvements and other changes to its semiconductor products and services per JESD46, latest issue, and to discontinue any product or service per JESD48, latest issue. Buyers should obtain the latest relevant information before placing orders and should verify that such information is current and complete.

TI's published terms of sale for semiconductor products (<http://www.ti.com/sc/docs/stdterms.htm>) apply to the sale of packaged integrated circuit products that TI has qualified and released to market. Additional terms may apply to the use or sale of other types of TI products and services.

Reproduction of significant portions of TI information in TI data sheets is permissible only if reproduction is without alteration and is accompanied by all associated warranties, conditions, limitations, and notices. TI is not responsible or liable for such reproduced documentation. Information of third parties may be subject to additional restrictions. Resale of TI products or services with statements different from or beyond the parameters stated by TI for that product or service voids all express and any implied warranties for the associated TI product or service and is an unfair and deceptive business practice. TI is not responsible or liable for any such statements.

Buyers and others who are developing systems that incorporate TI products (collectively, "Designers") understand and agree that Designers remain responsible for using their independent analysis, evaluation and judgment in designing their applications and that Designers have full and exclusive responsibility to assure the safety of Designers' applications and compliance of their applications (and of all TI products used in or for Designers' applications) with all applicable regulations, laws and other applicable requirements. Designer represents that, with respect to their applications, Designer has all the necessary expertise to create and implement safeguards that (1) anticipate dangerous consequences of failures, (2) monitor failures and their consequences, and (3) lessen the likelihood of failures that might cause harm and take appropriate actions. Designer agrees that prior to using or distributing any applications that include TI products, Designer will thoroughly test such applications and the functionality of such TI products as used in such applications.

TI's provision of technical, application or other design advice, quality characterization, reliability data or other services or information, including, but not limited to, reference designs and materials relating to evaluation modules, (collectively, "TI Resources") are intended to assist designers who are developing applications that incorporate TI products; by downloading, accessing or using TI Resources in any way, Designer (individually or, if Designer is acting on behalf of a company, Designer's company) agrees to use any particular TI Resource solely for this purpose and subject to the terms of this Notice.

TI's provision of TI Resources does not expand or otherwise alter TI's applicable published warranties or warranty disclaimers for TI products, and no additional obligations or liabilities arise from TI providing such TI Resources. TI reserves the right to make corrections, enhancements, improvements and other changes to its TI Resources. TI has not conducted any testing other than that specifically described in the published documentation for a particular TI Resource.

Designer is authorized to use, copy and modify any individual TI Resource only in connection with the development of applications that include the TI product(s) identified in such TI Resource. NO OTHER LICENSE, EXPRESS OR IMPLIED, BY ESTOPPEL OR OTHERWISE TO ANY OTHER TI INTELLECTUAL PROPERTY RIGHT, AND NO LICENSE TO ANY TECHNOLOGY OR INTELLECTUAL PROPERTY RIGHT OF TI OR ANY THIRD PARTY IS GRANTED HEREIN, including but not limited to any patent right, copyright, mask work right, or other intellectual property right relating to any combination, machine, or process in which TI products or services are used. Information regarding or referencing third-party products or services does not constitute a license to use such products or services, or a warranty or endorsement thereof. Use of TI Resources may require a license from a third party under the patents or other intellectual property of the third party, or a license from TI under the patents or other intellectual property of TI.

TI RESOURCES ARE PROVIDED "AS IS" AND WITH ALL FAULTS. TI DISCLAIMS ALL OTHER WARRANTIES OR REPRESENTATIONS, EXPRESS OR IMPLIED, REGARDING RESOURCES OR USE THEREOF, INCLUDING BUT NOT LIMITED TO ACCURACY OR COMPLETENESS, TITLE, ANY EPIDEMIC FAILURE WARRANTY AND ANY IMPLIED WARRANTIES OF MERCHANTABILITY, FITNESS FOR A PARTICULAR PURPOSE, AND NON-INFRINGEMENT OF ANY THIRD PARTY INTELLECTUAL PROPERTY RIGHTS. TI SHALL NOT BE LIABLE FOR AND SHALL NOT DEFEND OR INDEMNIFY DESIGNER AGAINST ANY CLAIM, INCLUDING BUT NOT LIMITED TO ANY INFRINGEMENT CLAIM THAT RELATES TO OR IS BASED ON ANY COMBINATION OF PRODUCTS EVEN IF DESCRIBED IN TI RESOURCES OR OTHERWISE. IN NO EVENT SHALL TI BE LIABLE FOR ANY ACTUAL, DIRECT, SPECIAL, COLLATERAL, INDIRECT, PUNITIVE, INCIDENTAL, CONSEQUENTIAL OR EXEMPLARY DAMAGES IN CONNECTION WITH OR ARISING OUT OF TI RESOURCES OR USE THEREOF, AND REGARDLESS OF WHETHER TI HAS BEEN ADVISED OF THE POSSIBILITY OF SUCH DAMAGES.

Unless TI has explicitly designated an individual product as meeting the requirements of a particular industry standard (e.g., ISO/TS 16949 and ISO 26262), TI is not responsible for any failure to meet such industry standard requirements.

Where TI specifically promotes products as facilitating functional safety or as compliant with industry functional safety standards, such products are intended to help enable customers to design and create their own applications that meet applicable functional safety standards and requirements. Using products in an application does not by itself establish any safety features in the application. Designers must ensure compliance with safety-related requirements and standards applicable to their applications. Designer may not use any TI products in life-critical medical equipment unless authorized officers of the parties have executed a special contract specifically governing such use. Life-critical medical equipment is medical equipment where failure of such equipment would cause serious bodily injury or death (e.g., life support, pacemakers, defibrillators, heart pumps, neurostimulators, and implantables). Such equipment includes, without limitation, all medical devices identified by the U.S. Food and Drug Administration as Class III devices and equivalent classifications outside the U.S.

TI may expressly designate certain products as completing a particular qualification (e.g., Q100, Military Grade, or Enhanced Product). Designers agree that it has the necessary expertise to select the product with the appropriate qualification designation for their applications and that proper product selection is at Designers' own risk. Designers are solely responsible for compliance with all legal and regulatory requirements in connection with such selection.

Designer will fully indemnify TI and its representatives against any damages, costs, losses, and/or liabilities arising out of Designer's non-compliance with the terms and provisions of this Notice.

Mouser Electronics

Authorized Distributor

Click to View Pricing, Inventory, Delivery & Lifecycle Information:

[Texas Instruments:](#)

[TCA9617ADGKR](#)