

PLLatinum™ Dual High Frequency Synthesizer for RF Personal Communications

LMX2430 3.0 GHz/0.8 GHz, LMX2433 3.6 GHz/1.7 GHz, LMX2434 5.0 GHz/2.5 GHz

Check for Samples: [LMX2430](#), [LMX2433](#), [LMX2434](#)

FEATURES

- **Low Current Consumption**
- **2.25V to 2.75V Operation**
- **Selectable Synchronous or Asynchronous Powerdown Mode**
- **Selectable Dual Modulus Prescaler:**
 - LMX2430 RF: 8/9 or 16/17
 - LMX2433 RF: 8/9 or 16/17
 - LMX2434 RF: 16/17 or 32/33
 - LMX243x IF: 8/9 or 16/17
- **Programmable Charge Pump Current Levels**
 - RF and IF: 1 or 4 mA
- **Fastlock Technology with Integrated Timeout Counters**
- **Digital Filtered Lock Detect Output**
- **Analog Lock Detect Output (supports both Push-Pull and Open Drain configurations)**
- **1.8V MICROWIRE Logic Interface**
- **Available in 20-Pin TSSOP and 20-Pin ULGA**

APPLICATIONS

- **Mobile Handsets**
 - (GSM, GPRS, W-CDMA, CDMA, PCS, AMPS, PDC, DCS)
- **Cordless Handsets**
 - (DECT, DCT)
- **Wireless Data**
- **Cable TV Tuners**

DESCRIPTION

The LMX243x devices are high performance frequency synthesizers with integrated dual modulus prescalers. The LMX243x devices are designed for use as RF and IF local oscillators for dual conversion radio transceivers.

A 32/33 or a 16/17 prescale ratio can be selected for the 5.0 GHz LMX2434 RF synthesizer. An 8/9 or a 16/17 prescale ratio can be selected for both the LMX2430 and LMX2433 RF synthesizers. The IF circuitry contains an 8/9 or a 16/17 prescaler. Using a proprietary digital phase locked loop technique, the LMX243x devices generate very stable, low noise control signals for RF and IF voltage controlled oscillators. Both the RF and IF synthesizers include a two-level programmable charge pump. Both the RF and IF synthesizers have dedicated Fastlock circuitry with integrated timeout counters. Furthermore, only a single word write is required to power up and tune the synthesizers to a new frequency.

Serial data is transferred to the devices via a three-wire interface (DATA, LE, CLK). A low voltage logic interface allows direct connection to 1.8V devices. Supply voltages from 2.25V to 2.75V are supported. The LMX243x family features low current consumption:

LMX2430 (3.0 GHz/ 0.8 GHz)—2.8 mA/ 1.4 mA,
 LMX2433 (3.6 GHz/ 1.7 GHz) —3.2 mA/ 2.0 mA,
 LMX2434 (5.0 GHz/ 2.5 GHz)—4.6 mA/ 2.4 mA at 2.50V.

The LMX243x devices are available in 20-Pin TSSOP and 20-Pin ULGA surface mount plastic packages.

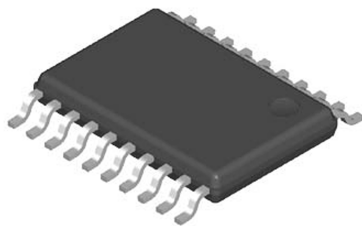

Figure 1. Thin Shrink Small Outline Package (PW0020A)

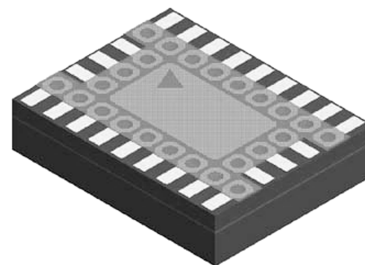

Figure 2. Ultra Thin Chip Scale Package (NPE0020A)



Please be aware that an important notice concerning availability, standard warranty, and use in critical applications of Texas Instruments semiconductor products and disclaimers thereto appears at the end of this data sheet.

PLLatinum is a trademark of Texas Instruments.

All other trademarks are the property of their respective owners.

Functional Block Diagram

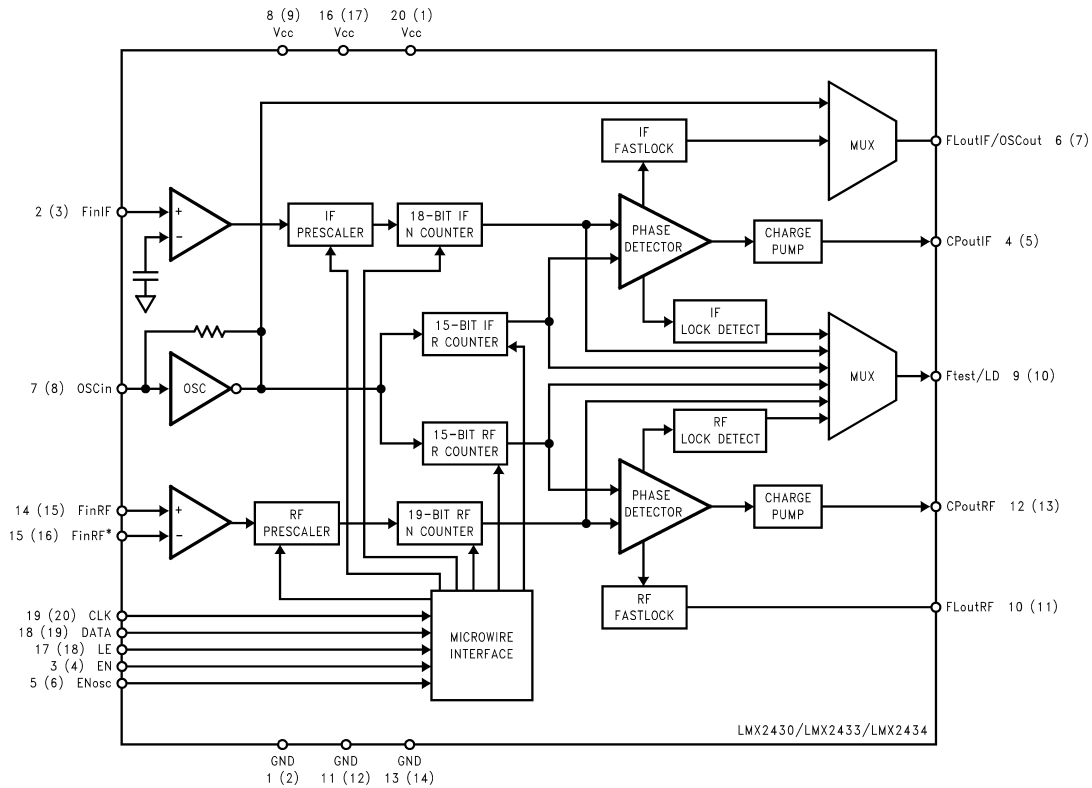

Note:1 (2) refers to Pin #1 of the 20-Pin ULGA and Pin #2 of the 20-Pin TSSOP

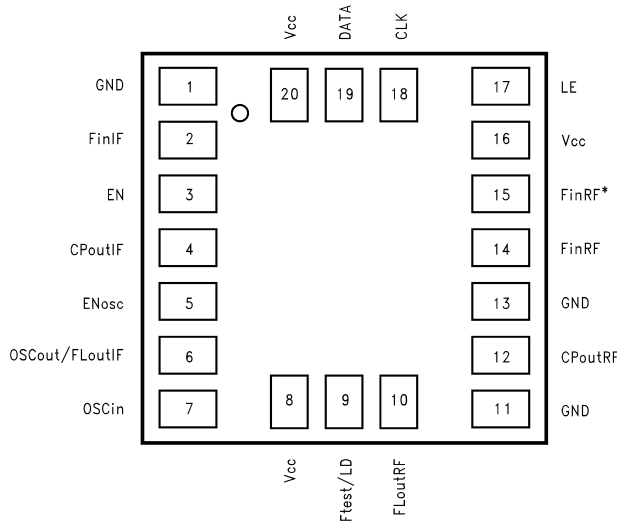
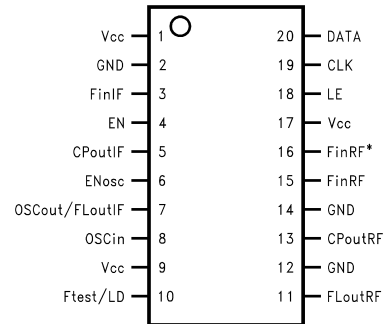
Connection Diagrams

Figure 3. Ultra Thin Chip Scale Package (NPE) (Top View)

Figure 4. Thin Shrink Small Outline Package (PW) (Top View)
Pin Descriptions

Pin No. ULGA	Pin No. TSSOP	Pin Name	I/O	Description
1	2	GND	—	Ground for the IF PLL analog and digital circuits, MICROWIRE™, Ftest/LD and oscillator circuits.
2	3	FinIF	I	IF PLL prescaler input. Small signal input from the VCO.
3	4	EN	I	Chip Enable input. High Impedance CMOS input. When this pin is set HIGH, the RF and IF PLLs are powered up. Powerdown is then controlled through the MICROWIRE. When this pin is set LOW, the device is asynchronously powered down and the charge pump output is forced to a high impedance state (TRI-STATE).
4	5	CPoutIF	O	IF PLL charge pump output. The output is connected to the external loop filter, which drives the input of the IF VCO.
5	6	ENosc	I	Oscillator Enable input. High impedance CMOS input. When this pin is set HIGH, the oscillator buffer is always powered up, independent of the state of the EN pin. When this pin is set LOW, the OSCout/ FLoutIF pin functions as an IF Fastlock output, which connects a resistor in parallel to R2 of the external loop filter.
6	7	OSCout/ FLoutIF	O	Oscillator output/ IF PLL Fastlock output. The output configuration is dependent on the state of the ENosc pin. When ENosc is set LOW, the pin functions as an IF Fastlock output, which connects a resistor in parallel to R2 of the external loop filter. This configuration also functions as a general purpose CMOS TRI-STATE output. When ENosc is set HIGH, the pin functions as an oscillator output so that an external crystal can be used.
7	8	OSCin	I	Reference oscillator input. The input has an approximate Vcc/2 threshold and is driven by an external AC coupled source.
8	9	Vcc	—	Power supply bias for the RF PLL digital circuits and oscillator circuits. Vcc may range from 2.25V to 2.75V. Bypass capacitors should be placed as close as possible to this pin and be connected directly to the ground plane.
9	10	Ftest/LD	O	Programmable multiplexed output. Functions as a general purpose CMOS TRI-STATE output, N and R divider output, RF/ IF PLL push-pull analog lock detect output, RF/ IF PLL open-drain analog lock detect output, or RF/ IF PLL digital filtered lock detect output.
10	11	FLoutRF	O	RF PLL Fastlock output. This pin connects a resistor in parallel to R2 of the external loop filter. This pin can also function as a general purpose CMOS TRI-STATE output.
11	12	GND	—	Ground for the RF PLL digital circuits.

Pin Descriptions (continued)

Pin No. ULGA	Pin No. TSSOP	Pin Name	I/O	Description
12	13	CPoutRF	O	RF PLL charge pump output. The output is connected to the external loop filter, which drives the input of the RF VCO.
13	14	GND	—	Ground for the RF PLL analog circuits.
14	15	FinRF	I	RF PLL prescaler input. Small signal input from the VCO.
15	16	FinRF*	I	RF PLL prescaler complementary input. For single ended operation, this pin should be AC grounded through a 100 pF capacitor. The LMX243x can be driven differentially when the AC coupled capacitor is omitted.
16	17	Vcc	—	Power supply bias for the RF PLL analog circuits. Vcc may range from 2.25V to 2.75V. Bypass capacitors should be placed as close as possible to this pin and be connected directly to the ground plane.
17	18	LE	I	MICROWIRE Latch Enable input. High impedance CMOS input. When LE transitions HIGH, DATA stored in the shift register is loaded into one of 6 internal control registers.
18	19	CLK	I	MICROWIRE Clock input. High impedance CMOS input. DATA is clocked into the 24-bit shift register on the rising edge of CLK.
19	20	DATA	I	MICROWIRE Data input. High impedance CMOS input. Binary serial data. The MSB of DATA is shifted in first. The two last bits are the control bits.
20	1	Vcc	—	Power supply bias for the IF PLL analog and digital circuits, MICROWIRE, and Ftest/LD circuits. Vcc may range from 2.25V to 2.75V. Bypass capacitors should be placed as close as possible to this pin and be connected directly to the ground plane.



These devices have limited built-in ESD protection. The leads should be shorted together or the device placed in conductive foam during storage or handling to prevent electrostatic damage to the MOS gates.

Absolute Maximum Ratings⁽¹⁾⁽²⁾⁽³⁾⁽⁴⁾

Power Supply Voltage Vcc to GND	-0.3V to +3.25V
Voltage on any pin to GND (V _I) V _I must be < +3.25V	-0.3V to Vcc+0.3V
Storage Temperature Range (T _S)	-65°C to +150°C
Lead Temperature (solder 4 s) (T _L)	+260°C

- (1) This device is a high performance RF integrated circuit with an ESD rating <2 kV and is ESD sensitive. Handling and assembly of this device should only be done at ESD protected work stations.
- (2) GND = 0V
- (3) Absolute Maximum Ratings indicate limits beyond which damage to the device may occur. Recommended Operating Conditions indicate conditions for which the device is intended to be functional, but do not ensure specific performance limits. For ensured specifications and test conditions, refer to the Electrical Characteristics section. The ensured specifications apply only for the conditions listed.
- (4) If Military/Aerospace specified devices are required, please contact the Texas Instruments Sales Office/ Distributors for availability and specifications.

Recommended Operating Conditions⁽¹⁾

Power Supply Voltage Vcc to GND	+2.25V to +2.75V
Operating Temperature (T _A)	-40°C to +85°C

- (1) Absolute Maximum Ratings indicate limits beyond which damage to the device may occur. Recommended Operating Conditions indicate conditions for which the device is intended to be functional, but do not ensure specific performance limits. For ensured specifications and test conditions, refer to the Electrical Characteristics section. The ensured specifications apply only for the conditions listed.

Electrical Characteristics

V_{CC} = EN = 2.5V, -40°C ≤ T_A ≤ +85°C, unless otherwise specified

Symbol	Parameter	Conditions	Value			Units	
			Min	Typ	Max		
I_{CC} PARAMETERS							
I _{CCRF}	Power Supply Current, RF Synthesizer	LMX2430	CLK, DATA and LE = 0V		2.8	3.6	mA
		LMX2433	OSCin = GND RF_PD Bit = 0		3.2	4.4	mA
		LMX2434	IF_PD Bit = 1 RF_P Bit = 0		4.6	6.2	mA
I _{CCIF}	Power Supply Current, IF Synthesizer	LMX2430	CLK, DATA and LE = 0V		1.4	2.0	mA
		LMX2433	OSCin = GND RF_PD Bit = 1		2.0	2.8	mA
		LMX2434	IF_PD Bit = 0 IF_P Bit = 0		2.4	3.5	mA
I _{CCPD}	Powerdown Current	EN, ENosc, CLK, DATA and LE = 0V				10	μA
RF SYNTHESIZER PARAMETERS							
f _{FinRF}	RF Operating Frequency	LMX2430	RF_P Bit = 0	250		2500	MHz
			RF_P Bit = 1	250		3000	MHz
		LMX2433	RF_P Bit = 0	500		3000	MHz
			RF_P Bit = 1	500		3600	MHz
		LMX2434	RF_P Bit = 0 or 1	1000		5000	MHz
N _{RF}	N Divider Range	P = 8/9 ⁽¹⁾		24		262151	
		P = 16/17 ⁽¹⁾		48		524287	
		P = 32/33 ⁽¹⁾		96		524287	
R _{RF}	RF R Divider Range			3		32767	
f _{COMPRF}	RF Phase Detector Frequency					10	MHz
P _{FinRF}	RF Input Sensitivity	LMX2430/33 2.25V ≤ V _{CC} ≤ 2.75V ⁽²⁾		-15		0	dBm
		LMX2434 2.35V ≤ V _{CC} ≤ 2.75V ⁽²⁾		-12		0	dBm
I _{CPoutRF Source}	RF Charge Pump Output Source Current	V _{CPoutRF} = V _{CC} /2 RF_CPG Bit = 0 ⁽³⁾			-1.0		mA
		V _{CPoutRF} = V _{CC} /2 RF_CPG Bit = 1 ⁽³⁾			-4.0		mA
I _{CPoutRF Sink}	RF Charge Pump Output Sink Current	V _{CPoutRF} = V _{CC} /2 RF_CPG Bit = 0 ⁽³⁾			1.0		mA
		V _{CPoutRF} = V _{CC} /2 RF_CPG Bit = 1 ⁽³⁾			4.0		mA
I _{CPoutRF TRI}	RF Charge Pump Output TRI-STATE Current	0.5V ≤ V _{CPoutRF} ≤ V _{CC} - 0.5V ⁽³⁾		-2.5		2.5	nA
I _{CPoutRF %MIS}	RF Charge Pump Output Sink Current Vs Charge Pump Output Source Current Mismatch	V _{CPoutRF} = V _{CC} /2 ⁽⁴⁾			3	10	%
I _{CPoutRF %V_{CPoutRF}}	RF Charge Pump Output Current Magnitude Variation Vs Charge Pump Output Voltage	0.5V ≤ V _{CPoutRF} ≤ V _{CC} - 0.5V ⁽⁴⁾			5	15	%
I _{CPoutRF %T_A}	RF Charge Pump Output Current Magnitude Variation Vs Temperature	V _{CPoutRF} = V _{CC} /2 ⁽⁴⁾			2		%

(1) Some of the values in this range are illegal divide ratios (B < A). To obtain continuous legal division, the Minimum Divide Ratio must be calculated. Use N ≥ P * (P-1), where P is the value of the prescaler selected.

(2) Refer to the [LMX243x FinRF Sensitivity Test Setup](#) section

(3) Refer to the [LMX243x Charge Pump Test Setup](#) section

(4) Refer to the [Charge Pump Current Specification Definitions](#) for details on how these measurements are made.

Electrical Characteristics (continued)

V_{CC} = EN = 2.5V, -40°C ≤ T_A ≤ +85°C, unless otherwise specified

Symbol	Parameter	Conditions	Value			Units	
			Min	Typ	Max		
IF SYNTHESIZER PARAMETERS							
f _{FinIF}	IF Operating Frequency	LMX2430	IF_P Bit = 0 or 1	100		800	MHz
		LMX2433	IF_P Bit = 0 or 1	250		1700	MHz
		LMX2434	IF_P Bit = 0 or 1	500		2500	MHz
N _{IF}	IF N Divider Range		P = 8/9 ⁽⁵⁾	24		131079	
			P = 16/17 ⁽⁵⁾	48		262143	
R _{IF}	IF R Divider Range			3		32767	
f _{COMPIF}	IF Phase Detector Frequency					10	MHz
P _{FinIF}	IF Input Sensitivity	2.25V ≤ V _{CC} ≤ 2.75V ⁽⁶⁾		-15		0	dBm
I _{CPoutIF Source}	IF Charge Pump Output Source Current	V _{CPoutIF} = V _{CC} /2 IF_CPG Bit = 0 ⁽⁷⁾			-1.0		mA
		V _{CPoutIF} = V _{CC} /2 IF_CPG Bit = 1 ⁽⁷⁾			-4.0		mA
I _{CPoutIF Sink}	IF Charge Pump Output Sink Current	V _{CPoutIF} = V _{CC} /2 IF_CPG Bit = 0 ⁽⁷⁾			1.0		mA
		V _{CPoutIF} = V _{CC} /2 IF_CPG Bit = 1 ⁽⁷⁾			4.0		mA
I _{CPoutIF TRI}	IF Charge Pump Output TRI-STATE Current	0.5V ≤ V _{CPoutIF} ≤ V _{CC} - 0.5V ⁽⁷⁾		-2.5		2.5	nA
I _{CPoutIF %MIS}	IF Charge Pump Output Sink Current Vs Charge Pump Output Source Current Mismatch	V _{CPoutIF} = V _{CC} /2 ⁽⁸⁾			3	10	%
I _{CPoutIF %V_{CPoutIF}}	IF Charge Pump Output Current Magnitude Variation Vs Charge Pump Output Voltage	0.5V ≤ V _{CPoutIF} ≤ V _{CC} - 0.5V ⁽⁸⁾			5	15	%
I _{CPoutIF %T_A}	IF Charge Pump Output Current Magnitude Variation Vs Temperature	V _{CPoutIF} = V _{CC} /2 ⁽⁸⁾			2		%
OSCILLATOR PARAMETERS							
f _{OSCin}	Oscillator Operating Frequency			1		256	MHz
V _{OSCin}	Oscillator Sensitivity	See ⁽⁹⁾		0.5		V _{CC}	V _{PP}
I _{OSCin}	Oscillator Input Current	V _{OSCin} = V _{CC}				100	μA
		V _{OSCin} = 0V		-100			μA
DIGITAL INTERFACE (DATA, CLK, LE, EN, ENosc, Ftest/LD, FLOutRF, OSCout/ FLOutIF)							
V _{IH}	High-Level Input Voltage			1.6			V
V _{IL}	Low-Level Input Voltage					0.4	V
I _{IH}	High-Level Input Current	V _{IH} = V _{CC}				1.0	μA
I _{IL}	Low-Level Input Current	V _{IL} = 0V		-1.0			μA
V _{OH}	High-Level Output Voltage	I _{OH} = -500 μA		V _{CC} - 0.4			V
V _{OL}	Low-Level Output Voltage	I _{OL} = 500 μA				0.4	V
MICROWIRE INTERFACE							
t _{CS}	DATA to CLK Set Up Time	See ⁽¹⁰⁾		50			ns
t _{CH}	DATA to CLK Hold Time	See ⁽¹⁰⁾		10			ns
t _{CWH}	CLK Pulse Width HIGH	See ⁽¹⁰⁾		50			ns

(5) Some of the values in this range are illegal divide ratios (B < A). To obtain continuous legal division, the Minimum Divide Ratio must be calculated. Use N ≥ P * (P-1), where P is the value of the prescaler selected.
 (6) Refer to the [LMX243x FinRF Sensitivity Test Setup](#) section
 (7) Refer to the [LMX243x Charge Pump Test Setup](#) section
 (8) Refer to the [Charge Pump Current Specification Definitions](#) for details on how these measurements are made.
 (9) Refer to the [LMX243x OSCin Sensitivity Test Setup](#) section
 (10) Refer to the [LMX243x Serial Data Input Timing](#) figure

Electrical Characteristics (continued)
 $V_{CC} = EN = 2.5V$, $-40^{\circ}C \leq T_A \leq +85^{\circ}C$, unless otherwise specified

Symbol	Parameter	Conditions	Value			Units	
			Min	Typ	Max		
t_{CWL}	CLK Pulse Width LOW	See ⁽¹⁰⁾	50			ns	
t_{ES}	CLK to LE Set Up Time	See ⁽¹⁰⁾	50			ns	
t_{EW}	LE Pulse Width	See ⁽¹⁰⁾	50			ns	
PHASE NOISE CHARACTERISTICS							
$L_{NRF}(f)$	RF Synthesizer Normalized Phase Noise Contribution ⁽¹¹⁾	TCXO Reference Source RF_CPG Bit = 1 IF_PD Bit = 1		-219.0		dBc/ Hz	
$L_{NIF}(f)$	IF Synthesizer Normalized Phase Noise Contribution ⁽¹¹⁾	TCXO Reference Source IF_CPG Bit = 1 RF_PD Bit = 1		-214.0		dBc/ Hz	
$L_{RF}(f)$	RF Synthesizer Single Side Band Phase Noise Measured	LMX2430	$f_{FinRF} = 2750$ MHz $f = 10$ kHz offset $f_{COMP} = 1$ MHz Loop Bandwidth = 100 kHz $N_{RF} = 2750$ $f_{OSCin} = 10$ MHz $V_{OSCin} = 1 V_{PP}$ RF_CPG Bit = 1 IF_PD Bit = 1 $T_A = +25^{\circ}C$ ⁽¹²⁾		-90.30		dBc/ Hz
		LMX2433	$f_{FinRF} = 3200$ MHz $f = 10$ kHz offset $f_{COMP} = 1$ MHz Loop Bandwidth = 100 kHz $N_{RF} = 3200$ $f_{OSCin} = 10$ MHz $V_{OSCin} = 1 V_{PP}$ RF_CPG Bit = 1 IF_PD Bit = 1 $T_A = +25^{\circ}C$ ⁽¹²⁾		-88.90		dBc/ Hz
		LMX2434	$f_{FinRF} = 4700$ MHz $f = 10$ kHz offset $f_{COMP} = 1$ MHz Loop Bandwidth = 100 kHz $N_{RF} = 4700$ $f_{OSCin} = 10$ MHz $V_{OSCin} = 1 V_{PP}$ RF_CPG Bit = 1 IF_PD Bit = 1 $T_A = +25^{\circ}C$ ⁽¹²⁾		-85.60		dBc/ Hz

(11) Normalized Phase Noise Contribution is defined as : $L_N(f) = L(f) - 20 \log(N) - 10 \log(f_{COMP})$, where $L(f)$ is defined as the single side band phase noise measured at an offset frequency, f , in a 1 Hz bandwidth. The offset frequency, f , must be chosen sufficiently smaller than the PLL's loop bandwidth, yet large enough to avoid substantial phase noise contribution from the reference source. N is the value selected for the feedback divider and f_{COMP} is the RF/IF phase/ frequency detector comparison frequency.

(12) The synthesizer phase noise is measured with the LMX2430PW/LMX2430NPE Evaluation boards and the HP8566B Spectrum Analyzer.

Charge Pump Current Specification Definitions

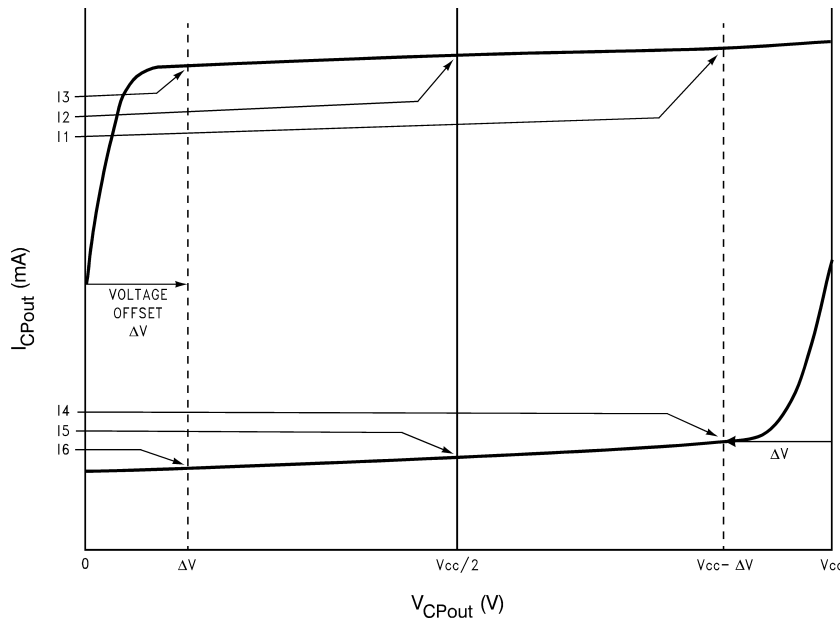

I1 = Charge Pump Sink Current at $V_{CPout} = V_{CC} - \Delta V$
 I2 = Charge Pump Sink Current at $V_{CPout} = V_{CC}/2$
 I3 = Charge Pump Sink Current at $V_{CPout} = \Delta V$
 I4 = Charge Pump Source Current at $V_{CPout} = V_{CC} - \Delta V$
 I5 = Charge Pump Source Current at $V_{CPout} = V_{CC}/2$
 I6 = Charge Pump Source Current at $V_{CPout} = \Delta V$
 ΔV = Voltage offset from the positive and negative rails. Dependent on the VCO tuning range relative to V_{CC} and GND. Typical values are between 0.5V and 1.0V.
 V_{CPout} refers to either $V_{CPoutRF}$ or $V_{CPoutIF}$
 I_{CPout} refers to either $I_{CPoutRF}$ or $I_{CPoutIF}$

Figure 5.

$$I_{CPout} \text{ Vs } V_{CPout} = \frac{(|I1| - |I3|)}{(|I1| + |I3|)} \times 100\%$$

$$= \frac{(|I4| - |I6|)}{(|I4| + |I6|)} \times 100\%$$

Figure 6. Charge Pump Output Current Magnitude Variation Vs Charge Pump Output Voltage

$$I_{CPout} \text{ Sink Vs } I_{CPout} \text{ Source} = \frac{|I2| - |I5|}{\frac{1}{2}(|I2| + |I5|)} \times 100\%$$

Figure 7. Charge Pump Output Sink Current Vs Charge Pump Output Source Current Mismatch

$$\begin{aligned}
 I_{CPout} \text{ Vs } T_A &= \frac{|I_2|_{T_A} - |I_2|_{T_A=25^\circ\text{C}}}{|I_2|_{T_A=25^\circ\text{C}}} \times 100\% \\
 &= \frac{|I_5|_{T_A} - |I_5|_{T_A=25^\circ\text{C}}}{|I_5|_{T_A=25^\circ\text{C}}} \times 100\%
 \end{aligned}$$

Figure 8. Charge Pump Output Current Magnitude Variation Vs Temperature

Typical Performance Characteristics Sensitivity

LMX2430 FinRF Input Power Vs Frequency, Vcc = EN = 2.25V

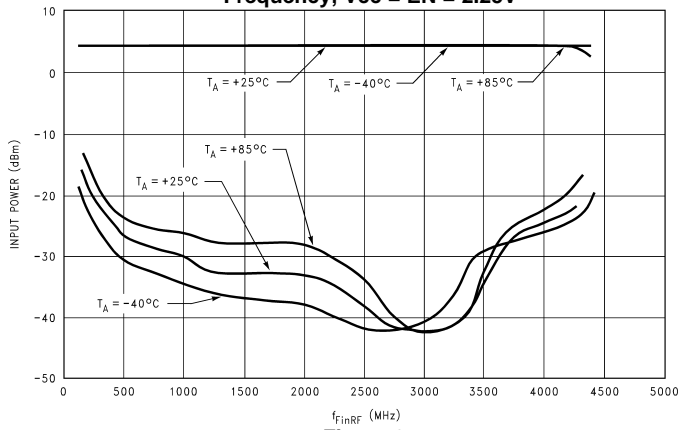

Figure 9.

LMX2430 FinRF Input Power Vs Frequency, Vcc = EN = 2.75V

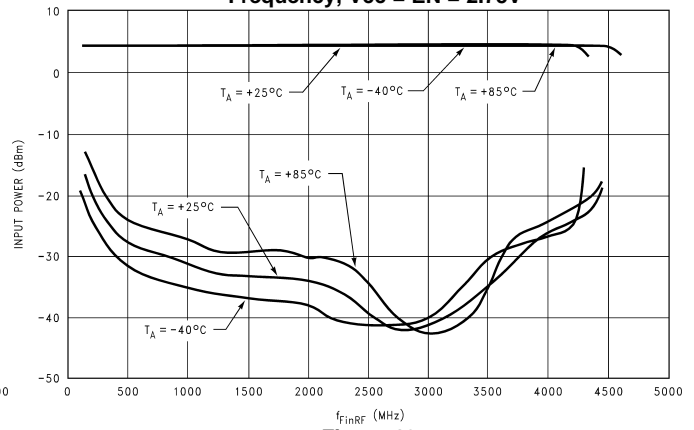

Figure 10.

LMX2433 FinRF Input Power Vs Frequency, Vcc = EN = 2.25V

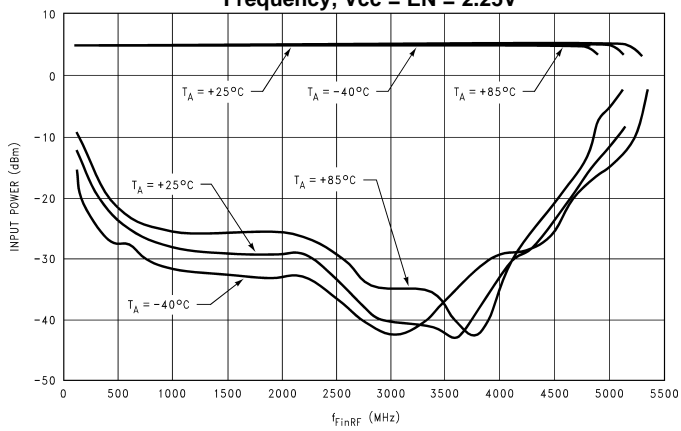

Figure 11.

LMX2433 FinRF Input Power Vs Frequency, Vcc = EN = 2.75V

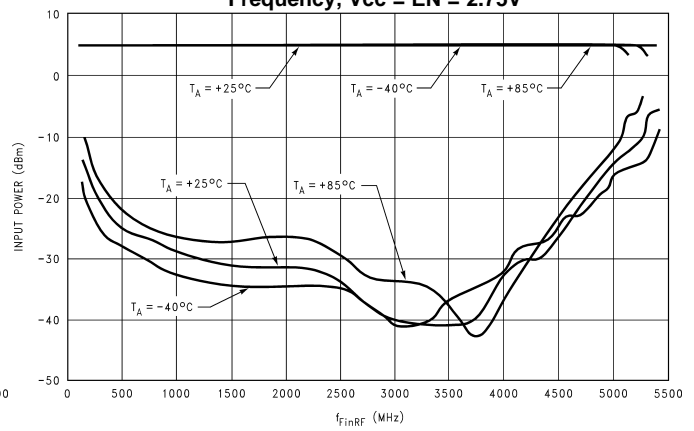

Figure 12.

LMX2434 FinRF Input Power Vs Frequency, Vcc = EN = 2.35V

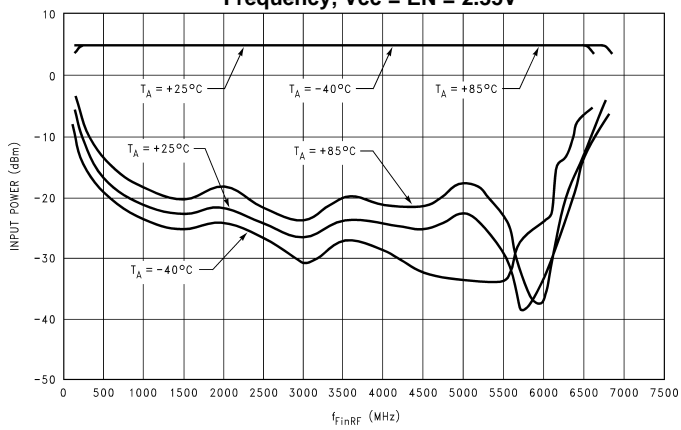

Figure 13.

LMX2434 FinRF Input Power Vs Frequency, Vcc = EN = 2.75V

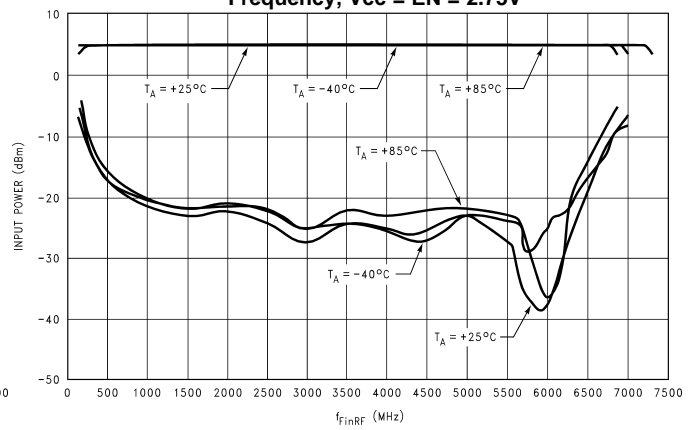

Figure 14.

Typical Performance Characteristics Sensitivity (continued)

LMX2430 FinIF Input Power Vs Frequency, Vcc = EN = 2.25V

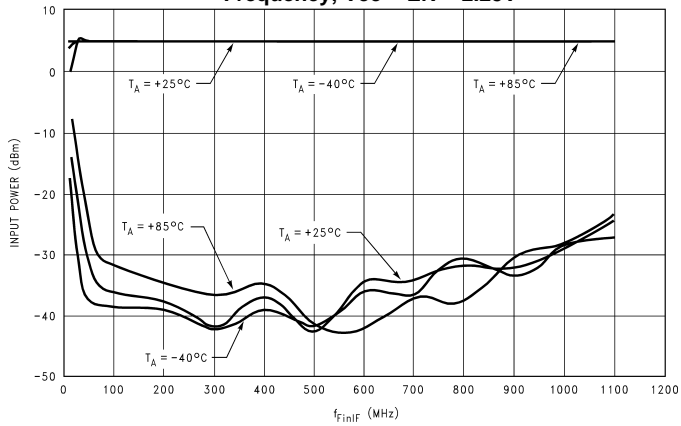

Figure 15.

LMX2430 FinIF Input Power Vs Frequency, Vcc = EN = 2.75V

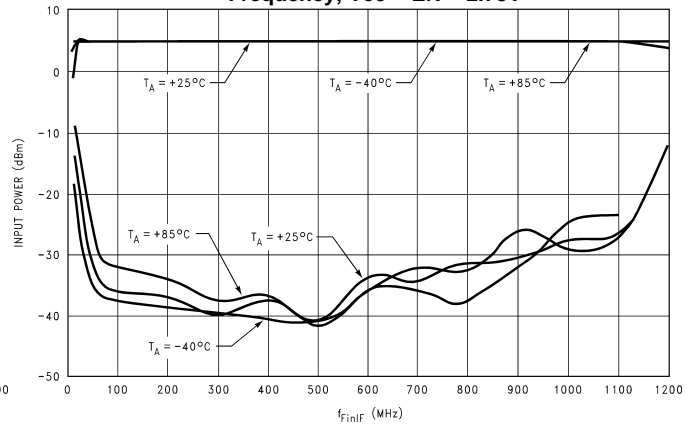

Figure 16.

LMX2433 FinIF Input Power Vs Frequency, Vcc = EN = 2.25V

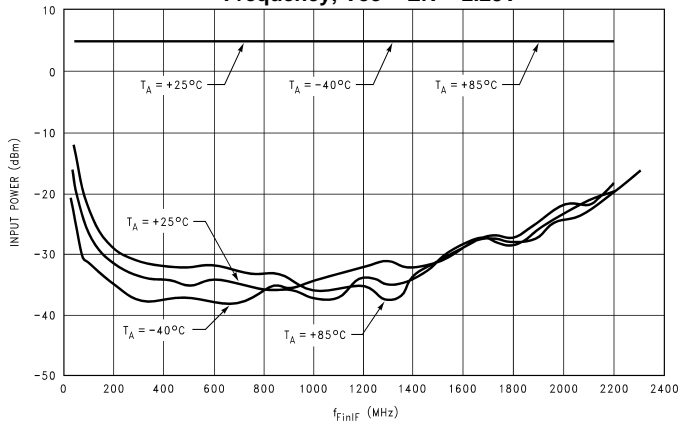

Figure 17.

LMX2433 FinIF Input Power Vs Frequency, Vcc = EN = 2.75V

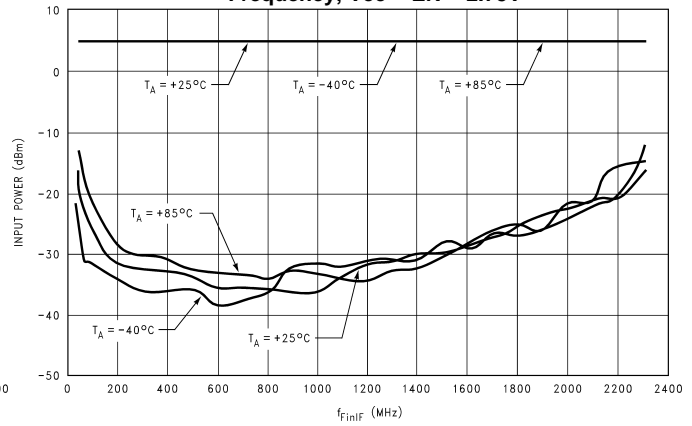

Figure 18.

LMX2434 FinIF Input Power Vs Frequency, Vcc = EN = 2.25V

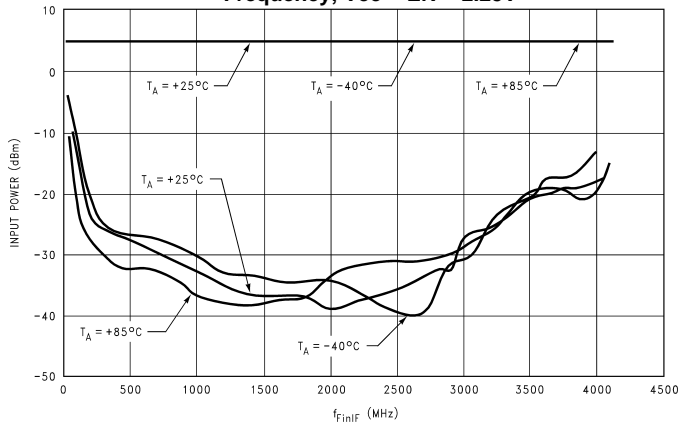

Figure 19.

LMX2434 FinIF Input Power Vs Frequency, Vcc = EN = 2.75V

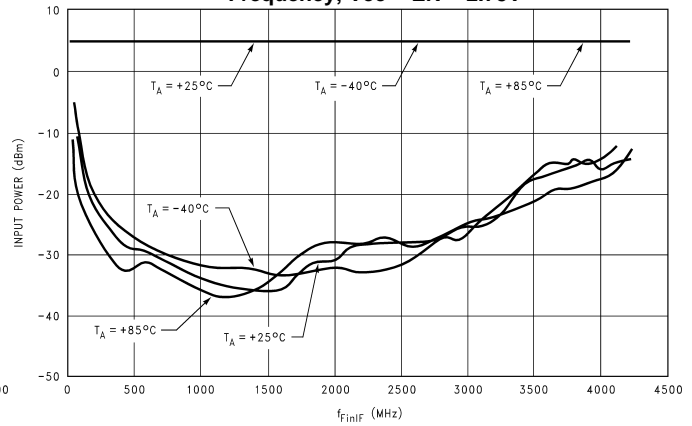

Figure 20.

Typical Performance Characteristics Sensitivity (continued)
LMX243x OSCin Input Voltage
Vs
Frequency, Vcc = EN = 2.25V

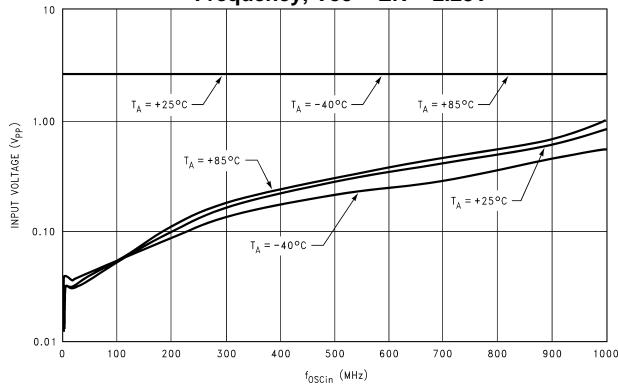

Figure 21.

LMX243x OSCin Input Voltage
Vs
Frequency, Vcc = EN = 2.75V

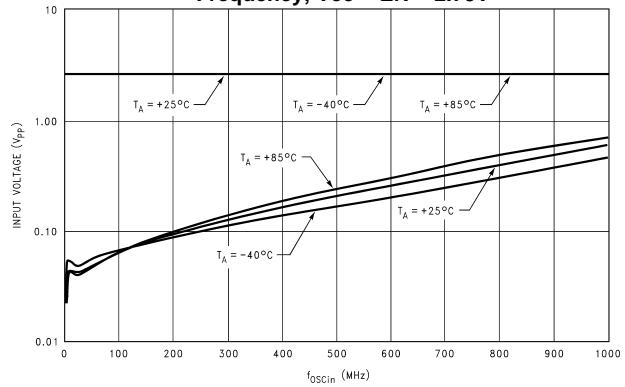

Figure 22.

Typical Performance Characteristics Charge Pump

LMX243x RF Charge Pump Sweeps
Vcc = EN = 2.50V
-40°C ≤ TA ≤ +85°C

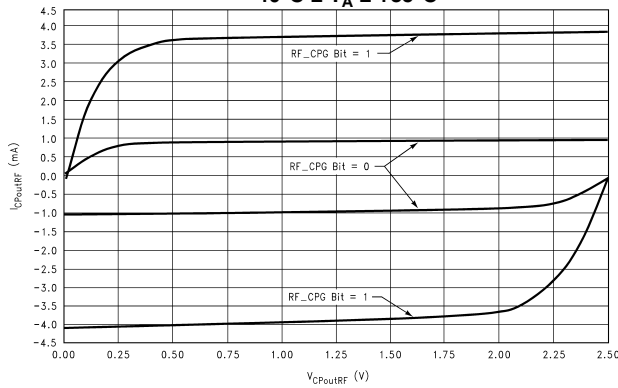

Figure 23.

LMX243x IF Charge Pump Sweeps
Vcc = EN = 2.50V
-40°C ≤ TA ≤ +85°C

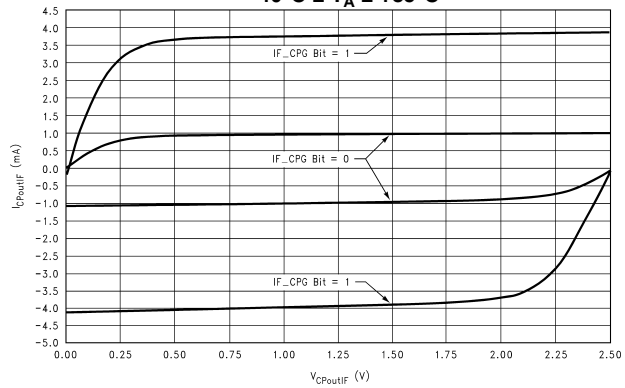
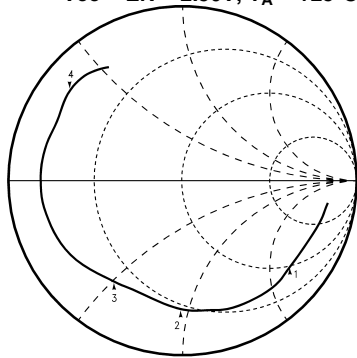

Figure 24.

Typical Performance Characteristics Input Impedance

LMX243x ULGA FinRF Input Impedance
Vcc = EN = 2.50V, TA = +25°C



Marker 1 = 900 MHz
 Marker 2 = 1900 MHz
 Marker 3 = 2500 MHz
 Marker 4 = 5000 MHz
 Figure 25.

LMX243x TSSOP FinRF Input Impedance
Vcc = EN = 2.50V, TA = +25°C

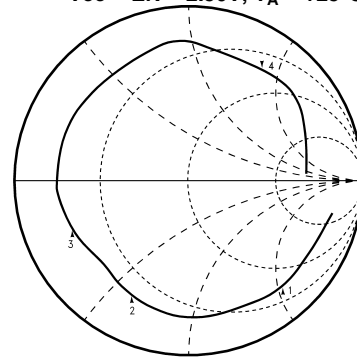

Marker 1 = 900 MHz
 Marker 2 = 1900 MHz
 Marker 3 = 2500 MHz
 Marker 4 = 5000 MHz
 Figure 26.

Typical Performance Characteristics Input Impedance (continued)

LMX243x ULGA FinIF Input Impedance
Vcc = EN = 2.50V, TA = +25°C

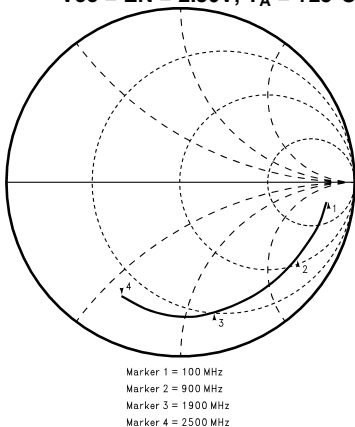

Figure 27.

LMX243x TSSOP FinIF Input Impedance
Vcc = EN = 2.50V, TA = +25°C

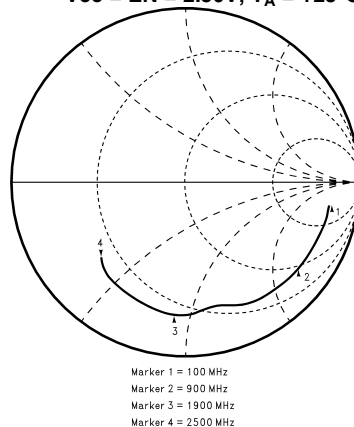

Figure 28.

LMX243x ULGA OSCin Input Impedance Vs Frequency
Vcc = EN = 2.50V
TA = +25°C

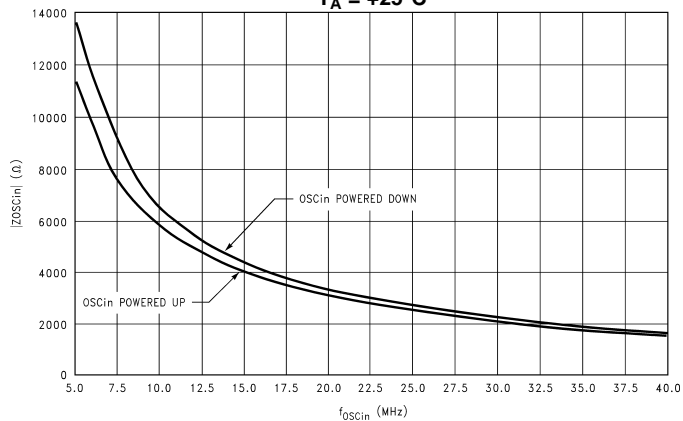

Figure 29.

LMX233xU TSSOP OSCin Input Impedance Vs Frequency
Vcc = EN = 2.50V
TA = +25°C

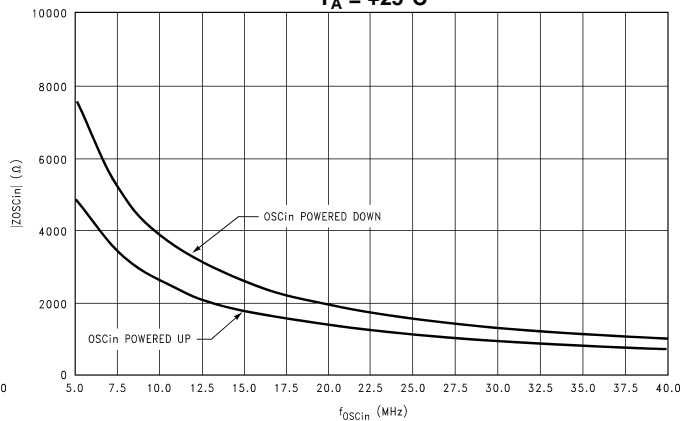

Figure 30.

LMX243x ULGA FinRF Input Impedance Table⁽¹⁾

f_{FinRF} (MHz)	$ \Gamma $	Angle (Γ) (°)	Re {ZFinRF} (Ω)	Im {ZFinRF} (Ω)	ZFinRF (Ω)
100	0.86	-8.63	334.27	-339.55	476.48
200	0.86	-10.72	265.44	-313.48	410.77
300	0.85	-13.48	202.09	-281.42	346.46
400	0.84	-17.01	150.76	-245.31	287.93
500	0.83	-21.05	112.18	-212.85	240.60
600	0.82	-25.32	85.96	-185.41	204.37
700	0.82	-29.78	67.32	-162.49	175.88
800	0.81	-34.35	54.27	-143.15	153.09
900	0.80	-39.02	44.76	-127.07	134.72
1000	0.80	-43.83	37.32	-113.62	119.59
1100	0.79	-48.76	31.65	-102.07	106.86
1200	0.79	-53.90	27.30	-91.89	95.86
1300	0.78	-59.07	23.84	-82.83	86.19
1400	0.78	-64.41	21.34	-74.84	77.82
1500	0.77	-70.04	19.20	-67.56	70.24
1600	0.76	-75.84	17.46	-60.88	63.33
1700	0.75	-82.06	16.27	-54.72	57.09
1800	0.73	-88.56	15.36	-48.89	51.25
1900	0.72	-95.19	14.90	-43.34	45.83
2000	0.70	-101.45	14.32	-38.66	41.23
2100	0.68	-107.85	14.10	-34.26	37.05
2200	0.67	-114.12	13.81	-30.35	33.34
2300	0.66	-120.12	13.27	-27.09	30.17
2400	0.66	-126.01	12.50	-24.00	27.06
2500	0.67	-131.82	11.68	-21.22	24.22
2600	0.69	-137.96	10.55	-18.24	21.07
2700	0.71	-144.21	9.53	-15.58	18.26
2800	0.72	-150.25	8.55	-12.92	15.49
2900	0.74	-156.23	7.75	-10.25	12.85
3000	0.75	-161.92	7.22	-7.77	10.61
3100	0.76	-167.18	6.87	-5.48	8.79
3200	0.77	-172.05	6.63	-3.42	7.46
3300	0.77	-177.55	6.40	-1.49	6.57
3400	0.78	179.16	6.18	0.35	6.19
3500	0.79	174.92	5.99	2.18	6.37
3600	0.79	170.77	5.85	3.99	7.08
3700	0.80	166.54	5.74	5.80	8.16
3800	0.80	162.52	5.73	7.56	9.49
3900	0.80	158.74	5.73	9.22	10.86
4000	0.80	155.06	5.68	10.84	12.24
4100	0.80	151.49	5.69	12.38	13.62
4200	0.80	148.28	5.70	13.78	14.91
4300	0.80	146.02	5.73	14.88	15.95
4400	0.80	144.12	5.60	15.84	16.80
4500	0.82	142.31	5.41	16.66	17.52

(1) $V_{CC} = EN = 2.50V$, $T_A = +25^\circ C$

f_{FinRF} (MHz)	$ \Gamma $	Angle (Γ) ($^{\circ}$)	Re {ZFinRF} (Ω)	Im {ZFinRF} (Ω)	ZFinRF (Ω)
4600	0.83	140.78	5.29	17.42	18.21
4700	0.83	139.65	5.14	17.95	18.67
4800	0.84	138.75	4.99	18.38	19.05
4900	0.84	137.79	4.84	18.85	19.46
5000	0.84	136.82	4.92	19.79	20.39
5100	0.84	135.77	4.88	18.89	19.51
5200	0.84	134.64	4.99	20.44	21.04
5300	0.84	133.33	5.11	21.16	21.77
5400	0.84	131.68	5.25	21.96	22.58
5500	0.83	129.77	5.43	23.01	23.64
5600	0.83	127.55	5.70	24.16	24.82
5700	0.82	125.41	6.03	25.33	26.04
5800	0.82	123.35	6.42	26.41	27.18
5900	0.81	121.68	6.75	27.30	28.12
6000	0.80	120.42	7.11	28.00	28.89

Table 1. LMX243x TSSOP FinRF Input Impedance Table⁽¹⁾

f_{FinRF} (MHz)	$ \Gamma $	Angle (Γ) (°)	Re {ZFinRF} (Ω)	Im {ZFinRF} (Ω)	ZFinRF (Ω)
100	0.86	-12.47	214.61	-314.33	380.61
200	0.85	-15.35	166.75	-270.14	317.46
300	0.84	-19.41	122.76	-228.38	259.28
400	0.83	-24.22	89.48	-193.48	213.17
500	0.82	-28.97	67.73	-167.98	181.12
600	0.82	-33.65	52.07	-148.64	157.50
700	0.82	-38.37	41.64	-131.88	138.30
800	0.82	-43.22	34.60	-117.36	122.35
900	0.81	-48.37	29.69	-104.33	108.47
1000	0.80	-53.84	25.88	-92.74	96.28
1100	0.79	-59.80	22.78	-82.21	85.31
1200	0.78	-66.29	20.17	-72.67	75.42
1300	0.77	-73.30	17.88	-64.06	66.51
1400	0.76	-80.74	15.93	-56.21	58.42
1500	0.75	-88.27	14.50	-49.36	51.45
1600	0.74	-95.87	13.27	-43.30	45.29
1700	0.73	-103.41	12.42	-37.96	39.94
1800	0.72	-110.77	11.67	-33.20	35.19
1900	0.71	-118.23	11.20	-28.78	30.88
2000	0.70	-125.46	11.25	-24.74	27.18
2100	0.68	-131.35	11.37	-21.60	24.41
2200	0.68	-137.19	10.94	-18.79	21.74
2300	0.68	-143.41	10.37	-15.88	18.97
2400	0.69	-149.45	9.70	-13.18	16.36
2500	0.71	-156.15	8.62	-10.26	13.40
2600	0.73	-163.87	7.79	-6.92	10.42
2700	0.74	-171.33	7.47	-3.71	8.34
2800	0.75	-178.24	7.30	0.76	7.34
2900	0.75	174.91	7.24	2.18	7.56
3000	0.75	168.09	7.33	5.12	8.94
3100	0.74	161.11	7.53	8.14	11.09
3200	0.74	153.92	7.83	11.30	13.75
3300	0.74	146.42	8.19	14.72	16.85
3400	0.74	138.67	8.59	18.36	20.27
3500	0.74	130.89	8.97	22.22	23.96
3600	0.75	123.33	9.30	26.23	27.83
3700	0.76	116.17	9.54	30.32	31.79
3800	0.77	109.55	9.74	34.42	35.77
3900	0.78	103.54	9.91	38.43	39.69
4000	0.79	98.25	10.20	42.23	43.44
4100	0.79	93.38	10.71	45.97	47.20
4200	0.79	88.86	11.70	49.59	50.95
4300	0.78	85.10	13.43	52.63	54.32
4400	0.77	82.09	14.79	55.23	57.18
4500	0.77	78.59	16.13	58.48	60.66
4600	0.76	74.73	17.90	62.30	64.82

(1) $V_{CC} = EN = 2.50V$, $T_A = +25^\circ C$

Table 1. LMX243x TSSOP FinRF Input Impedance Table⁽¹⁾ (continued)

f_{FinRF} (MHz)	$ \Gamma $	Angle (Γ) ($^{\circ}$)	Re {ZFinRF} (Ω)	Im {ZFinRF} (Ω)	ZFinRF (Ω)
4700	0.76	70.66	19.89	66.66	69.56
4800	0.75	66.05	22.50	72.05	75.48
4900	0.75	61.68	25.37	77.73	81.77
5000	0.75	57.35	28.56	84.19	88.90
5100	0.76	53.11	31.70	91.39	96.73
5200	0.77	48.79	34.78	100.34	106.20
5300	0.78	43.56	40.56	112.59	119.67
5400	0.78	38.11	52.53	125.62	136.16
5500	0.76	32.89	71.05	135.74	153.21
5600	0.73	27.85	95.57	142.32	171.43
5700	0.71	21.89	133.18	141.32	194.19
5800	0.68	15.38	177.08	116.75	212.10
5900	0.65	9.47	207.23	77.49	221.24
6000	0.64	4.15	222.92	35.24	225.69

Table 2. LMX243x ULGA FinIF Input Impedance Table⁽¹⁾

f_{FinIF} (MHz)	$ \Gamma $	Angle (Γ) ($^{\circ}$)	Re {ZFinIF} (Ω)	Im {ZFinIF} (Ω)	ZFinIF (Ω)
100	0.87	-6.19	446.34	-341.41	561.94
200	0.86	-8.10	353.77	-328.44	482.73
300	0.85	-10.98	257.50	-300.77	395.94
400	0.84	-14.21	188.33	-268.39	327.87
500	0.83	-17.67	141.63	-235.88	275.13
600	0.83	-21.32	109.44	-206.86	234.03
700	0.82	-25.13	86.57	-182.41	201.91
800	0.81	-29.04	70.47	-161.46	176.17
900	0.80	-32.99	58.90	-144.27	155.83
1000	0.79	-36.73	50.96	-130.45	140.05
1100	0.79	-40.28	44.21	-120.14	128.02
1200	0.79	-44.11	37.38	-111.08	117.20
1300	0.79	-48.38	31.82	-101.96	106.81
1400	0.79	-52.91	27.95	-93.09	97.20
1500	0.78	-57.26	25.34	-85.47	89.15
1600	0.77	-61.56	23.28	-78.74	82.11
1700	0.77	-66.01	20.98	-72.74	75.71
1800	0.77	-71.39	18.40	-66.32	68.83
1900	0.77	-77.74	15.22	-59.40	61.32
2000	0.76	-84.72	15.02	-52.48	54.59
2100	0.73	-92.59	14.39	-46.17	48.36
2200	0.71	-100.18	14.07	-40.46	42.84
2300	0.69	-107.33	13.94	-35.79	38.41
2400	0.68	-114.48	13.37	-31.55	34.27
2500	0.68	-118.42	12.71	-28.62	31.32

 (1) $V_{\text{CC}} = \text{EN} = 2.50\text{V}$, $T_{\text{A}} = +25^{\circ}\text{C}$

Table 3. LMX243x TSSOP FinIF Input Impedance Table⁽¹⁾

f_{FinIF} (MHz)	$ \Gamma $	Angle (Γ) (°)	Re {ZFinIF} (Ω)	Im {ZFinIF} (Ω)	ZFinIF (Ω)
100	0.87	-7.11	400.44	-348.14	530.62
200	0.86	-9.92	288.69	-318.81	430.10
300	0.85	-13.64	198.42	-281.45	344.36
400	0.84	-17.47	141.73	-246.13	284.02
500	0.84	-21.42	105.75	-214.58	239.22
600	0.83	-25.39	82.00	-188.43	205.50
700	0.83	-29.46	65.48	-166.34	178.76
800	0.82	-33.67	53.78	-147.46	156.96
900	0.81	-37.99	45.17	-131.83	139.35
1000	0.80	-42.47	38.82	-117.87	124.10
1100	0.79	-46.96	33.93	-106.36	111.64
1200	0.79	-51.67	29.53	-96.20	100.63
1300	0.78	-57.02	25.26	-86.47	90.08
1400	0.77	-63.11	22.15	-76.93	80.06
1500	0.76	-69.26	20.49	-68.42	71.42
1600	0.74	-74.82	19.54	-61.59	64.62
1700	0.74	-79.79	17.70	-56.35	59.06
1800	0.74	-86.55	15.09	-50.74	52.94
1900	0.74	-94.37	13.38	-44.56	46.53
2000	0.73	-101.95	12.62	-38.87	40.87
2100	0.72	-108.92	12.21	-34.18	36.30
2200	0.71	-115.63	11.65	-30.11	32.29
2300	0.71	-123.23	11.13	-25.97	28.25
2400	0.69	-131.44	11.08	-21.74	24.40
2500	0.67	-138.35	11.54	-18.31	21.64

(1) $V_{\text{CC}} = \text{EN} = 2.50\text{V}$, $T_{\text{A}} = +25^{\circ}\text{C}$

Table 4. LMX243x ULGA OSCin Input Impedance Table⁽¹⁾

f _{OSCin} (MHz)	ENosc = 1			ENosc = 0		
	Re {ZOSCin} (Ω)	Im {ZOSCin} (Ω)	ZOSCin (Ω)	Re {ZOSCin} (Ω)	Im {ZOSCin} (Ω)	ZOSCin (Ω)
5.0	5032.01	-10120.58	11302.53	2641.63	-13293.58	13553.50
7.5	2529.17	-7382.23	7803.46	1108.82	-8932.61	9001.17
10.0	1412.10	-5693.56	5866.06	526.74	-6461.11	6482.55
12.5	1051.18	-4930.80	5041.60	330.16	-5452.11	5462.10
15.0	710.63	-4099.58	4160.72	233.66	-4455.98	4462.10
17.5	545.87	-3584.60	3625.92	212.67	-3822.33	3828.24
20.0	442.32	-3125.21	3156.35	192.16	-3306.06	3311.64
22.5	314.15	-2806.10	2823.63	112.07	-2963.67	2965.79
25.0	316.48	-2518.94	2538.75	143.65	-2657.93	2661.81
27.5	223.49	-2280.02	2290.95	84.09	-2405.34	2406.81
30.0	196.90	-2105.11	2114.30	40.38	-2196.07	2196.45
32.5	175.38	-1942.45	1950.35	77.29	-2044.88	2046.34
35.0	158.95	-1816.83	1823.77	67.31	-1898.92	1900.12
37.5	137.80	-1701.59	1707.16	51.11	-1775.84	1776.58
40.0	114.20	-1573.28	1577.42	50.39	-1652.06	1652.83

 (1) V_{CC} = EN = 2.50V, T_A = +25°C

Table 5. LMX243x TSSOP OSCin Input Impedance Table⁽¹⁾

f _{OSCin} (MHz)	ENosc = 1			ENosc = 0		
	Re {ZOSCin} (Ω)	Im {ZOSCin} (Ω)	ZOSCin (Ω)	Re {ZOSCin} (Ω)	Im {ZOSCin} (Ω)	ZOSCin (Ω)
5.0	1111.30	-4814.09	4940.69	654.13	-7449.33	7477.99
7.5	628.81	-3411.80	3469.26	388.42	-5150.60	5165.22
10.0	359.99	-2623.46	2648.04	237.72	-3892.18	3899.44
12.5	284.12	-2065.00	2084.46	159.00	-2988.66	2992.88
15.0	203.53	-1801.24	1812.70	152.53	-2597.16	2601.63
17.5	134.32	-1548.50	1554.32	82.41	-2222.34	2223.86
20.0	109.85	-1343.30	1347.78	60.86	-1956.99	1957.94
22.5	80.56	-1192.73	1195.45	47.56	-1730.53	1731.18
25.0	69.37	-1063.72	1065.98	47.47	-1553.43	1554.15
27.5	60.10	-973.84	975.70	37.83	-1414.54	1415.04
30.0	50.30	-890.31	891.73	34.80	-1290.03	1290.50
32.5	45.52	-816.01	817.28	29.72	-1188.88	1189.25
35.0	41.55	-758.24	759.38	31.50	-1096.89	1097.35
37.5	37.73	-707.57	708.57	23.04	-1024.88	1025.14
40.0	36.09	-661.87	662.86	22.61	-963.11	963.38

 (1) V_{CC} = EN = 2.50V, T_A = +25°C

LMX243x Charge Pump Test Setup

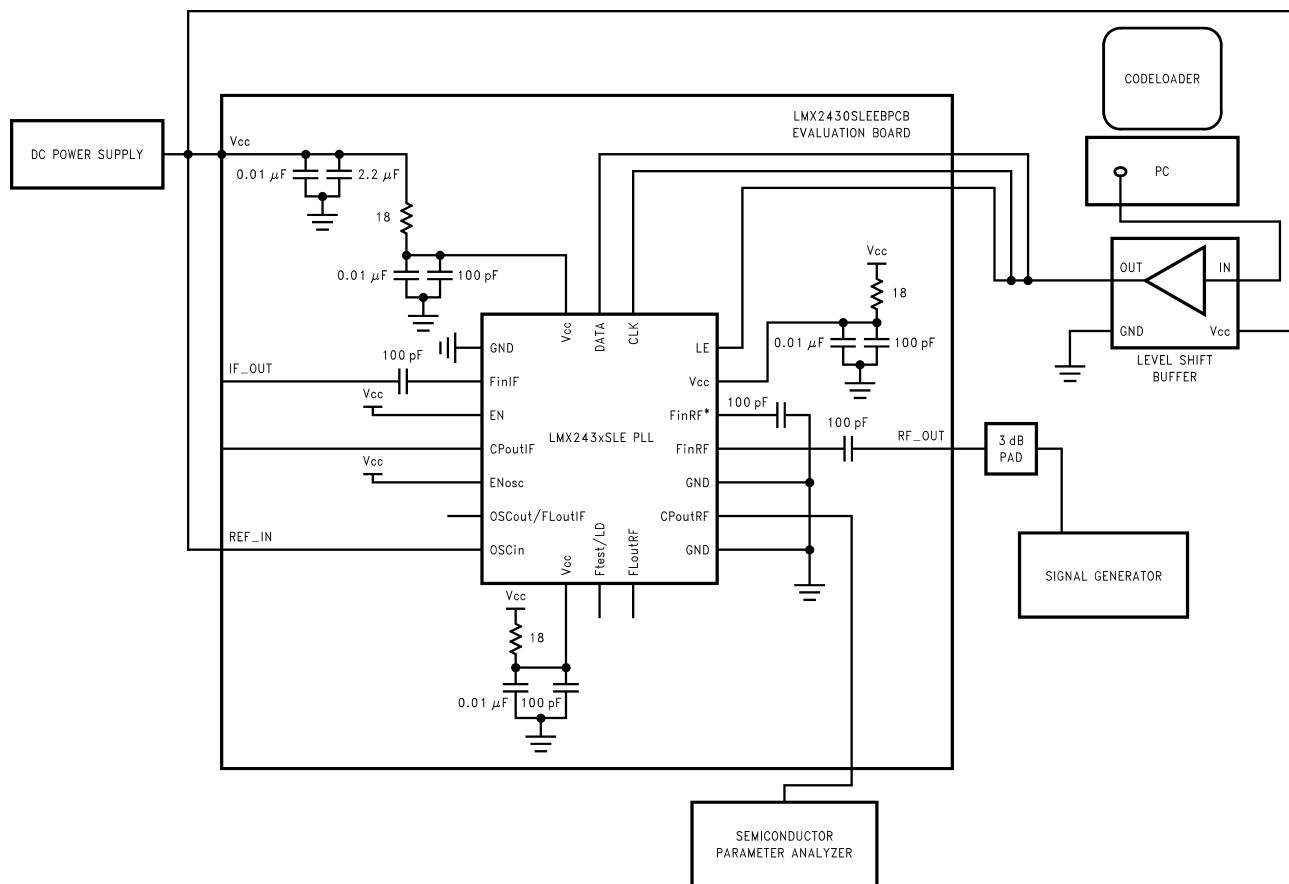

Figure 31.

The block diagram above illustrates the setup required to measure the LMX243x device's RF charge pump sink current. The same setup is used for the LMX2430PW Evaluation Board. The purpose of this test is to assess the functionality of the RF charge pump. The IF charge pump is evaluated in the same way.

This setup uses an open loop configuration. A power supply is connected to Vcc. By means of a signal generator, a 10 MHz signal is typically applied to the FinRF pin. The signal is one of two inputs to the phase/frequency detector (PFD). The 3 dB pad provides a 50Ω match between the PLL and the signal generator. The OSCin pin is tied to Vcc. This establishes the other input to the PFD. Alternatively, this input can be tied directly to the ground plane. The EN and ENosc pins are also both tied to Vcc. A Semiconductor Parameter Analyzer is connected to the CPoutRF pin and used to measure the sink, source, and TRI-STATE leakage currents.

Let F_r represent the frequency of the signal applied to the OSCin pin, which is simply zero in this case (DC), and let F_p represent the frequency of the signal applied to the FinRF pin. The PFD is sensitive to the rising edges of F_r and F_p . Assuming positive VCO characteristics (RF_CPP bit = 1); the charge pump turns ON, and sinks current when the first rising edge of F_p is detected. Since F_r has no rising edge, the charge pump continues to sink current indefinitely. In order to measure the RF charge pump source current, the RF_CPP bit is simply set to 0 (negative VCO characteristics) in CodeLoader. Similarly, in order to measure the TRI-STATE leakage current, the RF_CPT bit is set to 1.

The measurements are typically taken over supply voltage and temperature. The measurements are also typically taken at the HIGH and LOW charge pump current gains. The charge pump current gain can be controlled by the RF_CPG bit in CodeLoader. Once the charge pump currents are determined, the (i) charge pump output current magnitude variation versus charge pump output voltage, (ii) charge pump output sink current versus charge pump output source current mismatch, and (iii) charge pump output current magnitude versus temperature, can be calculated. Refer to the [Charge Pump Current Specifications Definition](#) for more details.

LMX243x FinRF Sensitivity Test Setup

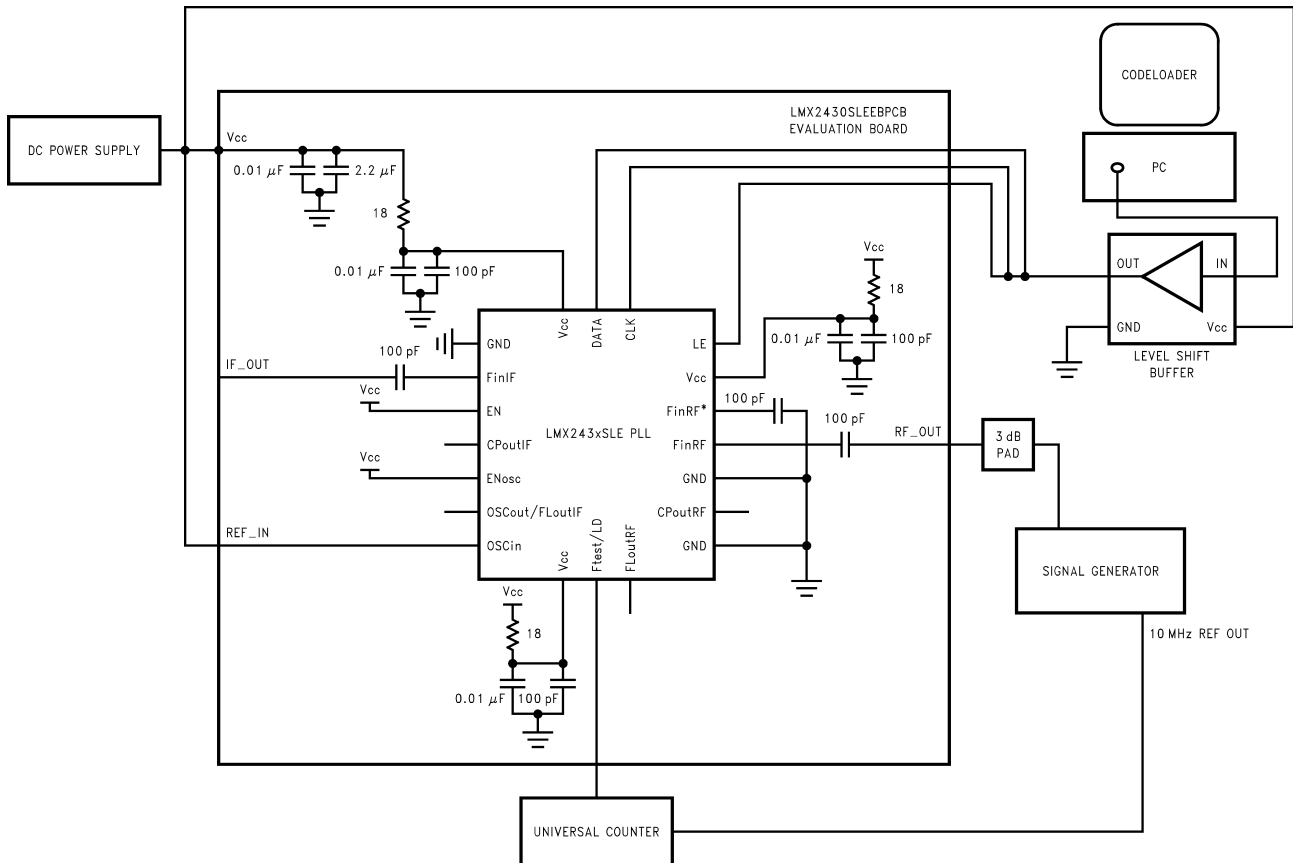

Figure 32.

The block diagram above illustrates the setup required to measure the LMX243x device's RF input sensitivity level. The same setup is used for the LMX2430PW Evaluation Board. The purpose of this test is to measure the acceptable signal level to the FinRF input of the PLL chip. Outside the acceptable signal range, the feedback divider begins to divide incorrectly and miscount the frequency. The FinIF sensitivity is evaluated in the same way.

The setup uses an open loop configuration. A power supply is connected to Vcc. The IF PLL is powered down (IF_PD bit = 1). By means of a signal generator, an RF signal is applied to the FinRF pin. The 3 dB pad provides a 50Ω match between the PLL and the signal generator. The EN, ENosc, and OSCin pins are all tied to Vcc. The N value is typically set to 10000 in CodeLoader, i.e. RF_B word = 156 and RF_A word = 16 for RF_P bit = 0 (LMX2434) or RF_P bit = 1 (LMX2430 and LMX2433). The feedback divider output is routed to the Ftest/LD pin by selecting the RF_N/2 Frequency word (MUX[3:0] word = 15) in CodeLoader. A Universal Counter is connected to the Ftest/LD pin and used to monitor the output frequency of the feedback divider. The expected frequency should be the signal generator frequency divided by twice the corresponding counter value, i.e. 20000. The factor of two comes in because the LMX43x device has an internal /2 circuit which is used to provide a 50% duty cycle.

Sensitivity is typically measured over frequency, supply voltage and temperature. In order to perform the measurement, the temperature, frequency, and supply voltage is set to a fixed value and the power level of the signal at FinRF is varied. Sensitivity is reached when the frequency error of the divided RF input is greater than or equal to 1 Hz. The power attenuation from the cable and the 3 dB pad must be accounted for. The feedback divider will actually miscount if too much or too little power is applied to the FinRF input. Therefore, the allowed input power level will be bounded by the upper and lower sensitivity limits. In a typical application, if the power level to the FinRF input approaches the sensitivity limits, this can introduce spurs or cause degradation to the phase noise. When the power level gets even closer to these limits, or exceeds it, then the RF PLL loses lock.

LMX243x OSCin Sensitivity Test Setup

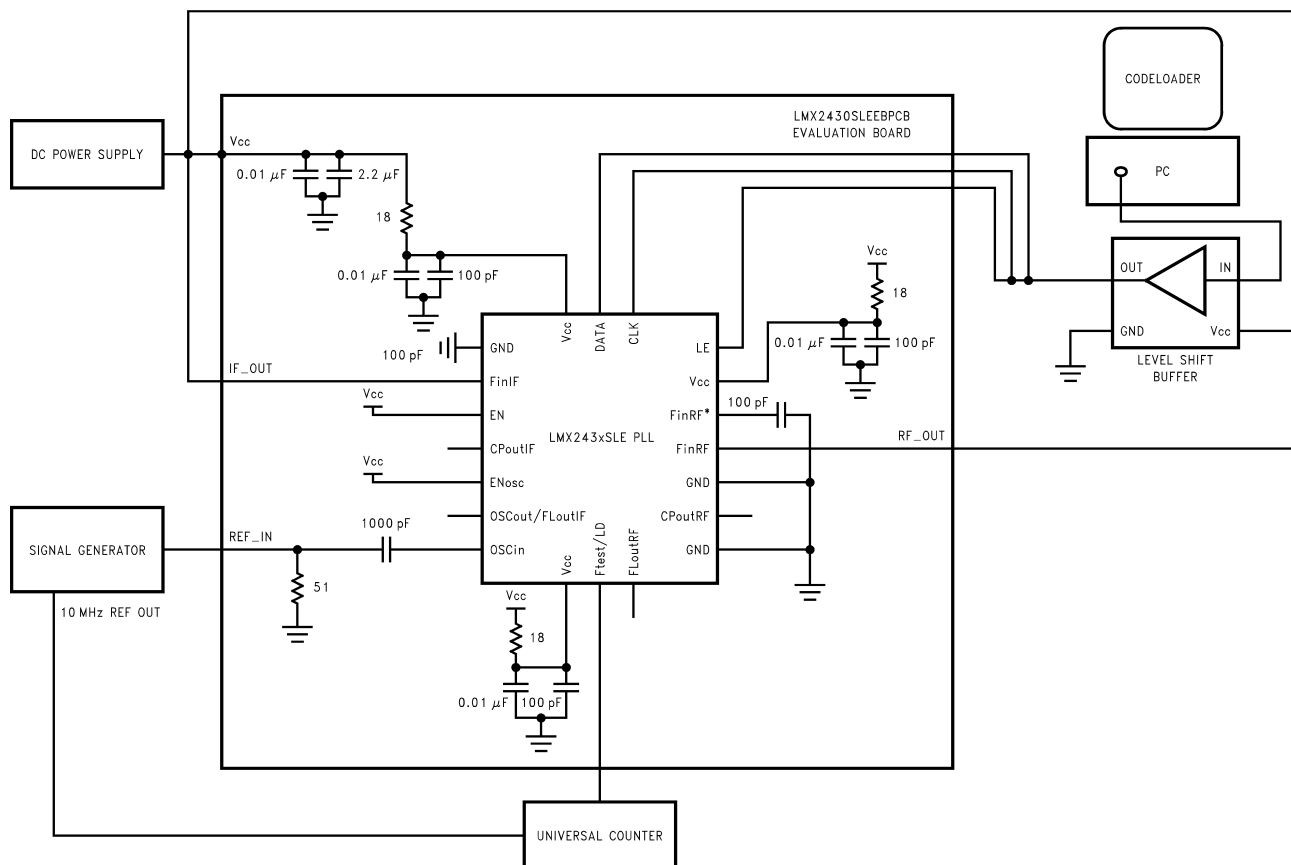

Figure 33.

The block diagram above illustrates the setup required to measure the LMX243x device's OSCin buffer sensitivity level. The same setup is used for the LMX2430PW Evaluation Board. This setup is similar to the FinRF sensitivity setup except that the signal generator is now connected to the OSCin pin and both Fin pins are tied to Vcc. The 51Ω shunt resistor matches the OSCin input to the signal generator. The R counter is typically set to 1000, i.e. RF_R word = 1000 or IF_R word = 1000. The reference divider output is routed to the Ftest/LD pin by selecting the RF_R/ 2 Frequency word (MUX[3:0] word = 14) or the IF_R/ 2 Frequency word (MUX[3:0] word = 12) in CodeLoader. A Universal Counter is connected to the Ftest/LD pin and is used to monitor the output frequency of the reference divider. The expected frequency should be the signal generator frequency divided by twice the corresponding counter value, i.e. 2000. The factor of two comes in because the LMX243x device has an internal /2 circuit which is used to provide a 50% duty cycle.

In a similar way, sensitivity is typically measured over frequency, supply voltage and temperature. In order to perform the measurement, the temperature, frequency, and supply voltage is set to a fixed value and the power level (voltage level) of the signal at OSCin is varied. Sensitivity is reached when the frequency error of the divided input signal is greater than or equal to 1 Hz.

LMX243x FinRF Input Impedance Test Setup

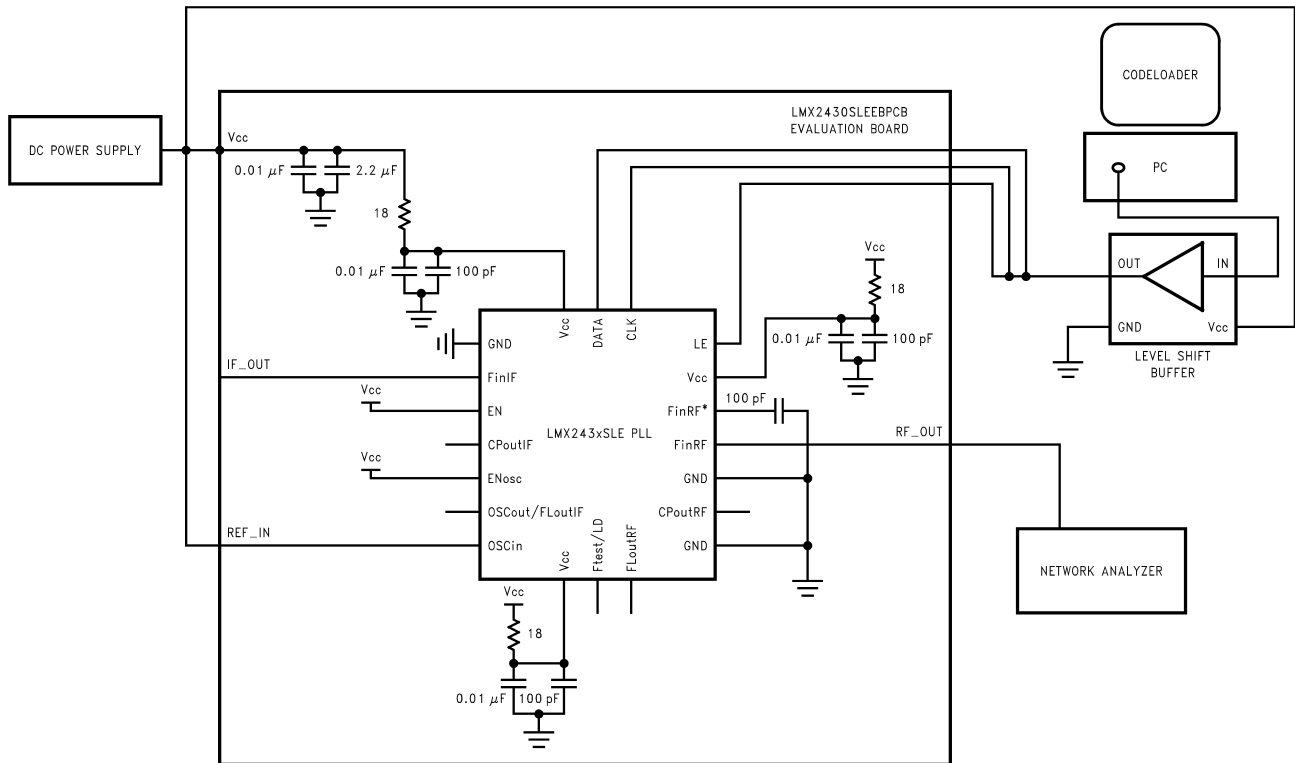

Figure 34.

The block diagram above illustrates the setup required to measure the LMX243x device's RF input impedance. The same setup is used for the LMX2430PW Evaluation Board. Measuring the device's input impedance facilitates the design of appropriate matching networks to match the PLL to the VCO, or in more critical situations, to the characteristic impedance of the printed circuit board (PCB) trace, to prevent undesired transmission line effects. The FinIF input impedance is evaluated in the same way.

Before the actual measurements are taken, the Network Analyzer needs to be calibrated, i.e. the error coefficients need to be calculated. The Network Analyzer's calibration standard is used to calculate these coefficients. The calibration standard includes an open, short and a matched load. A 1-port calibration is implemented here.

To calculate the coefficients, the PLL chip is first removed from the PCB. A piece of semi-rigid coaxial cable is then soldered to the pad on the PCB which is equivalent to the FinRF pin on the PLL chip. Proper grounding near the exposed tip of the semi-rigid coaxial cable is required for accurate results. Note that the DC blocking capacitor is removed for this test. The Network Analyzer port is then connected to the other end of the semi-rigid coaxial cable. In this way, the semi-rigid coaxial cable acts as a transmission line. This transmission line adds electrical length and produces an offset from the reference plane of the Network Analyzer; therefore, it must be included in the calibration. The desired operating frequency is then set. The typical frequency range selected for the LMX243x device's RF synthesizer is from 100 MHz to 6000 MHz.

The Network Analyzer calculates the calibration coefficients based on the measured S_{11} parameters. With this all done, calibration is now complete.

The PLL chip is then placed on the PCB. A power supply is then connected to Vcc. The EN, ENosc, and OSCin pins are all tied to Vcc. Alternatively, the OSCin pin can be tied to ground. In this setup, the complementary input (FinRF*) is AC coupled to ground. With the Network Analyzer still connected to the semi-rigid coaxial cable, the measured FinRF impedance is displayed.

The OSCin input impedance is measured in the same way. The impedance is measured when the oscillator buffer is powered up (ENosc is set HIGH) and when the oscillator buffer is powered down (ENosc pin is set LOW).

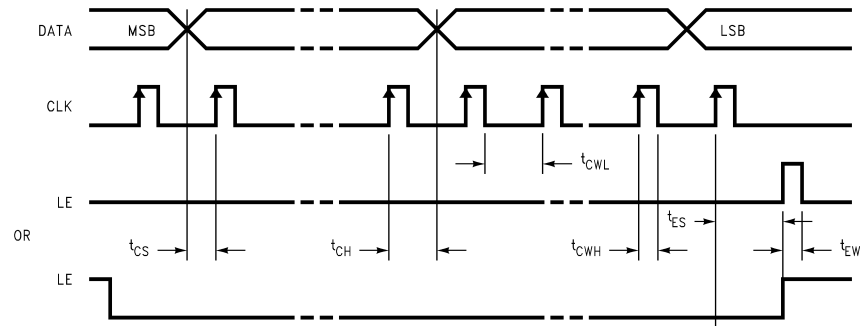

Notes:

1. DATA is clocked into the 24-bit shift register on the rising edge of CLK
2. The MSB of DATA is shifted in first.

Figure 35. LMX243x Serial Data Input Timing

FUNCTIONAL DESCRIPTION

The basic phase-lock-loop (PLL) configuration consists of a high-stability crystal reference oscillator, a frequency synthesizer such as the LMX243x, a voltage controlled oscillator (VCO), and a passive loop filter. The frequency synthesizer includes a phase detector, current mode charge pump, programmable reference R and feedback N frequency dividers. The VCO frequency is established by dividing the crystal reference signal down via the reference divider to obtain a comparison reference frequency. This reference signal, f_r , is then presented to the input of a phase/ frequency detector and compared with the feedback signal, f_p , which was obtained by dividing the VCO frequency down by way of the feedback divider. The phase/ frequency detector measures the phase error between the f_r and f_p signals and outputs control signals that are directly proportional to the phase error. The charge pump then pumps charge into or out of the loop filter based on the magnitude and direction of the phase error. The loop filter converts the charge into a stable control voltage for the VCO. The phase/frequency detector's function is to adjust the voltage presented to the VCO until the feedback signal's frequency and phase match that of the reference signal. When this "Phase-Locked" condition exists, the VCO frequency will be N times that of the comparison frequency, where N is the feedback divider ratio.

REFERENCE OSCILLATOR INPUT

The reference oscillator frequency for both the RF and IF PLLs is provided from an external reference via the OSCin pin. The reference buffer circuit supports input frequencies from 5 to 40 MHz with a minimum input sensitivity of $0.5 V_{PP}$. The reference buffer circuit has an approximate $V_{CC}/2$ input threshold and can be driven from an external AC coupled source. Typically, the OSCin pin is connected to the output of a crystal oscillator.

REFERENCE DIVIDERS (R COUNTERS)

The reference dividers divide the reference input signal, OSCin, by a factor of R. The output of the reference divider circuits feeds the reference input of the phase detector. This reference input to the phase detector is often referred to as the comparison frequency. The divide ratio should be chosen such that the maximum phase comparison frequency (f_{COMPRF} or f_{COMPIF}) of 10 MHz is not exceeded.

The RF and IF reference dividers are each comprised of 15-bit CMOS binary counters that support a continuous integer divide ratio from 3 to 32767. The RF and IF reference divider circuits are clocked by the output of the reference buffer circuit which is common to both. Refer to [RF_R\[14:0\] - RF Synthesizer Programmable Reference Divider \(R Counter\) \(R0\[17:3\]\)](#) and [IF_R\[14:0\] - IF Synthesizer Programmable Reference Divider \(R Counter\) \(R3\[17:3\]\)](#) for details on how to program the RF_R and IF_R counters.

PRESCALERS

The FinRF and FinIF input pins drive the input of a differential-pair amplifier. The output of the differential-pair amplifier drives a chain of D-type flip-flops in a dual modulus configuration. The output of the prescaler is used to clock the subsequent feedback dividers. The RF PLL complementary inputs can be driven differentially, or the negative input can be AC coupled to ground through an external capacitor for single ended configuration. A 16/17 or a 32/33 prescale ratio can be selected for the 5.0 GHz LMX2434 RF synthesizer. An 8/9 or a 16/17 prescale ratio can be selected for both the LMX2430 and LMX2433 RF synthesizers. The IF PLL is single ended. An 8/9 or a 16/17 prescale ratio can be selected for the IF synthesizer.

PROGRAMMABLE FEEDBACK DIVIDERS (N COUNTERS)

The programmable feedback dividers operate in concert with the prescalers to divide the input signal, Fin, by a factor of N. The output of the programmable reference divider is provided to the feedback input of the phase detector circuit. The divide ratio should be chosen such that the maximum phase comparison frequency (f_{COMPRF} or f_{COMPIF}) of 10 MHz is not exceeded.

The programmable feedback divider circuit is comprised of an A counter (swallow counter) and a B counter (programmable binary counter). For both the LMX2430 and LMX2433, the RF_A counter is a 4-bit swallow counter, programmable from 0 to 15. The LMX2434 RF_A counter is a 5-bit swallow counter, programmable from 0 to 31. The LMX243x IF_A counter is a 4-bit swallow counter, programmable from 0 to 15. For both the LMX2430 and LMX2433, the RF_B counter is a 15-bit binary counter, programmable from 3 to 32767. The LMX2434 RF_B counter is a 14-bit binary counter, programmable from 3 to 16383. The LMX243x IF_B is a 14-bit binary counter programmable from 3 to 16383. A continuous integer divide ratio is achieved if $N \geq P * (P-1)$, where P is the value of the prescaler selected.

Divide ratios less than the minimum continuous divide ratio are achievable as long as the binary programmable counter value is greater than the swallow counter value ($B \geq A$). Refer to [RF_A\[3:0\] - LMX2430/33 RF Synthesizer Swallow Counter \(A Counter\) \(R1\[6:3\]\)](#), [RF_A\[4:0\] - LMX2434 RF Synthesizer Swallow Counter \(A Counter\) \(R1\[7:3\]\)](#), [RF_B\[14:0\] - LMX2430/33 RF Synthesizer Programmable Binary Counter \(B Counter\) \(R1\[21:7\]\)](#), [RF_B\[13:0\] - LMX2434 RF Synthesizer Programmable Binary Counter \(B Counter\) \(R1\[21:8\]\)](#), [IF_A\[3:0\] - IF Synthesizer Swallow Counter \(A Counter\) \(R4\[6:3\]\)](#), and [IF_B\[13:0\] - IF Synthesizer Programmable Binary Counter \(B Counter\) \(R4\[20:7\]\)](#) for details on how to program the A and B counters. The following equations are useful in determining and programming a particular value of N:

$$N = (P \times B) + A$$

$$f_{in} = N \times f_{COMP}$$

Definitions:

- f_{COMP}**: RF or IF phase detector comparison frequency
- f_{in}**: RF or IF input frequency
- A**: RF_A or IF_A counter value
- B**: RF_B or IF_B counter value
- P**: Preset modulus of the dual modulus prescaler
 - LMX2430 RF synthesizer: P = 8 or 16
 - LMX2433 RF synthesizer: P = 8 or 16
 - LMX2434 RF synthesizer: P = 16 or 32
 - LMX243x IF synthesizer: P = 8 or 16

PHASE/ FREQUENCY DETECTORS

The RF and IF phase/ frequency detectors (PFD) are driven from their respective N and R counter outputs. The maximum frequency for both the RF and IF phase detector inputs is 10 MHz. The PFD outputs control the respective charge pumps. The polarity of the pump-up or pump-down control signals are programmed using the **RF_CPP** or **IF_CPP** control bits, depending on whether the RF or IF VCO characteristics are positive or negative. Refer to [RF_CPP - RF Synthesizer Phase Detector Polarity \(R0\[18\]\)](#) and [IF_CPP - IF Synthesizer Phase Detector Polarity \(R3\[18\]\)](#) for more details. The PFDs have a detection range of -2π to $+2\pi$. The PFDs also receive a feedback signal from the charge pump in order to eliminate dead zone.

Phase Comparator and Internal Charge Pump Characteristics

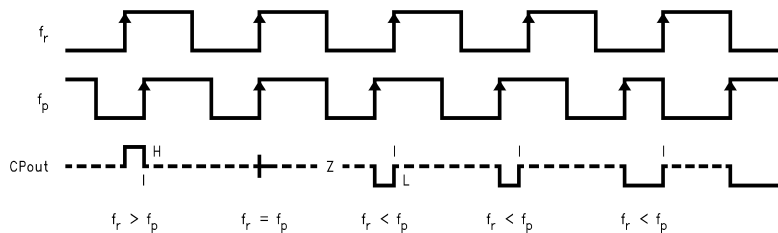

Notes:

1. The minimum width of the pump-up and pump-down current pulses occur at the CPoutRF or CPoutIF pins when the loop is phase locked.
2. The diagram assumes positive VCO characteristics, i.e. RF_CPP or IF_CPP = 1.
3. f_r is the PFD input from the reference divider (R counter).
4. f_p is the PFD input from the programmable feedback divider (N counter).
5. CPout refers to either the RF or IF charge pump output.

CHARGE PUMPS

The charge pump directs charge into or out of an external loop filter. The loop filter converts the charge into a stable control voltage which is applied to the tuning input of the VCO. The charge pump steers the VCO control voltage towards V_{cc} during pump-up events and towards GND during pump-down events. When locked, CPoutRF or CPoutIF are primarily in a TRI-STATE mode with small corrections occurring at the phase comparator rate. The charge pump output current magnitude can be selected by toggling the **RF_CPG** or **IF_CPG** control bits.

MICROWIRE SERIAL INTERFACE

The programmable register set is accessed via the MICROWIRE serial interface. A low voltage logic interface allows direct connection to 1.8V devices. The interface is comprised of three signal pins: CLK, DATA and LE. Serial data is clocked into the 24-bit shift register on the rising edge of CLK. The last two bits decode the internal control register address. When LE transitions HIGH, DATA stored in the shift register is loaded into one of four control registers depending on the state of the address bits. The MSB of DATA is loaded in first. The synthesizers can be programmed even in power down mode. A complete programming description is provided in [Programming Description](#).

MULTI-FUNCTION OUTPUTS

The LMX243x device's Ftest/LD output pin is a multi-function output that can be configured as a general purpose CMOS TRI-STATE output, push-pull analog lock detect output, open-drain analog lock detect output, digital filtered lock detect output, or used to monitor the output of the various reference divider (R counter) or feedback divider (N counter) circuits. The Ftest/LD control word is used to select the desired output function. When the PLL is in powerdown mode, the Ftest/LD output is disabled and is in a high impedance state. A complete programming description of the multi-function output is provided in [MUX\[3:0\] - MULTIFUNCTION OUTPUT SELECT \(R3\[23:22\]:R0\[23:22\]\)](#).

Push-Pull Analog Lock Detect Output

An analog lock detect status generated from the phase detector is available on the Ftest/LD output pin if selected. A push-pull configuration can be selected for the lock detect output signal. With this configuration, the lock detect output goes HIGH when the charge pump is inactive. It goes LOW when the charge pump is active during a comparison cycle. Narrow low going pulses are observed when the charge pump turns on.

There are three separate push-pull analog lock detect signals that are routed to the multiplexer. Two of these monitor the lock status of the individual synthesizers. The third detects the condition when both the RF and IF synthesizers are in a locked state. External circuitry is required to provide a steady DC signal to indicate when the PLL is in a locked state. Refer to [MUX\[3:0\] - MULTIFUNCTION OUTPUT SELECT \(R3\[23:22\]:R0\[23:22\]\)](#) for details on how to program the different push-pull analog lock detect options.

Open-Drain Analog Lock Detect Output

The lock detect output can be an open-drain configuration. In this configuration, the lock detect output goes to a high impedance state when the charge pump is inactive. It goes LOW when the charge pump is active during a comparison cycle. When a pull-up resistor is used, narrow low going pulses are observed when the charge pump turns on.

Similarly, three separate open-drain analog lock detect signals are routed to the multiplexer. Two of these monitor the lock status of the individual synthesizers. The third detects the condition when both the RF and IF synthesizers are in a locked state. External circuitry is required to provide a steady DC signal to indicate when the PLL is in a locked state. Refer to [MUX\[3:0\] - MULTIFUNCTION OUTPUT SELECT \(R3\[23:22\]:R0\[23:22\]\)](#) for details on how to program the different open-drain analog lock detect options.

Digital Filtered Lock Detect Output

A digital filtered lock detect status generated from the phase detector is also available on the Ftest/LD output pin if selected. The lock detect digital filter compares the difference between the phases of the inputs to the PFD to an RC generated delay of approximately 15 ns. If the phase error is less than the 15 ns RC delay for 5 consecutive reference cycles, the PLL enters a locked state (HIGH). Once in lock, the RC delay is changed to approximately 30 ns. Once the phase error becomes greater than the 30 ns RC delay, the PLL falls out of lock (LOW). When the PLL is in powerdown mode, the Ftest/LD output is forced LOW. A flow chart of the digital filtered lock detect output is shown below.

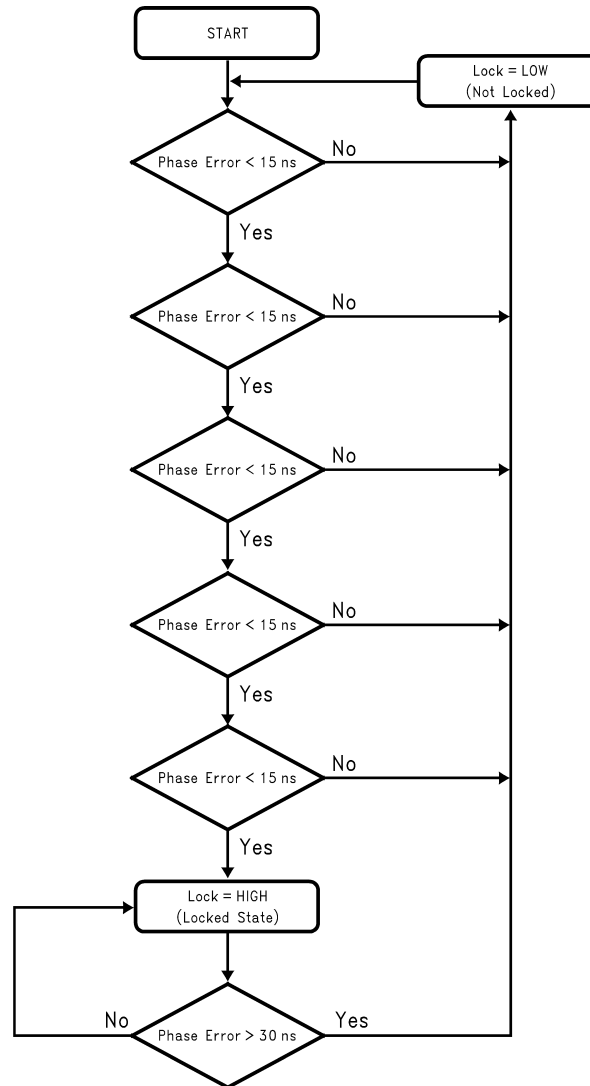

Similarly, three separate digital filtered lock detect signals are routed to the multiplexer. Two of these monitor the lock status of the individual synthesizers. The third detects the condition when both the RF and IF synthesizers are in a locked state. External circuitry is not required when the digital filtered lock detect option is selected. Refer to [MUX\[3:0\] - MULTIFUNCTION OUTPUT SELECT \(R3\[23:22\]:R0\[23:22\]\)](#) for details on how to program the different digital filtered lock detect options.

Reference Divider and Feedback Divider Output

The outputs of the various N and R dividers can be monitored by selecting the appropriate Ftest/LD word. This is essential when performing OSCin or Fin sensitivity measurements. Refer to the [LMX243x FinRF Sensitivity Test Setup](#) or [LMX243x OSCin Sensitivity Test Setup](#) sections for more details. Note, the R and N outputs that are routed to the Ftest/LD are R/2 and N/2 respectively. The internal /2 circuit is used to provide a 50% duty cycle. Refer to [MUX\[3:0\] - MULTIFUNCTION OUTPUT SELECT \(R3\[23:22\]:R0\[23:22\]\)](#) for more details on how to route the appropriate divider output to the Ftest/LD pin.

FASTLOCK OUTPUT

The LMX243x Fastlock feature allows a faster loop response time during lock acquisition. The loop response time (lock time) can be approximately halved if the loop bandwidth is doubled. In order to achieve this, the same gain/phase relationship should be maintained when the loop bandwidth is doubled. When the FLoutRF or OSCout/FLoutIF pins are configured as FastLock outputs, an open drain device is enabled. The open drain device switches in a resistor parallel, and of equal value, to R2 of the external loop filter.

The loop bandwidth is effectively doubled and stability is maintained. Once locked to the correct frequency, the PLL will return to a steady state condition. The LMX243x offers two methods to achieve Fastlock: manual and automatic. Manual Fastlock is achieved by increasing the charge pump current from 1 mA (RF_CPG/ IF_CPG Bit = 0) in the steady state mode, to 4 mA (RF_CPG/ IF_CPG Bit = 1) in Fastlock mode. Automatic Fastlock is achieved by programming the timeout counter register (RF_TOC/ IF_TOC) with the appropriate number of phase comparison cycles that the RF/ IF synthesizer will spend in the Fastlock state. Refer to [R2 REGISTER](#) and [R5 REGISTER](#) for details on how to configure the FLoutRF or OSCout/ FLoutIF output to an open drain Fastlock output.

COUNTER RESET

When the RF_RST/ IF_RST bit is enabled, both the feedback divider (RF_N/ IF_N) and reference divider (RF_R/ IF_R) are held at their load point. When the device is programmed to normal operation, both the feedback divider and reference divider are enabled and resume counting in close alignment to each other. Refer to [RF_RST - RF Synthesizer Counter Reset \(R0\[21\]\)](#) and [IF_RST - IF Synthesizer Counter Reset \(R3\[21\]\)](#) for more details.

POWER CONTROL

The LMX243x device can be asynchronously powered down when the EN pin is set LOW, independent of the state of the powerdown bits. Note that the OSCout/ FLoutIF pin can still be enabled if the ENosc pin is set HIGH, independent of the state of the EN pin. This capability allows the oscillator buffer to be used as a crystal oscillator. When EN is set HIGH, powerdown is controlled through the MICROWIRE. The powerdown word is comprised of the [RF_PD/ IF_PD](#) bit, in conjunction with the [RF_CPT/ IF_CPT](#) bit. The powerdown control word is used to set the operating mode of the device. Refer to [RF_CPT - RF Synthesizer Charge Pump TRI-STATE \(R0\[20\]\)](#), [RF_PD - RF Synthesizer Powerdown \(R1\[23\]\)](#), [IF_CPT - IF Synthesizer Charge Pump TRI-STATE \(R3\[20\]\)](#), and [IF_PD - IF Synthesizer Powerdown \(R4\[23\]\)](#) for details on how to program the RF or IF powerdown bits.

When either synthesizer is powered down, the respective prescaler, phase detector, and charge pump circuit is disabled. The CPoutRF/ CPoutIF, FinRF/ FinIF, and FinRF* pins are all forced to a high impedance state. The reference divider and feedback divider circuits are held at the load point during powerdown. The oscillator buffer is disabled when the ENosc pin is set LOW. The OSCin pin is forced to a HIGH state through an approximate 100 kΩ resistance when this condition exists. When either synthesizer is activated, the respective prescaler, phase detector, charge pump circuit, and the oscillator buffer are all powered up. The feedback divider and reference divider are held at their load point. This allows the reference oscillator, feedback divider, reference divider and prescaler circuitry to reach proper bias levels. After a finite delay, the feedback and reference dividers are enabled and they resume counting in close alignment (the maximum error is one prescaler cycle). The MICROWIRE control register remains active and capable of loading and latching data while in powerdown mode.

Synchronous Powerdown Mode

In this mode, the powerdown function is gated by the charge pump. When the device is configured for synchronous powerdown, the device will enter the powerdown mode upon completion of the next charge pump pulse event.

Asynchronous Powerdown Mode

In this mode, the powerdown function is NOT gated by the completion of a charge pump pulse event. When the device is configured for asynchronous powerdown, the part will go into powerdown mode immediately.

EN Pin	RF_CPT/ IF_CPT Bit	RF_PD/ IF_PD Bit	Operating Mode
0	X ⁽¹⁾	X ⁽¹⁾	Asynchronous Powerdown
1	0	0	PLL Active. Normal Operation
1	1	0	PLL Active. Charge Pump Output in High Impedance State
1	0	1	Synchronous Powerdown
1	1	1	Asynchronous Powerdown

(1) **Note:** X refers to a don't care condition.

Programming Description

MICROWIRE INTERFACE

The 24-bit shift register is loaded via the MICROWIRE interface. The shift register consists of a 21-bit *DATA[20:0] FIELD* and a 3-bit *ADDRESS[2:0] FIELD* as shown below. The ADDRESS FIELD is used to decode the internal control register address. When LE transitions HIGH, DATA stored in the shift register is loaded into one of 6 control registers depending on the state of the ADDRESS bits. The MSB of DATA is loaded into the shift register first. The DATA FIELD assignments are shown in [CONTROL REGISTER CONTENT MAP](#).

MSB	LSB
DATA[20:0]	ADDRESS[2:0]
23	0

CONTROL REGISTER LOCATION

The ADDRESS[2:0] bits decode the internal register address. The table below shows how the ADDRESS bits are mapped into the target control register.

ADDRESS[2:0] FIELD			Target Register
0	0	0	R0
0	0	1	R1
0	1	0	R2
0	1	1	R3
1	0	0	R4
1	0	1	R5

CONTROL REGISTER CONTENT MAP

The control register content map describes how the bits within each control register are allocated to specific control functions. The bits that are marked 0 should be programmed as such to ensure proper device operation.

Reg	23	22	21	20	19	18	17	16	15	14	13	12	11	10	9	8	7	6	5	4	3	2	1	0
	DATA[20:0] FIELD																				ADDRESS [2:0] FIELD			
R0	MUX[3:2]			RF RS T	RF CP T	RF CP G	RF CP P	RF_R[14:0]														0	0	0
R1	RF PD	RF P	LMX2430/33 RF_B[14:0]														LMX2430/33 RF_A[3:0]			0	0	1		
R1	RF PD	RF P	LMX2434 RF_B[13:0]														LMX2434 RF_A[4:0]			0	0	1		
R2	0	0	0	0	0	0	0	0	0	0	RF_TOC[11:0]											0	1	0
R3	MUX[1:0]		IF RS T	IF CP T	IF CP G	IF CP P	IF_R[14:0]														0	1	1	
R4	IF PD	IF P	0	IF_B[13:0]														IF_A[3:0]			1	0	0	
R5	0	0	0	0	0	0	0	0	0	0	IF_TOC[11:0]											1	0	1

R0 REGISTER

The R0 register contains the RF_R, RF_CPP, RF_CPG, RF_CPT, and RF_RST control words, in addition to two of the four bits that compose the MUX control word. The detailed descriptions and programming information for each control word is discussed in the following sections.

Reg	23	22	21	20	19	18	17	16	15	14	13	12	11	10	9	8	7	6	5	4	3	2	1	0	
	DATA[20:0] FIELD																					ADDRESS [2:0] FIELD			
R0	MUX[3:2]			RF RS T	RF CP T	RF CP G	RF CP P	RF_R[14:0]															0	0	0

RF_R[14:0] - RF Synthesizer Programmable Reference Divider (R Counter) (R0[17:3])

The RF reference divider (RF_R) can be programmed to support divide ratios from 3 to 32767. Divide ratios less than 3 are prohibited.

Divide Ratio	RF_R[14:0]															
	14	13	12	11	10	9	8	7	6	5	4	3	2	1	0	
3	0	0	0	0	0	0	0	0	0	0	0	0	0	0	1	1
4	0	0	0	0	0	0	0	0	0	0	0	0	0	1	0	0
•	•	•	•	•	•	•	•	•	•	•	•	•	•	•	•	•
32767	1	1	1	1	1	1	1	1	1	1	1	1	1	1	1	1

RF_CPP - RF Synthesizer Phase Detector Polarity (R0[18])

The RF_CPP bit is used to control the RF synthesizer's phase/ frequency detector polarity based on the VCO tuning characteristics.

Control Bit	Register Location	Description	Function	
			0	1
RF_CPP	R0[18]	RF Phase/ Frequency Detector Polarity	RF VCO Negative Tuning Characteristics	RF VCO Positive Tuning Characteristics

Figure 36. RF VCO Characteristics

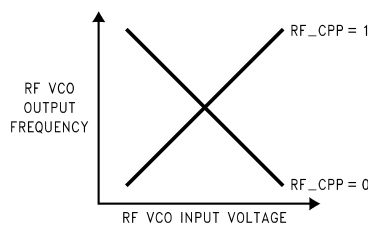

RF_CPG - RF Synthesizer Charge Pump Current Gain (R0[19])

The RF_CPG bit controls the RF synthesizer's charge pump gain. Two gain levels are available.

Control Bit	Register Location	Description	Function	
			0	1
RF_CPG	R0[19]	RF Charge Pump Current Gain	LOW 1 mA	HIGH 4 mA

RF_CPT - RF Synthesizer Charge Pump TRI-STATE (R0[20])

The RF_CPT bit allows the charge pump to be switched between a normal operating mode and a high impedance output state. This happens asynchronously with the change in the RF_CPT bit.

Furthermore, the RF_CPT bit operates in conjunction with the RF_PD bit to set a synchronous or an asynchronous powerdown mode. Refer to [RF_PD - RF Synthesizer Powerdown \(R1\[23\]\)](#) for more details on how to program the RF_PD bit.

Control Bit	Register Location	Description	Function	
			0	1
RF_CPT	R0[20]	RF Charge Pump TRI-STATE	RF Charge Pump Normal Operation	RF Charge Pump Output in High Impedance State

RF_RST - RF Synthesizer Counter Reset (R0[21])

The RF_RST bit resets the RF_A, RF_B and RF_R counters. After removing the reset, the RF_A and RF_B counters resume counting in close alignment with the RF_R counter. The maximum error is one prescaler cycle.

Control Bit	Register Location	Description	Function	
			0	1
RF_RST	R0[21]	RF Counter Reset	RF_A, RF_B and RF_R Normal Operation	RF_A, RF_B and RF_R Reset

R1 REGISTER

The R1 register contains the RF_A, RF_B, RF_P, and RF_PD control words. The RF_A and RF_B control words are used to setup the programmable feedback divider. The detailed descriptions and programming information for each control word is discussed in the following sections.

Reg	23	22	21	20	19	18	17	16	15	14	13	12	11	10	9	8	7	6	5	4	3	2	1	0
	DATA[20:0] FIELD																				ADDRESS [2:0] FIELD			
R1	RF _PD	RF _P	LMX2430/33 RF_B[14:0]												LMX2430/33 RF_A[3:0]			0	0	1				
R1	RF _PD	RF _P	LMX2434 RF_B[13:0]												LMX2434 RF_A[4:0]			0	0	1				

LMX243x RF Synthesizer Swallow Counter

RF_A[3:0] - LMX2430/33 RF Synthesizer Swallow Counter (A Counter) (R1[6:3])

The RF_A control word is used to setup the RF synthesizer's A counter. For both the LMX2430 and LMX2433, the A counter is a 4-bit swallow counter used in the programmable feedback divider. The RF_A control word can be programmed to values ranging from 0 to 15.

Divide Ratio	LMX2430/33 RF_A[3:0]			
	3	2	1	0
0	0	0	0	0
1	0	0	0	1
•	•	•	•	•
15	1	1	1	1

RF_A[4:0] - LMX2434 RF Synthesizer Swallow Counter (A Counter) (R1[7:3])

The LMX2434 A counter is a 5-bit swallow counter used in the programmable feedback divider. The RF_A control word can be programmed to values ranging from 0 to 31.

Divide Ratio	LMX2434 RF_A[4:0]				
	4	3	2	1	0
0	0	0	0	0	0
1	0	0	0	0	1
•	•	•	•	•	•
31	1	1	1	1	1

LMX243x RF Synthesizer Programmable Binary Counter
RF_B[14:0] - LMX2430/33 RF Synthesizer Programmable Binary Counter (B Counter) (R1[21:7])

The RF_B control word is used to setup the RF synthesizer's B counter. For both the LMX2430 and LMX2433, the B counter is a 15-bit programmable binary counter used in the programmable feedback divider. The RF_B control word can be programmed to values ranging from 3 to 32767. Divide ratios less than 3 are prohibited.

Divide Ratio	LMX2430/33 RF_B[14:0]														
	14	13	12	11	10	9	8	7	6	5	4	3	2	1	0
3	0	0	0	0	0	0	0	0	0	0	0	0	0	1	1
4	0	0	0	0	0	0	0	0	0	0	0	0	1	0	0
•	•	•	•	•	•	•	•	•	•	•	•	•	•	•	•
32767	1	1	1	1	1	1	1	1	1	1	1	1	1	1	1

RF_B[13:0] - LMX2434 RF Synthesizer Programmable Binary Counter (B Counter) (R1[21:8])

The LMX2434 B counter is a 14-bit programmable binary counter used in the programmable feedback divider. The RF_B control word can be programmed to values ranging from 3 to 16383. Divide ratios less than 3 are prohibited.

Divide Ratio	LMX2434 RF_B[13:0]													
	13	12	11	10	9	8	7	6	5	4	3	2	1	0
3	0	0	0	0	0	0	0	0	0	0	0	0	1	1
4	0	0	0	0	0	0	0	0	0	0	0	1	0	0
•	•	•	•	•	•	•	•	•	•	•	•	•	•	•
16383	1	1	1	1	1	1	1	1	1	1	1	1	1	1

LMX243x RF Synthesizer Prescaler Select
RF_P - LMX2430/33 RF Synthesizer Prescaler Select (R1[22])

Both the LMX2430 and LMX2433 RF synthesizers utilize a selectable dual modulus prescaler. An 8/9 or a 16/17 prescale ratio can be selected.

Control Bit	Register Location	Description	Function	
			0	1
RF_P	R1[22]	LMX2430/33 RF Prescaler Select	8/9 Prescaler Selected	16/17 Prescaler Selected

RF_P - LMX2434 RF Synthesizer Prescaler Select (R1[22])

The LMX2434 RF synthesizer utilizes a selectable dual modulus prescaler. A 16/17 or a 32/33 prescale ratio can be selected.

Control Bit	Register Location	Description	Function	
			0	1
RF_P	R1[22]	LMX2434 RF Prescaler Select	16/17 Prescaler Selected	32/33 Prescaler Selected

RF_PD - RF Synthesizer Powerdown (R1[23])

The RF_PD bit is used to switch the RF PLL between a powered up and powered down mode.

Furthermore, the RF_PD bit operates in conjunction with the RF_CPT bit to set a synchronous or an asynchronous powerdown mode. Refer to [RF_CPT - RF Synthesizer Charge Pump TRI-STATE \(R0\[20\]\)](#) for more details on how to program the RF_CPT bit.

Control Bit	Register Location	Description	Function	
			0	1
RF_PD	R1[23]	RF Powerdown	RF PLL Active	RF PLL Powerdown

R2 REGISTER

The R2 Register contains the RF_TOC control word. The RF_TOC is used to setup the RF synthesizer's Fastlock circuitry. The RF_TOC is a 12-bit binary counter programmable from 0 to 4095.

Reg	23	22	21	20	19	18	17	16	15	14	13	12	11	10	9	8	7	6	5	4	3	2	1	0
	DATA[20:0] FIELD																				ADDRESS [2:0] FIELD			
R2	0	0	0	0	0	0	0	0	0	RF_TOC[11:0]											0	1	0	

RF_TOC[0:11] - RF Synthesizer Timeout Counter (R2[14:3])

The FLoutRF pin can be configured as a general purpose CMOS TRI-STATE output or as a Fastlock output by programming the RF_TOC appropriately. When the RF_TOC is programmed from 0 to 3, Automatic Fastlock is disabled, and the FLoutRF pin is either configured as a general purpose CMOS TRI-STATE output or Manual Fastlock is enabled. When the RF_TOC is programmed to 0, the FLoutRF pin will be in TRI-STATE (high impedance) mode. The charge pump current is then the value specified by RF_CPG (R0[19]). When the RF_TOC is programmed to 1, the FLoutRF pin is pulled to a LOW state. The charge pump current is then set to a HIGH gain state (RF_CPG bit = 1). This condition is known as the Manual Fastlock. When the RF_TOC is programmed to 2, the FLoutRF pin will again be pulled to a LOW state, but this time the charge pump current is the value specified by RF_CPG (R0[19]). When the RF_TOC is programmed to 3, the FLoutRF pin is pulled to a HIGH state. Again, the charge pump current is the value specified by RF_CPG (R0[19]). When the RF_TOC is programmed from 4 to 4095, Fastlock is enabled and the FLoutRF pin is pulled to a LOW state. Fastlock will time-out after the specified number of PFD events. At this time, the FLoutRF pin will switch to TRI-STATE (high impedance) mode. The value programmed into RF_TOC represents the number of PFD events that the RF synthesizer will spend in the Fastlock state. Note that any write to the RF_TOC requires a PFD event on the RF synthesizer to latch the contents. This means that writes to the RF_TOC take effect synchronously with the next PFD event.

RF_TOC[11:0]	FastLock Mode	Fastlock Period [PFD Events]	FLoutRF Pin Functionality/ State	I _{CPoutRF} Magnitude
0	Disabled	N/A	General Purpose. High Impedance State	I _{CPoutRF} magnitude controlled by R0[19]
1	Enabled Manual Fastlock	N/A	General Purpose. Logic LOW State	I _{CPoutRF} = 4 mA
2	Disabled	N/A	General Purpose. Logic LOW State	I _{CPoutRF} magnitude controlled by R0[19]
3	Disabled	N/A	General Purpose. Logic HIGH State	I _{CPoutRF} magnitude controlled by R0[19]
4	Enabled Automatic Fastlock	4	FastLock. Logic LOW State. Switches to High Impedance after 4 PFD events	I _{CPoutRF} = 4 mA Switches to 1 mA after 4 PFD events
...
4095	Enabled Automatic Fastlock	4095	FastLock. Logic LOW State. Switches to High Impedance after 4095 PFD events	I _{CPoutRF} = 4 mA Switches to 1 mA after 4095 PFD events

R3 REGISTER

The R3 register contains the IF_R, IF_CPP, IF_CPG, IF_CPT, and IF_RST control words, in addition to two of the four bits that compose the MUX control word. The detailed descriptions and programming information for each control word is discussed in the following sections.

Reg	23	22	21	20	19	18	17	16	15	14	13	12	11	10	9	8	7	6	5	4	3	2	1	0
	DATA[20:0] FIELD																					ADDRESS [2:0] FIELD		
R3	MUX[1:0]		IF_RST	IF_CPT	IF_CPG	IF_CPP	IF_R[14:0]															0	1	1

IF_R[14:0] - IF Synthesizer Programmable Reference Divider (R Counter) (R3[17:3])

The IF reference divider (IF_R) can be programmed to support divide ratios from 3 to 32767. Divide ratios less than 3 are prohibited.

Divide Ratio	IF_R[14:0]															
	14	13	12	11	10	9	8	7	6	5	4	3	2	1	0	
3	0	0	0	0	0	0	0	0	0	0	0	0	0	1	1	
4	0	0	0	0	0	0	0	0	0	0	0	0	1	0	0	
•	•	•	•	•	•	•	•	•	•	•	•	•	•	•	•	
32767	1	1	1	1	1	1	1	1	1	1	1	1	1	1	1	

IF_CPP - IF Synthesizer Phase Detector Polarity (R3[18])

The IF_CPP bit is used to control the IF synthesizer's phase/ frequency detector polarity based on the VCO tuning characteristics.

Control Bit	Register Location	Description	Function	
			0	1
IF_CPP	R3[18]	IF Phase/ Frequency Detector Polarity	IF VCO Negative Tuning Characteristics	IF VCO Positive Tuning Characteristics

Figure 37. IF VCO Characteristics

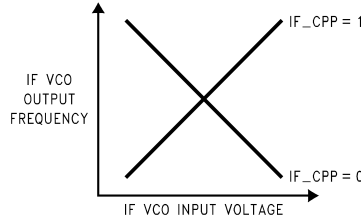

IF_CPG - IF Synthesizer Charge Pump Current Gain (R3[19])

The IF_CPG bit controls the IF synthesizer's charge pump gain. Two gain levels are available.

Control Bit	Register Location	Description	Function	
			0	1
IF_CPG	R3[19]	IF Charge Pump Current Gain	LOW 1 mA	HIGH 4 mA

IF_CPT - IF Synthesizer Charge Pump TRI-STATE (R3[20])

The IF_CPT bit allows the charge pump to be switched between a normal operating mode and a high impedance output state. This happens asynchronously with the change in the IF_CPT bit.

Furthermore, the IF_CPT bit operates in conjunction with the IF_PD bit to set a synchronous or an asynchronous powerdown mode. Refer to [IF_PD - IF Synthesizer Powerdown \(R4\[23\]\)](#) for more details on how to program the IF_PD bit.

Control Bit	Register Location	Description	Function	
			0	1
IF_CPT	R3[20]	IF Charge Pump TRI-STATE	IF Charge Pump Normal Operation	IF Charge Pump Output in High Impedance State

IF_RST - IF Synthesizer Counter Reset (R3[21])

The IF_RST bit resets of the IF_A, IF_B and IF_R counters. After removing the reset, the IF_A and IF_B counters resume counting in close alignment with the IF_R counter. The maximum error is one prescaler cycle.

Control Bit	Register Location	Description	Function	
			0	1
IF_RST	R3[21]	IF Counter Reset	IF_A, IF_B and IF_R Normal Operation	IF_A, IF_B and IF_R Reset

R4 REGISTER

The R4 register contains the IF_A, IF_B, IF_P, and IF_PD control words. The IF_A and IF_B control words are used to setup the programmable feedback divider. The detailed descriptions and programming information for each control word is discussed in the following sections. R4[21] is always set to 0.

Reg	23	22	21	20	19	18	17	16	15	14	13	12	11	10	9	8	7	6	5	4	3	2	1	0		
	DATA[20:0] FIELD																					ADDRESS [2:0] FIELD				
R4	IF_PD	IF_P	0	IF_B[13:0]																	IF_A[3:0]			1	0	0

IF_A[3:0] - IF Synthesizer Swallow Counter (A Counter) (R4[6:3])

The IF_A control word is used to setup the IF synthesizer's A counter. The A counter is a 4-bit swallow counter used in the programmable feedback divider. The IF_A control word can be programmed to values ranging from 0 to 15.

Divide Ratio	IF_A[3:0]			
	3	2	1	0
0	0	0	0	0
1	0	0	0	1
•	•	•	•	•
15	1	1	1	1

IF_B[13:0] - IF Synthesizer Programmable Binary Counter (B Counter) (R4[20:7])

The IF_B control word is used to setup the IF synthesizer's B counter. The B counter is a 14-bit programmable binary counter used in the programmable feedback divider. The IF_B control word can be programmed to values ranging from 3 to 16383. Divide ratios less than 3 are prohibited.

Divide Ratio	IF_B[13:0]													
	13	12	11	10	9	8	7	6	5	4	3	2	1	0
3	0	0	0	0	0	0	0	0	0	0	0	0	1	1
4	0	0	0	0	0	0	0	0	0	0	0	1	0	0
•	•	•	•	•	•	•	•	•	•	•	•	•	•	•
16383	1	1	1	1	1	1	1	1	1	1	1	1	1	1

IF_P - IF Synthesizer Prescaler Select (R4[22])

The LMX243x IF synthesizer utilizes a selectable dual modulus prescaler. An 8/9 or a 16/17 prescale ratio can be selected.

Control Bit	Register Location	Description	Function	
			0	1
IF_P	R4[22]	IF Prescaler Select	8/9 Prescaler Selected	16/17 Prescaler Selected

IF_PD - IF Synthesizer Powerdown (R4[23])

The IF_PD bit is used to switch the IF PLL between a powered up and powered down mode.

Furthermore, the IF_PD bit operates in conjunction with the IF_CPT bit to set a synchronous or an asynchronous powerdown mode. Refer to [IF_CPT - IF Synthesizer Charge Pump TRI-STATE \(R3\[20\]\)](#) for more details on how to program the IF_CPT bit.

Control Bit	Register Location	Description	Function	
			0	1
IF_PD	R4[23]	IF Powerdown	IF PLL Active	IF PLL Powerdown

R5 REGISTER

The R5 Register contains the IF_TOC control word. The IF_TOC is used to setup the IF synthesizer's Fastlock circuitry. The IF_TOC is a 12-bit binary counter programmable from 0 to 4095.

Reg	23	22	21	20	19	18	17	16	15	14	13	12	11	10	9	8	7	6	5	4	3	2	1	0
	DATA[20:0] FIELD																					ADDRESS [2:0] FIELD		
R5	0	0	0	0	0	0	0	0	0	0	IF_TOC[11:0]											1	0	1

IF_TOC[0:11] - IF Synthesizer Timeout Counter (R5[14:3])

The OSCout/ FLoutIF pin can be configured as a general purpose CMOS TRI-STATE output or as a Fastlock output by programming the IF_TOC appropriately. When the IF_TOC is programmed from 0 to 3, Automatic Fastlock is disabled, and the OSCout/ FLoutIF pin is configured as a general purpose CMOS TRI-STATE output or Manual Fastlock is enabled. When the IF_TOC is programmed to 0, the OSCout/ FLoutIF pin will be in TRI-STATE (high impedance) mode. The charge pump current is then the value specified by IF_CPG (R3[19]). When the IF_TOC is programmed to 1, the OSCout/ FLoutIF pin is pulled to a LOW state. The charge pump current is then set to a HIGH gain state (IF_CPG bit = 1). This condition is known as the Manual Fastlock. When the IF_TOC is programmed to 2, the OSCout/ FLoutIF pin will again be pulled to a LOW state, but this time the charge pump current is the value specified by IF_CPG (R3[19]). When the IF_TOC is programmed to 3, the OSCout/ FLoutIF pin is pulled to a HIGH state. Again, the charge pump current is the value specified by IF_CPG (R3[19]). When the IF_TOC is programmed from 4 to 4095, Fastlock is enabled and the OSCout/ FLoutIF pin is pulled to a LOW state. Fastlock will time-out after the specified number of PFD events. At this time, the OSCout/ FLoutIF pin will switch to TRI-STATE (high impedance) mode. The value programmed into IF_TOC represents the number of PFD events that the IF synthesizer will spend in the Fastlock state. Note that any write to the IF_TOC requires a PFD event on the IF synthesizer to latch the contents. This means that writes to the IF_TOC take effect synchronously with the next PFD event.

IF_TOC[11:0]	FastLock Mode	Fastlock Period [PFD Events]	OSCout/ FLoutIF Pin Functionality/ State	I _{CPoutIF} Magnitude
0	Disabled	N/A	General Purpose. High Impedance State	I _{CPoutIF} magnitude controlled by R3[19]
1	Enabled Manual Fastlock	N/A	General Purpose. Logic LOW State	I _{CPoutIF} = 4 mA
2	Disabled	N/A	General Purpose. Logic LOW State	I _{CPoutIF} magnitude controlled by R3[19]
3	Disabled	N/A	General Purpose. Logic HIGH State	I _{CPoutIF} magnitude controlled by R3[19]
4	Enabled Automatic Fastlock	4	FastLock. Logic LOW State. Switches to High Impedance after 4 PFD events	I _{CPoutIF} = 4 mA Switches to 1 mA after 4 PFD events
...
4095	Enabled Automatic Fastlock	4095	FastLock. Logic LOW State. Switches to High Impedance after 4095 PFD events	I _{CPoutIF} = 4 mA Switches to 1 mA after 4095 PFD events

MUX[3:0] - MULTIFUNCTION OUTPUT SELECT (R3[23:22]:R0[23:22])

The MUX control word is used to determine which signal is routed to the Ftest/LD pin.

MUX[3:0]				MUX Output State
0	0	0	0	High Impedance (TRI-STATE) State Output
0	0	0	1	Logic HIGH State Output
0	0	1	0	Logic LOW State Output
0	0	1	1	RF PLL and IF PLL Digital Lock Detect. Open Drain Output
0	1	0	0	RF PLL Digital Lock Detect. Open Drain Output
0	1	0	1	IF PLL Digital Lock Detect. Open Drain Output
0	1	1	0	RF PLL and IF PLL Analog Lock Detect. Open Drain Output
0	1	1	1	RF PLL Analog Lock Detect. Open Drain Output
1	0	0	0	IF PLL Analog Lock Detect. Open Drain Output
1	0	0	1	RF PLL and IF PLL Analog Lock Detect. Push-Pull Output
1	0	1	0	RF PLL Analog Lock Detect. Push-Pull Output
1	0	1	1	IF PLL Analog Lock Detect. Push-Pull Output
1	1	0	0	IF_R/ 2 Frequency
1	1	0	1	IF_N/ 2 Frequency
1	1	1	0	RF_R/ 2 Frequency
1	1	1	1	RF_N/ 2 Frequency

Notes:

1. $RF_N = (RF_B * RF_P) + RF_A$
2. $IF_N = (IF_B * IF_P) + IF_A$

REVISION HISTORY

Changes from Revision B (March 2013) to Revision C	Page
• Changed layout of National Data Sheet to TI format	39

PACKAGING INFORMATION

Orderable Device	Status (1)	Package Type	Package Drawing	Pins	Package Qty	Eco Plan (2)	Lead/Ball Finish	MSL Peak Temp (3)	Op Temp (°C)	Top-Side Markings (4)	Samples
LMX2430SLEX/NOPB	ACTIVE	ULGA	NPE	20	2500	Green (RoHS & no Sb/Br)	NIAU	Level-1-260C-UNLIM	-40 to 85	X2430 SLE	Samples
LMX2430TM/NOPB	ACTIVE	TSSOP	PW	20	73	Green (RoHS & no Sb/Br)	CU SN	Level-1-260C-UNLIM	-40 to 85	LMX2430 TM>D	Samples
LMX2430TMX/NOPB	ACTIVE	TSSOP	PW	20	2500	Green (RoHS & no Sb/Br)	CU SN	Level-1-260C-UNLIM	-40 to 85	LMX2430 TM>D	Samples
LMX2433SLEX/NOPB	ACTIVE	ULGA	NPE	20	2500	Green (RoHS & no Sb/Br)	NIAU	Level-1-260C-UNLIM	-40 to 85	X2433 SLE	Samples
LMX2433TM/NOPB	ACTIVE	TSSOP	PW	20	73	Green (RoHS & no Sb/Br)	CU SN	Level-1-260C-UNLIM	-40 to 85	LMX2433 TM>D	Samples
LMX2433TMX	ACTIVE	TSSOP	PW	20	2500	TBD	Call TI	Call TI	-40 to 85		Samples
LMX2433TMX/NOPB	ACTIVE	TSSOP	PW	20	2500	Green (RoHS & no Sb/Br)	CU SN	Level-1-260C-UNLIM	-40 to 85	LMX2433 TM>D	Samples
LMX2434SLEX/NOPB	ACTIVE	ULGA	NPE	20	2500	Green (RoHS & no Sb/Br)	NIAU	Level-1-260C-UNLIM	-40 to 85	X2434 SLE	Samples
LMX2434TM/NOPB	ACTIVE	TSSOP	PW	20	73	Green (RoHS & no Sb/Br)	CU SN	Level-1-260C-UNLIM	-40 to 85	LMX2434 TM>D	Samples
LMX2434TMX	ACTIVE	TSSOP	PW	20	2500	TBD	Call TI	Call TI	-40 to 85		Samples
LMX2434TMX/NOPB	ACTIVE	TSSOP	PW	20	2500	Green (RoHS & no Sb/Br)	CU SN	Level-1-260C-UNLIM	-40 to 85	LMX2434 TM>D	Samples

(1) The marketing status values are defined as follows:

ACTIVE: Product device recommended for new designs.

LIFEBUY: TI has announced that the device will be discontinued, and a lifetime-buy period is in effect.

NRND: Not recommended for new designs. Device is in production to support existing customers, but TI does not recommend using this part in a new design.

PREVIEW: Device has been announced but is not in production. Samples may or may not be available.

OBSOLETE: TI has discontinued the production of the device.

(2) Eco Plan - The planned eco-friendly classification: Pb-Free (RoHS), Pb-Free (RoHS Exempt), or Green (RoHS & no Sb/Br) - please check <http://www.ti.com/productcontent> for the latest availability information and additional product content details.

TBD: The Pb-Free/Green conversion plan has not been defined.

Pb-Free (RoHS): TI's terms "Lead-Free" or "Pb-Free" mean semiconductor products that are compatible with the current RoHS requirements for all 6 substances, including the requirement that lead not exceed 0.1% by weight in homogeneous materials. Where designed to be soldered at high temperatures, TI Pb-Free products are suitable for use in specified lead-free processes.

Pb-Free (RoHS Exempt): This component has a RoHS exemption for either 1) lead-based flip-chip solder bumps used between the die and package, or 2) lead-based die adhesive used between the die and leadframe. The component is otherwise considered Pb-Free (RoHS compatible) as defined above.

Green (RoHS & no Sb/Br): TI defines "Green" to mean Pb-Free (RoHS compatible), and free of Bromine (Br) and Antimony (Sb) based flame retardants (Br or Sb do not exceed 0.1% by weight in homogeneous material)

(3) MSL, Peak Temp. -- The Moisture Sensitivity Level rating according to the JEDEC industry standard classifications, and peak solder temperature.

(4) Multiple Top-Side Markings will be inside parentheses. Only one Top-Side Marking contained in parentheses and separated by a "~" will appear on a device. If a line is indented then it is a continuation of the previous line and the two combined represent the entire Top-Side Marking for that device.

Important Information and Disclaimer: The information provided on this page represents TI's knowledge and belief as of the date that it is provided. TI bases its knowledge and belief on information provided by third parties, and makes no representation or warranty as to the accuracy of such information. Efforts are underway to better integrate information from third parties. TI has taken and continues to take reasonable steps to provide representative and accurate information but may not have conducted destructive testing or chemical analysis on incoming materials and chemicals. TI and TI suppliers consider certain information to be proprietary, and thus CAS numbers and other limited information may not be available for release.

In no event shall TI's liability arising out of such information exceed the total purchase price of the TI part(s) at issue in this document sold by TI to Customer on an annual basis.

TAPE AND REEL INFORMATION



QUADRANT ASSIGNMENTS FOR PIN 1 ORIENTATION IN TAPE



*All dimensions are nominal

Device	Package Type	Package Drawing	Pins	SPQ	Reel Diameter (mm)	Reel Width W1 (mm)	A0 (mm)	B0 (mm)	K0 (mm)	P1 (mm)	W (mm)	Pin1 Quadrant
LMX2430SLEX/NOPB	ULGA	NPE	20	2500	330.0	12.4	3.8	3.8	1.3	8.0	12.0	Q1
LMX2430TMX/NOPB	TSSOP	PW	20	2500	330.0	16.4	6.95	7.1	1.6	8.0	16.0	Q1
LMX2433SLEX/NOPB	ULGA	NPE	20	2500	330.0	12.4	3.8	3.8	1.3	8.0	12.0	Q1
LMX2433TMX/NOPB	TSSOP	PW	20	2500	330.0	16.4	6.95	7.1	1.6	8.0	16.0	Q1
LMX2434SLEX/NOPB	ULGA	NPE	20	2500	330.0	12.4	3.8	3.8	1.3	8.0	12.0	Q1
LMX2434TMX/NOPB	TSSOP	PW	20	2500	330.0	16.4	6.95	7.1	1.6	8.0	16.0	Q1

TAPE AND REEL BOX DIMENSIONS

*All dimensions are nominal

Device	Package Type	Package Drawing	Pins	SPQ	Length (mm)	Width (mm)	Height (mm)
LMX2430SLEX/NOPB	ULGA	NPE	20	2500	367.0	367.0	35.0
LMX2430TMX/NOPB	TSSOP	PW	20	2500	367.0	367.0	35.0
LMX2433SLEX/NOPB	ULGA	NPE	20	2500	367.0	367.0	35.0
LMX2433TMX/NOPB	TSSOP	PW	20	2500	367.0	367.0	35.0
LMX2434SLEX/NOPB	ULGA	NPE	20	2500	367.0	367.0	35.0
LMX2434TMX/NOPB	TSSOP	PW	20	2500	367.0	367.0	35.0

PW (R-PDSO-G20)

PLASTIC SMALL OUTLINE



4040064-5/G 02/11

- NOTES:
- A. All linear dimensions are in millimeters. Dimensioning and tolerancing per ASME Y14.5M-1994.
 - B. This drawing is subject to change without notice.
 - C. Body length does not include mold flash, protrusions, or gate burrs. Mold flash, protrusions, or gate burrs shall not exceed 0,15 each side.
 - D. Body width does not include interlead flash. Interlead flash shall not exceed 0,25 each side.
 - E. Falls within JEDEC MO-153

NPE0020A

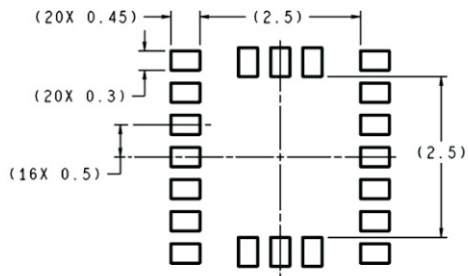

RECOMMENDED LAND PATTERN
1:1 RATIO WITH PACKAGE SOLDER PADS

DIMENSIONS ARE IN MILLIMETERS

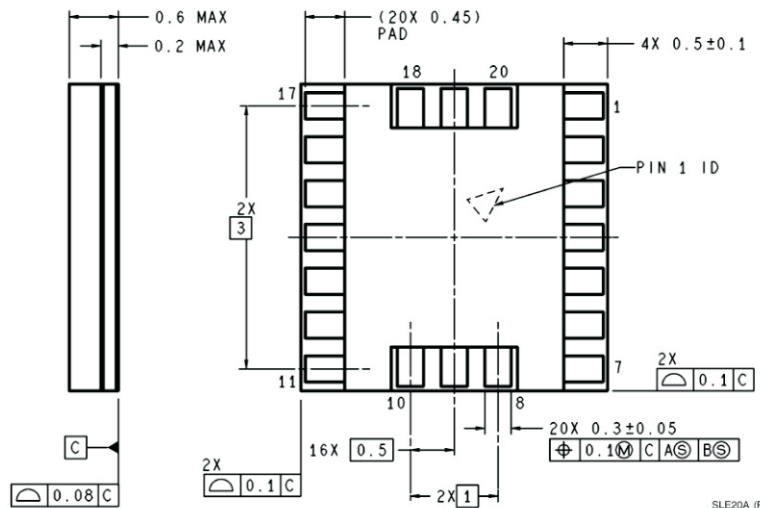
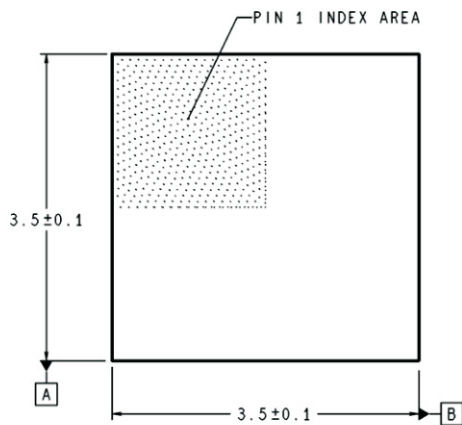

SLE20A (Rev A)

IMPORTANT NOTICE

Texas Instruments Incorporated and its subsidiaries (TI) reserve the right to make corrections, enhancements, improvements and other changes to its semiconductor products and services per JESD46, latest issue, and to discontinue any product or service per JESD48, latest issue. Buyers should obtain the latest relevant information before placing orders and should verify that such information is current and complete. All semiconductor products (also referred to herein as "components") are sold subject to TI's terms and conditions of sale supplied at the time of order acknowledgment.

TI warrants performance of its components to the specifications applicable at the time of sale, in accordance with the warranty in TI's terms and conditions of sale of semiconductor products. Testing and other quality control techniques are used to the extent TI deems necessary to support this warranty. Except where mandated by applicable law, testing of all parameters of each component is not necessarily performed.

TI assumes no liability for applications assistance or the design of Buyers' products. Buyers are responsible for their products and applications using TI components. To minimize the risks associated with Buyers' products and applications, Buyers should provide adequate design and operating safeguards.

TI does not warrant or represent that any license, either express or implied, is granted under any patent right, copyright, mask work right, or other intellectual property right relating to any combination, machine, or process in which TI components or services are used. Information published by TI regarding third-party products or services does not constitute a license to use such products or services or a warranty or endorsement thereof. Use of such information may require a license from a third party under the patents or other intellectual property of the third party, or a license from TI under the patents or other intellectual property of TI.

Reproduction of significant portions of TI information in TI data books or data sheets is permissible only if reproduction is without alteration and is accompanied by all associated warranties, conditions, limitations, and notices. TI is not responsible or liable for such altered documentation. Information of third parties may be subject to additional restrictions.

Resale of TI components or services with statements different from or beyond the parameters stated by TI for that component or service voids all express and any implied warranties for the associated TI component or service and is an unfair and deceptive business practice. TI is not responsible or liable for any such statements.

Buyer acknowledges and agrees that it is solely responsible for compliance with all legal, regulatory and safety-related requirements concerning its products, and any use of TI components in its applications, notwithstanding any applications-related information or support that may be provided by TI. Buyer represents and agrees that it has all the necessary expertise to create and implement safeguards which anticipate dangerous consequences of failures, monitor failures and their consequences, lessen the likelihood of failures that might cause harm and take appropriate remedial actions. Buyer will fully indemnify TI and its representatives against any damages arising out of the use of any TI components in safety-critical applications.

In some cases, TI components may be promoted specifically to facilitate safety-related applications. With such components, TI's goal is to help enable customers to design and create their own end-product solutions that meet applicable functional safety standards and requirements. Nonetheless, such components are subject to these terms.

No TI components are authorized for use in FDA Class III (or similar life-critical medical equipment) unless authorized officers of the parties have executed a special agreement specifically governing such use.

Only those TI components which TI has specifically designated as military grade or "enhanced plastic" are designed and intended for use in military/aerospace applications or environments. Buyer acknowledges and agrees that any military or aerospace use of TI components which have **not** been so designated is solely at the Buyer's risk, and that Buyer is solely responsible for compliance with all legal and regulatory requirements in connection with such use.

TI has specifically designated certain components as meeting ISO/TS16949 requirements, mainly for automotive use. In any case of use of non-designated products, TI will not be responsible for any failure to meet ISO/TS16949.

Products

Audio	www.ti.com/audio
Amplifiers	amplifier.ti.com
Data Converters	dataconverter.ti.com
DLP® Products	www.dlp.com
DSP	dsp.ti.com
Clocks and Timers	www.ti.com/clocks
Interface	interface.ti.com
Logic	logic.ti.com
Power Mgmt	power.ti.com
Microcontrollers	microcontroller.ti.com
RFID	www.ti-rfid.com
OMAP Applications Processors	www.ti.com/omap
Wireless Connectivity	www.ti.com/wirelessconnectivity

Applications

Automotive and Transportation	www.ti.com/automotive
Communications and Telecom	www.ti.com/communications
Computers and Peripherals	www.ti.com/computers
Consumer Electronics	www.ti.com/consumer-apps
Energy and Lighting	www.ti.com/energy
Industrial	www.ti.com/industrial
Medical	www.ti.com/medical
Security	www.ti.com/security
Space, Avionics and Defense	www.ti.com/space-avionics-defense
Video and Imaging	www.ti.com/video

TI E2E Community

e2e.ti.com

Mouser Electronics

Authorized Distributor

Click to View Pricing, Inventory, Delivery & Lifecycle Information:

Texas Instruments:

[LMX2430SLEX/NOPB](#) [LMX2430TM/NOPB](#) [LMX2430TMX/NOPB](#) [LMX2433SLEX/NOPB](#) [LMX2433TM/NOPB](#)
[LMX2433TMX](#) [LMX2433TMX/NOPB](#) [LMX2434SLEX/NOPB](#) [LMX2434TM/NOPB](#) [LMX2434TMX](#) [LMX2434TMX/NOPB](#)