

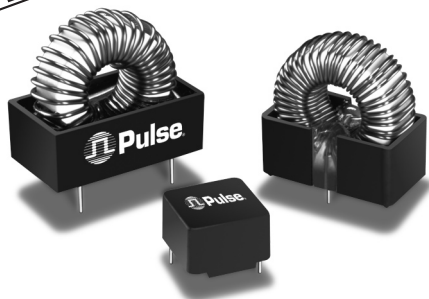



INDUCTORS DESIGNED FOR NATIONAL'S 50 kHz SIMPLE SWITCHER™



-  Designed for use with National's device numbers LM2574/LM2575/LM2576
-  Base material meets flammability requirements of UL 94V-0
-  Performance verified by National Semiconductor

Electrical Specifications @ 25°C— Operating Temperature -40° to +130° C

Part Identification		Reference Operating Values ¹			Design Control Values			
Part Number	Inductor Code	Inductance Typical (μH)	I _{dc} (Amps)	E _{Top} (V-μSec)	Inductance No DC ² (μH ± 20%)	DCR (Ω MAX)	Package Style	Lead Diameter
PE-53112	L47	47	3.0	90	38	0.05	KM-2.0	.025
PE-92114K	L68	36	5.0	90	56	0.02	KM-4.0	.040
PE-92108K	L100	100	3.0	90	91	0.04	KM-4.0	.032
PE-53113	L150	150	2.0	90	130	0.10	KM-4.0	.025
PE-52626	L220	220	1.4	90	230	0.38	Low Profile	.025 SQ.
PE-53145	L220	220	1.4	90	176	0.14	KM-3.0	.020
PE-52627	L330	330	0.9	90	302	0.74	Low Profile	.025 SQ.
PE-53146	L330	330	0.9	90	267	0.18	KM-3.0	.020
PE-53114	L470	470	0.64	90	426	0.16	KM-4.0	.025
PE-52629	L680	680	.85	90	657	1.25	Low Profile	.025 SQ.
PE-53115	H150	150	3.0	200	136	0.10	KM-4.0	.025
PE-53116	H220	220	3.0	200	167	0.07	KM-5.0	.032
PE-53117	H330	330	3.0	200	292	0.15	KM-5.0	.025
PE-53118	H470	470	2.0	200	369	0.17	KM-5.0	.025
PE-53119	H680	680	1.3	200	562	0.20	KM-5.0	.025
PE-53120	H1000	1000	0.95	200	762	0.24	KM-5.0	.025
PE-53121	H1500	1500	0.62	200	1150	1.00	Case	.032
PE-53122	H220	2200	0.42	200	1886	1.80	Case	.032

NOTES:

1. Typical inductance occurs at the I_{DC} and E_{TOP} values shown.
2. The control value of inductance is measured at B_{OP} equal to or less than 10 gauss without DC current.
3. Inductance decreases with higher values of DC current and increases with lower values of DC current.
4. Inductance increases with increase in B_{OP} or E_{TOP}.
5. SIMPLE SWITCHER™ is a trademark of National Semiconductor Corporation.
6. RoHS compliant parts are available. Order RoHS compliant parts by adding the suffix "NL" to the part number (i.e. PE-53112 becomes PE-53112NL).

INDUCTORS DESIGNED FOR NATIONAL'S 50 kHz SIMPLE SWITCHER™



Mechanicals

Low Profile Series

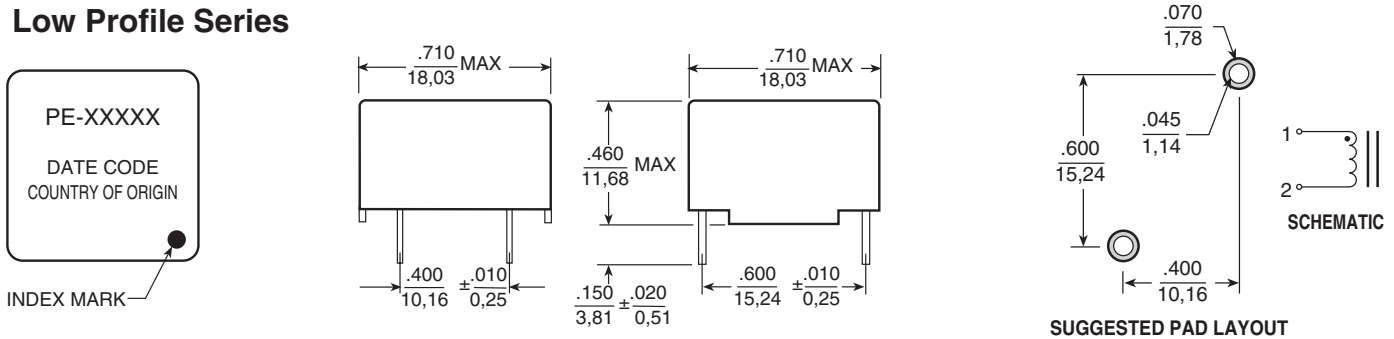

Case Series

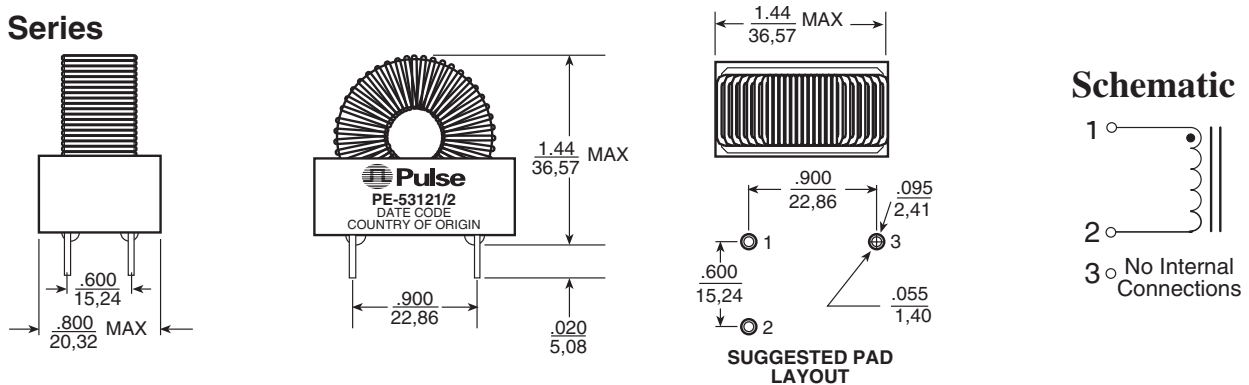

KlipMount Series

PKG	A	B	C	D	E
KM-2.0	.450 11,43	.650 16,51	.700 17,78	.325 8,26	.150 3,81
KM-3.0	.450 11,43	.830 21,08	.950 24,13	.415 10,54	.150 3,81
KM-4.0	.610 15,50	.970 24,64	1.10 27,94	.475 12,07	.225 5,72
KM-5.0	.700 17,78	1.30 33,02	1.40 35,56	.625 15,88	.250 6,35

Dimensions: $\frac{\text{Inches}}{\text{mm}}$
Unless otherwise specified, all tolerances are $\pm \frac{.010}{0,25}$

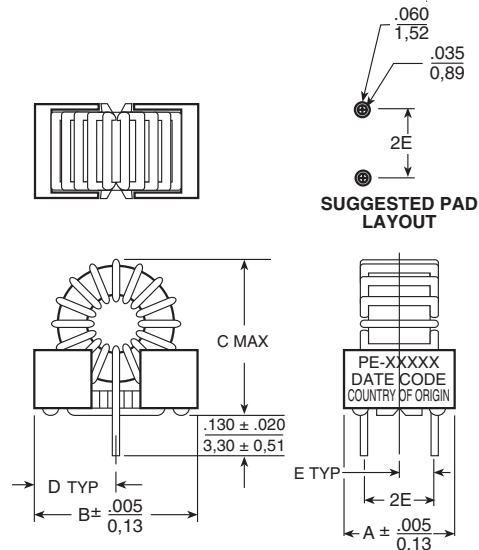

For More Information:

Pulse Worldwide Headquarters
12220 World Trade Dr.
San Diego, CA 92128
U.S.A.
www.pulseeng.com

Pulse European Headquarters
Einsteinstrasse 1
D-71083 Herrenberg
Germany

Pulse China Headquarters
B402, Shenzhen Academy of
Aerospace Technology Bldg.
10th Kejian Rd.
High-Tech Zone
Nanshan District
Shenzhen, PR China 518057

Pulse North China
Room 1503
XinYin Building
No. 888 YiShan Rd.
Shanghai 200233
China

Pulse South Asia
150 Kampong Ampat
#07-01/02
KA Centre
Singapore 368324

Pulse North Asia
No. 26
Kao Ching Rd.
Yang Mei Chen
Taoyuan Hsien
Taiwan, R. O. C.
32667

TEL: 858 674 8100
FAX: 858 674 8262

TEL: 49 7032 7806 0
-FAX: 49 7032 7806 12

TEL: 86 755 33966678
-FAX: 86 755 33966700

TEL: 86 21 32181071
-FAX: 86 21 32181396

TEL: 65 6287 8998
-FAX: 65 6280 0080

TEL: 886 3 4643715
-FAX: 886 3 4641911 -

Performance warranty of products offered on this data sheet is limited to the parameters specified. Data is subject to change without notice. Other brand and product names mentioned herein may be trademarks or registered trademarks of their respective owners. © Copyright, 2008. Pulse Engineering, Inc. All rights reserved.

Mouser Electronics

Authorized Distributor

Click to View Pricing, Inventory, Delivery & Lifecycle Information:

Pulse:

[PE-53121](#) [PE-53114](#) [PE-53119](#) [PE-53117](#) [PE-53146](#) [PE-53122](#) [PE-53115](#) [PE-53116](#) [PE-52626](#) [PE-53113](#) [PE-53145](#)