

Regulations No.	180AA22E	Total Pages	Page
		10	1

The product specifications described in this book are subject to change without notice for the product which is currently under development. At the final stage of your design, purchasing, or use of the product, therefore, ask for the most up-to-date Product Standards in advance to make sure that the latest specifications satisfy your requirements.

# User's Guide for Evaluation Board

Part No.	AN30180AA-EVB
----------	---------------

Automotive & Industrial Systems Company  
Panasonic Corporation

	2013-05-07	
	Revised	

Regulations No.	180AA22E	<b>User's Guide for Evaluation Board</b>	AN30180AA-EVB	
			Total Pages	Page
			10	2

## Contents

### 1 Introduction

1.1	Overview .....	3
1.2	Features .....	3
1.3	Typical Applications .....	3
1.4	Package .....	3
1.5	Type .....	3
1.6	Block Diagram .....	4

### 2 Evaluation Board

2.1	Appearance .....	5
2.2	Switches setup .....	6

### 3 Schematic

4	Bill of Materials .....	8
---	-------------------------	---

### 5 Board Layout

Usage Notes .....		10
-------------------	--	----

	2013-05-07	
	Revised	

Regulations No.	180AA22E	<h1>User's Guide for Evaluation Board</h1>	AN30180AA-EVB	
			Total Pages	Page
			10	3

## 1 Introduction

This user's guide contains background information for the AN30180AA : 1.2A Synchronous DC-DC Step Down Regulator

As well as support documentation for the AN30180AA Evaluation Board (AN30180AA-EVB). Also included are schematic, the test setup ,the bill of materials and the Board Layout for the Evaluation Board.

### 1.1 Overview

AN30180AA is a synchronous DC-DC Step Down Regulator and employs the hysteretic control system.

By this system, when load current charges suddenly, it responds at high speed and minimizes the changes of output voltage.

Since it is possible to use capacitors with small capacitance and it is unnecessary to add external parts for system phase compensation, this IC realizes downsizing of set and reducing in the number of external parts.

### 1.2 Features

- Wide output voltage range : 1.2V to 3.3V
- Input voltage range : 2.5V to 5.5V
- Up to 1200mA Output Current
- Load transient response is fast
- output current limit control of 1.8A to prevent Excessive current flows
- high efficiency over a wide load current area by DCM (discontinuous conductive mode) operation at light loads, CCM (continuous conductive mode) operation in heavy loads those two modes can be automatically switched
- Switching frequency of 2.6MHz during CCM.
- 100% duty operation when input voltage goes down to output voltage.

Table 1. Input Voltage and Output Current Summary

Evaluation Board	Input Voltage Range	Output Current Range
EVB-AN30180AA	VIN = PVIN = AVIN = 2.5V to 5.5V	0A to 1200mA

### 1.3 Typical Applications

- High Current Distributed Power Systems such as power amplifier in cellular phone etc.

### 1.4 Package

- 9 pin Wafer level chip size package (WLCSP Type)  
Size : 1.46 × 1.46 mm ( 0.5 mm pitch)

Top View

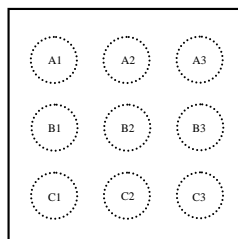

### 1.5 Type

- Bi-CMOS IC

Note: The parameters above is subject to change for improvement without notice.

	2013-05-07	
	Revised	

Regulations No.	180AA22E	User's Guide for Evaluation Board		AN30180AA-EVB	
				Total Pages	Page
				10	4

## 1.6 Block Diagram

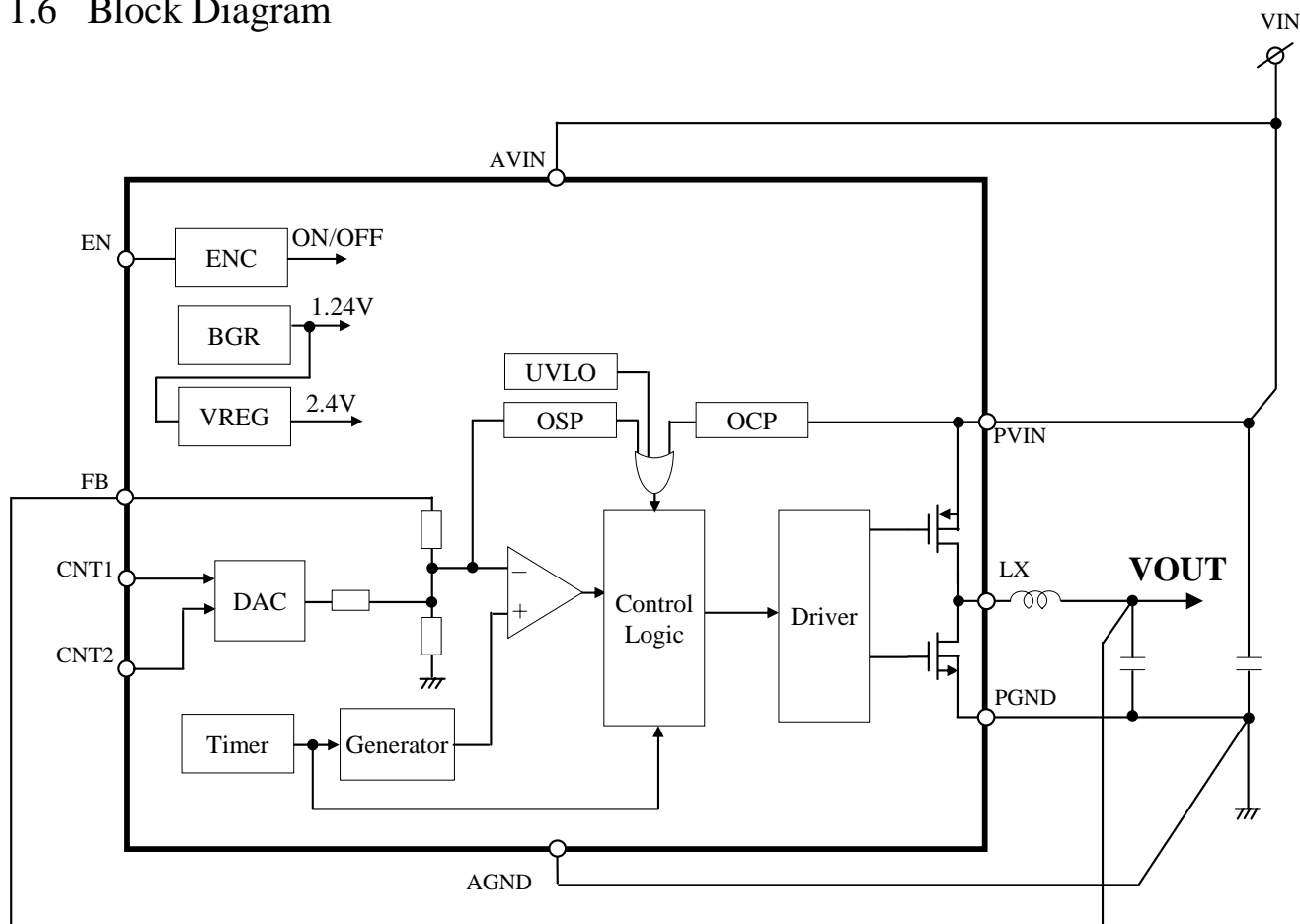

Figure 1. Block Diagram

Note: The parameters above is subject to change for improvement without notice.

	2013-05-07	
	Revised	

Regulations No.	180AA22E	User's Guide for Evaluation Board		AN30180AA-EVB	
				Total Pages	Page
				10	5

2 Evaluation Board

2.1 Appearance

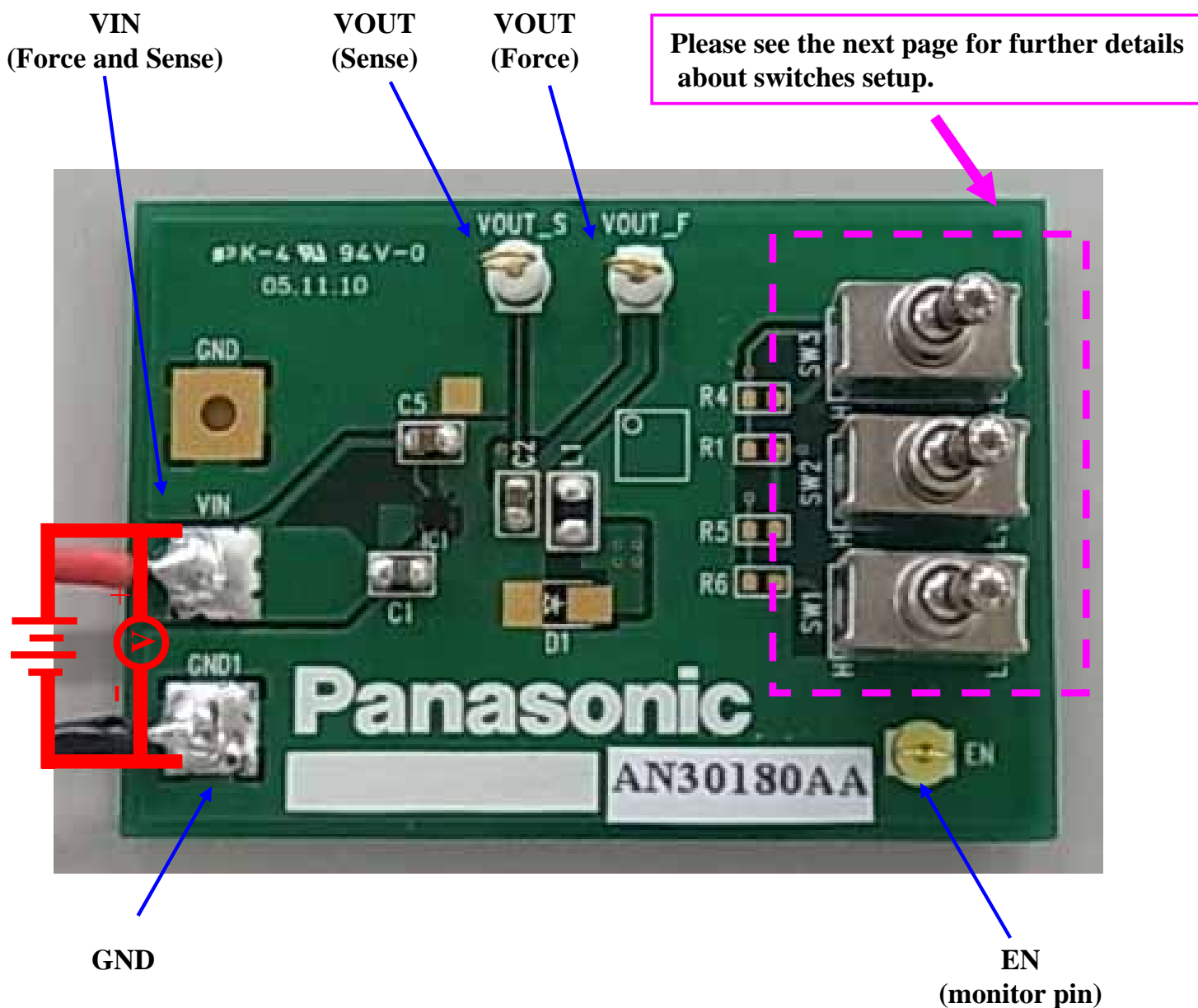

Figure 2. Appearance of Evaluation Board

Note: The parameters above is subject to change for improvement without notice.

	2013-05-07	
	Revised	

Regulations No.	180AA22E	User's Guide for Evaluation Board	AN30180AA-EVB	
			Total Pages	Page
			10	6

## 2.2 Switch Setup

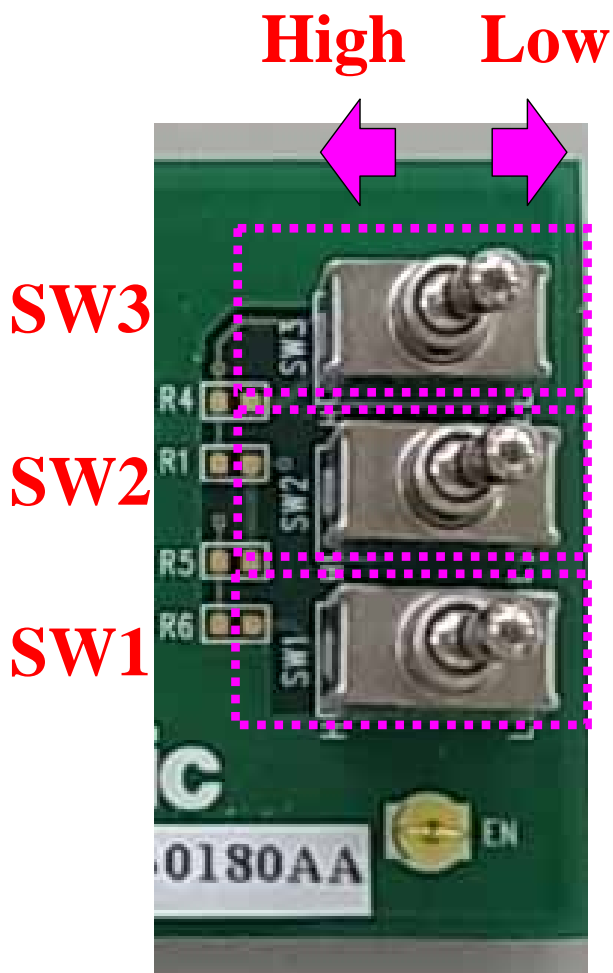

Table 2. VOUT Voltage setting

SW2	SW3	VOUT
Low	Low	1.20V
High	Low	1.35V
Low	High	1.85V
High	High	3.30V

Figure 3. Appearance of SW1 , SW2 , SW3

Table 3. Control enable/disable setting

SW1	Output ON/OFF Control
Low	OFF
High	ON

Note: The parameters above is subject to change for improvement without notice.

	2013-05-07	
	Revised	

Regulations No.	180AA22E	User's Guide for Evaluation Board		AN30180AA-EVB	
				Total Pages	Page
				10	7

### 3 Schematic

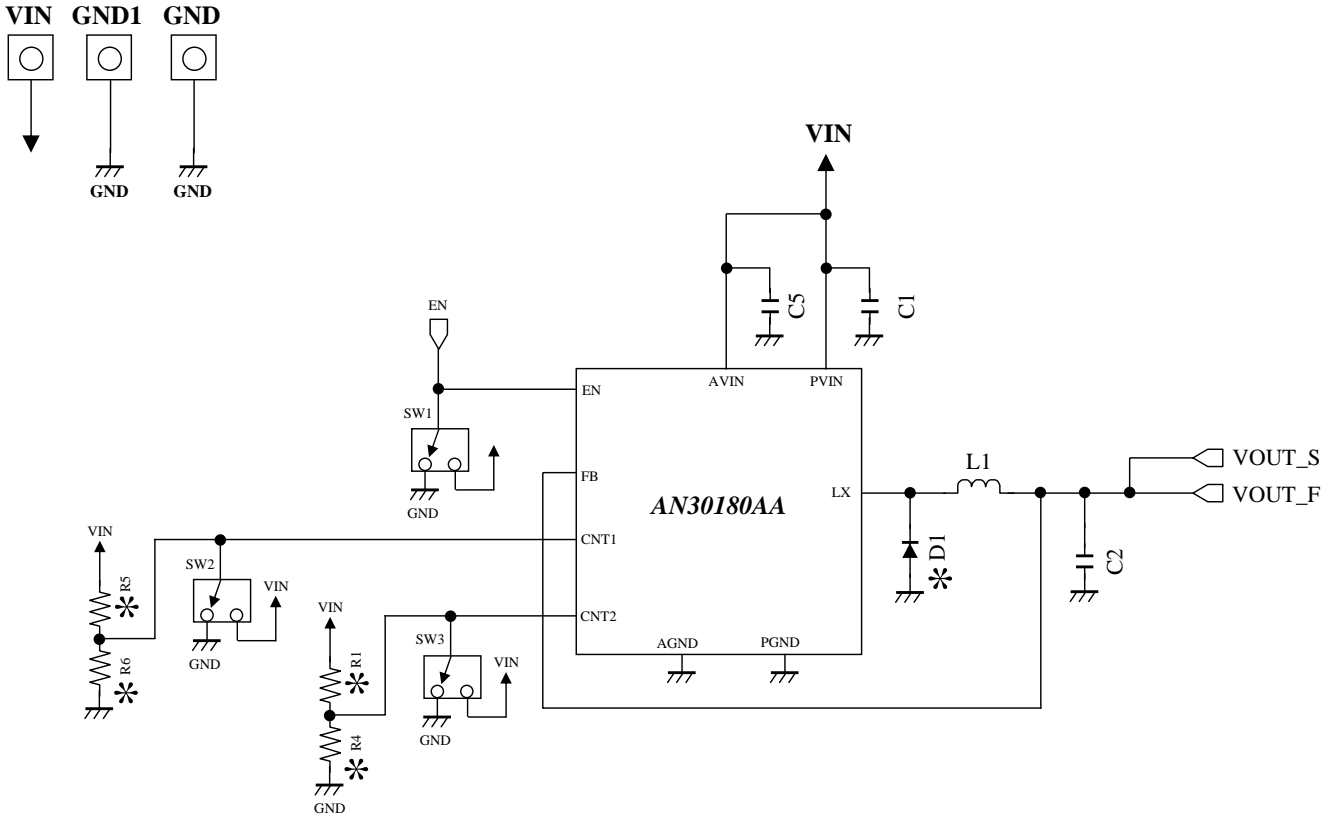

\* : Not Installed

Figure 4. Evaluation Board Schematic

Note: The parameters above is subject to change for improvement without notice.

	2013-05-07	
	Revised	

Regulations No.	180AA22E	<h1>User's Guide for Evaluation Board</h1>	AN30180AA-EVB	
			Total Pages	Page
			10	8

## 5 Bill of Materials

Table 4 presents the bill of materials for the Evaluation Board.

Table 4. Evaluation Board Bill of Materials

Reference Designator	QTY	Value	Description	Size *1	Manufacturer	Part Number
C1	1	4.7uF	Capacitor, Ceramic, 25V, B, +-10%	0805	Murata	GRM21BB31E475KA75
C2	1	4.7uF	Capacitor, Ceramic, 25V, B, +-10%	0805	Murata	GRM21BB31E475KA75
C5	1	4.7uF	Capacitor, Ceramic, 25V, B, +-10%	0805	Murata	GRM21BB31E475KA75
L1	1	1.0uH	Inductor, 1.2A	2.0 x 1.2 x 1.0 mm	FDK	MIPSZ2012D1R0

\*1 : These values comply with EIA standards.

Note: The parameters above is subject to change for improvement without notice.

	2013-05-07	
	Revised	



Regulations No.	180AA22E	User's Guide for Evaluation Board	AN30180AA-EVB	
			Total Pages	Page
			10	9

## 6 Board Layout

The board layout for the evaluation board is shown in Figure 5 through Figure 6.

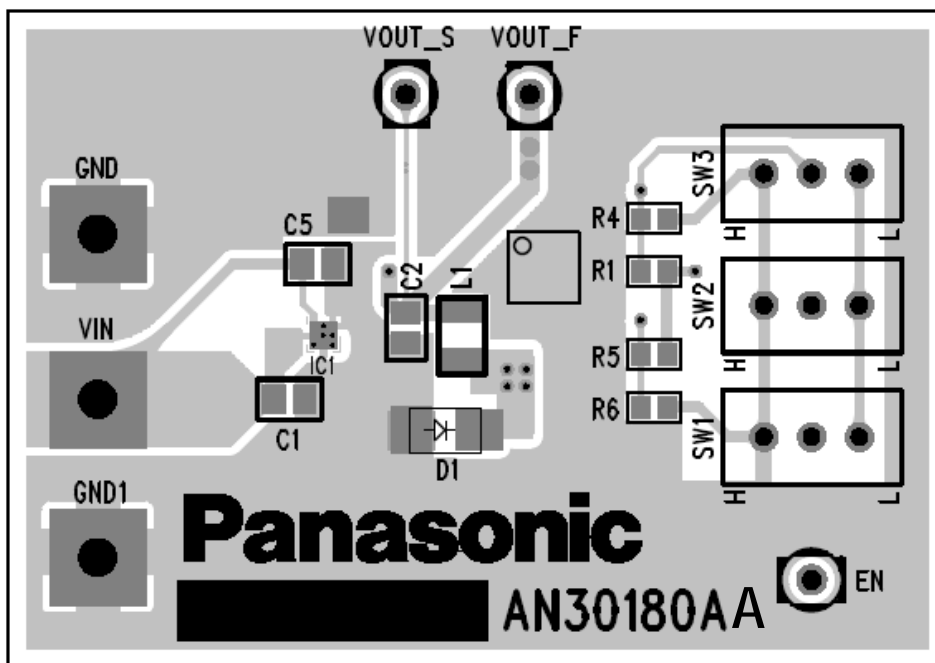

Figure 5. Top Layer with silk screen ( Top View )

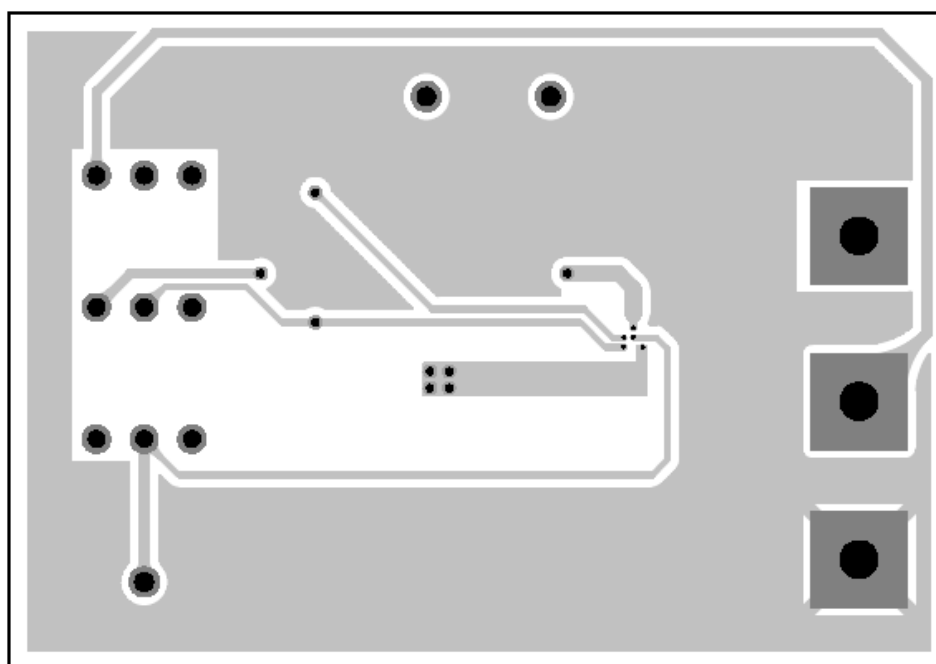

Figure 6. Bottom Layer ( Bottom View )

Note: The parameters above is subject to change for improvement without notice.

	2013-05-07	
	Revised	

Regulations No.	180AA22E	<h1>User's Guide for Evaluation Board</h1>	AN30180AA-EVB	
			Total Pages	Page
			10	10

## IMPORTANT NOTICE

1. When using the IC for new models, verify the safety including the long-term reliability for each product.
2. When the application system is designed by using this IC, please confirm the notes in this book.  
Please read the notes to descriptions and the usage notes in the book.
3. This IC is intended to be used for general electronic equipment.  
Consult our sales staff in advance for information on the following applications: Special applications in which exceptional quality and reliability are required, or if the failure or malfunction of this IC may directly jeopardize life or harm the human body. Any applications other than the standard applications intended.
  - (1) Space appliance (such as artificial satellite, and rocket)
  - (2) Traffic control equipment (such as for automotive, airplane, train, and ship)
  - (3) Medical equipment for life support
  - (4) Submarine transponder
  - (5) Control equipment for power plant
  - (6) Disaster prevention and security device
  - (7) Weapon
  - (8) Others : Applications of which reliability equivalent to (1) to (7) is required

Our company shall not be held responsible for any damage incurred as a result of or in connection with the IC being used for any special application, unless our company agrees to the use of such special application.  
However, for the IC which we designate as products for automotive use, it is possible to be used for automotive.
4. This IC is neither designed nor intended for use in automotive applications or environments unless the IC is designated by our company to be used in automotive applications.  
Our company shall not be held responsible for any damage incurred by customers or any third party as a result of or in connection with the IC being used in automotive application, unless our company agrees to such application in this book.
5. Please use this IC in compliance with all applicable laws and regulations that regulate the inclusion or use of controlled substances, including without limitation, the EU RoHS Directive. Our company shall not be held responsible for any damage incurred as a result of our IC being used by our customers, not complying with the applicable laws and regulations.
6. Pay attention to the direction of the IC. When mounting it in the wrong direction onto the PCB (printed-circuit-board), it might be damaged.
7. Pay attention in the PCB (printed-circuit-board) pattern layout in order to prevent damage due to short circuit between pins. In addition, refer to the Pin Description for the pin configuration.
8. Perform visual inspection on the PCB before applying power, otherwise damage might happen due to problems such as solder-bridge between the pins of the IC. Also, perform full technical verification on the assembly quality, because the same damage possibly can happen due to conductive substances, such as solder ball, that adhere to the IC during transportation.
9. Take notice in the use of this IC that it might be damaged when an abnormal state occurs such as output pin-VCC short (Power supply fault), output pin-GND short (Ground fault), or output-to-output-pin short (load short). Safety measures such as installation of fuses are recommended because the extent of the above-mentioned damage will depend on the current capability of the power supply.
10. The protection circuit is for maintaining safety against abnormal operation. Therefore, the protection circuit should not work during normal operation.  
Especially for the thermal protection circuit, if the area of safe operation or the absolute maximum rating is momentarily exceeded due to output pin to VCC short (Power supply fault), or output pin to GND short (Ground fault), the IC might be damaged before the thermal protection circuit could operate.
11. Unless specified in the product specifications, make sure that negative voltage or excessive voltage are not applied to the pins because the IC might be damaged, which could happen due to negative voltage or excessive voltage generated during the ON and OFF timing when the inductive load of a motor coil or actuator coils of optical pick-up is being driven.
12. Product which has specified ASO (Area of Safe Operation) should be operated in ASO
13. Verify the risks which might be caused by the malfunctions of external components.
14. Due to the unshielded structure of this IC, functions and characteristics of the IC cannot be guaranteed under the exposure of light. During normal operation or even under testing condition, please ensure that the IC is not exposed to light.
15. Please ensure that your design does not have metal shield parts touching the chip surface as the surface potential is GND voltage.

	2013-05-07	
	Revised	

## Request for your special attention and precautions in using the technical information and semiconductors described in this book

- (1) If any of the products or technical information described in this book is to be exported or provided to non-residents, the laws and regulations of the exporting country, especially, those with regard to security export control, must be observed.
- (2) The technical information described in this book is intended only to show the main characteristics and application circuit examples of the products. No license is granted in and to any intellectual property right or other right owned by Panasonic Corporation or any other company. Therefore, no responsibility is assumed by our company as to the infringement upon any such right owned by any other company which may arise as a result of the use of technical information described in this book.
- (3) The products described in this book are intended to be used for general applications (such as office equipment, communications equipment, measuring instruments and household appliances), or for specific applications as expressly stated in this book. Consult our sales staff in advance for information on the following applications:
  - Special applications (such as for airplanes, aerospace, automotive equipment, traffic signaling equipment, combustion equipment, life support systems and safety devices) in which exceptional quality and reliability are required, or if the failure or malfunction of the products may directly jeopardize life or harm the human body.It is to be understood that our company shall not be held responsible for any damage incurred as a result of or in connection with your using the products described in this book for any special application, unless our company agrees to your using the products in this book for any special application.
- (4) The products and product specifications described in this book are subject to change without notice for modification and/or improvement. At the final stage of your design, purchasing, or use of the products, therefore, ask for the most up-to-date Product Standards in advance to make sure that the latest specifications satisfy your requirements.
- (5) When designing your equipment, comply with the range of absolute maximum rating and the guaranteed operating conditions (operating power supply voltage and operating environment etc.). Especially, please be careful not to exceed the range of absolute maximum rating on the transient state, such as power-on, power-off and mode-switching. Otherwise, we will not be liable for any defect which may arise later in your equipment.

Even when the products are used within the guaranteed values, take into the consideration of incidence of break down and failure mode, possible to occur to semiconductor products. Measures on the systems such as redundant design, arresting the spread of fire or preventing glitch are recommended in order to prevent physical injury, fire, social damages, for example, by using the products.
- (6) Comply with the instructions for use in order to prevent breakdown and characteristics change due to external factors (ESD, EOS, thermal stress and mechanical stress) at the time of handling, mounting or at customer's process. When using products for which damp-proof packing is required, satisfy the conditions, such as shelf life and the elapsed time since first opening the packages.
- (7) This book may be not reprinted or reproduced whether wholly or partially, without the prior written permission of our company.

# Mouser Electronics

Authorized Distributor

Click to View Pricing, Inventory, Delivery & Lifecycle Information:

[Panasonic:](#)

[AN30180AA-EVB-0](#)