

0017-02-08-01-000**MeshWorks™ Development Kit User Guide**Document No:
0017-02-08-01-000 (Issue C)**INTRODUCTION**

MeshWorks is a turnkey M2M toolset which connects sensors and control peripherals to the cloud. It simplifies wireless networking development by implementing a complete platform armed with a Python scripting tool that is fast and easy to use. Using CEL's MeshWorks Development Kit, Graphical User Interface, and powerful scripting framework, customers are able to accelerate their time to market by greatly reducing the design phase of development.

This document describes the MeshWorks Development Kit and specifically the MeshWorks Sensor Nodes and MeshWorks Gateway Node included within the Kit. For more information on MeshWorks, contact CEL at meshconnect.cel.com.

TABLE OF CONTENTS





INTRODUCTION	1
TABLE OF CONTENTS.....	2
WHAT'S INCLUDED IN THE MESHWORKS DEVELOPMENT KIT.....	3
SENSOR NODE	4
GATEWAY NODE	13
MESHWORKS PROGRAMMING AND SOFTWARE SUPPORT	13
REFERENCES	14
REVISION HISTORY.....	14
DISCLAIMER.....	15
FOR MORE INFORMATION	15
TECHNICAL ASSISTANCE.....	15

WHAT'S INCLUDED IN THE MESHWORKS DEVELOPMENT KIT

The MeshWorks development kit comes in two versions: (1) with an Ethernet gateway or (2) with a Cellular gateway.

MeshWorks™ Development Kit *Ethernet: ZMW-KIT-ETH-1*



Software Content	Hardware Content				Additional Support
 (Download Online) MeshWorks Software Suite	 x1 Gateway	 x2 Sensor Node	 x1 Micro USB Power Supply	 x1 Micro USB Cable	For more information, software download and documentation please visit: www.cel.com/MeshWorks <hr/> <ul style="list-style-type: none"> • MeshWorks Software Suite • Quick Start Guide • API Manual • Operating Manual

*MeshWorks Development Kit with **Ethernet** Gateway*

or

MeshWorks™ Development Kit *Cellular: ZMW-KIT-CELL-1*



Software Content	Hardware Content				Additional Support
 (Download Online) MeshWorks Software Suite	 x1 Gateway	 x2 Sensor Node	 x1 Micro USB Power Supply	 x1 Micro USB Cable	For more information, software download and documentation please visit: www.cel.com/MeshWorks <hr/> <ul style="list-style-type: none"> • MeshWorks Software Suite • Quick Start Guide • API Manual • Operating Manual

*MeshWorks Development Kit with **Cellular** Gateway*

SENSOR NODE

The MeshWorks Sensor Node comes with a number of sensors which are already connected to the MeshWorks platform. You can use it to quickly test concepts, or connect your own devices to the built-in expansion header for custom prototyping.



SENSOR NODE - Block Diagram

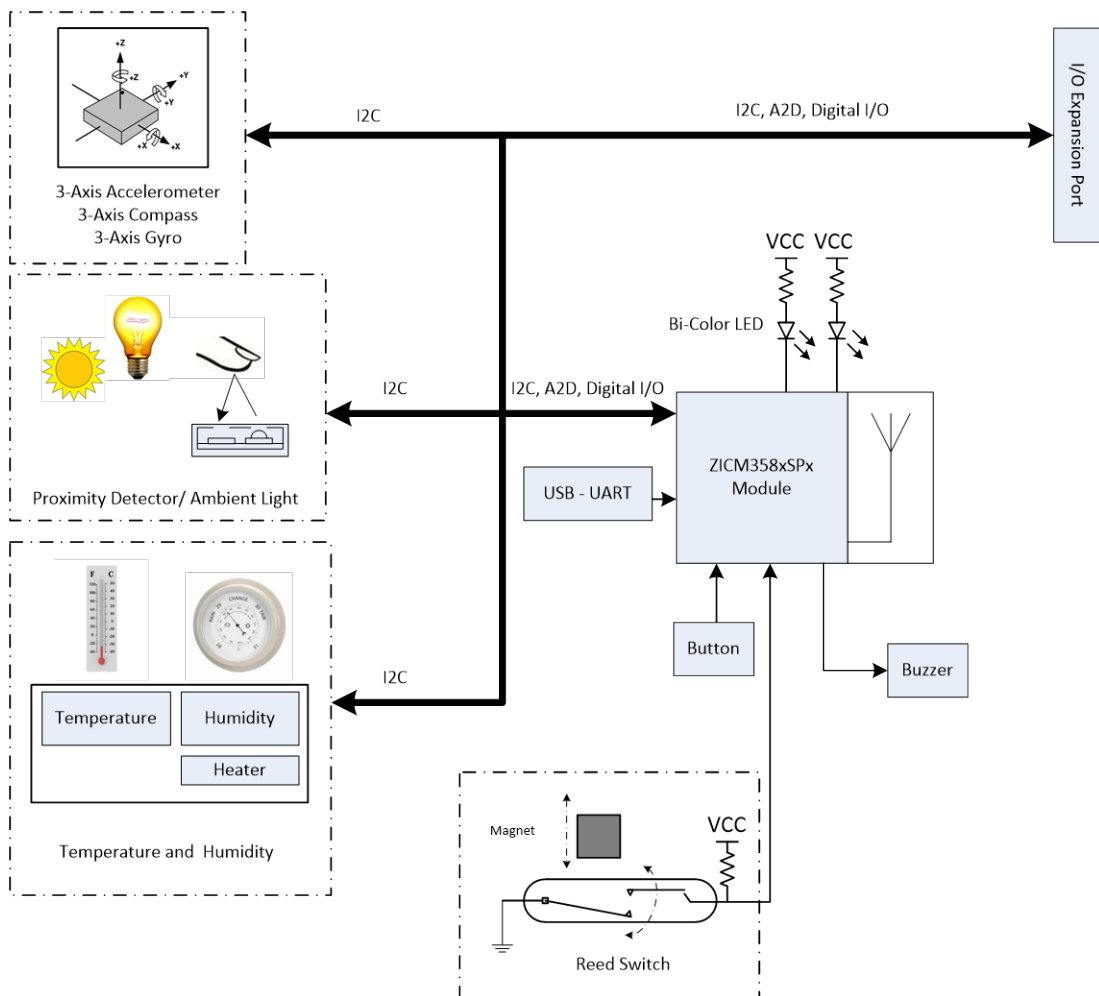

SENSOR NODE - Peripherals (Top Side)

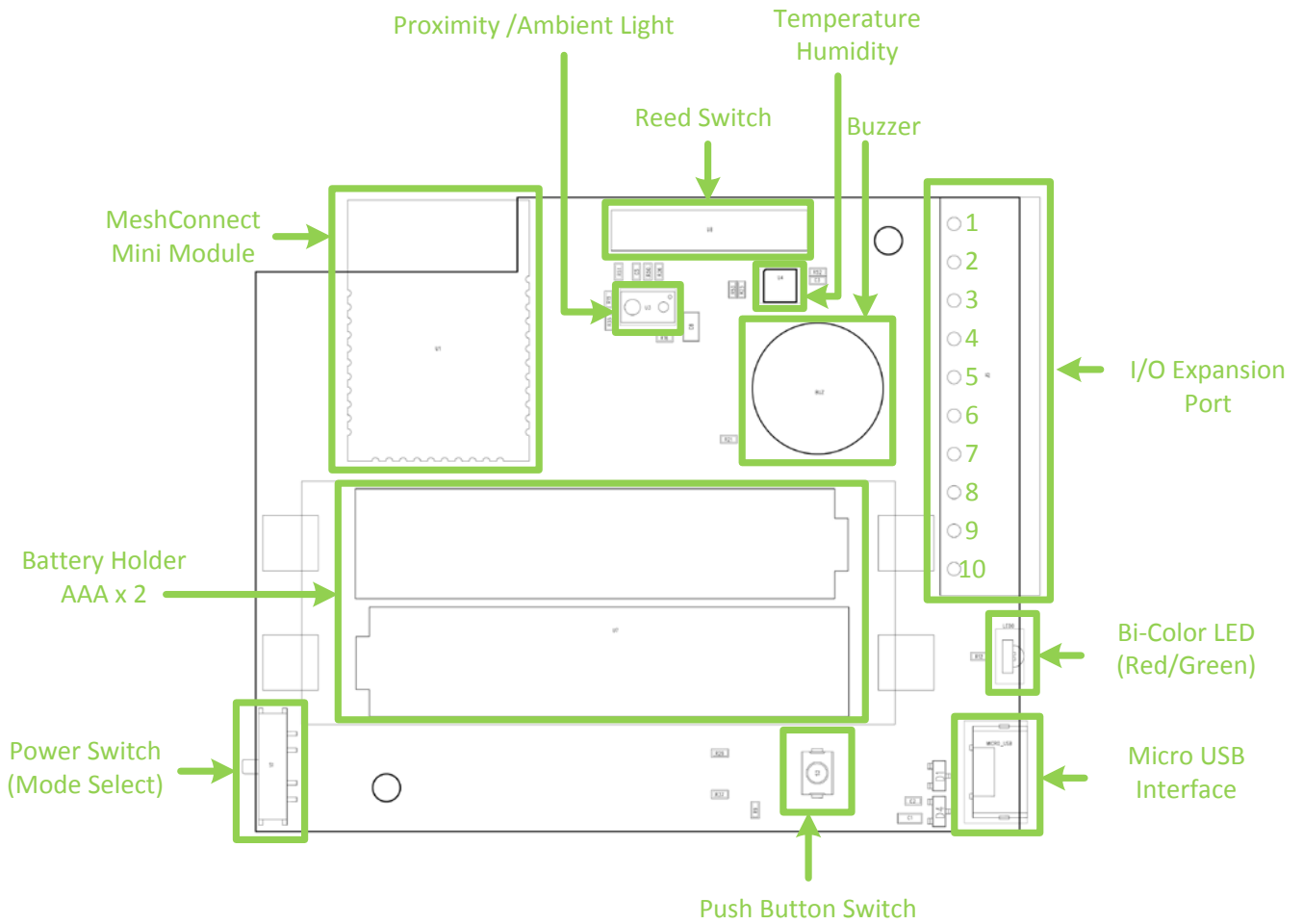

SENSOR NODE - Peripherals (Bottom Side)

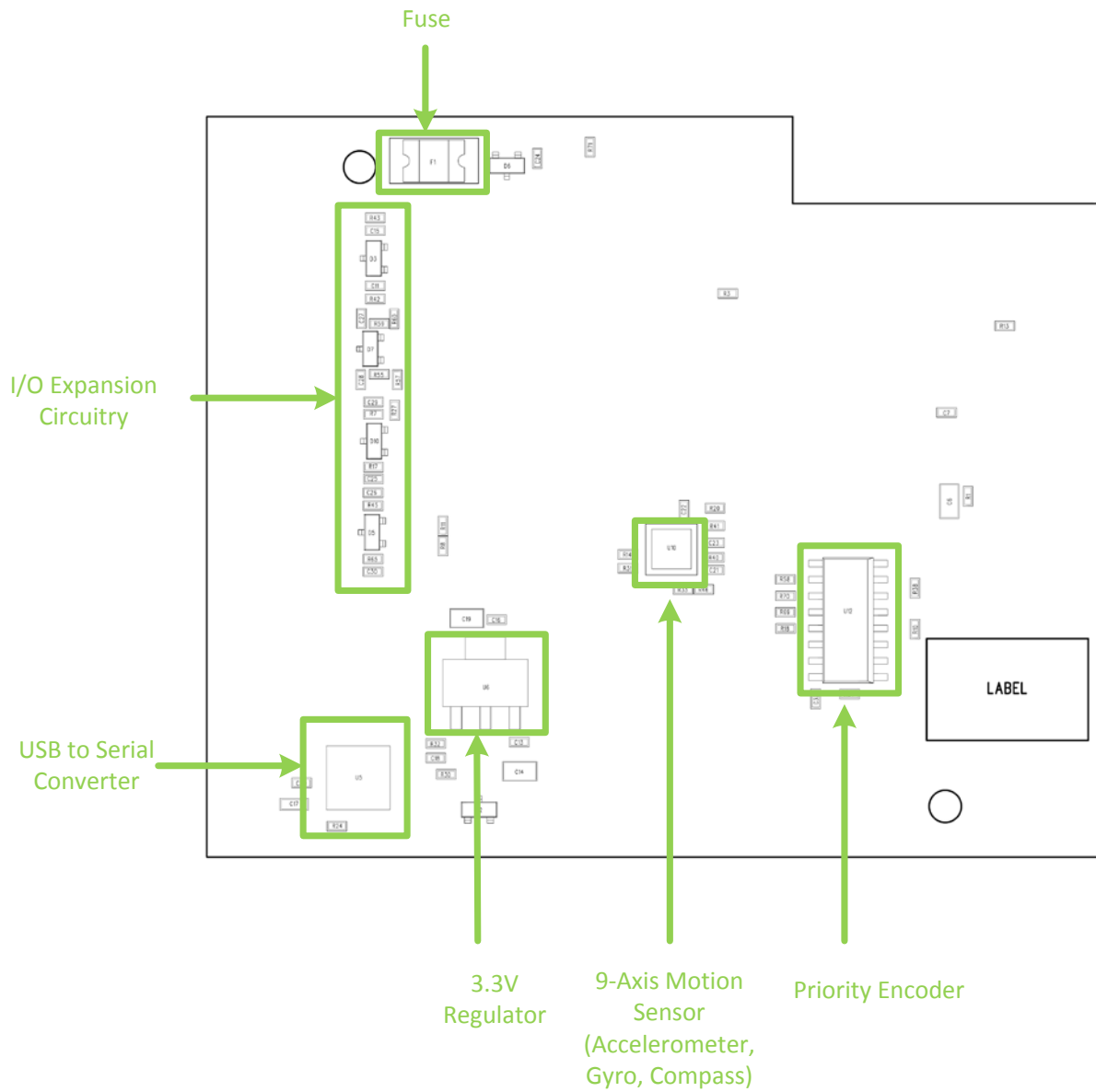

SENSOR NODE - Hardware Features

MeshWorks Mini Module and I/O Expansion Port Pin out

Mini Module	I/O Expansion Port Terminal Block	Description	Direction	Analog/Digital
PA0	8	GPIO	In/Out	Digital
PA1	3	SDA	Out	Digital
PA2	4	SCL	Out	Digital
PA3	9	GPIO	In/Out	Digital
PA4	10	ADC, GPIO, Analog out	In/Out	Analog/Digital
PA6	-	GREEN LED	Out	Digital
PA7	-	RED LED	Out	Digital
PB1	-	UART TX	Out	Digital
PB2	-	UART RX	In	Digital
PB3	-	Priority Encoder Address A0	In	Digital
PB4	-	Reed Switch	In	Digital
PB5	6	ADC, GPIO Analog out	In/Out	Analog/Digital
PB6	-	Switch	In	Digital
PB7	-	Buzzer	Out	Digital
PC1	5	ADC, GPIO Analog out	In/Out	Analog/Digital
PC6	-	Priority Encoder Address A2	In	Digital
PC7	-	Priority Encoder Address A1	In	Digital
-	1	External 3.3V Power Supply	In/Out	VCC
-	2	External Ground	In/Out	GND
-	7	External Interrupt	In	Digital

CEL Mini Module

The MeshWorks Sensor Node contains a ZICM3588SP2-1 module. For more information on this module, please refer to the *ZICM35xSPx Datasheet*.

USB

The MeshWorks Sensor Node has an integrated USB 2.0-compliant, full-speed (12Mbps) device peripheral. It utilizes a CP2103 USB transceiver from Silicon Labs.

For more information about the CP2103, please refer to the Silicon Labs website.

CEL provides a driver for MeshWorks that has been certified for Windows 2000, Server 2003, XP, Vista, 7 and 8.



For more information, please see the MeshWorks Graphical User Interface Guide.

SENSOR NODE - Electrical Specifications Table

Parameter	Min	Typ	Max	Unit
VUSB operating input voltage @100mA	4.5	5	5.25	V
EXT_VCC	2.1	3.3	3.6	V
Battery operating input voltage @100mA	2.1	3.3	3.6	V
EXT_VCC Inline Fuse			0.5	A
I2C Frequency		400		kHz
External I/O	-0.3		3.6	V
Temperature Range	-30		70	°C

SENSOR NODE - I2C Sensors

The MeshWorks Sensor Node contains an I2C bus that connects the MeshConnect Mini Module to the following I2C Slave devices: (1) 9-Axis Motion Sensor (2) Proximity and Ambient Light Sensor, (3) Temperature and Humidity Sensor, (4) and I/O Expansion Port. The Mini Module is the master of the I2C bus.

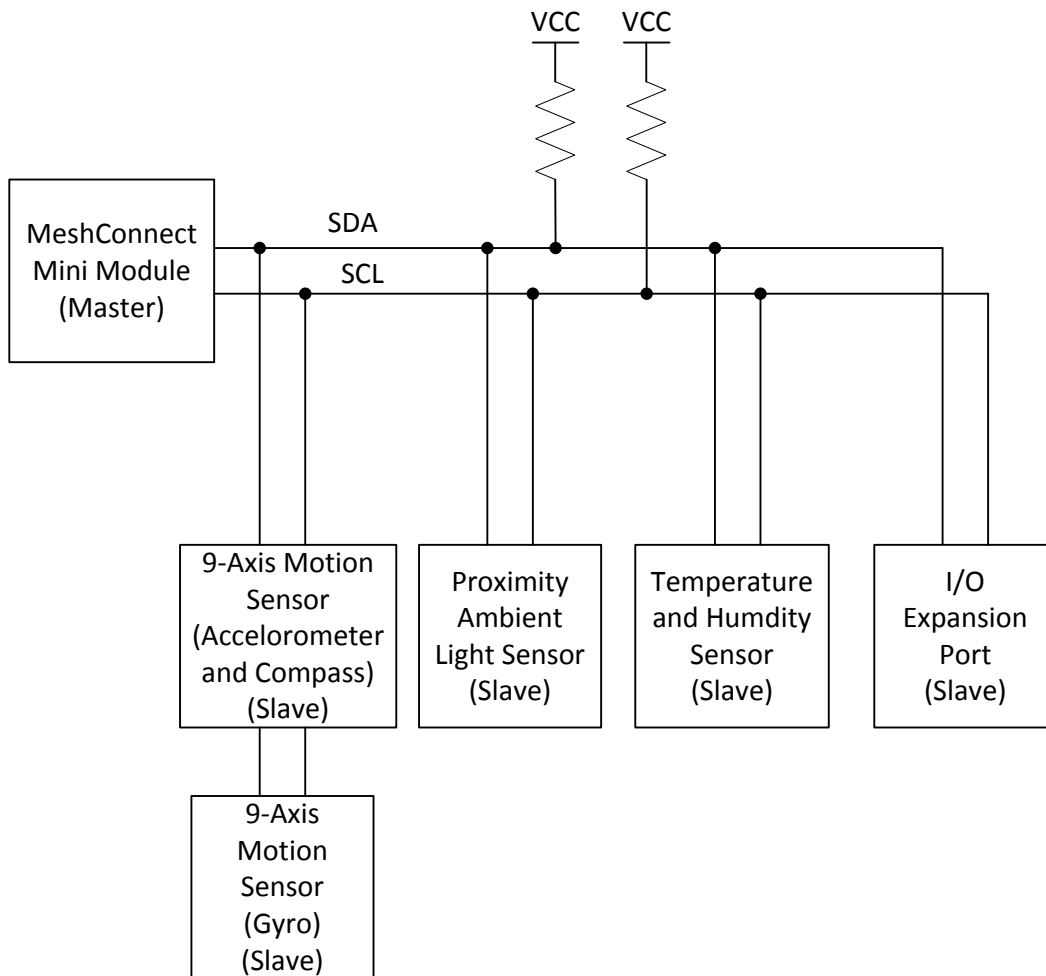

MeshWorks I2C Sensors and the corresponding I2C Address Values

Part number	I2C Address	Description
Si1143-M01	0x5A	Proximity Sensor primary address
	0x00	Proximity Sensor global address
	0x06	Proximity Sensor global reset command
MPU-9250	0x69	9-Axis Accelerometer
	0x0C	9-Axis - Compass (0x0C when pass through is enabled)
Si7013	0x40	Temp Humidity Address (A0 = 0)
	0x41	Temp Humidity Address (A0 = 1)

9- Axis Motion Sense Sensor

The MeshWorks Sensor Node includes a 9-Axis motion sensing chip from InvenSense. The MPU-9250 is a System in Package that combines two chips: the MPU-6500, which contains a 3-axis gyroscope, a 3-axis accelerometer and the AK8963, a 3-axis digital compass. For more information, please refer to the *MPU9250 Datasheet* available on the InvenSense website.

Ambient Light/Proximity Sensor

The MeshWorks Sensor Node includes a Si1143-M01 from Silicon Laboratories; this is an infrared proximity and ambient light sensor. To use this sensor, it is required to remove the top cover of the MeshWorks housing. For more information, please refer to the *Si1143-M01 Datasheet* available on the Silicon Labs website.

Temp/Humidity Sensor

The MeshWorks Sensor Node contains a Si7013 relative humidity and temperature sensor from Silicon Labs. To use this sensor, it is required to remove the top cover of the MeshWorks housing. For more information on the Si7013, please refer to Silicon Labs website.

Reed Switch (Magnet Detector)

The MeshWorks Sensor Node provides a reed switch sensor that requires a magnet for proper operation (magnet not included). The part number for this sensor is MK01-C. For more information on the MK01-C, please refer to the Meder website.

LEDs

The MeshWorks Sensor Node includes a bi-color red/green LED. Please see the MeshWorks Mini Module and I/O Expansion Port pin out table (in this document) for connection details.

Buzzer

The MeshWorks Sensor Node provides a buzzer. The buzzer serves as a pulse-width-modulated (PWM) output. Please see the MeshWorks Mini Module and I/O Expansion Port pin out table for connection details.

SENSOR NODE - Power Options

There are three different power options available for powering the MeshWorks sensor node: (1) Using a micro-USB cable connected to a PC or USB switch, (2) Connecting to an external VCC supply via the I/O Expansion Port, and (3) Running off of battery power via the 2x AAA battery holder provided within the sensor and gateway nodes.

Micro USB Power Supply / Micro USB Cable

Provided with the MeshWorks Development Kit is a Micro USB cable which is useful for powering sensor nodes in remote locations. The Micro USB cable is provided for updating scripts on Gateway and Sensor Nodes and talking directly to the Gateway.

External VCC on the I/O Expansion Port

The MeshWorks I/O Expansion port may be used to provide 3.3V power and ground. Please refer to the MeshWorks I/O Expansion Port - Terminal Block pin out table.



Battery Power

Two AAA batteries may also be used to power the sensor nodes. To use battery power, the power switch must be switched to BATT (2 x AAA required).

Power Switch Positions

The MeshWorks Sensor Node includes a power switch. The power switch has three positions:

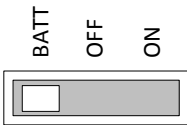
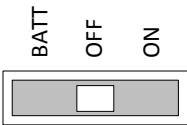
1. BATT: battery power
2. OFF: all power off
3. ON: for using (1) Micro USB, (2) External VCC

		
Battery Power (BATT) 2 x AAA required	All Power Off (OFF)	Micro-USB, External VCC (ON)

MeshWorks I/O Expansion Port – Terminal Block Schematic

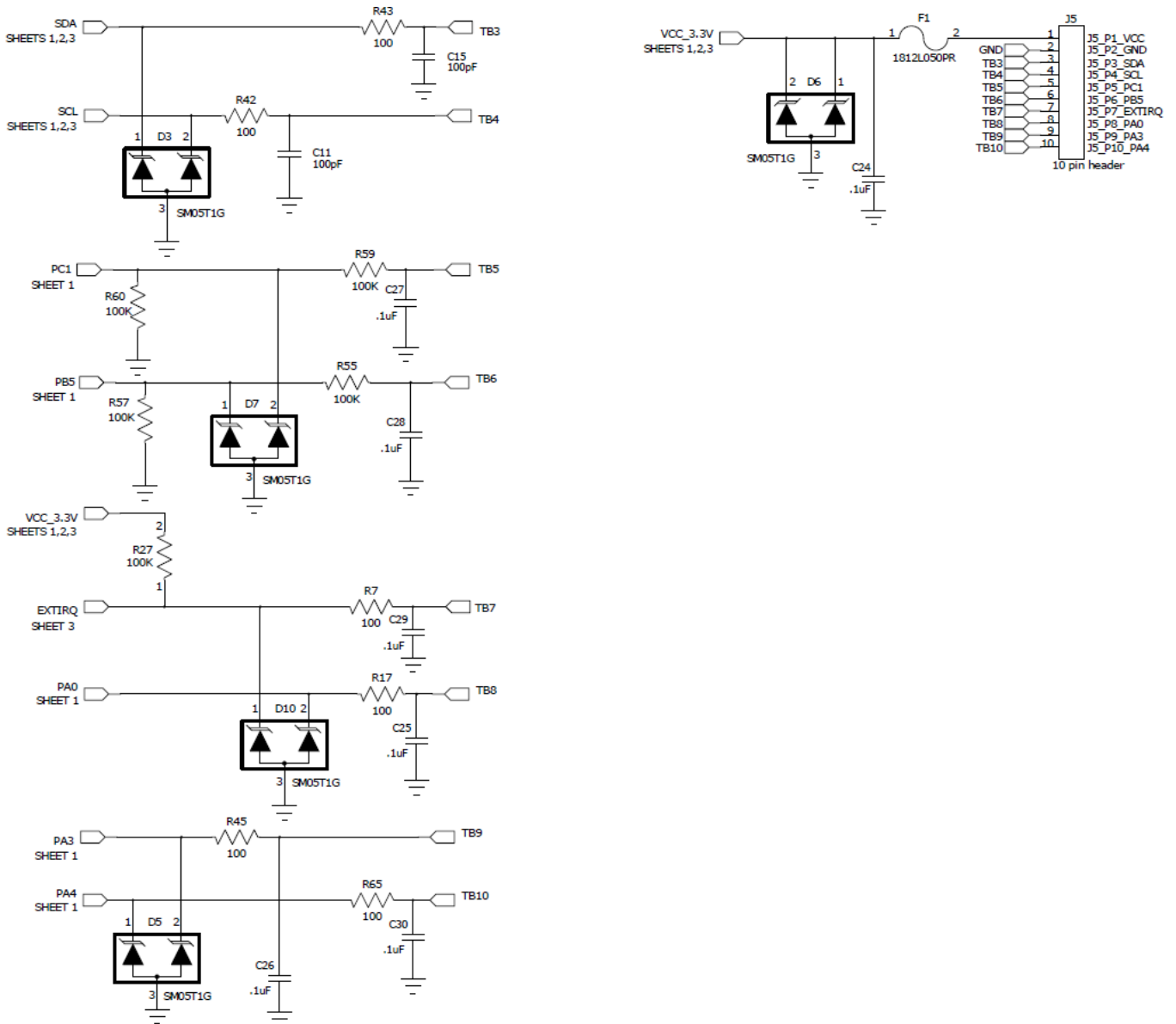

SENSOR NODE - Mechanical Info

To install or replace batteries (2 x AAA not included), you must remove four self-tapping screws as shown before the top cover can be removed. The top cover must also be removed to use the ambient light, temperature/humidity sensor and proximity sensor.



GATEWAY NODE

The Gateway Node allows you to quickly connect your local network of sensors to the cloud. It is designed to directly attach to a modem supporting the Exosite OpenTether standard.

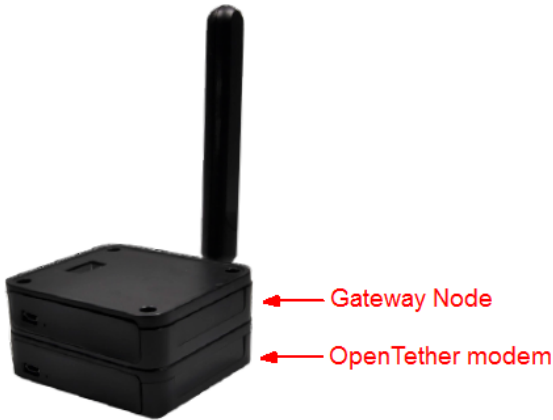

GATEWAY NODE - Power Options

There are two options for powering the Gateway Node: (1) By stacking the Gateway Node directly on an OpenTether modem, power will be delivered through the board-to-board header (VSTACK) connecting the two discs. (2) The Gateway Node can also be powered directly by using a micro-USB cable connected to a PC or USB power supply.

VSTACK - Stackable Top/Bottom Connector (with Pinouts)

VSTACK refers to the 5VDC supply line present on the OpenTether modem. This 5VDC can be shared between the Gateway Node and the OpenTether modem disc via the stackable 12 pin male-to-male connector. Powering the OpenTether modem disc with a Micro USB supply will automatically provide 5VDC to the Gateway Node.

Note: You cannot power a Sensor Node through VSTACK.

Bottom Side Stack Connector			
UART_TX	1	2	UART_RX
Vstack	3	4	GND
SPI_nSS	5	6	SPI_CLK
SPI_MISO	7	8	SPI_MOSI
Vstack	9	10	GND
I2C_SDA	11	12	I2C_SCL

Top Side Stack Connector			
UART_RX	2	1	UART_TX
GND	4	3	Vstack
SPI_CLK	6	5	SPI_nSS
SPI_MOSI	8	7	SPI_MISO
GND	10	9	Vstack
I2C_SCL	12	11	I2C_SDA

Micro USB Power Supply / Micro USB Cable

The Gateway Node can also be powered directly through a Micro USB cable. This is useful when updating its script or communicating directly with the Gateway during testing and debugging.

MESHWORKS PROGRAMMING AND SOFTWARE SUPPORT

For more information on programming and software support, please refer to the *CEL MeshWorks User Guide*, *CEL MeshWorks Scripting Language User Guide*, and the *CEL MeshWorks Firmware CLI Users Guide* on the CEL website.

REFERENCES

Reference Documents	Download
California Eastern Laboratories	
0011-00-07-00-000 EM35x Mini Module Datasheet	Link
0017-08-08-01-000 CEL MeshWorks User Guide	Link
0017-08-08-02-000 CEL MeshWorks Scripting Language User Guide	Link
0017-08-08-03-000 CEL MeshWorks Firmware CLI Users Guide	Link
Silicon Laboratories	
CP2103 Datasheet	Link
Si1143-M01 Datasheet	Link
Si7013 Datasheet	Link
InvenSense	
MPU9250 Datasheet	Link
Meder	
MK01-C Datasheet	Link

REVISION HISTORY

Previous Versions	Changes to Current Version	Page(s)
0017-02-08-01-000 (Issue A) June 20, 2014	Initial Release	N/A
0017-02-08-01-000 (Issue B) Sept 11, 2014	Added Ethernet Gateway Kit information; cleaned up document format for all pages	3, All
0017-02-08-01-000 (Issue C) May 4, 2014	<i>Updated MeshWorks I/O Expansion Port – Terminal Block Schematic</i>	11

DISCLAIMER

The information in this document is current as of the published date. The information is subject to change without notice. For actual design-in, refer to the latest publications of CEL Data Sheets or Data Books, etc., for the most up-to-date specifications of CEL products. Not all products and/or types are available in every country. Please check with a CEL sales representative for availability and additional information.

No part of this document may be copied or reproduced in any form or by any means without the prior written consent of CEL. CEL assumes no responsibility for any errors that may appear in this document.

CEL does not assume any liability for infringement of patents, copyrights or other intellectual property rights of third parties by or arising from the use of CEL products listed in this document or any other liability arising from the use of such products. No license, express, implied or otherwise, is granted under any patents, copyrights or other intellectual property rights of CEL or others.

Descriptions of circuits, software and other related information in this document are provided for illustrative purposes in semiconductor product operation and application examples. The incorporation of these circuits, software and information in the design of a customer's equipment shall be done under the full responsibility of the customer. CEL assumes no responsibility for any losses incurred by customers or third parties arising from the use of these circuits, software and information.

FOR MORE INFORMATION

For more information about CEL MeshConnect products and solutions, visit our website at www.cel.com/MeshConnect.

TECHNICAL ASSISTANCE

For Technical Assistance, visit <http://www.cel.com/MeshConnectHelp>

Mouser Electronics

Authorized Distributor

Click to View Pricing, Inventory, Delivery & Lifecycle Information:

CEL:

[ZMW-KIT-ETH-1](#)