

## POWER AMPLIFIER FOR Bluetooth™ Class 1

### DESCRIPTION

The μPG2301T5L is GaAs HBT MMIC for power amplifier which were developed for Bluetooth Class 1.

This device realizes high efficiency, high gain and high output power by using InGaP HBT. This device is housed in a 12-pin plastic TSQFN package. And this package is able to high-density surface mounting.

### FEATURES

- Operation frequency :  $f_{opt} = 2\ 400$  to  $2\ 500$  MHz (2 450 MHz TYP.)
- Supply voltage :  $V_{CC1, 2} = V_{bias} = 2.7$  to  $3.6$  V (3.3 V TYP.)
- Control voltage :  $V_{cont} = 0$  to  $3.6$  V (2.5 V TYP.)  
:  $V_{enable} = 0$  to  $3.1$  V (2.9 V TYP.)
- Circuit current :  $I_{CC} = 120$  mA TYP. @  $V_{CC1, 2} = V_{bias} = 3.3$  V,  $V_{cont} = 2.5$  V,  $V_{enable} = 2.9$  V,  
 $P_{in} = +4$  dBm
- Maximum power :  $P_{out (MAX.)} = +23$  dBm TYP. @  $V_{CC1, 2} = V_{bias} = 3.3$  V,  $V_{cont} = 2.5$  V,  $V_{enable} = 2.9$  V,  
 $P_{in} = +4$  dBm
- Gain Control Range : GCR = 23 dB TYP. @  $V_{CC1, 2} = V_{bias} = 3.3$  V,  $V_{cont} = 0$  to  $2.5$  V,  $V_{enable} = 2.9$  V,  
 $P_{in} = +4$  dBm
- Power gain :  $G_P = 23$  dB TYP. (Reference value)
- High efficiency : PAE = 50% TYP. (Reference value)
- Shut down function
- High-density surface mounting : 12-pin plastic TSQFN package (2.0 × 2.0 × 0.37 mm)

### APPLICATIONS

- Power Amplifier for Bluetooth Class 1 etc.

### ORDERING INFORMATION

Part Number	Order Number	Package	Marking	Supplying Form
μPG2301T5L-E2	μPG2301T5L-E2-A	12-pin plastic TSQFN (Pb-Free) <sup>Note</sup>	2301	<ul style="list-style-type: none"> <li>• Embossed tape 8 mm wide</li> <li>• Pin 10, 11, 12 face the perforation side of the tape</li> <li>• Qty 3 kpcs/reel</li> </ul>

**Note** With regards to terminal solder (the solder contains lead) plated products (conventionally plated), contact your nearby sales office.

**Remark** To order evaluation samples, contact your nearby sales office.  
Part number for sample order: μPG2301T5L-A

**Caution: Observe precautions when handling because these devices are sensitive to electrostatic discharge**

The information in this document is subject to change without notice. Before using this document, please confirm that this is the latest version.

**PIN CONNECTIONS**

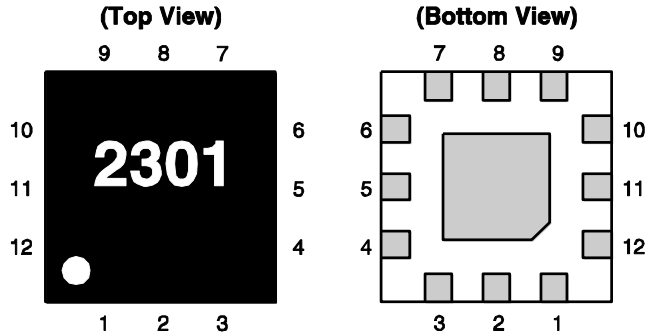

Pin No.	Pin Name
1	GND (NC)
2	GND
3	OUT/V <sub>cc2</sub>
4	GND (NC)
5	V <sub>enable</sub>
6	V <sub>bias</sub>
7	V <sub>cc1</sub>
8	GND
9	IN
10	GND (NC)
11	V <sub>cont</sub>
12	GND (NC)

**ABSOLUTE MAXIMUM RATINGS (T<sub>A</sub> = +25°C, unless otherwise specified)**

Parameter	Symbol	Ratings	Unit
Supply Voltage	V <sub>cc1, 2</sub>	5.5	V
	V <sub>bias</sub>		
Control Voltage	V <sub>cont</sub>	3.6	V
	V <sub>enable</sub>		
Circuit Current	I <sub>cc</sub>	400	mA
Control Current	I <sub>cont</sub>	0.5	mA
	I <sub>enable</sub>		
Power Dissipation	P <sub>D</sub>	700 <sup>Note</sup>	mW
Operating Ambient Temperature	T <sub>A</sub>	-40 to +85	°C
Storage Temperature	T <sub>stg</sub>	-55 to +150	°C
Input Power	P <sub>in</sub>	+10	dBm

**Note** Mounted on double-sided copper-clad 50 × 50 × 1.6 mm epoxy glass PWB, T<sub>A</sub> = +85°C

**RECOMMENDED OPERATING RANGE (T<sub>A</sub> = +25°C)**

Parameter	Symbol	MIN.	TYP.	MAX.	Unit
Operating Frequency	f <sub>opt</sub>	2 400	2 450	2 500	MHz
Supply Voltage	V <sub>cc1, 2</sub>	2.7	3.3	3.6	V
	V <sub>bias</sub>				
Control Voltage	V <sub>cont</sub>	0	2.5	3.6	V
	V <sub>enable</sub>				

**ELECTRICAL CHARACTERISTICS**

(T<sub>A</sub> = +25°C, V<sub>CC1, 2</sub> = V<sub>bias</sub> = 3.3 V, f = 2 450 MHz, External input and output matching, unless otherwise specified)

Parameter	Symbol	Test Conditions	MIN.	TYP.	MAX.	Unit
Circuit Current	I <sub>CC</sub>	V <sub>cont</sub> = 2.5 V, V <sub>enable</sub> = 2.9 V, P <sub>in</sub> = +4 dBm	110	120	130	mA
Shut Down Current	I <sub>shut down</sub>	V <sub>cont</sub> = 2.5 V, V <sub>enable</sub> = 0 V, P <sub>in</sub> = +4 dBm	–	0.1	1.0	μA
Output Power 1	P <sub>out1</sub>	V <sub>cont</sub> = 2.5 V, V <sub>enable</sub> = 2.9 V, P <sub>in</sub> = +4 dBm	+21	+23	+24.5	dBm
Output Power 2	P <sub>out2</sub>	V <sub>cont</sub> = 0 V, V <sub>enable</sub> = 2.9 V, P <sub>in</sub> = +4 dBm	–	0	+1	dBm
Gain Control Range	GCR	V <sub>cont</sub> = 0 to 2.5 V, V <sub>enable</sub> = 2.9 V, P <sub>in</sub> = +4 dBm	20	23	–	dB

**STANDARD CHARACTERISTICS FOR REFERENCE**

(T<sub>A</sub> = +25°C, V<sub>CC1, 2</sub> = V<sub>bias</sub> = 3.3 V, f = 2 450 MHz, External input and output matching, unless otherwise specified)

Parameter	Symbol	Test Conditions	MIN.	TYP.	MAX.	Unit
Efficiency	PAE	V <sub>cont</sub> = 2.5 V, V <sub>enable</sub> = 2.9 V, P <sub>in</sub> = +4 dBm	–	50	–	%
Power Gain1	G <sub>P1</sub>	V <sub>cont</sub> = 2.5 V, V <sub>enable</sub> = 2.9 V, P <sub>in</sub> = –5 dBm	–	23	–	dB
Power Gain2	G <sub>P2</sub>	V <sub>cont</sub> = 2.5 V, V <sub>enable</sub> = 2.9 V, P <sub>in</sub> = +4 dBm	–	19	–	dB

EVALUATION CIRCUIT ( $V_{cc1, 2} = V_{bias} = 3.3\text{ V}$ ,  $f = 2\ 450\text{ MHz}$ )

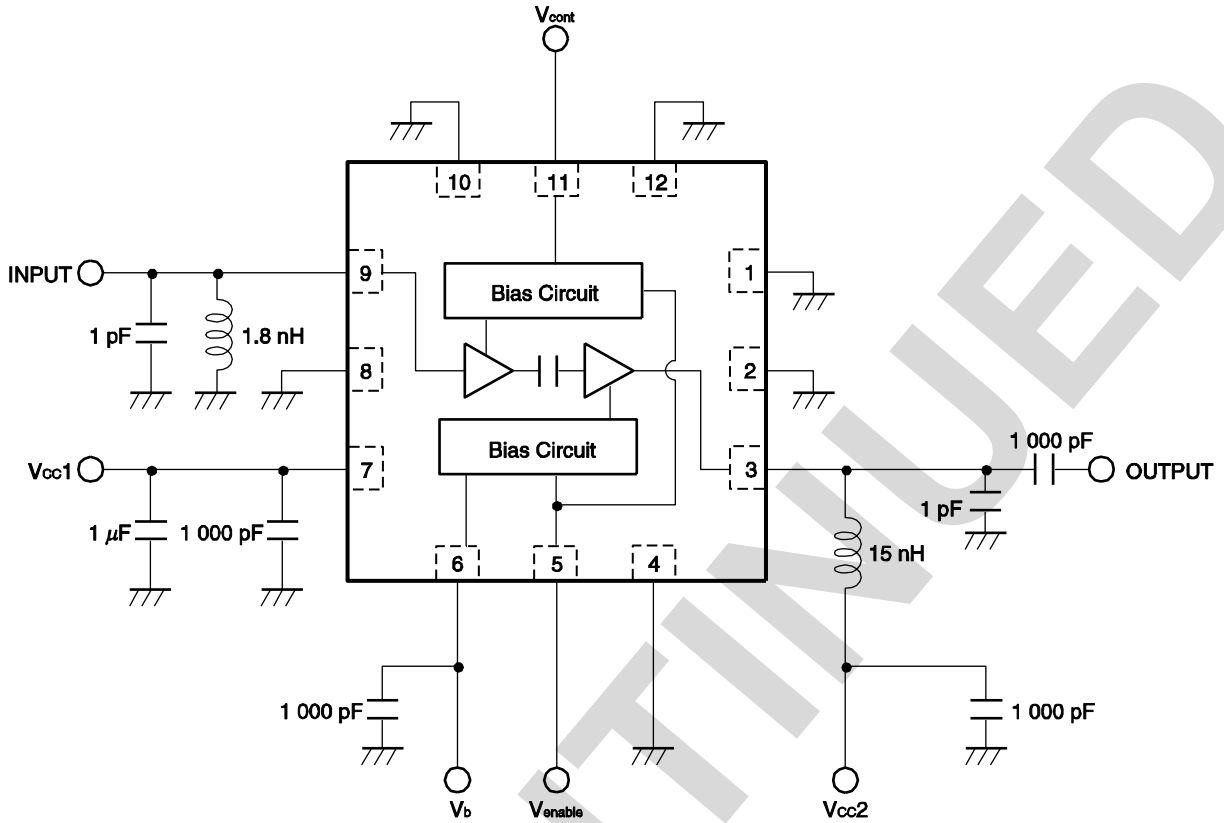

The application circuits and their parameters are for reference only and are not intended for use in actual design-ins.

PACKAGE DIMENSIONS

12-PIN PLASTIC TSQFN (UNIT: mm)

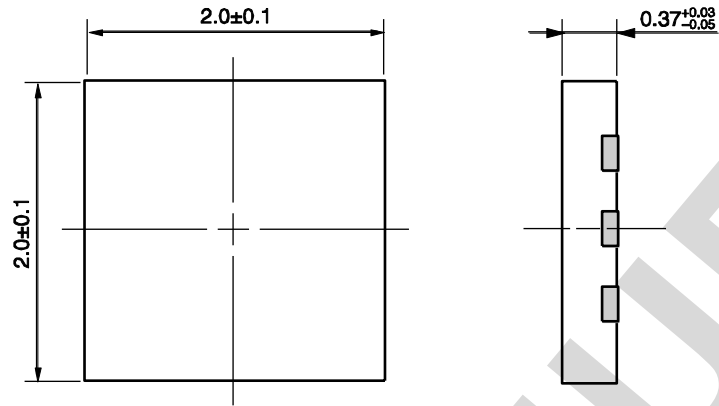

(Bottom View)

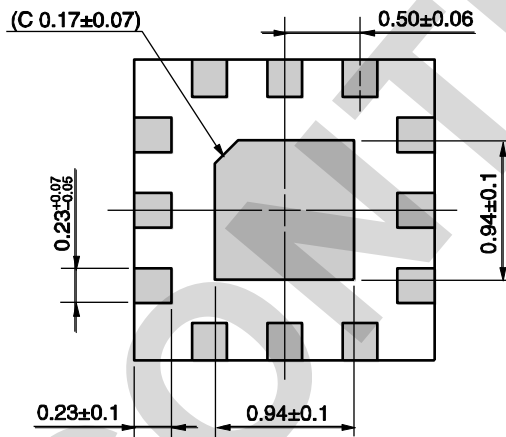

Remark ( ) : Reference value

**RECOMMENDED SOLDERING CONDITIONS**

This product should be soldered and mounted under the following recommended conditions. For soldering methods and conditions other than those recommended below, contact your nearby sales office.

Soldering Method	Soldering Conditions	Condition Symbol
Infrared Reflow	Peak temperature (package surface temperature) : 260°C or below Time at peak temperature : 10 seconds or less Time at temperature of 220°C or higher : 60 seconds or less Preheating time at 120 to 180°C : 120±30 seconds Maximum number of reflow processes : 3 times Maximum chlorine content of rosin flux (% mass) : 0.2%(Wt.) or below	IR260
Wave Soldering	Peak temperature (molten solder temperature) : 260°C or below Time at peak temperature : 10 seconds or less Preheating temperature (package surface temperature) : 120°C or below Maximum number of flow processes : 1 time Maximum chlorine content of rosin flux (% mass) : 0.2%(Wt.) or below	WS260
Partial Heating	Peak temperature (terminal temperature) : 350°C or below Soldering time (per side of device) : 3 seconds or less Maximum chlorine content of rosin flux (% mass) : 0.2%(Wt.) or below	HS350

**Caution Do not use different soldering methods together (except for partial heating).**

<p><b>Caution</b></p>	<p>GaAs Products</p>	<p>This product uses gallium arsenide (GaAs). GaAs vapor and powder are hazardous to human health if inhaled or ingested, so please observe the following points.</p> <ul style="list-style-type: none"> <li>• Follow related laws and ordinances when disposing of the product. If there are no applicable laws and/or ordinances, dispose of the product as recommended below.</li> </ul> <ol style="list-style-type: none"> <li>1. Commission a disposal company able to (with a license to) collect, transport and dispose of materials that contain arsenic and other such industrial waste materials.</li> <li>2. Exclude the product from general industrial waste and household garbage, and ensure that the product is controlled (as industrial waste subject to special control) up until final disposal.</li> </ol> <ul style="list-style-type: none"> <li>• Do not burn, destroy, cut, crush, or chemically dissolve the product.</li> <li>• Do not lick the product or in any way allow it to enter the mouth.</li> </ul>
-----------------------	----------------------	---

DISCONTINUED

# Mouser Electronics

Authorized Distributor

Click to View Pricing, Inventory, Delivery & Lifecycle Information:

CEL:

[UPG2301T5L-EVPW24-A](#)