

Differential Pressure Sensor Board SP1202S01RB Users' Guide

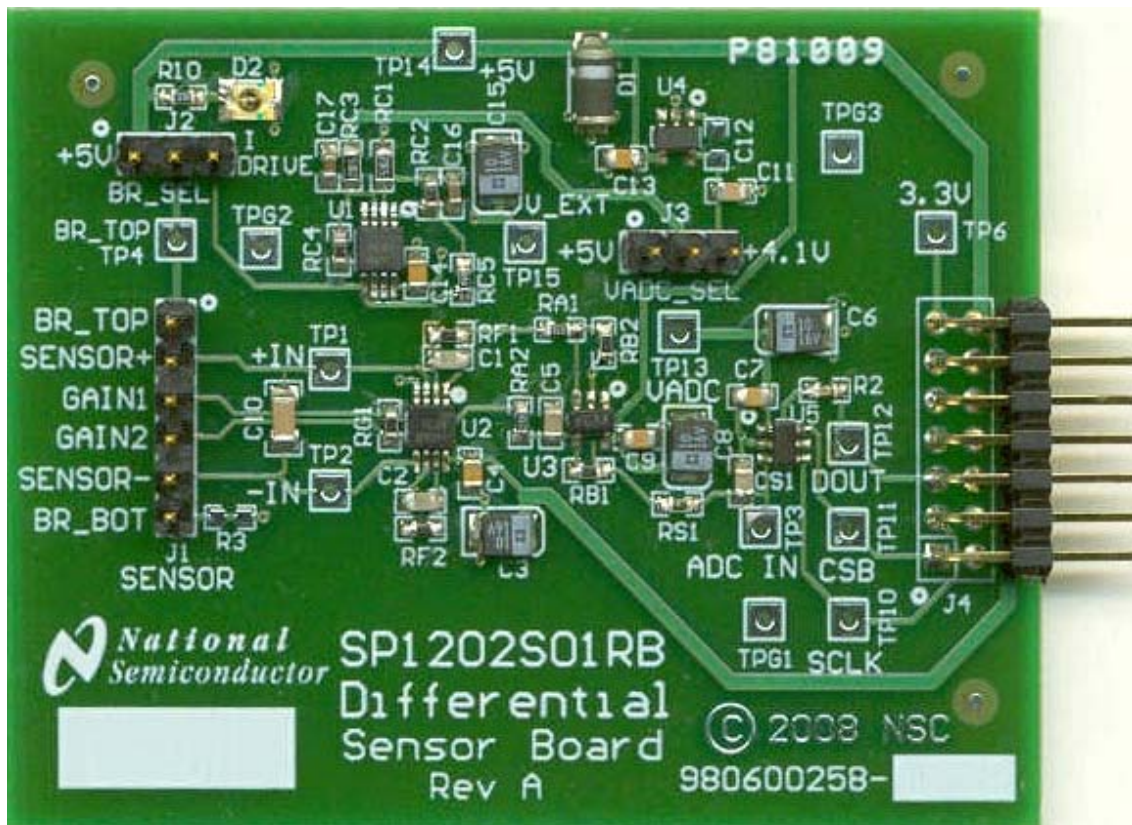

Table of Contents

1.0 Introduction.....	3
2.0 Board Assembly	3
3.0 Quick Start.....	3
4.0 Functional Description.....	4
4.1 Operational Modes	4
4.1.1 The Computer Mode	4
4.1.2 The Stand-Alone Mode	4
4.2 Signal Conditioning Circuitry	4
4.2.1 The Amplifier	4
4.2.1.1 Amplifier Gain Customization.....	4
4.2.1.2 Using Sensors with a Gain Resistor	4
4.2.2 Sensor Drive	5
4.2.2.1 Sensor Voltage Drive	5
4.2.2.2 Sensor Current Drive	5
4.2.3 Offset Correction	5
4.2.4 Non-Linearity Correction	5
4.2.5 Level Shifting.....	5
4.3 Power Supply	5
4.3.1 +3.3V up to +12V Operation	5
4.4 ADC Reference Circuitry.....	5
4.5 ADC clock.....	6
4.6 Digital Data Output.....	6
4.7 Power Requirements.....	6
5.0 Installing and Using the Sensor Path Pressure Sensor Board	6
5.1 Board Set-up	6
5.2 Quick Check of Analog Functions.....	6
5.3 Quick Check of Software and Computer Interface Operation	6
5.4 Troubleshooting	7
6.0 Evaluation Board Specifications.....	7
7.0 Example Hardware Schematic.....	8
8.0 Differential Pressure Sensor Board Example Bill of Materials.....	9
Summary Tables of Test Points and Connectors	10
Summary Tables of Test Points and Connectors (cont'd)	11

1.0 Introduction

The Differential Pressure Sensor Board (SP1202S01RB), along with the Sensor Signal Path Control Panel (Sensor Panel) software and SPUSI2 USB Interface Dongle, are designed to ease the design of circuits using various pressure sensors and load cells with National Semiconductor's amplifiers and Analog-to-Digital converters (ADCs). Use the WEBENCH® Pressure Sensor Designer tool to determine appropriate ICs and passive components to achieve your signal path requirements: <http://webench.national.com/webench5/sensors/pressure>

See *Figure 1* for component placement and *Figure 2* for example board schematic. The differential output pressure sensor is connected to header J1. The differential voltage at the sensor output (the voltage at TP1 relative to the voltage at TP2) is digitized and can be captured and displayed on the computer monitor with the accompanying **Sensor Panel** software, which operates under Microsoft Windows XP. The amplified differential voltage may be measured at TP3 relative to ground. The software can provide gain and offset correction for the entire circuit, including the sensor.

2.0 Board Assembly

This Differential Pressure Sensor Board comes as a bare board that must be assembled. Refer to the example Bill of Materials for a description of component values, to *Figure 1* for major component placement and to *Figure 2* for the Board schematic.

3.0 Quick Start

Refer to *Figure 1* for locations of test points and major components. This Quick Start procedure provides 5V excitation for the sensor.

1. Place the J2 jumper across pins 1 & 2.
2. Place the J3 jumper across pins 2 & 3.
3. Connect the Differential Pressure Sensor Board to a SPUSI2 board via 14-pin header J4 and connect a USB cable between the SPUSI2 board and a PC USB port. Red LEDs D2 on the differential Pressure Sensor Board and D1 on the SPUSI2 board should come on if the PC is on.
4. Connect the pressure sensor to 6-pin connector J1 of the board.
5. If not already installed, install the Sensor Panel software on the PC. Run the software.

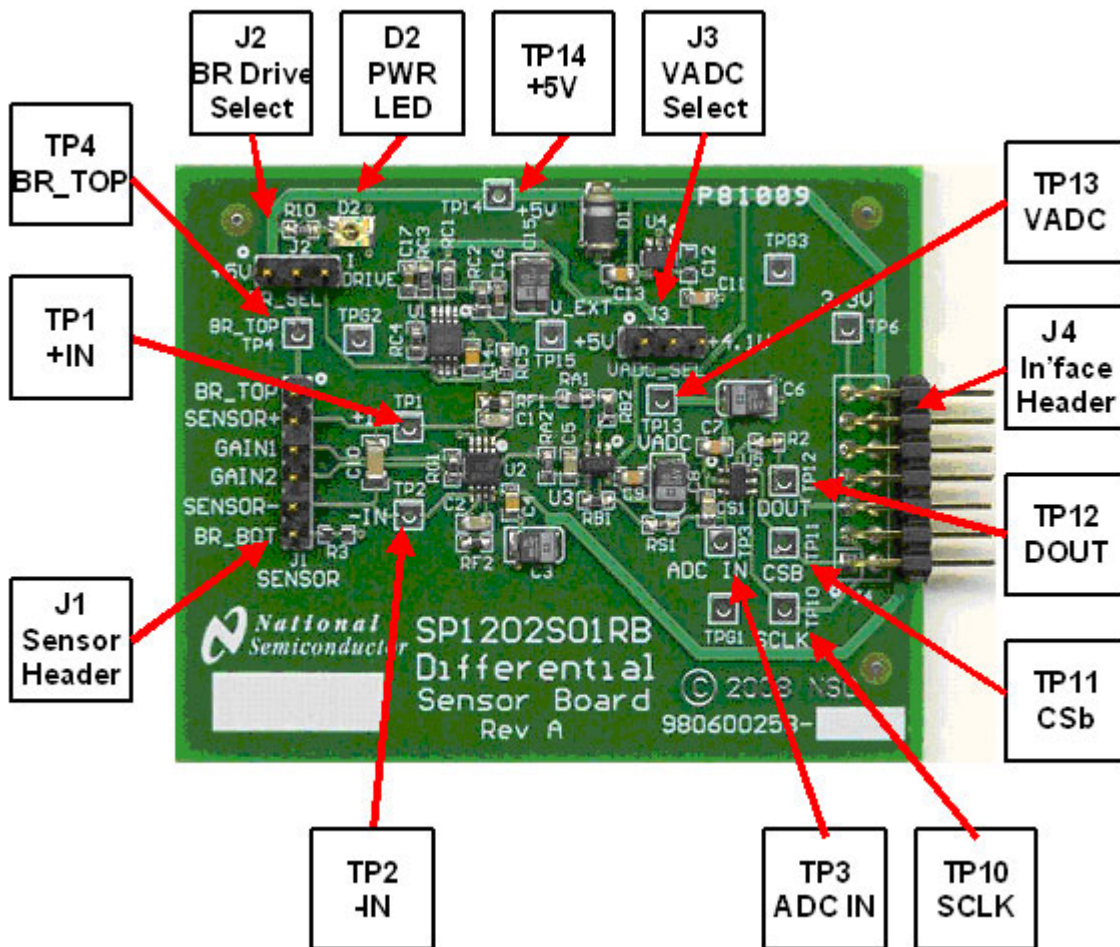

Figure 1. Component and Test Point Locations

4.0 Functional Description

The Differential Pressure Sensor Board component and test point locations are shown in *Figure 1*. The board schematic is shown in *Figure 2*.

4.1 Operational Modes

This board may be use in one of two modes: the Computer Mode using the SPUSI2 USB Interface Dongle or the Stand-Alone Mode without the use of the SPUSI2 USB Interface Dongle and a PC.

4.1.1 The Computer Mode

The board is intended for use in the Computer Mode, where a SPUSI2 board is used with it and the SPUSI2 board is connected to a PC via a USB port. Power to both boards is provided via USB.

4.1.2 The Stand-Alone Mode

The Stand-Alone Mode does not use the SPUSI2 board to capture data and upload it to a PC. To use the board this way, the user must provide +5V at pin 14 of header J4 as well as provide ADC clock and Chip Select signals to the ADC at pins 3 and 1, respectively, of J4. ADC data output is available at pin 5 of J4. Test Points TP10, TP11 and TP12 may also be used to insert/read these signals. The range of frequencies for the ADC clock is 1 MHz to 4 MHz. The CS rate can be as low as desired, but no faster than 17 times the ADC clock rate.

4.2 Signal Conditioning Circuitry

The sensor output voltage is found at TP1 relative to TP2. This voltage is amplified and digitized by U5, an ADC. The full-scale value of this voltage after amplification will depend upon the maximum sensor output and the component values. This amplified voltage is presented to the ADC (U5), whose output is at header J4.

4.2.1 The Amplifier

Most pressure sensors are used with only a positive output at the (+) terminal with respect to the (-) terminal and this is the intended use of this board. If an offset is desired because the sensor (+) terminal could be negative with respect to its (-) terminal, resistor RB2 should be returned to a positive potential equal to half of the ADC reference voltage, found at test point TP13.

Amplifiers U2A and U2B form an difference amplifier which amplifies the differential output of the bridge transducer. The gain of the difference amplifier, assuming $RF1 = RF2$, is the classic

$$\text{Differential Gain} = 1 + 2 * RF1 / RG1.$$

The differential output is converted to a single-ended signal with amplifier U3. The gain of the U3 circuit, assuming $RB1 = RB2$ and $RA1 = RA2$, is the well-known

$$\text{Single-Ended Gain} = - RB1 / RA1.$$

The overall gain from the sensor to the ADC input, then, is

$$\text{Overall Gain} = (1 + 2 * RF1 / RG1) * RB1 / RA1.$$

Because of the way the difference amplifier is connected to the final amplifier, the overall gain is positive, hence the negative sign of the final amplifier is not included in the overall gain equation.

4.2.1.1 Amplifier Gain Customization

Customization of the circuit consists primarily of adjusting the amplifier gain. As indicated above, the overall gain from the sensor to the ADC input is defined as

$$\text{Overall Gain} = AV = (1 + 2 * RF1 / RG1) * RB1 / RA1.$$

Of course, this assumes that $RF1 = RF2$, $RA1 = RA2$ and $RB1 = RB2$. Rearranging the above equation and solving for AV results in

$$RG1 = (2 * RF1 * RB1) / (AV * RA1 - RB1).$$

However, resistor tolerance can cause the ADC to reach full scale early. The solution to this is to assume $RF1$ and $RB1$ tolerance to be high and the tolerance of $RA1$ and $RG1$ to be low. This correctly implies that the required nominal value of $RG1$ should be a minimum of

$$RG1 = [(2 * H * RF1 * RB1) / (AV * L * RA1 - H * RB1)].$$

Where $H = 1 + \text{resistor tolerance}$
and $L = 1 - \text{resistor tolerance}$

For example, for a resistor tolerance 1%, $H = 1.01$ and $L = 0.99$.

4.2.1.2 Using Sensors with a Gain Resistor

Sensor output can vary by up to 50% from nominal, in some cases. Some sensors have internal gain resistors to precisely set the full scale output of the sensor. To take advantage of this, connect the gain resistor of the sensor between pins 3 and 4 of J1. Consult the sensor data sheet to determine the recommended value of $RF1$ and $RF2$, which is most often 100k-Ohms.

The data sheet will indicate the full scale output level after the differential amplifier. The second amplifier stage should have a gain such that the differential amplifier full scale output multiplied by this gain will yield the ADC reference voltage. The gain of this stage, then, should be

$$\text{Gain} = \text{ADC VREF} / \text{Diff Out}.$$

For example, one sensor calls for $RF1 = RF2 = 100\text{k-Ohms}$ for a differential output of 3.012V. The ADC reference voltage is 4.096V, therefore, the second stage gain should be

$$\text{Gain} = 4.096 / 3.012 = 1.36.$$

Setting $RB1 = RB2 = 1.33\text{k-Ohms}$ and setting $RA1 = RA2 = 1 \text{ k Ohms}$, provides a gain of 1.33 will provide a full scale input voltage to the ADC of 4.006V,

leaving a little headroom for resistor tolerances. Software adjustment of gain can then do a minor correction to precisely adjust the reading.

4.2.2 Sensor Drive

The sensor may be driven with either a voltage source or a current source. The default setup is for voltage drive of the sensor at +5V

4.2.2.1 Sensor Voltage Drive

For +5V voltage drive of the sensor, place the jumper on J2 across pins 1 and 2. This is the default setting. For voltage drive of the sensor with any other potential, place the jumper on J2 across pins 2 and 3 and provide a voltage source at TP15 that is at least 1.5 Volts greater than the desired bridge voltage. However, never exceed **12V** at P1. Resistors RC1 through RC5 (lower left of *Figure 2*) should be set as follows, where V_{BR} is the desired sensor drive voltage and VADC is the ADC supply voltage at TP13:

- Set RC1 to a convenient value less than about 5k-Ohms
- Set $RC2 = V_{BR} * RC1 / VADC - RC1$
- Set RC3 to 0 Ohms
- Remove RC4 and leave open
- Set RC5 to 0 Ohms

4.2.2.2 Sensor Current Drive

The current source provided on this board is a modified Howland Current pump, which performs quite well, but the output current does have some sensitivity to the load impedance.

The sensor may be provided with a current drive by selecting appropriate values for resistors RC1 through RC5 and providing an appropriate voltage at TP15. The values in the schematic of *Figure 2* are for a current drive of 1.5 mA.

For other current values, the WEBENCH Sensor Designer tool will provide appropriate component values.

4.2.3 Offset Correction

If offset correction is required, two axial resistors, RX1 & RX2 can be added as shown in the schematic of *Figure 2* to provide required offset. RX1 can be placed from RB2 to VADC at TP13. RX2 can be placed from RB1 to GND at TPG1. The WEBENCH Sensor Designer tool will provide appropriate RX resistor values to achieve your offset requirements.

If you have modified the board for offset correction you must use the Sensor Panel software calibration feature to capture the correct transfer function of your sensor. Note if your board has offset correction the *Amplifier Input* field in the Sensor Panel software will no longer be correct. For more details regarding the Sensor Panel software see the Manual at:

<http://www.national.com/analog/webench/sensors/spusi2>

4.2.4 Non-Linearity Correction

Because most sensors today use a small part of their full pressure range, they are very linear and there is no need for linearity correction. Consequently, there is no provision for linearity correction on this board.

4.2.5 Level Shifting

Level shifting is sometimes used to raise the amplifier output slightly when no negative supply voltage is used in the system. This allows the accurate measurement of pressures or forces at and near zero. This board does not allow for this level shifting.

4.3 Power Supply

In the Computer Mode, power to this board is supplied through header J14 and ultimately from the host PC via USB. In most cases, the only voltage needed for the Pressure Sensor board is the +5V from the USB connection. Diode D1 provides protection against reverse polarity in the Stand-Alone mode where an external supply is used. When the bridge drive circuit using U1 is used, a separate supply voltage is required to be provided at TP15.

The supply voltage source for the ADC (VADC on the schematic) is selected with JP3 to be either the 4.1V from U4, or +5V from J14.

The board is intended to be operated at +5V. However the board is capable of operation from +3.3V up to +12V.

4.3.1 +3.3V up to +12V Operation

In the Computer Mode, install a 6x2 header, lining up with pin 1 marker and leaving pins 13 & 14 unconnected. Alternatively, break 2 pins (13 & 14) off the 7x2 header supplied in the Build-It kit. In Stand-Alone Mode no board modifications are required.

Set ADC supply to output of voltage reference U5 by placing the J3 jumper across pins 2 & 3. Use TP14 to externally power-up board from +3.3V up to +12V. This same voltage will power bridge when J2 jumper is placed across pins 1 & 2. If greater voltage is necessary to power bridge leave J2 jumper open and use TP4 to power bridge with another external power supply.

If board is operated at +5.25V and below you may also set ADC supply to board supply by placing the J3 jumper across pins 1 & 2.

4.4 ADC Reference Circuitry

The single-ended ADC121S021 uses its supply voltage as its reference, so it is important that its supply voltage be stable and quiet. A 4.1V reference voltage is provided by U4, an accurate LM4120-4.1.

4.5 ADC clock

The ADC clock signal is provided external to the board at header J4. The frequency of this clock should be in the range of 1 MHz to 4 MHz. A CS (Chip Select) signal is also required at J4. See the ADC data sheet for timing requirements.

4.6 Digital Data Output.

The digital output data from the ADC is available at 14-pin header J4. All digital signals to and from the ADC are present at this connector socket.

4.7 Power Requirements

Voltage and current requirements for the Differential Pressure Sensor Board are:

- Pin 14 of J4: +5.0V at **30 mA**
- Pins 2 and 4 of J4: Ground
- TP15: Depends upon sensor

5.0 Installing and Using the Sensor Path Pressure Sensor Board

This Differential Pressure Sensor board requires power as described above. The pressure sensor should be connected to J1 pins 2 and 5. It may be necessary to change the value of RG1 to provide appropriate gain for the particular sensor used. To determine the correct value of RG1 for a given application, first determine the required overall gain:

$$\text{Total Gain} = 5000 / \text{Sensor FS (mV)}$$

Then determine the correct value of RG1 according to the discussion in Section 4.2.1.1.

Alternatively, with RF1 = RF2 = 10k-Ohms, RB1 = RB2 = 2k-Ohms and RA1 = RA2 = 1k-Ohms, with all of these resistors a 1% tolerance RG1 may be set as indicated in *Table 1*. (Refer to Section 4.2.1.1.)

Sensor Sensitivity (mV/V)	Sensor Excitation (Volts)	RG1 Value (Ohms)
10	5	511
10	10	1,050
25	5	1,330
25	10	2,870
50	5	2,870
50	10	6,650
100	5	6,650
100	10	20,000

5.1 Board Set-up

Refer to *Figure 1* for locations of connectors, test points and jumpers on the board.

1. Connect The Differential Pressure Sensor board to a SPUSI2 USB Interface Dongle.

2. Be sure all jumpers are in place per *Table 2*, below.
3. Connect the sensor to J1 with the top of the bridge connected to pin 1 and the bottom of the bridge to pin 6. Connect the +output of the sensor to pin 2 and the -output of the sensor to pin 5.
4. Connect a USB cable to the SPUSI2 board and a PC.
5. Confirm that Red LED D1 on the Differential Pressure Sensor board is on, indicating the presence of power to the board.
6. If the sensor contains a gain setting resistor, connect the sensor gain set resistor across pins 3 and 4 of J1. Resistors RF1, RF2, RA1, RA2, RB1 and RB2 may have to be adjusted as previously described in Section 4.2.1.2.

Jumper	Pins Shorted	FUNCTION
J2	1 - 2	+5V Bridge Drive
J3	2 - 3	4.1V ADC Reference

5.2 Quick Check of Analog Functions

Refer to *Figure 1* for locations of connectors and test points and jumpers on the board. If at any time the expected response is not obtained, see **Section 5.4** on Troubleshooting.

1. Perform steps 1 through 4 of Section 5.1.
2. Check for 5.0V at TP14 and for 4.1V at TP13.
3. Check for 5V at TP4 (top of sensor).
4. Place a short between TP1 and TP2 and **ground these two pins**. Check for a voltage less than 70mV at TP3. Then remove the TP1 to TP2 short.
5. Apply a voltage of 2.5V at TP2 and 2.54V to TP1 and check for a voltage of between 2.5V and 4.0V at TP3.

This completes the quick check of the analog portion of the evaluation board.

5.3 Quick Check of Software and Computer Interface Operation

1. Perform steps 1 through 4 of Section 5.1.
2. Run the **SPC** Program.
3. Place a short between TP1 and TP2 and **ground these two pins** and check the **SPC** software window for an output below **70 mV**.
4. Remove the short between TP1 and TP2, but keep TP2 grounded. Apply a potential of half the sensor output to TP1 and check the **SPC** software window for an output of **2.0V** and **2.1V**.

This completes the quick check of the software and computer interface.

5.4 Troubleshooting

If there is no output from the board, check the following:

- Be sure that the proper voltages and polarities are present at TP14 (+5V) and TP13 (+4.1V or +5V, as selected with J3).
- Be sure there is a clock signal at TP10 when trying to capture data.
- If using an actual sensor, be sure that the positive sensor output terminal is at J1 pin 2 and the negative sensor output terminal is at J1 pin 5. The voltage at TP1 should be equal to or greater than the voltage at TP2.

If the amplifier output at TP3 can not be brought within 70 mV of ground, check the following:

- Be sure there is a voltage at TP4 (top of sensor).
- Be sure that the voltage on pin 6 of J1 is zero, or that an appropriate resistor is present at R3 if the short across it is cut.

If the ADC output is zero or a single code, check the following:

- Be sure that the proper voltages and polarities are present at TP14 (+5V) and TP13 (+4.1V or +5V, as selected with J3).
- Be sure that J4 is properly connected to a SPUSI2 USB Interface Dongle, and that there is a jumper on J3.
- If using an actual sensor, be sure that the positive sensor output terminal is at J1 pin 2 and the negative sensor output terminal is at J1 pin 5. The voltage at TP1 should be equal to or greater than the voltage at TP2.

6.0 Evaluation Board Specifications

Board Size: 2.6" x 2.5" (6.6 cm x 6.35 cm)

Power Requirements: +5V (30mA) at J4 pin 14

7.0 Example Hardware Schematic

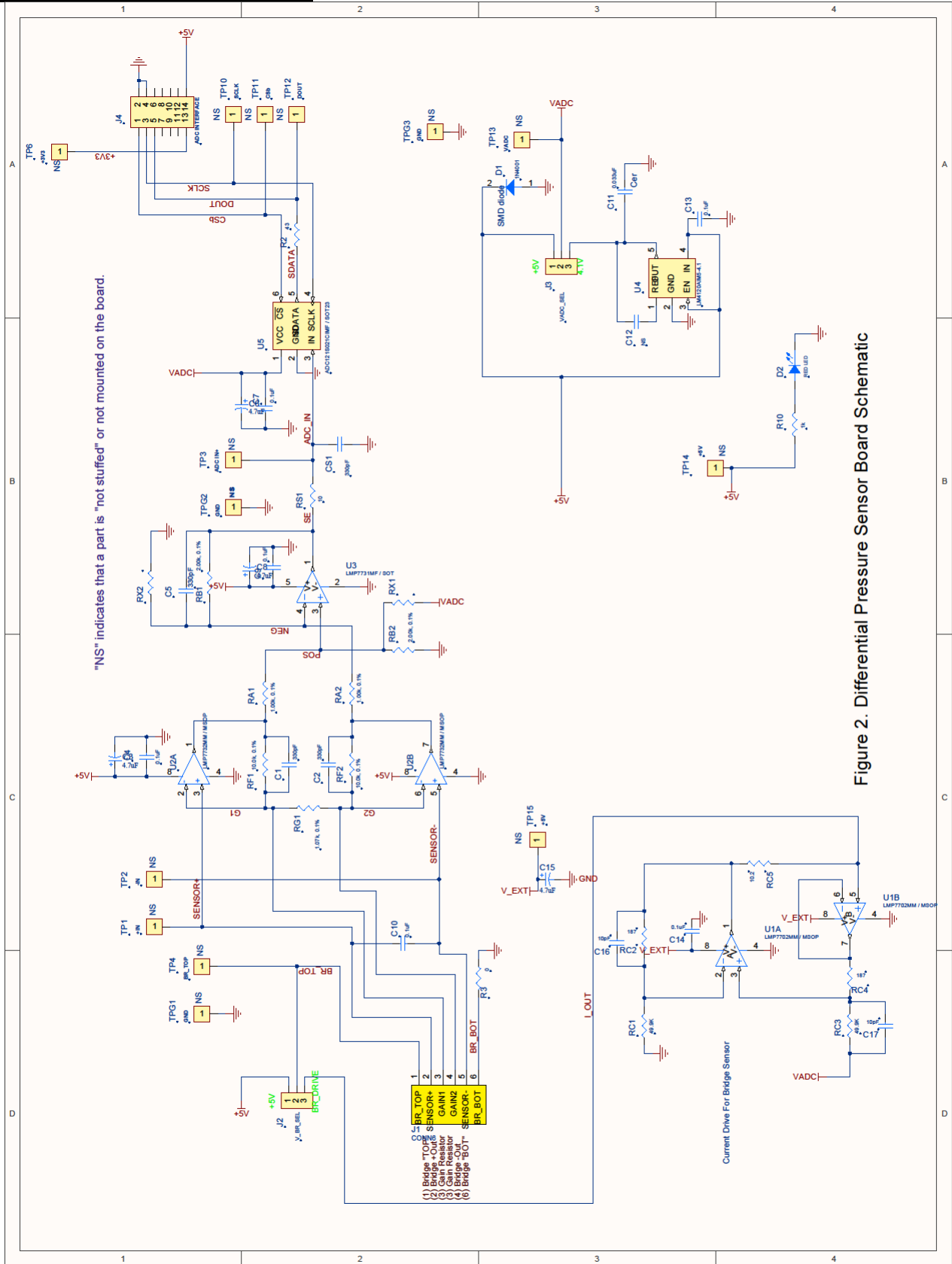

8.0 Differential Pressure Sensor Board Example Bill of Materials

Item	Qty	Reference	Part	Source
1	4	CS1, C1, C2, C5	330pF, 50V, ±10%, 0805, X7R	Kemet #C0805C331K5RACTU Digi-Key #399-1140-2-ND
2	4	C3, C6, C8, C15	4.7µF, 16V, Tant, ±20%, size "B"	Vishay/Sprague #293D475X9016A2TE3 Digi-Key #718-1148-2-ND
3	6	C4, C7, C9, C10, C13, C14	0.1µF, 16V, ±10%, 0805, X7R	Yageo #CC0805KRX7R7BB104 Digi-Key #311-1142-2-ND
4	1	C11	0.033µF, 50V, ±10%, 0805, X7R	Kemet #C0805C333K5RACTU Digi-Key #399-1165-2-ND
5	-	C12	Not Stuffed	n/a
6	6	C16, C17	10pF, 100V, ±10%, 0805, NP0	AVX #08051A100KAT2A Digi-Key #478-3731-2-ND
7	1	D1	1N4001, DO-214AA / DO-214AC	Micro Commercial #GS1A-TP Digi-Key #GS1A-TPTR-ND
8	1	D2	LED (RED)	Lite-On #LTST-C930KAKT Digi-Key #160-1461-2-ND
9	1/6	J1	6-pin Header (0.1" - breakaway)	Molex #22-28-4363 Digi-Key #WM6536-ND
10	1	J2, J3	3-pin Header (0.1")	Molex #68301-1009 Digi-Key #WM17443-ND
11	1	J4	2 x 7 Male Header RT/A (0.1")	Amp #87230-7 Digi-Key #A26599-ND
12	2	RA1, RA2	1.00k, 1%, 1/10W, 0603	Stackpole #RNCS 16 T9 1K 0.1% Digi-Key #RNCS16T91K0.1%ITR-ND
13	2	RB1, RB2	2.00k, 1%, 1/10W, 0603	Stackpole #RNCS 16 T9 2K 0.1% I Digi-Key #RNCS16T92K0.1%ITR-ND
14	2	RC1, RC3	49.9k, 1%, 1/10W, 0603	Susumu #RRG1608P-4992-B-T5 Digi-Key #RG16P49.9KBTR-ND
15	2	RC2, RC4	187, 1%, 1/10W, 0603	Susumu #RG1608P-1870-B-T5 Digi-Key #RG1608P-1870-B-T5-ND
16	1	RC5	10.2Ω, 1%, 1/10W, 0603	Yageo #RT0603BRE0710R2L Digi-Key #RT0603BRE0710R2L-ND
17	2	RF1, RF2	10.0k, 1%, 1/10W, 0603	Bourns#CRT0603-BY-1002ELF Digi-Key #CRT0603-BY-1002ELFCT-ND
18	1	RG1	1.07k, 1%, 1/10W, 0603	Susumu #RG1608P-4530-B-T5 Digi-Key #RG16P453BCT-ND
19	1	RS1	10Ω, 5%, 1/10W, 0603	Rohm #MCR03EZPJ100 Digi-Key #RHM10GCT-ND
20	1	R3	0Ω, 5%, 1/10W, 0603	Rohm #MCR03EZPJ000 Digi-Key #RHM0.0GCT-ND
21	1	R2	43Ω, 1%, 1/10W, 0603	Susumu #RG1608P-433-B-T5 Digi-Key #RG16P43.0KBTR-ND
22	1	R7	1k, 5%, 1/10W, 0603	Rohm #MCR03EZPJ152 Digi-Key #RHM1.5KGTR-ND
23	2	RX1, RX2	Selected by WEBENCH	Note resistors are axial resistors. There is no footprint on board.
24	-	TPG1, TPG2, TPG3	Not Stuffed	n/a
25	-	TP1, TP2, TP3, TP4, TP6, TP10, TP11, TP12, TP13, TP14, TP15	Not Stuffed	n/a
27	1	U1	LMP7702/MSOP	Nat Semi #LMP7702MM/NOPB Digi-Key #LMP7702MMTR-ND
28	1	U2	LMP7732MM/MSOP	Nat Semi #LMP7732MM/NOPB Digi-Key #LMP7732MMTR-ND
29	1	U3	LMP7731/SOT	Nat Semi #LMP7731MF/NOPB Digi-Key #LMP7731MFTR-ND
30	1	U4	LM4120AIM5-4.1	Nat Semi #LM4120AIM5-4.1/NOPB Digi-Key #LM4120AIM5-4.1TR-ND
31	1	U5	ADC121S021CIMF/SOT23	Nat Semi #ADC121S021CIMF/NOPB Digi-Key #ADC121S021CIMFTR-ND
32	1	PCB	SP1202S01RB	Advanced Circuits

APPENDIX

Summary Tables of Test Points and Connectors

Test Points on the Differential Pressure Sensor Board

Identifier	Name	Function
TP 1	+IN	(+) Input from Bridge
TP 2	-IN	(-) Input from Bridge
TP 3	ADC IN+	ADC +Input voltage
TP 4	BR_TOP	Top of bridge
TP 5	-	Identifier not used
TP 6	+3V3	+3.3V from SPUSI2 Board (not used on this board)
TP 7	-	Identifier not used
TP 8	-	Identifier not used
TP 9	-	Identifier not used
TP 10	SCLK	SCLK input for ADC
TP 11	CSb	CSb input for ADC
TP 12	DOUT	SDATA output from ADC
TP 13	VADC	ADC supply voltage/reference
TP 14	+5V	Overall supply for board from SPUSI2 Board
TP 15	V_EXT	Bridge Driver Amplifier supply voltage
TPGx	GND	Ground

J1 Connector - Sensor Interface

Identifier	Name	Function
J1-1	Bridge "TOP"	Positive sensor excitation
J1-2	Bridge +Out	+ Output from Sensor
J1-3	Gain Resistor	Gain Resistor Connection
J1-4	Gain Resistor	Gain Resistor Connection
J1-5	Bridge -Out	- Output from Sensor
J1-6	Bridge "BOT"	Ground or negative sensor excitation

J2 Jumper - V_BR_SEL

Shorted Positions	Results
1 - 2	+5V Drive of Sensor
2 - 3	U1 Drive of Sensor(Voltage or Current, depending upon components around U1)

J3 Jumper - VADC_SEL

Shorted Positions	Results
1 - 2	+5V for ADC Supply and Reference Voltage
2 - 3	+4.1V for ADC Supply and Reference Voltage

Summary Tables of Test Points and Connectors (cont'd)

J7 Connector - Connection to SPUSI2 Board

J7 Pin Number	Voltage or Signal
1	CSb input to ADC
2	Ground
3	SCLK input to ADC
4	Ground
5	SDATA output from ADC
6	no connection
7	no connection
8	no connection
9	no connection
10	no connection
11	no connection
12	no connection
13	+3.3V from SPUSI2 USB Interface Dongle
14	+5V from SPUSI2 USB Interface Dongle

[Blank Page]

The Differential Pressure Sensor Board is intended for product evaluation purposes only and is not intended for resale to end consumers, is not authorized for such use and is not designed for compliance with European EMC Directive 89/336/EEC.

National does not assume any responsibility for use of any circuitry or software supplied or described. No circuit patent licenses are implied.

LIFE SUPPORT POLICY

NATIONAL'S PRODUCTS ARE NOT AUTHORIZED FOR USE AS CRITICAL COMPONENTS IN LIFE SUPPORT DEVICES OR SYSTEMS WITHOUT THE EXPRESS WRITTEN APPROVAL OF THE PRESIDENT OF NATIONAL SEMICONDUCTOR CORPORATION. As used herein:

1. Life support devices or systems are devices or systems which, (a) are intended for surgical implant into the body, or (b) support or sustain life, and whose failure to perform, when properly used in accordance with instructions for use provided in the labeling, can be reasonably expected to result in a significant injury to the user.
2. A critical component is any component in a life support device or system whose failure to perform can be reasonably expected to cause the failure of the life support device or system, or to affect its safety or effectiveness.

**National Semiconductor Corporation
Americas**

Tel: 1-800-272-9959
Fax: 1-800-737-7018
Email: support@nsc.com

National Semiconductor Europe

Fax: +49 (0) 1 80-530 85 86
Email: europe.support@nsc.com
Deutsch Tel: +49 (0) 1 80-530 85 85
English Tel: +49 (0) 1 80 532 78 32
Français Tel: +49 (0) 1 80 532 93 58
Italiano Tel: +49 (0) 1 80 534 16 8

**National Semiconductor
Asia Pacific Customer
Response Group**

Tel: 65-2544466
Fax: 65-2504466
Email: sea.support@nsc.com

**National Semiconductor
Japan Ltd.**

Tel: 81-3-5620-6175
Fax: 81-3-5620-6179

www.national.com

National does not assume any responsibility for any circuitry described, no circuit patent licenses are implied and National reserves the right at any time without notice to change said circuitry and specifications.

Mouser Electronics

Authorized Distributor

Click to View Pricing, Inventory, Delivery & Lifecycle Information:

[Texas Instruments:](#)

[SP1202S01RB-PCB/NOPB](#)