

1.0 INTRODUCTION

This user's manual is for the low cost XR21V1412 RS-232 evaluation board. The XR21V1412 is in the RS-232 mode when it is shipped from the factory.

2.0 EVALUATION BOARD OVERVIEW

A block diagram of the evaluation board is shown in **Figure 1** below..

FIGURE 1. EVALUATION BOARD BLOCK DIAGRAM

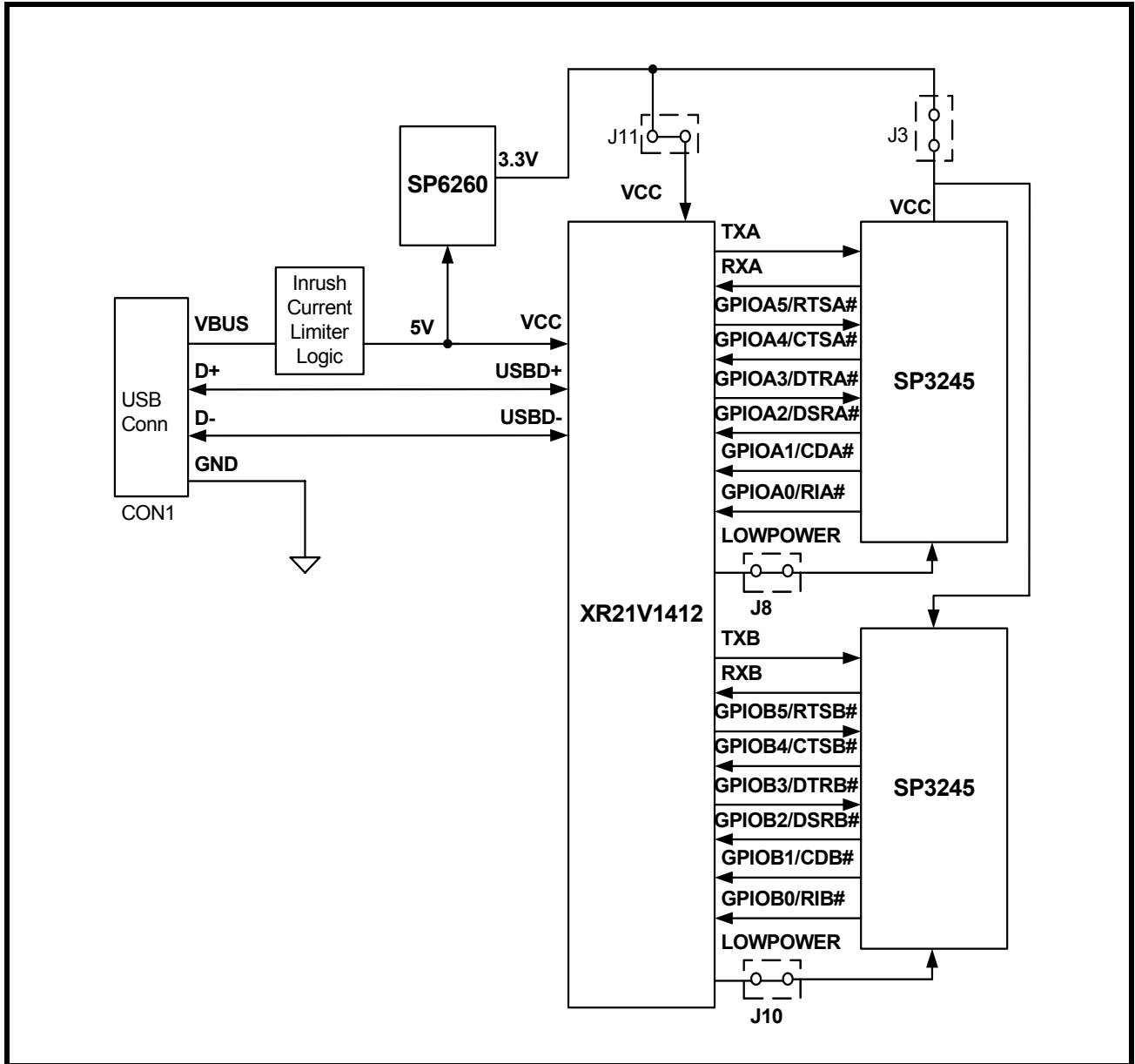

The primary devices on the XR21V1412 evaluation board are all Exar devices.

- The XR21V1412 is an enhanced 2-ch USB UART.
- The SP6260 is an Exar LDO that regulates the 5V from VBUS to 3.3V that is used as the supply voltage of the SP3245 and for the VCC of the XR21V1412.
- The SP3245 is Exar's RS-232 serial transceiver.

2.1 Evaluation Board Components

Table 1 shows where the Exar components are located and provides a brief description of some of the other components on the board.

TABLE 1: COMPONENTS OF THE XR21V1412 EVALUATION BOARD

UNIT	PART	FUNCTION
U1	SP6260GEK-L	Exar's 150mA RF Ultra Low Dropout Regulator used for converting 5V from VBUS to 3.3V for the SP3245 and VCC of the XR21V1412.
U2 U5	SP3245EEY-L	Exar's RS-232 transceiver.
U3	AT24C02B-PU-DIP8	EEPROM socket (not installed).
U4	AT24C02BN-SH-B-ND	I ² C Serial EEPROM. It is for storing Device ID and Vendor ID.
U6	XR21V1412IL32-F	Exar's Enhanced 2-channel USB UART.
CON1	DB9 male connector	Communicate with remote UART or device via RS-232.
SW1	Switch	Can be used to trigger remote wake-up event.

2.2 Description of Headers/Jumpers

This section describes the headers/jumpers on this evaluation board that are installed as well as the headers/jumpers that are not installed. Some headers/jumpers may not be installed because they are used for internal testing purposes only. The headers/jumpers that are installed are highlighted in **Table 2** below.

TABLE 2: DESCRIPTION OF HEADERS/JUMPERS (INSTALLED)

JUMPERS	FUNCTIONS	COMMENTS
J4	Pull-up or pull down SDA signal	<ul style="list-style-type: none"> ■ 1&2 pulls up the SDA signal. ■ 2&3 pulls down the SDA signal. (default)
J5	Pull-up or pull down SCL signal	<ul style="list-style-type: none"> ■ 1&2 pulls up the SCL signal. ■ 2&3 pulls down the SCL signal. (default)
J6	Header to easily connect to an external board/device	All of the UART channel A I/O signals are available on this header.
J9	Header to easily connect to an external board/device	All of the UART channel B I/O signals are available on this header.
J12	Selects input to RI#	<ul style="list-style-type: none"> ■ 1&2 selects RI# input from SP3245 (trace is cut) ■ 2&3 selects push button switch (default, jumper installed on 2&3)

NOTE: Pin 1 of all jumpers is designate by a square pad.



The headers/jumpers that are not installed are highlighted in **Table 3** below.

TABLE 3: DESCRIPTION OF HEADERS/JUMPERS (NOT INSTALLED)

JUMPERS	FUNCTIONS	COMMENTS
J1	In house testing.	Open.
J2	In house testing.	Trace between 1&2.
J3	Power supply for SP3245	Trace between 1&2.
J7	Connect SCL & SDA signals with EEPROM	<ul style="list-style-type: none">■ 1&2 connects the SCL signal to EEPROM.■ 3&4 connects the SDA signal to EEPROM.
J8 J10	Shut down/Enable SP3245	Trace between 1&2.
J11	Power supply for XR21V1412	Trace between 1&2.

3.0 DRIVERS AND SUPPORT

For any questions about this evaluation board, software drivers or technical support, send an e-mail to uarttechsupport@exar.com.

NOTICE

EXAR Corporation reserves the right to make changes to the products contained in this publication in order to improve design, performance or reliability. EXAR Corporation assumes no responsibility for the use of any circuits described herein, conveys no license under any patent or other right, and makes no representation that the circuits are free of patent infringement. Charts and schedules contained here in are only for illustration purposes and may vary depending upon a user's specific application. While the information in this publication has been carefully checked; no responsibility, however, is assumed for inaccuracies.

EXAR Corporation does not recommend the use of any of its products in life support applications where the failure or malfunction of the product can reasonably be expected to cause failure of the life support system or to significantly affect its safety or effectiveness. Products are not authorized for use in such applications unless EXAR Corporation receives, in writing, assurances to its satisfaction that: (a) the risk of injury or damage has been minimized; (b) the user assumes all such risks; (c) potential liability of EXAR Corporation is adequately protected under the circumstances.

Copyright 2010 EXAR Corporation

Datasheet December 2010.

Send your UART technical inquiry with technical details to hotline: uarttechsupport@exar.com.

Reproduction, in part or whole, without the prior written consent of EXAR Corporation is prohibited.

Mouser Electronics

Authorized Distributor

Click to View Pricing, Inventory, Delivery & Lifecycle Information:

Exar:

[XR21V1412IL-0B-EB](#)