



GENERAL SPECIFICATIONS (ALL MODELS)	
Insulation Class	600V, 10kV BIL full wave (1)
Frequency Range	50-400Hz
Supplied Secondary	See Table 1
Max. Secondary Lead	
Rated Accuracy	
Burden	
UL File No.	
CSA File No.	
Weight	

(1) Basic Lightning Impulse Insulation Level (BIL): The insulation strength referenced to the crest value of an impulse voltage-waveform which rises to a crest value in 1.2 microseconds, then drops to ½ the crest value in 50 microseconds.

These commercial grade, UL & CSA recognized, “donut style” AC current-transformers (CTs) provide an isolated 0-5A output that can be used with Murata Power Solutions’ ACA5 Series of digital ammeters. Installation is straightforward: simply pass the load-carrying conductor through the 5A CT’s primary window, and then route its secondary’s leads through the ACA5-ammeter’s built-in, low-burden, toroid sensor.

All models feature rugged, fully insulated construction, allowing continuous operation with primary voltages up to 600Vac, at line frequencies from 50 to 400Hz. Fourteen models are available to enable accurate measurements from 50A through 2000A. When combined with Murata Power Solutions’ ACA5 Series ammeters, secondary lead-extensions may be used for those applications where the CT cannot be installed in the immediate vicinity of the ammeter.

### TECHNICAL NOTES

**IMPORTANT!** To ensure safe and reliable operation, Current Transformers and associated equipment must be installed and serviced by qualified technical personnel. Never open the CT’s secondary connections while the primary is energized. Open CT secondary wiring can generate potentially lethal voltages when the primary circuit is energized. Contact Murata Power Solutions if you have any doubts regarding the installation or operation of any of our ac-mains measurement instruments and accessories.

1. CT Precautions: In normal operation, a 5A current transformer’s secondary circuit operates at a relatively low voltage due to its closed-loop, low burden configuration (essentially zero Ohms when used with Murata Power Solutions’ ACA5 series ammeters). However, any CT can generate potentially lethal voltages if its output current is suddenly interrupted. For example, loose secondary connections can produce a condition referred to as “inductive kick.” Inductive kick can generate extremely high voltages across the open secondary connections.

Therefore, all connections made to a CT’s secondary leads must only be performed with zero current flowing in the primary circuit. Never operate a CT with its secondary circuit open and current flowing in the primary.

2. CT Connections and Grounding: Some applications require connecting one of the CT’s 5A output terminals to earth/chassis ground. In the USA, consult the latest revision of the National Electrical Code for more information.

After all mechanical assembly is completed, pass the 5A secondary leads through the ACA5 ammeter’s built-in toroid, then connect the two leads together as shown in Figure 1. For this connection, and for connections involving lead extensions, pressure-style connectors (commonly called “wirenuts”) are acceptable as long as they are rated for the currents and voltages involved.

3. Installation: CT’s must be installed in a manner that ensures no excessive stresses are applied to the primary conductor that passes through the CT or to the secondary circuit and its associated instruments. Use plastic tie-wraps and/or other suitable non-conductive restraining devices to secure the CT.

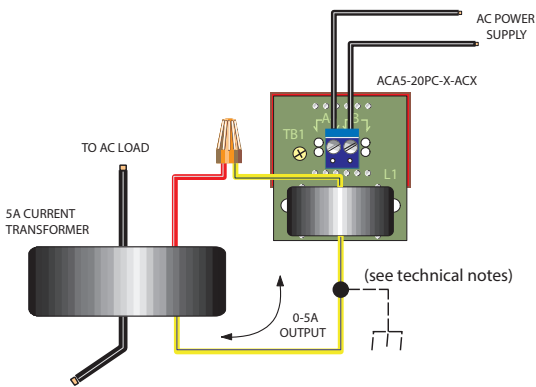

Figure 1. Typical Connections



### TECHNICAL NOTES

- Reference Documentation: Prior to connecting CTs to any measurement device (analog or digital), relay, or other apparatus, be sure to thoroughly review the applicable device's technical documentation (for example, Murata Power Solutions' ACA5-20PC product datasheet). In particular, make sure the CT's ratings meet the requirements of your application.
- Secondary Lead Extensions: When calculating the total burden imposed on a CT's 5A output, Murata Power Solutions' ACA5 digital ammeters' input impedance is negligible and can be assumed to be zero Ohms. In many applications, the length of secondary wiring can be increased up to the value specified in Table 1 without adversely affecting performance.  
  
In order to achieve the specified accuracy, the maximum permissible burden must not exceed the value shown in Table 1. When used with ACA5 ammeters, the total burden is the sum of the resistance of the CT's 24" leads and any lead-extensions. Make sure all connections are securely tightened and properly strain relieved. If terminal blocks are used for intermediary connections, refer to the manufacturer's torque recommendations.  
  
Table 1 lists general guidelines for adding lead extensions when using Murata Power Solutions' ACA5-Series ammeters as the readout device. The lengths in Table 1 assume the lead extensions are 16AWG. Stated dimensions are one-way distances between the ACA5 and the CT. Make sure all secondary extensions meet or exceed the specifications of the CT's built-in leads. In order to minimize external noise pick up, lead extensions should be as kept short as possible.
- Accuracy: The indicated accuracy specifications are valid as long as the total secondary burden does not exceed the value in Table 1's

burden column. Accuracy measurements are taken at 100% primary current, using a resistive burden and a nominal line frequency of 60Hz.

- Polarity: CTs are marked with 'H1' (primary) and 'X1' (secondary) polarity indicators. When a CT's only function is to measure amperes, polarity markings can be disregarded. However, correct polarity is mandatory in applications in which the phase relationship between two currents is involved (watt or watt-hour meters are two examples of polarity sensitive applications). Refer to the respective instruments' documentation for more information.
- Thermal Rating Factor: The thermal rating factor denotes the amount by which the primary current can be increased on a continuous basis over its rated value without exceeding the CT's maximum temperature rise.

The formula below can be used to calculate thermal rating factors at temperatures above 30°C.

$$NRF = \sqrt{\frac{(85 - NAT)(RF)^2}{NAT}}$$

NRF = Rating Factor at New Ambient Temperature

RF = 30°C Rating Factor

NAT = New Ambient Temperature

Example: Find the 55°C. thermal rating factor of a 2000:5 CT whose 30°C rating factor is 1.3.

$$NRF = \sqrt{\frac{(85 - 55)(1.3)^2}{55}} = 0.96$$

**Table 1. Selection Guide**

MPS Part No.	Current Ratio	Accuracy (@ 60Hz)	Burden VA (Ohms)	Lead Ext. Feet (Meters)	Thermal Rating Factor (@ 30°C)	UL File Cert #	CSA File Cert #	Leads Type	Weight (lb)
7020-01036-0	50:5	±2%	1.5 (0.06)	4 (1.2)	1.3	E175133	Pending	16AWG, 24" UL Style 3173	1.5
7020-01037-0	75:5	±2%	3.0 (0.12)	10 (3.0)	1.3				
7020-01038-0	100:5	±1%	3.0 (0.12)	10 (3.0)	1.3				
7020-01039-0	150:5	±1%	6.0 (0.24)	20 (6.1)	1.3				
7020-01040-0	200:5	±1%	8.0 (0.32)	30 (9.1)	1.3				
7020-01041-0	250:5	±1%	10.0 (0.40)	40 (12.2)	1.3				
7020-01123-0	300:5	±1%	12.5 (0.50)	50 (15.2)	1.0	E466945	260320	1.0	
7020-01124-0	400:5	±1%	12.5 (0.50)	50 (15.2)	1.0				
7020-01125-0	500:5	±1%	20.0 (0.80)	80 (24.4)	1.0				
7020-01042-0	600:5	±1%	10.0 (0.40)	40 (12.2)	1.0	E228202	223647	16AWG, 24" UL Style 1015	1.5
7020-01043-0	750:5	±1%	10.0 (0.40)	40 (12.2)	1.0				
7020-01044-0	1000:5	±1%	10.0 (0.40)	40 (12.2)	1.0				
7020-01045-0	1500:5	±1%	12.5 (0.50)	50 (15.2)	1.0				
7020-01046-0	2000:5	±1%	15.0 (0.60)	60 (18.3)	1.0				

See [www.murata-ps.com/dpm-availability](http://www.murata-ps.com/dpm-availability) for model-specific availability.

**MECHANICAL SPECIFICATIONS**

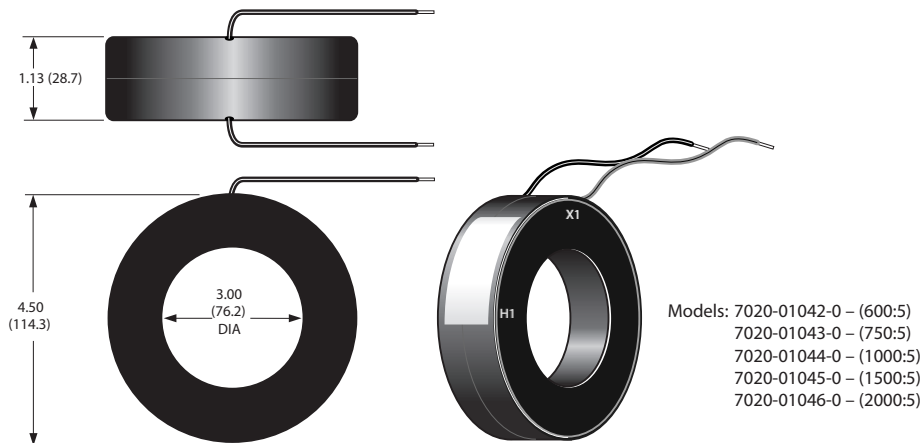
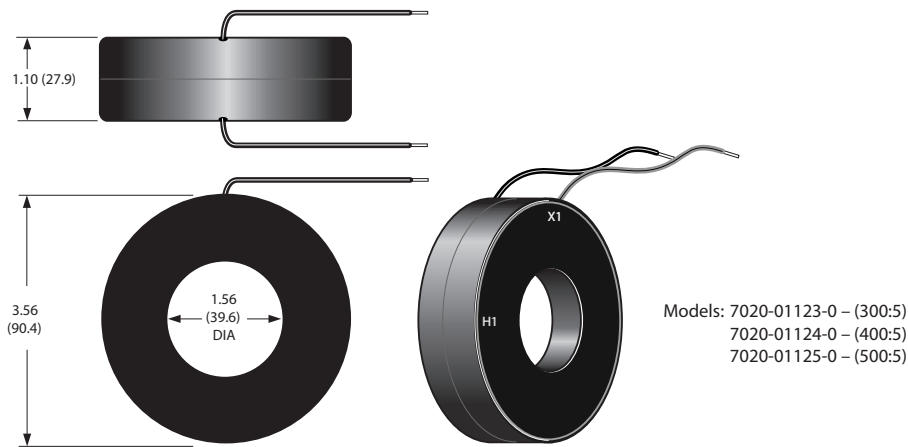
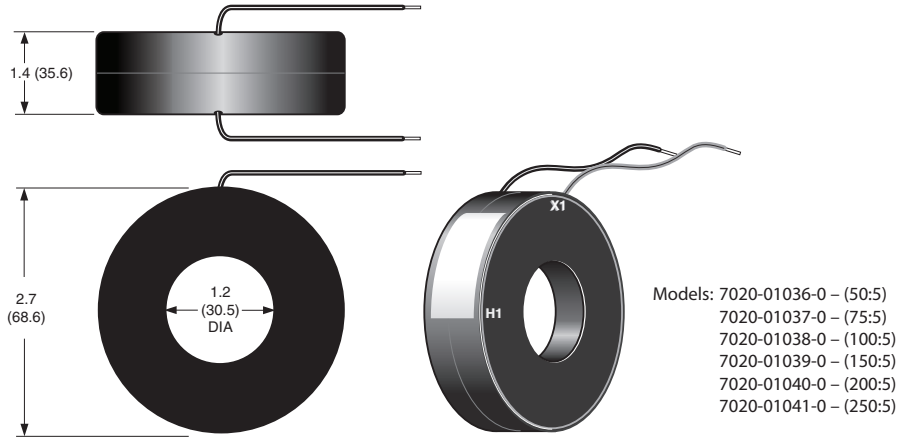

**NOTES**

---

Murata Power Solutions, Inc.  
ISO 9001 and 14001 REGISTERED



**This product is subject to the following operating requirements and the Life and Safety Critical Application Sales Policy:**  
Refer to: <http://www.murata-ps.com/requirements/>

Murata Power Solutions, Inc. makes no representation that the use of its products in the circuits described herein, or the use of other technical information contained herein, will not infringe upon existing or future patent rights. The descriptions contained herein do not imply the granting of licenses to make, use, or sell equipment constructed in accordance therewith. Specifications are subject to change without notice. © 2018 Murata Power Solutions, Inc.

# Mouser Electronics

Authorized Distributor

Click to View Pricing, Inventory, Delivery & Lifecycle Information:

[Murata:](#)

[39-3681407](#) [39-3681408](#) [39-3681409](#) [7020-01036-0](#) [7020-01037-0](#) [7020-01038-0](#) [7020-01039-0](#) [7020-01040-0](#)  
[7020-01041-0](#) [7020-01042-0](#) [7020-01043-0](#) [7020-01044-0](#) [7020-01045-0](#) [7020-01046-0](#)