

NPI-19 Series

Medium Pressure Sensors



Applications

- Process control systems
- Hydraulic systems and valves
- Biomedical instruments
- Refrigeration and HVAC controls
- Appliances and consumer electronics
- Ship and marine systems
- Aircraft and avionic systems

Features

- Solid state, high reliability
- 316L stainless steel, ISO sensor design
- $\pm 0.5\%$ static accuracy
- Temperature compensated 32°F to 158°F (0°C to 70°C)
- High sensitivity, 100 mV FSO with 1.0 mA excitation
- Linearity 0.1% FSO typical
- Four standard ranges: 0 to 15 psig (0 to 1 bar), 0 to 250 psig (0 to 17 bar) available in gauge or absolute
- Voltage driven ranges: 15, 30, 50, 100, 200 and 300 psi (1, 2, 3, 7, 14 and 20 bar) gauge and absolute
- Standard configurations include:
 - _ 1/2 in-20 UNF threaded male port with 1.0 in (25 mm) flange
 - _ 0.74 in (18.8 mm) diameter x 0.28 in (7 mm) long cylinder with o-ring seals
 - _ 1/4 in-18 NPT male port with 7/8 in (22 mm) flange
 - _ 1/8 in-27 NPT male port with 7/8 in (22 mm) flange
- Custom configurations and other pressure ranges available. Please consult the factory.

NPI-19 Series Specifications

Current Driven Medium Pressure, Media Isolated Pressure Sensor

The NovaSensor NPI Series incorporates state-of-the-art IsoSensor technology, which gives the OEM user the best in price and performance. They are designed to operate in hostile environments and yet give the outstanding sensitivity, linearity, and hysteresis of a silicon sensor. The piezoresistive sensor chip is housed in a fluid filled cylindrical cavity and isolated from measured media by a stainless steel diaphragm and body. As with all NovaSensor silicon sensors, the NPI Series employs SenStable[®] processing technology, providing excellent output stability.

The modular design allows for a variety of pressure port modules, which are hermetically welded to the sensor header module. Standard types A, B, H, and J are shown inside.

For compensation of temperature effects, a complete resistor network is supplied on a hybrid ceramic substrate. The IsoSensor design minimizes temperature errors to provide a maximum offset error of 0.75% FSO over the 32°F to 158°F (0°C to 70°C) compensated range.

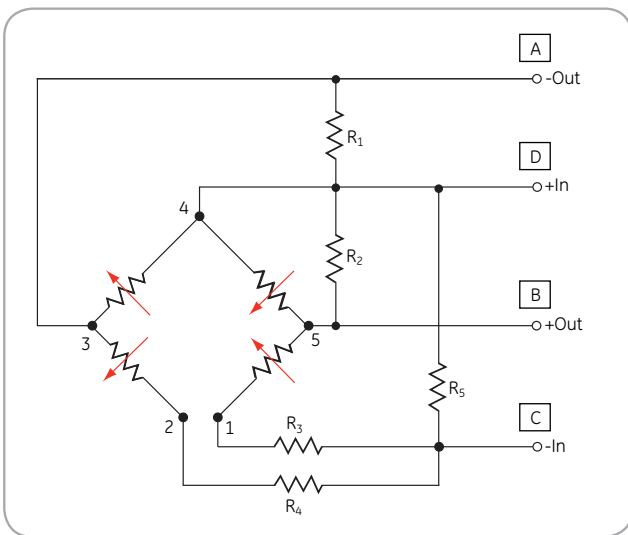

NPI-19 Series Constant Current schematic diagram

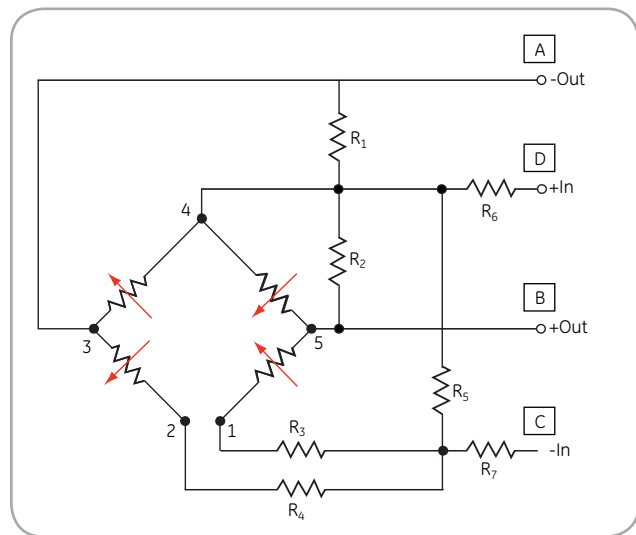

NPI-19 Series Constant Voltage schematic diagram

NPI-19 Series Specifications

Parameter	Value	Notes
General⁽⁶⁾		
Pressure Range	0 to 100 kPa	0 to 15 psi (0 to 1 bar)
NPI 19	0 to 200 kPa 0 to 700 kPa 0 to 1700 kPa	0 to 30 psi (0 to 2.07 bar) 0 to 100 psi (0 to 6.89 bar) 0 to 250 psi (0 to 17.24 bar)
NPI-19VC	0 to 103.4 kPa 0 to 206.8 kPa 0 to 344.7 kPa 0 to 689.4 kPa 0 to 1379 kPa 0 to 2068 kPa	0 to 15 psi (0 to 1 bar) 0 to 30 psi (0 to 2.07 bar) 0 to 50 psi (0 to 3.44 bar) 0 to 100 psi (0 to 6.89 bar) 0 to 200 psi (0 to 14 bar) 0 to 300 psi (0 to 21 bar)
Maximum Overpressure	2x	rated pressure
Electrical @ 77°F (25°C) unless otherwise stated		
Input Excitation		
NPI-19	1.0 mA	1.5mA maximum
NPI-19VC	10 VDC	1.5 VDC maximum
Insulation Resistance	10 ⁸ Ω	@50 VDC
Input Impedance		
NPI-19	4,000 Ω	± 20%
NPI-19VC	4,000 Ω	
Output Impedance	5,000 Ω	± 20%
Bridge Impedance	5,000 Ω	± 20%
Environmental		
Temperature Range		
Operating ⁽⁶⁾	-40°F to 257°F	(-40°C to 125°C)
Compensation	32°F to 158°F 10 gRMs	(0°C to 70°C) 20 to 2000 Hz
Shock	100 g	11 milliseconds
Life (Dynamic Pressure Cycle)	1 x 10 ⁶ Cycles	
Mechanical		
Weight	0.02 lb (10 g) 0.1 lb (45 g)	NPI-19A-XXX NPI-19B/H/J-XXX
Media Compatibility	All corrosive media compatible with 316 L stainless steel	
Case and Diaphragm Material	316L stainless steel	
Recommended O-Ring		
Type A	0.66 in x 0.039 (16.76 mm x 1 mm) diameter	
Type B	2-013 per ISO 3601/1	

Parameter	Units	Min.	Typical	Max.	Notes
Performance Parameters⁽⁵⁾ Compensated⁽¹⁾					
Offset	mV	-2	1	2	mV
FSO Output					
NPI-19	mV	70	100	130	2
NPI-19VC	mV	99	100	101	2
Linearity	%FSO	-0.25	0.1	0.25	3
Hysteresis and Repeatability	%FSO	-0.05	0.01	0.05	
Thermal Accuracy of Offset					
NPI-19	%FSO	-0.75	0.2	0.75	4
NPI-19VC	%FSO	-1.0	0.2	1.0	4
Thermal Accuracy of FSO					
	%FSO	-0.75	0.2	0.75	4
Thermal Hysteresis					
	%FSO	-0.2	0.1	0.2	5
Short-Term Stability of Offset	μV/V				6
Short-Term Stability of FSO	μV/V		5		6
Long-Term Stability of Offset	%FSO		0.1		7
Long-Term Stability of FSO	%FSO		0.1		7

1. Performance with offset, thermal accuracy of offset, and thermal accuracy of FSO compensation resistors.
2. FSO with 1.0 mA input excitation, 10 VDC for NPI-19VC.
3. Linearity by best fit straight line.
4. 2°F to 158°F (0°C to 70°C) with reference to 77°F (25°C).
5. 32°F to 158°F (0 to 70°C), by design.
6. Normalized offset/bridge voltage— 100 hours, typical value, not tested in production.
7. 1 year, typical value, not tested in production.
8. Consult factory for vacuum applications.

NPI-19 Series Specifications

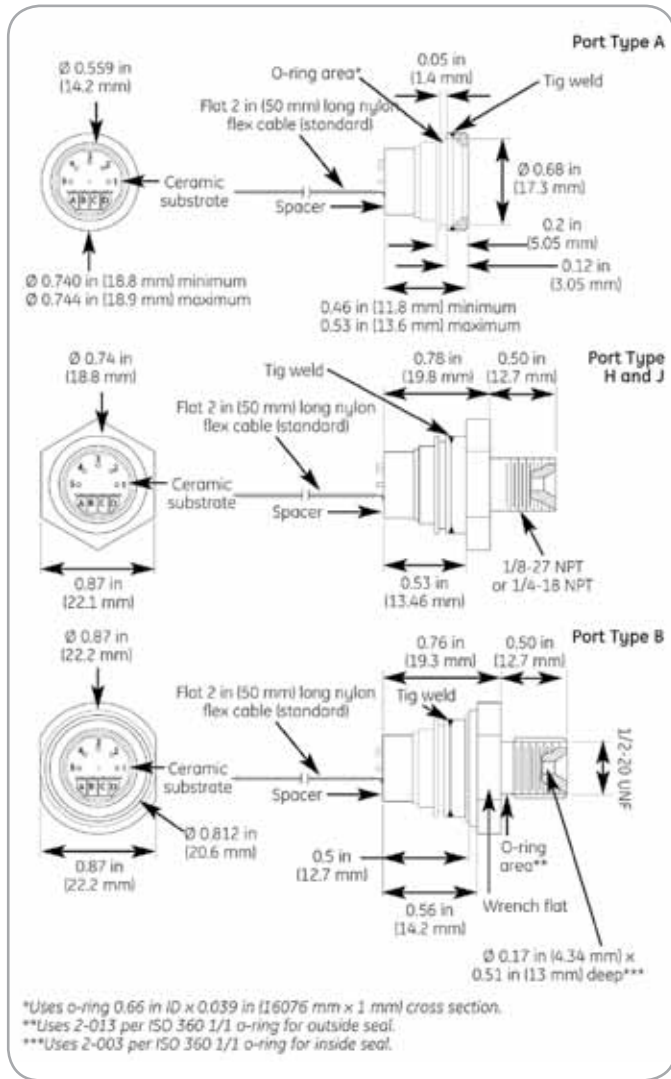

NPI-19 Series dimensions

NPI-19 NovaSensor Pressure Type (ISO Sensor)

Code Pressure Port Type

- A No port, o-ring seal
- B 1/2-20 UNF
- H 1/4-18 NPT
- J 1/8-27 NPT

Code Pressure Ranges

- 101 100 kPa, 1 mA
- 201 200 kPa, 1 mA
- 701 700 kPa, 1 mA
- 172 1700 kPa, 1mA
- 015 015 psi (1 bar), 10 V
- 030 30 psi (2.07 bar), 10 V
- 050 50 psi (3.44 bar), 10 V
- 100 100 psi (6.89 bar), 10 V
- 200 200 psi (14 bar), 10 V
- 300 300 psi (21 bar), 10 V

Code Description

- A Absolute
- G Gauge

Code Voltage

- H Constant Current Supply (1.0 mA)
- V Constant Voltage Supply (10 VDC)

NPI-19 - ____ - ____ - ____ - ____ Typical model number

Mouser Electronics

Authorized Distributor

Click to View Pricing, Inventory, Delivery & Lifecycle Information:

Amphenol:

[NPI-19A-200AV](#) [NPI-19B-015GV](#) [NPI-19B-015AV](#) [NPI-19H-201AH](#) [NPI-19A-015GV](#) [NPI-19A-015AV](#) [NPI-19A-200GAV](#) [NPI-19H-200AV](#) [NPI-19H-200GV](#) [NPI-19J-200GV](#) [NPI-19B-100GV](#) [NPI-19A-100GV](#) [NPI-19A-100AV](#) [NPI-19B-100AV](#) [NPI-19H-030GV](#) [NPI-19J-030AV](#) [NPI-19H-030AV](#) [NPI-19B-200AV](#) [NPI-19A-200GV](#) [NPI-19-200GV](#) [NPI-19B-201AH](#) [NPI-19A-201AH](#) [NPI-19A-201GH](#) [NPI-19J-300AV](#) [NPI-19J-201AH](#) [NPI-19J-030GV](#) [NPI-19H-300AV](#) [NPI-19J-300GV](#) [NPI-19H-300GV](#) [NPI-19B-701GH](#) [NPI-19A-701GH](#) [NPI-19J-200AV](#) [NPI-19B-701AH](#) [NPI-19A-701AH](#) [NPI-19B-030GV](#) [NPI-19A-030AV](#) [NPI-19H-015GV](#) [NPI-19J-015GV](#) [NPI-19J-015AV](#) [NPI-19H-015AV](#) [NPI-19J-050AV](#) [NPI-19A-101AH](#) [NPI-19B-101AH](#) [NPI-19A-101GH](#) [NPI-19B-101GH](#) [NPI-19J-201GH](#) [NPI-19H-201GH](#) [NPI-19H-172GH](#) [NPI-19A-030GV](#) [NPI-19A-300AV](#) [NPI-19B-300AV](#) [NPI-19A-300GV](#) [NPI-19B-030AV](#) [NPI-19H-050GV](#) [NPI-19J-050GV](#) [NPI-19H-050AV](#) [NPI-19H-101GH](#) [NPI-19J-101GH](#) [NPI-19B-201GH](#) [NPI-19J-100GV](#) [NPI-19-300GV](#) [NPI-19H-101AH](#) [NPI-19J-101AH](#) [NPI-19H-100GV](#) [NPI-19H-100AV](#) [NPI-19J-100AV](#) [NPI-19J-701GH](#) [NPI-19A-172AH](#) [NPI-19B-172AH](#) [NPI-19A-172GH](#) [NPI-19B-172GH](#) [NPI-19H-701AH](#) [NPI-19J-701AH](#) [NPI-19H-701GH](#) [NPI-19-050GV](#) [NPI-19H-172AH](#) [NPI-19J-172AH](#) [NPI-19A-050GV](#) [NPI-19B-050AV](#) [NPI-19A-050AV](#) [NPI-19J-172GH](#) [NPI-19B-300GV](#) [NPI-19B-050GV](#) [NPI-19B-200GV](#)