

# Si3220/25 Dual ProSLIC™

**GLOBALLY PROGRAMMABLE DUAL-CHANNEL CMOS SLIC/CODEC WITH RINGING AND SUBSCRIBER LINE DIAGNOSTICS**

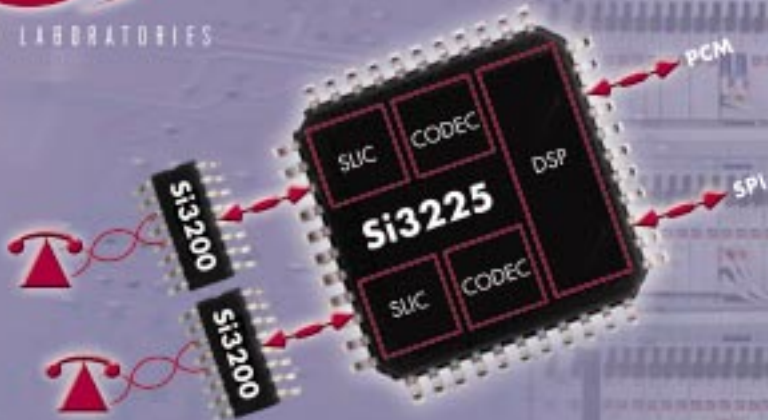

## PRODUCT DESCRIPTION

The Dual ProSLIC is a low power CMOS solution that integrates two SLICs and two codecs into a tiny footprint to provide the smallest and lowest cost dual-channel analog telephone interface. Fully programmable parameters allow global compliance using a single hardware solution and on-chip functions such as DTMF generation/decoding, FSK caller ID generation, and modem tone detection help eliminate external DSP requirements. Integrated test and line monitoring allows remote subscriber loop and line card diagnostics without centralized test equipment. The Si3220 provides programmable internal ringing generation for space-constrained CPE applications, and the Si3225 includes internal ringing relay drivers and ring trip detection to minimize external components in traditional access applications. The Si3220 and Si3225 operate from a single 3.3 V or 5 V supply and interface directly to standard PCM/SPI or GCI digital interfaces; all high voltage functions are performed using the Si3200 linefeed interface IC. The Si3220 and Si3225 are packaged in a 64-pin TQFP, and the Si3200 is packaged in a thermally-enhanced 16-pin SOIC.

## DUAL ProSLIC BLOCK DIAGRAM

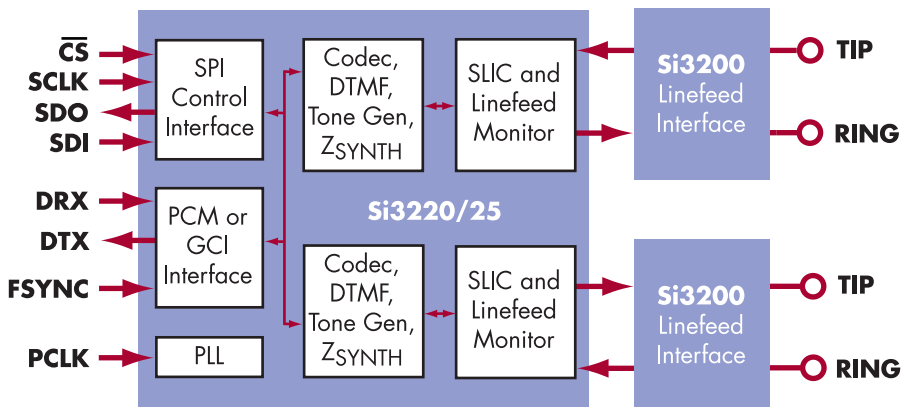

## FEATURES

- Performs all battery, overvoltage, ringing, supervision, coding, hybrid, and test (BORSCHT) functions per LSSGR and ITU standards
- Ideal for applications up to 18,000 feet
- Software programmable parameters for global compliance with one hardware design:
  - Constant current loop feed (18–45 mA)
  - Two-wire AC impedance
  - Transhybrid balance
  - Ringing frequency, amplitude, cadence
  - Loop closure and ring trip thresholds
  - Ground key detection threshold
- Low standby power consumption: <50 mW
- Integrated subscriber line diagnostics and multiple analog/digital loopback test modes
- Internal ringing up to 65V<sub>RMS</sub> (Si3220)
- Programmable ringing relay control and ring trip detection for centralized ringing architectures (Si3225)
- Loop start and ground start support
- Automatic dual battery switching
- DTMF generation and decoding
- Modem/fax tone detection
- FSK (caller ID) tone generation
- 12/16 kHz pulse metering (Si3220)
- PCM/SPI or GCI digital interfaces

## APPLICATIONS

- CO/DLC line cards
- PBX/key telephone systems
- Cable telephony systems
- Voice over IP/Voice over DSL systems
- Pair gain remote terminals

## PRODUCT BRIEF

THE DUAL PROSLIC IS THE SMALLEST  
SLIC/CODEC SOLUTION FOR  
SHORT AND LONG LOOP  
TELEPHONY APPLICATIONS



**GLOBALLY PROGRAMMABLE,  
HIGHLY INTEGRATED**

**Unmatched Size and Integration**

The Dual ProSLIC's tiny footprint requires up to 50% less board space and 50% fewer discrete components than typical SLIC/codec solutions.

**Globally Programmable**

All operating parameters are software programmable, offering the ability to design a single hardware solution for global compliance.

**Eliminates Truck Rolls**

Integrated subscriber line diagnostics help eliminate costly truck rolls by allowing remote testing of the subscriber loop and line card circuitry without centralized test equipment or test relays.

**System Partitioning for Low Cost**

Unlike conventional solutions that use bipolar or BiCMOS SLIC process technology, the Si3220 and Si3225 implement both SLIC and codec in a low voltage CMOS IC and the Si3200 linefeed interface chip (LFIC) handles the high voltage telephone line interface duties in a tiny, low cost device. The result is an optimally partitioned system that provides the lowest total solution cost.

**Globally Programmable for Short and Long Loop Applications**

**Si3220:**

Internal ringing for short loop and CPE applications



**Si3225:**

Addresses traditional access applications using centralized ringing generator

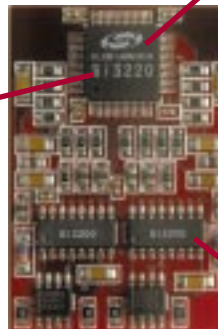

(Actual Size)  
< 1 in<sup>2</sup> per channel

**Si3220/Si3225 Dual ProSLIC:**

- Dual SLICs and codecs
- Software programmable
- On-chip DTMF & caller ID
- Subscriber line diagnostics
- 10 x 10 mm 64 pin TQFP
- Low power

**Si3200 Linefeed Interface Chip (LFIC):**

- Low power
- Supports 100 V ringing
- Power-enhanced 16 pin SOIC

ProSLIC Family Feature Summary					
Feature	Si3210	Si3211/ Si3212	Si3220	Si3225	Si3232
Number of channels	single	single	dual	dual	dual
Integrated SLIC and codec	✓	✓	✓	✓	no codecs
Internal ringing to 65V <sub>RMS</sub>	✓	✓	✓		✓
External ringing support				✓	
On-Chip DC/DC converter	✓				
On-Chip DTMF decoder	✓	Si3211	✓	✓	
Subscriber line diagnostics			✓	✓	✓*

\* Full line card diagnostics suite requires interaction from external codec.

**CONTACT INFORMATION**



SILICON LABORATORIES

**Silicon Laboratories Inc.**  
4635 Boston Lane • Austin, TX 78735  
**Toll Free:** (877) 444-3032  
**Email:** ProSLICinfo@silabs.com  
**Web site:** www.silabs.com

*ProSLIC, Silicon Laboratories, and the Silicon Laboratories logo are trademarks of Silicon Laboratories Inc.*  
PB:Si3220/25; MM, 5,000, Oct 01, Rev B

**ORDERING INFORMATION**

Product	Description
Si3220-KQ	Dual ProSLIC w/ Internal Ringing & Line Diagnostics, 0 to 70°C
Si3220-BQ	Dual ProSLIC w/ Internal Ringing & Line Diagnostics, -40 to 85°C
Si3225-KQ	Dual ProSLIC w/ External Ringing & Line Diagnostics, 0 to 70°C
Si3225-BQ	Dual ProSLIC w/ External Ringing & Line Diagnostics, -40 to 85°C
Si3232-KQ	Dual SLICs w/Internal Ringing & Line Diagnostics, 0 to 70°C
Si3232-BQ	Dual SLICs w/Internal Ringing & Line Diagnostics, -40 to 85°C
Si3200-KS	Single Channel ProSLIC Linefeed Interface, 0 to 70°C
Si3200-BS	Single Channel ProSLIC Linefeed Interface, -40 to 85°C

**Evaluation Boards**

Si3220PPT-EVB	Dual Channel Evaluation Board for Si3220 + Si3200
Si3225PPT-EVB	Dual Channel Evaluation Board for Si3225 + Si3200
Si3232PPT-EVB	Dual Channel Evaluation Board for Si3232 + Si3200