

High Voltage Ceramic Capacitors (DC250V-6.3kV)

HIGH VOLTAGE CERAMIC CAPACITORS

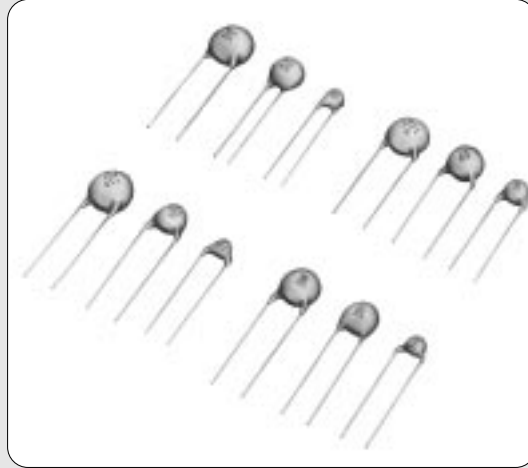

*Innovator
in Electronics*

Murata
Manufacturing Co., Ltd.

Cat.No.C84E-8

CONTENTS

Part Numbering	2
1 DES Series (125 deg. C Guaranteed/Low-dissipation Factor/DC500V-1kV)	3
● Specifications and Test Methods	5
2 DEH Series (125 deg. C Guaranteed/Low-dissipation Factor/DC250V-3.15kV)	7
● Specifications and Test Methods	10
3 DEA Series (125 deg. C Guaranteed/Class 1/DC1k-3.15kV)	12
● Specifications and Test Methods	15
4 DEB Series (Class 2/DC1k-3.15kV)	17
● Specifications and Test Methods	20
5 DEC Series (Class 1, 2/DC6.3kV)	22
● Specifications and Test Methods	24
Characteristics Data (Typical Example)	26
Packaging	27
⚠Caution	29
Notice / ISO9000 Certifications	36

1

2

3

4

5

● Part Numbering

High Voltage Ceramic Capacitors (250V-6.3kV)

(Part Number)

DE	B	B3	3A	102	K	N2	A
①	②	③	④	⑤	⑥	⑦	⑧

① Product ID

Product ID	
DE	High Voltage (250V - 6.3kV) / Safety Standard Recognized Ceramic Capacitors

② Series Category

Code	Outline	Contents
A	High Voltage	Class1 (char. SL) DC1-3.15kV Rated
B		Class 2 DC1-3.15kV Rated
C		Class 1, 2 DC6.3kV Rated
H		High Temperature Guaranteed, Low-dissipation Factor (char. R, C)
S		High Temperature Guaranteed, Low-dissipation Factor (char. D)

First three digits (①Product ID and ②Series Category) express "Series Name".

③ Temperature Characteristics

Code	Temperature Characteristics	Cap. Change or Temp. Coeff.	Temperature Range
B3	B	±10%	-25 to +85°C
E3	E	+20%, -55%	
F3	F	+30%, -80%	
C3	C	±20%	-25 to +85°C
		+15%, -30%	+85 to +125°C
R3	R	±15%	-25 to +85°C
		+15%, -30%	+85 to +125°C
D3	D	+20%, -30%	-25 to +125°C
1X	SL	+350 to -1000ppm/°C	+20 to +85°C

④ Rated Voltage

Code	Rated Voltage
2E	DC250V
2H	DC500V
3A	DC1kV
3D	DC2kV
3F	DC3.15kV
3J	DC6.3kV

⑤ Capacitance

Expressed by three figures. The unit is pico-farad(pF). The first and second figures are significant digits, and the third figure expresses the number of zeros which follow the two numbers. If there is a decimal point, it is expressed by the capital letter "R". In this case, all figures are significant digits.

⑥ Capacitance Tolerance

Code	Capacitance Tolerance
J	±5%
K	±10%
Z	+80%, -20%

⑦ Lead Style

Code	Lead Style	Dimensions(mm)		
		Lead Spacing	Lead Diameter	Pitch of Components
A2	Vertical Crimp Long	5	ø0.6±0.05	-
A3		7.5		
A4		10		
B2, J2	Vertical Crimp Short	5	ø0.6±0.05	-
B3, J3		7.5		
B4		10		
C1	Straight Long	5	ø0.5±0.05	-
C3		7.5	ø0.6±0.05	
C4		10	ø0.5±0.05	
CD		7.5	ø0.5±0.05	
D1	Straight Short	5	ø0.5±0.05	-
D3		7.5	ø0.6±0.05	
DD		7.5	ø0.5±0.05	
N2	Vertical Crimp Taping	5	ø0.6±0.05	12.7
N3		7.5		15
N7		7.5		30
P2	Straight Taping	5	ø0.6±0.05	12.7
P3		7.5		15

⑧ Packaging

Code	Packaging
A	Ammo Pack
B	Bulk

High Voltage Ceramic Capacitors (DC250V-6.3kV)



DES Series (125 deg. C Guaranteed/Low-dissipation Factor/DC500V-1kV)

■ Features

1. Low dissipation factor series which can be used for power supplies with an increased switching frequency.
2. The allowable power in the 100 to 300kHz band is improved to approximately one-and-a-half times that of DEH series while remaining the same size.
3. Operating temperature range is guaranteed up to 125 degree C.
4. Coated with flame-retardant epoxy resin (equivalent to UL94V-0 standards).
5. We eliminated lead (Pb) from plating lead wires and inner-solder.
6. Taping available for automatic insertion.

■ Applications

Ideal for use on high frequency pulse circuits such as snubber circuits for switching power supplies.

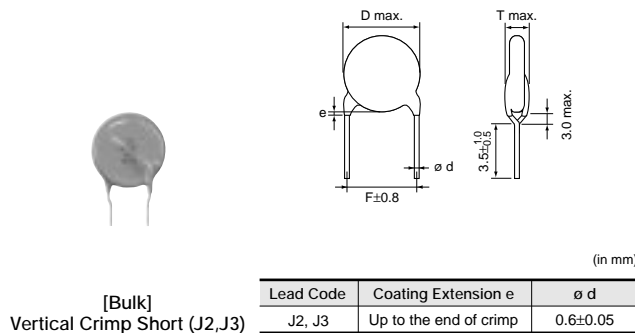
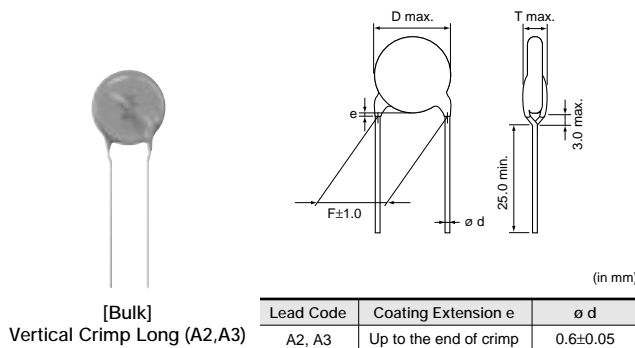

■ Marking

Nominal body diameter	Rated Voltage	
	DC500V	DC1KV
ø6mm		
ø7-9mm		
ø10-17mm		
Series Code	Abbreviation (S)	
Temperature Characteristic	Marked with code	
Nominal Capacitance	Marked with 3 figures	
Capacitance Tolerance	Marked with code (omitted for nominal body diameter ø6mm)	
Rated Voltage	Marked with code (omitted for DC500V)	
Manufacturer's Identification	Marked with (omitted for nominal body diameter ø9mm and under)	
Manufactured Date Code	Abbreviation	

D Characteristics

Part Number	DC Rated Voltage (Vdc)	Capacitance (pF)	Body Dia. D (mm)	Lead Spacing F (mm)	Body Thickness T (mm)	Lead Package Long Bulk	Lead Package Short Bulk	Lead Package Taping
DESD32H101K□□□	500	100 +10,-10%	6	5.0	4.0	A2B	J2B	N2A
DESD32H151K□□□	500	150 +10,-10%	6	5.0	4.0	A2B	J2B	N2A
DESD32H221K□□□	500	220 +10,-10%	6	5.0	4.0	A2B	J2B	N2A
DESD32H331K□□□	500	330 +10,-10%	6	5.0	4.0	A2B	J2B	N2A
DESD32H471K□□□	500	470 +10,-10%	6	5.0	4.0	A2B	J2B	N2A
DESD32H681K□□□	500	680 +10,-10%	6	5.0	4.0	A2B	J2B	N2A
DESD32H102K□□□	500	1000 +10,-10%	8	5.0	4.0	A2B	J2B	N2A
DESD32H152K□□□	500	1500 +10,-10%	9	5.0	4.0	A2B	J2B	N2A
DESD32H222K□□□	500	2200 +10,-10%	10	5.0	4.0	A2B	J2B	N2A
DESD32H332K□□□	500	3300 +10,-10%	12	7.5	4.0	A3B	J3B	N3A
DESD32H472K□□□	500	4700 +10,-10%	14	7.5	4.0	A3B	J3B	N7A
DESD33A101K□□□	1000	100 +10,-10%	6	5.0	4.5	A2B	J2B	N2A
DESD33A151K□□□	1000	150 +10,-10%	6	5.0	4.5	A2B	J2B	N2A
DESD33A221K□□□	1000	220 +10,-10%	6	5.0	4.5	A2B	J2B	N2A
DESD33A331K□□□	1000	330 +10,-10%	6	5.0	4.5	A2B	J2B	N2A
DESD33A471K□□□	1000	470 +10,-10%	7	5.0	4.5	A2B	J2B	N2A
DESD33A681K□□□	1000	680 +10,-10%	8	5.0	4.5	A2B	J2B	N2A
DESD33A102K□□□	1000	1000 +10,-10%	9	5.0	4.5	A2B	J2B	N2A
DESD33A152K□□□	1000	1500 +10,-10%	10	5.0	4.5	A2B	J2B	N2A
DESD33A222K□□□	1000	2200 +10,-10%	12	7.5	4.5	A3B	J3B	N3A
DESD33A332K□□□	1000	3300 +10,-10%	14	7.5	4.5	A3B	J3B	N7A
DESD33A472K□□□	1000	4700 +10,-10%	17	7.5	4.5	A3B	J3B	N7A

Three blank columns are filled with the lead and packaging codes. Please refer to the 3 columns on the right for the appropriate code.

Specifications and Test Methods

No.	Item		Specifications	Testing Method												
1	Operating Temperature Range		-25 to +125°C													
2	Appearance and Dimensions		No marked defect on appearance form and dimensions are within specified range.	The capacitor should be visually inspected for evidence of defect. Dimensions should be measured with slide calipers.												
3	Marking		To be easily legible.	The capacitor should be visually inspected.												
4	Dielectric Strength	Between Lead Wires	No failure.	The capacitor should not be damaged when DC voltage of 200% of the rated voltage (DC1kV) or DC voltage of 250% of the rated voltage (DC500V) is applied between the lead wires for 1 to 5 sec. (Charge/Discharge current \leq 50mA.)												
		Body Insulation	No failure.	The capacitor is placed in the container with metal balls of diameter 1mm so that each lead wire, shortcircuited, is kept about 2mm off the metal balls as shown in the figure at right, and AC1250V (r.m.s.) <50/60Hz> is applied for 1 to 5 sec. between capacitor lead wires and metal balls. (Charge/Discharge current \leq 50mA.)												
5	Insulation Resistance (I.R.)	Between Lead Wires	10000M Ω min.	The insulation resistance should be measured with DC500 \pm 50V within 60 \pm 5 sec. of charging.												
6	Capacitance		Within specified tolerance.	The capacitance should be measured at 20°C with 1 \pm 0.2kHz and AC5V(r.m.s.) max.												
7	Dissipation Factor (D.F.)		0.3% max.	The dissipation factor should be measured at 20°C with 1 \pm 0.2kHz and AC5V(r.m.s.) max.												
8	Temperature Characteristics		Within +20/-30% (Temp. range : -25 to +125°C)	The capacitance measurement should be made at each step specified in Table.												
			Pre-treatment : Capacitor should be stored at 125 \pm 3°C for 1 hr., then placed at *room condition for 24 \pm 2 hrs. before measurements.													
			<table border="1"> <thead> <tr> <th>Step</th> <th>1</th> <th>2</th> <th>3</th> <th>4</th> <th>5</th> </tr> </thead> <tbody> <tr> <td>Temp.(°C)</td> <td>20\pm2</td> <td>-25\pm3</td> <td>20\pm2</td> <td>125\pm2</td> <td>20\pm2</td> </tr> </tbody> </table>	Step	1	2	3	4	5	Temp.(°C)	20 \pm 2	-25 \pm 3	20 \pm 2	125 \pm 2	20 \pm 2	
Step	1	2	3	4	5											
Temp.(°C)	20 \pm 2	-25 \pm 3	20 \pm 2	125 \pm 2	20 \pm 2											
9	Strength of Lead	Pull	Lead wire should not be cut off. Capacitor should not be broken.	As shown in the figure at right, fix the body of the capacitor and apply a tensile weight gradually to each lead wire in the radial direction of the capacitor up to 10N and keep it for 10 \pm 1 sec.												
		Bending		Each lead wire should be subjected to 5N of weight and bent 90° at the point of egress, in one direction, then returned to its original position and bent 90° in the opposite direction at the rate of one bend in 2 to 3 sec.												
10	Vibration Resistance	Appearance	No marked defect.	The capacitor should be firmly soldered to the supporting lead wire and vibrated at a frequency range of 10 to 55Hz, 1.5mm in total amplitude, with about a 1 minute rate of vibration change from 10Hz to 55Hz and back to 10Hz. Apply for a total of 6 hrs., 2 hrs. each in 3 mutually perpendicular directions.												
		Capacitance	Within specified tolerance.													
		D.F.	0.3% max.													
11	Solderability of Leads		Lead wire should be soldered with uniform coating on the axial direction over 3/4 of the circumferential direction.	The lead wire of a capacitor should be dipped into a ethanol solution of 25wt% rosin and then into molten solder of 235 \pm 5°C for 2 \pm 0.5 sec. In both cases the depth of dipping is up to about 1.5 to 2mm from the root of lead wires.												
12	Soldering Effect	Appearance	No marked defect.	The lead wire should be immersed into the melted solder of 350 \pm 10°C up to about 1.5 to 2mm from the main body for 3.5 \pm 0.5 sec. Pre-treatment : Capacitor should be stored at 125 \pm 3°C for 1 hr., then placed at *room condition for 24 \pm 2 hrs. before initial measurements. Post-treatment : Capacitor should be stored for 24 \pm 2 hrs. at *room condition.												
		Capacitance Change	Within \pm 10%													
		Dielectric Strength (Between Lead Wires)	Per item 4.													

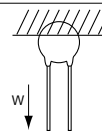
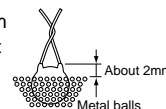

* "room condition" Temperature: 15 to 35°C, Relative humidity: 45 to 75%, Atmospheric pressure: 86 to 106kPa

Continued on the following page.

Specifications and Test Methods

Continued from the preceding page.

No.	Item	Specifications	Testing Method																
13	Temperature Cycle	Appearance	No marked defect.	The capacitor should be subjected to 5 temperature cycles. <Temperature cycle> <table border="1" style="margin: 10px auto; border-collapse: collapse;"> <thead> <tr> <th style="font-size: small;">Step</th> <th style="font-size: small;">Temperature(°C)</th> <th style="font-size: small;">Time(min)</th> </tr> </thead> <tbody> <tr> <td style="text-align: center;">1</td> <td style="text-align: center;">-25±3</td> <td style="text-align: center;">30</td> </tr> <tr> <td style="text-align: center;">2</td> <td style="text-align: center;">Room Temp.</td> <td style="text-align: center;">3</td> </tr> <tr> <td style="text-align: center;">3</td> <td style="text-align: center;">125±3</td> <td style="text-align: center;">30</td> </tr> <tr> <td style="text-align: center;">4</td> <td style="text-align: center;">Room Temp.</td> <td style="text-align: center;">3</td> </tr> </tbody> </table> Cycle time : 5 cycle Pre-treatment : Capacitor should be stored at 125±3°C for 1 hr., then placed at *room condition for 24±2 hrs. before initial measurements. Post-treatment : Capacitor should be stored for 24±2 hrs. at *room condition.	Step	Temperature(°C)	Time(min)	1	-25±3	30	2	Room Temp.	3	3	125±3	30	4	Room Temp.	3
		Step	Temperature(°C)		Time(min)														
		1	-25±3		30														
		2	Room Temp.		3														
		3	125±3		30														
4	Room Temp.	3																	
Capacitance Change	Within ±10%																		
D.F.	0.4% max.																		
I.R.	1000MΩ min.																		
Dielectric Strength (Between Lead Wires)	Per item 4.																		
14	Humidity (Under Steady State)	Appearance	No marked defect.	Set the capacitor for 500 +24/-0 hrs. at 40±2°C in 90 to 95% relative humidity. Pre-treatment : Capacitor should be stored at 125±3°C for 1 hr., then placed at *room condition for 24±2 hrs. before initial measurements. Post-treatment : Capacitor should be stored for 1 to 2 hrs. at *room condition.															
		Capacitance Change	Within ±10%																
		D.F.	0.4% max.																
		I.R.	1000MΩ min.																
15	Humidity Loading	Appearance	No marked defect.	Apply the rated voltage for 500 +24/-0 hrs. at 40±2°C in 90 to 95% relative humidity. (Charge/Discharge current ≤50mA.) Pre-treatment : Capacitor should be stored at 125±3°C for 1 hr., then placed at *room condition for 24±2 hrs. before initial measurements. Post-treatment : Capacitor should be stored for 1 to 2 hrs. at *room condition.															
		Capacitance Change	Within ±10%																
		D.F.	0.6% max.																
		I.R.	1000MΩ min.																
16	Life	Appearance	No marked defect.	Apply a DC voltage of 200% of the rated voltage (DC500V) or DC voltage of 150% of the rated voltage (DC1kV) for 1000 +48/-0 hrs. at 125±2°C with a relative humidity of 50% max. (Charge/Discharge current ≤ 50mA.) Pre-treatment : Capacitor should be stored at 125±3°C for 1 hr., then placed at *room condition for 24±2 hrs. before initial measurements. Post-treatment : Capacitor should be stored at 125±3°C for 1 hr., then placed at *room condition for 24±2 hrs.															
		Capacitance Change	Within ±10%																
		D.F.	0.4% max.																
		I.R.	2000MΩ min.																

* "room condition" Temperature: 15 to 35°C, Relative humidity: 45 to 75%, Atmospheric pressure: 86 to 106kPa

High Voltage Ceramic Capacitors (DC250V-6.3kV)

DEH Series (125 deg. C Guaranteed/Low-dissipation Factor/DC250V-3.15kV)

■ Features

1. Reduced heat dissipation permitted due to small dielectric loss of the ceramic material.
2. Operating temperature range is guaranteed up to 125 degree C.
3. Coated with flame-retardant epoxy resin (equivalent to UL94V-0 standards).
4. We eliminated lead (Pb) from plating lead wires.
5. Taping available for automatic insertion.

■ Applications

Ideal for use on high frequency pulse circuits such as a horizontal resonance circuit for CTV and snubber circuits for switching power supplies.

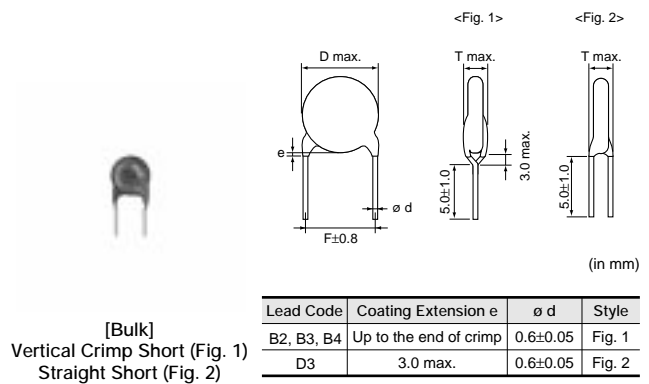
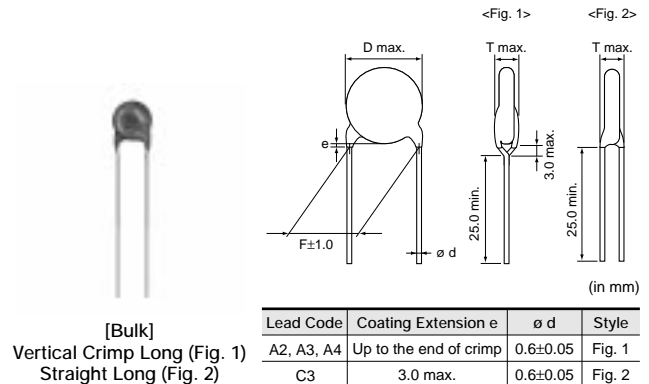

■ Marking

Rated Voltage		DC250V	DC500V	DC1-3.15kV
Nominal body diameter	Temp. Char.	R	C	R
	ø6mm			
ø7-9mm				
ø10-21mm				
High Temperature Guaranteed Code		HR		
Temperature Characteristics		Marked with code (omitted for nominal body diameter ø6mm)		
Nominal Capacitance		Marked with 3 figures		
Capacitance Tolerance		Marked with code (omitted for nominal body diameter ø6mm)		
Rated Voltage	DC250V	Marked with code (Marked with horizontal line over nominal capacitance for nominal body diameter ø6mm)		
	DC500V	Omitted		
	DC1-3.15kV	Marked with code (In case of DC3.15kV, marked with 3KV)		
Manufacturer's Identification		Marked with (omitted for nominal body diameter ø9mm and under)		
Manufactured Date Code		Abbreviation		

DC250V, R Characteristics

Part Number	DC Rated Voltage (Vdc)	Capacitance (pF)	Body Dia. D (mm)	Lead Spacing F (mm)	Body Thickness T (mm)	Lead Package Long Bulk	Lead Package Short Bulk	Lead Package Taping
DEHR32E221K□□□	250	220 +10,-10%	6	5.0	4.0	A2B	B2B	N2A
DEHR32E331K□□□	250	330 +10,-10%	6	5.0	4.0	A2B	B2B	N2A
DEHR32E471K□□□	250	470 +10,-10%	6	5.0	4.0	A2B	B2B	N2A
DEHR32E681K□□□	250	680 +10,-10%	6	5.0	4.0	A2B	B2B	N2A
DEHR32E102K□□□	250	1000 +10,-10%	6	5.0	4.0	A2B	B2B	N2A
DEHR32E152K□□□	250	1500 +10,-10%	7	5.0	4.0	A2B	B2B	N2A
DEHR32E222K□□□	250	2200 +10,-10%	8	5.0	4.0	A2B	B2B	N2A
DEHR32E332K□□□	250	3300 +10,-10%	9	5.0	4.0	A2B	B2B	N2A
DEHR32E472K□□□	250	4700 +10,-10%	10	5.0	4.0	A2B	B2B	N2A
DEHR32E682K□□□	250	6800 +10,-10%	12	5.0	4.0	A2B	B2B	N2A
DEHR32E103K□□□	250	10000 +10,-10%	12	5.0	4.0	A2B	B2B	N2A

Three blank columns are filled with the lead and packaging codes. Please refer to the 3 columns on the right for the appropriate code.

DC500V, C Characteristics

Part Number	DC Rated Voltage (Vdc)	Capacitance (pF)	Body Dia. D (mm)	Lead Spacing F (mm)	Body Thickness T (mm)	Lead Package Long Bulk	Lead Package Short Bulk	Lead Package Taping
DEHC32H331K□□□	500	330 +10,-10%	6	5.0	4.0	A2B	B2B	N2A
DEHC32H471K□□□	500	470 +10,-10%	6	5.0	4.0	A2B	B2B	N2A
DEHC32H681K□□□	500	680 +10,-10%	7	5.0	4.0	A2B	B2B	N2A
DEHC32H102K□□□	500	1000 +10,-10%	8	5.0	4.0	A2B	B2B	N2A
DEHC32H152K□□□	500	1500 +10,-10%	9	5.0	4.0	A2B	B2B	N2A
DEHC32H222K□□□	500	2200 +10,-10%	10	5.0	4.0	A2B	B2B	N2A
DEHC32H332K□□□	500	3300 +10,-10%	12	5.0	4.0	A2B	B2B	N2A
DEHC32H472K□□□	500	4700 +10,-10%	14	10.0	4.0	A4B	B4B	-

Three blank columns are filled with the lead and packaging codes. Please refer to the 3 columns on the right for the appropriate code.

DC1-3.15kV, R Characteristics

Part Number	DC Rated Voltage (Vdc)	Capacitance (pF)	Body Dia. D (mm)	Lead Spacing F (mm)	Body Thickness T (mm)	Lead Package Long Bulk	Lead Package Short Bulk	Lead Package Taping
DEHR33A221K□□□	1000	220 +10,-10%	7	5.0	4.5	A2B	B2B	N2A
DEHR33A331K□□□	1000	330 +10,-10%	7	5.0	4.5	A2B	B2B	N2A
DEHR33A471K□□□	1000	470 +10,-10%	7	5.0	4.5	A2B	B2B	N2A
DEHR33A681K□□□	1000	680 +10,-10%	8	5.0	4.5	A2B	B2B	N2A
DEHR33A102K□□□	1000	1000 +10,-10%	9	5.0	4.5	A2B	B2B	N2A
DEHR33A152K□□□	1000	1500 +10,-10%	11	5.0	4.5	A2B	B2B	N2A
DEHR33A222K□□□	1000	2200 +10,-10%	13	7.5	4.5	A3B	B3B	N3A
DEHR33A332K□□□	1000	3300 +10,-10%	15	7.5	4.5	A3B	B3B	N7A
DEHR33A472K□□□	1000	4700 +10,-10%	17	7.5	4.5	A3B	B3B	N7A
DEHR33D221K□□□	2000	220 +10,-10%	7	7.5	5.0	C3B	D3B	P3A
DEHR33D271K□□□	2000	270 +10,-10%	7	7.5	5.0	C3B	D3B	P3A
DEHR33D331K□□□	2000	330 +10,-10%	8	7.5	5.0	A3B	B3B	N3A
DEHR33D391K□□□	2000	390 +10,-10%	8	7.5	5.0	A3B	B3B	N3A
DEHR33D471K□□□	2000	470 +10,-10%	9	7.5	5.0	A3B	B3B	N3A
DEHR33D561K□□□	2000	560 +10,-10%	9	7.5	5.0	A3B	B3B	N3A
DEHR33D681K□□□	2000	680 +10,-10%	10	7.5	5.0	A3B	B3B	N3A
DEHR33D821K□□□	2000	820 +10,-10%	11	7.5	5.0	A3B	B3B	N3A
DEHR33D102K□□□	2000	1000 +10,-10%	12	7.5	5.0	A3B	B3B	N3A
DEHR33D122K□□□	2000	1200 +10,-10%	12	7.5	5.0	A3B	B3B	N3A
DEHR33D152K□□□	2000	1500 +10,-10%	12	7.5	5.0	A3B	B3B	N3A
DEHR33D182K□□□	2000	1800 +10,-10%	14	7.5	5.0	A3B	B3B	N7A

Continued on the following page. ↗

↳ Continued from the preceding page.

Part Number	DC Rated Voltage (Vdc)	Capacitance (pF)	Body Dia. D (mm)	Lead Spacing F (mm)	Body Thickness T (mm)	Lead Package Long Bulk	Lead Package Short Bulk	Lead Package Taping
DEHR33D222K□□□	2000	2200 +10,-10%	15	7.5	5.0	A3B	B3B	N7A
DEHR33D272K□□□	2000	2700 +10,-10%	17	7.5	5.0	A3B	B3B	N7A
DEHR33D332K□□□	2000	3300 +10,-10%	19	10.0	5.0	A4B	B4B	-
DEHR33D392K□□□	2000	3900 +10,-10%	20	10.0	5.0	A4B	B4B	-
DEHR33D472K□□□	2000	4700 +10,-10%	21	10.0	5.0	A4B	B4B	-
DEHR33F151K□□□	3150	150 +10,-10%	7	7.5	6.0	C3B	D3B	P3A
DEHR33F181K□□□	3150	180 +10,-10%	7	7.5	6.0	C3B	D3B	P3A
DEHR33F221K□□□	3150	220 +10,-10%	7	7.5	6.0	C3B	D3B	P3A
DEHR33F271K□□□	3150	270 +10,-10%	7	7.5	6.0	C3B	D3B	P3A
DEHR33F331K□□□	3150	330 +10,-10%	8	7.5	6.0	A3B	B3B	N3A
DEHR33F391K□□□	3150	390 +10,-10%	9	7.5	6.0	A3B	B3B	N3A
DEHR33F471K□□□	3150	470 +10,-10%	10	7.5	6.0	A3B	B3B	N3A
DEHR33F561K□□□	3150	560 +10,-10%	10	7.5	6.0	A3B	B3B	N3A
DEHR33F681K□□□	3150	680 +10,-10%	11	7.5	6.0	A3B	B3B	N3A
DEHR33F821K□□□	3150	820 +10,-10%	12	7.5	6.0	A3B	B3B	N3A
DEHR33F102K□□□	3150	1000 +10,-10%	13	7.5	6.0	A3B	B3B	N3A
DEHR33F122K□□□	3150	1200 +10,-10%	14	7.5	6.0	A3B	B3B	N7A
DEHR33F152K□□□	3150	1500 +10,-10%	15	7.5	6.0	A3B	B3B	N7A
DEHR33F182K□□□	3150	1800 +10,-10%	16	7.5	6.0	A3B	B3B	N7A
DEHR33F222K□□□	3150	2200 +10,-10%	17	7.5	6.0	A3B	B3B	N7A
DEHR33F272K□□□	3150	2700 +10,-10%	19	10.0	6.0	A4B	B4B	-

Three blank columns are filled with the lead and packaging codes. Please refer to the 3 columns on the right for the appropriate code.

2

Specifications and Test Methods

No.	Item	Specifications	Testing Method											
1	Operating Temperature Range	-25 to +125°C												
2	Appearance and Dimensions	No marked defect on appearance form and dimensions are within specified range.	The capacitor should be visually inspected for evidence of defect. Dimensions should be measured with slide calipers.											
3	Marking	To be easily legible.	The capacitor should be visually inspected.											
4	Dielectric Strength	Between Lead Wires	No failure. The capacitor should not be damaged when DC voltage of 200% of the rated voltage (DC1 to 3.15kV) or DC voltage of 250% of the rated voltage (DC250V, DC500V) is applied between the lead wires for 1 to 5 sec. (Charge/Discharge current \leq 50mA.)											
		Body Insulation	No failure. The capacitor is placed in the container with metal balls of diameter 1mm so that each lead wire, shortcircuited, is kept about 2mm off the metal balls as shown in the figure at right, and AC1250V (r.m.s.) <50/60Hz> is applied for 1 to 5 sec. between capacitor lead wires and metal balls. (Charge/Discharge current \leq 50mA.)											
5	Insulation Resistance (I.R.)	Between Lead Wires Char. R[DC1 to 3.15kV], Char. C : 10000M Ω min. Char. R[DC250V] : 1000M Ω min.	The insulation resistance should be measured with DC500 \pm 50V (Char. R[DC 250V]: DC100 \pm 15V) within 60 \pm 5 sec. of charging.											
6	Capacitance	Within specified tolerance.	The capacitance should be measured at 20°C with 1 \pm 0.2kHz and AC5V(r.m.s.) max.											
7	Dissipation Factor (D.F.)	Char. R[DC250V] : 0.4% max. Char. R[DC1 to 3.15kV] : 0.2% max. Char. C : 0.3% max.	The dissipation factor should be measured at 20°C with 1 \pm 0.2kHz and AC5V(r.m.s.) max.											
8	Temperature Characteristics	<table border="1"> <thead> <tr> <th rowspan="2">T. C.</th> <th colspan="2">Temp. char.</th> </tr> <tr> <th>-25 to +85°C</th> <th>+85 to +125°C</th> </tr> </thead> <tbody> <tr> <td>R</td> <td>Within \pm15%</td> <td rowspan="2">Within +15/-30%</td> </tr> <tr> <td>C</td> <td>Within \pm20%</td> </tr> </tbody> </table>	T. C.	Temp. char.		-25 to +85°C	+85 to +125°C	R	Within \pm 15%	Within +15/-30%	C	Within \pm 20%	The capacitance measurement should be made at each step specified in Table.	
		T. C.		Temp. char.										
-25 to +85°C	+85 to +125°C													
R	Within \pm 15%	Within +15/-30%												
C	Within \pm 20%													
Pre-treatment : Capacitor should be stored at 125 \pm 3°C for 1 hr., then placed at *room condition for 24 \pm 2 hrs. before measurements. <table border="1"> <thead> <tr> <th>Step</th> <th>1</th> <th>2</th> <th>3</th> <th>4</th> <th>5</th> </tr> </thead> <tbody> <tr> <td>Temp.(°C)</td> <td>20\pm2</td> <td>-25\pm3</td> <td>20\pm2</td> <td>125\pm2</td> <td>20\pm2</td> </tr> </tbody> </table>			Step	1	2	3	4	5	Temp.(°C)	20 \pm 2	-25 \pm 3	20 \pm 2	125 \pm 2	20 \pm 2
Step	1	2	3	4	5									
Temp.(°C)	20 \pm 2	-25 \pm 3	20 \pm 2	125 \pm 2	20 \pm 2									
9	Strength of Lead	Pull	As shown in the figure at right, fix the body of the capacitor and apply a tensile weight gradually to each lead wire in the radial direction of the capacitor up to 10N (5N for lead diameter 0.5mm), and keep it for 10 \pm 1 sec.											
		Bending	Each lead wire should be subjected to 5N (2.5N for lead diameter 0.5mm) of weight and bent 90° at the point of egress, in one direction, then returned to its original position and bent 90° in the opposite direction at the rate of one bend in 2 to 3 sec.											
10	Vibration Resistance	Appearance	No marked defect.											
		Capacitance	Within specified tolerance.											
		D.F.	Char. R[DC250V] : 0.4% max. Char. R[DC1 to 3.15kV] : 0.2% max. Char. C : 0.3% max.											
11	Solderability of Leads	Lead wire should be soldered with uniform coating on the axial direction over 3/4 of the circumferential direction.	The lead wire of a capacitor should be dipped into a ethanol solution of 25wt% rosin and then into molten solder of 235 \pm 5°C for 2 \pm 0.5 sec. In both cases the depth of dipping is up to about 1.5 to 2mm from the root of lead wires.											
12	Soldering Effect	Appearance	No marked defect.											
		Capacitance Change	Within \pm 10%											
		Dielectric Strength (Between Lead Wires)	Per item 4.											

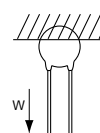
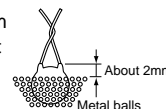

* "room condition" Temperature: 15 to 35°C, Relative humidity: 45 to 75%, Atmospheric pressure: 86 to 106kPa

Specifications and Test Methods

Continued from the preceding page.

No.	Item	Specifications	Testing Method															
13	Temperature Cycle	Appearance	The capacitor should be subjected to 5 temperature cycles. <Temperature cycle> <table border="1" style="margin: 10px auto;"> <thead> <tr> <th>Step</th> <th>Temperature(°C)</th> <th>Time(min)</th> </tr> </thead> <tbody> <tr> <td>1</td> <td>-25±3</td> <td>30</td> </tr> <tr> <td>2</td> <td>Room Temp.</td> <td>3</td> </tr> <tr> <td>3</td> <td>125±3</td> <td>30</td> </tr> <tr> <td>4</td> <td>Room Temp.</td> <td>3</td> </tr> </tbody> </table> Cycle time : 5 cycle Pre-treatment : Capacitor should be stored at 125±3°C for 1 hr., then placed at *1room condition for 24±2 hrs. before initial measurements. Post-treatment : Capacitor should be stored for 24±2 hrs. at *1room condition. Measurement order : I.R. · Dielectric strength -> Pre-treatment -> Capacitance · D.F. -> Temperature cycle test -> Post-treatment -> Capacitance · D.F. · I.R. · Dielectric strength (Char. R[DC250V])	Step	Temperature(°C)	Time(min)	1	-25±3	30	2	Room Temp.	3	3	125±3	30	4	Room Temp.	3
		Step		Temperature(°C)	Time(min)													
		1		-25±3	30													
		2		Room Temp.	3													
3	125±3	30																
4	Room Temp.	3																
Capacitance Change	Within ±10%																	
D.F.	0.4% max.																	
I.R.	1000MΩ min.																	
14	Humidity (Under Steady State)	Appearance	Set the capacitor for 500 +24/-0 hrs. at 40±2°C in 90 to 95% relative humidity. Pre-treatment : Capacitor should be stored at 125±3°C for 1 hr., then placed at *1room condition for 24±2 hrs. before initial measurements. Post-treatment : Capacitor should be stored for 1 to 2 hrs. at *1room condition. Measurement order : I.R. -> Pre-treatment -> Capacitance · D.F. -> Humidity test -> Post-treatment -> Capacitance · D.F. · I.R. (Char. R[DC250V])															
		Capacitance Change		Within ±10%														
		D.F.		0.4% max.														
		I.R.		1000MΩ min.														
15	Humidity Loading	Appearance	Apply the rated voltage for 500 +24/-0 hrs. at 40±2°C in 90 to 95% relative humidity. (Charge/Discharge current≤50mA.) Pre-treatment : Capacitor should be stored at 125±3°C for 1 hr., then placed at *1room condition for 24±2 hrs. before initial measurements. Post-treatment : Capacitor should be stored for 1 to 2 hrs. at *1room condition. (Char. R[DC1 to 3.15kV], Char. C) Post-treatment : Capacitor should be stored at 125±3°C for 1 hr., then placed at *1room condition for 24±2 hrs. (Char. R[DC250V]) Measurement order : I.R. -> Pre-treatment -> Capacitance · D.F. -> Humidity loading test -> *2 I.R. -> Post-treatment -> Capacitance · D.F. (Char. R[DC250V])															
		Capacitance Change		Within ±10%														
		D.F.		0.6% max.														
		I.R.		1000MΩ min.														
16	Life	Appearance	Apply a DC voltage of 200% of the rated voltage (DC250V, DC500V) or DC voltage of 150% of the rated voltage (DC1 to 3.15kV) for 1000 +48/-0 hrs. at 125±2°C with a relative humidity of 50% max. (Charge/Discharge current≤50mA.) Pre-treatment : Capacitor should be stored at 125±3°C for 1 hr., then placed at *1room condition for 24±2 hrs. before initial measurements. Post-treatment : Capacitor should be stored at 125±3°C for 1 hr., then placed at *1room condition for 24±2 hrs. Measurement order : I.R. -> Pre-treatment -> Capacitance · D.F. -> Life test -> *3I.R. -> Post-treatment -> Capacitance · D.F. (Char. R[DC250V])															
		Capacitance Change		Within ±10%														
		D.F.		0.4% max.														
		I.R.		Char. R[DC1 to 3.15kV], Char. C : 2000MΩ min. Char. R[DC250V] : 1000MΩ min.														

*1 "room condition" Temperature: 15 to 35°C, Relative humidity: 45 to 75%, Atmospheric pressure: 86 to 106kPa

*2 The measurement of I.R. will be held in 1 to 2 hrs. after Humidity loading test.

*3 The measurement of I.R. will be held in 12 to 24 hrs. after Life test.

High Voltage Ceramic Capacitors (DC250V-6.3kV)



DEA Series (125 deg. C Guaranteed/Class 1/DC1k-3.15kV)

■ Features

1. Temperature compensating type ceramics realize low heat dissipation than DEH/DES series.
2. Operating temperature range is guaranteed up to 125 degree C.
3. Coated with flame-retardant epoxy resin (equivalent to UL94V-0 standards).
4. We eliminated lead (Pb) from plating lead wires.
5. Taping available for automatic insertion.

■ Applications

- Ideal for use as the ballast in backlighting inverters for liquid crystal display.
- Ideal for use on high frequency pulse circuits such as a horizontal resonance circuit for CTV and snubber circuits for switching power supplies.

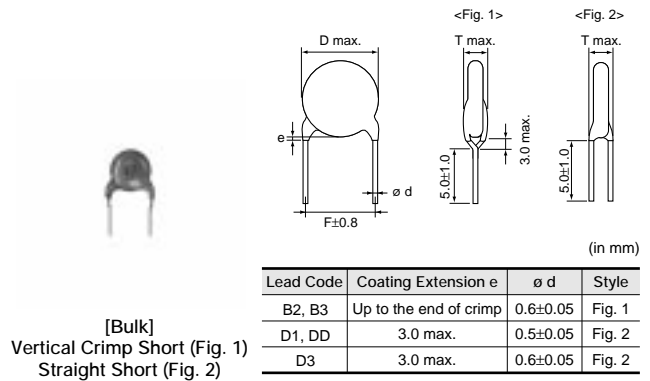
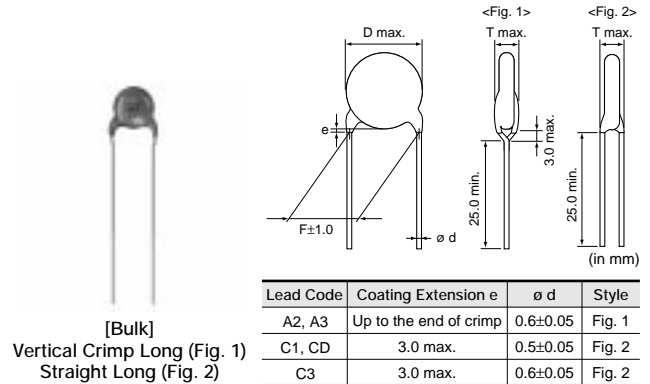

■ Marking

Temp. Char.	SL
Nominal body diameter	
ø4.5-5mm	68 1KV
ø6mm	39 3KV 66
ø7-9mm	181J 2KV 66
ø10-16mm	391J 3KV M 66
Nominal Capacitance	Under 100pF : Actual value, 100pF and over : Marked with 3 figures
Capacitance Tolerance	Marked with code (omitted for nominal body diameter ø6mm and under)
Rated Voltage	Marked with code (In case of DC3.15kV, marked with 3KV)
Manufacturer's Identification	Marked with M (omitted for nominal body diameter ø9mm and under)
Manufactured Date Code	Abbreviation (omitted for nominal body diameter ø5mm and under)

SL Characteristics

Part Number	DC Rated Voltage (Vdc)	Capacitance (pF)	Body Dia. D (mm)	Lead Spacing F (mm)	Body Thickness T (mm)	Lead Package Long Bulk	Lead Package Short Bulk	Lead Package Taping
DEA1X3A100J□□□	1000	10 +5,-5%	4.5	5.0	4.0	C1B	D1B	P2A
DEA1X3A120J□□□	1000	12 +5,-5%	4.5	5.0	4.0	C1B	D1B	P2A
DEA1X3A150J□□□	1000	15 +5,-5%	4.5	5.0	4.0	C1B	D1B	P2A
DEA1X3A180J□□□	1000	18 +5,-5%	4.5	5.0	4.0	C1B	D1B	P2A
DEA1X3A220J□□□	1000	22 +5,-5%	4.5	5.0	4.0	C1B	D1B	P2A
DEA1X3A270J□□□	1000	27 +5,-5%	4.5	5.0	4.0	C1B	D1B	P2A
DEA1X3A330J□□□	1000	33 +5,-5%	4.5	5.0	4.0	C1B	D1B	P2A
DEA1X3A390J□□□	1000	39 +5,-5%	4.5	5.0	4.0	C1B	D1B	P2A
DEA1X3A470J□□□	1000	47 +5,-5%	4.5	5.0	4.0	C1B	D1B	P2A
DEA1X3A560J□□□	1000	56 +5,-5%	5	5.0	4.0	C1B	D1B	P2A
DEA1X3A680J□□□	1000	68 +5,-5%	5	5.0	4.0	C1B	D1B	P2A
DEA1X3A820J□□□	1000	82 +5,-5%	6	5.0	4.0	A2B	B2B	N2A
DEA1X3A101J□□□	1000	100 +5,-5%	6	5.0	4.0	A2B	B2B	N2A
DEA1X3A121J□□□	1000	120 +5,-5%	6	5.0	4.0	A2B	B2B	N2A
DEA1X3A151J□□□	1000	150 +5,-5%	7	5.0	4.0	A2B	B2B	N2A
DEA1X3A181J□□□	1000	180 +5,-5%	7	5.0	4.0	A2B	B2B	N2A
DEA1X3A221J□□□	1000	220 +5,-5%	8	5.0	4.0	A2B	B2B	N2A
DEA1X3A271J□□□	1000	270 +5,-5%	9	5.0	4.0	A2B	B2B	N2A
DEA1X3A331J□□□	1000	330 +5,-5%	10	5.0	4.0	A2B	B2B	N2A
DEA1X3A391J□□□	1000	390 +5,-5%	10	5.0	4.0	A2B	B2B	N2A
DEA1X3A471J□□□	1000	470 +5,-5%	11	5.0	4.0	A2B	B2B	N2A
DEA1X3A561J□□□	1000	560 +5,-5%	12	7.5	4.0	A3B	B3B	N3A
DEA1X3D100J□□□	2000	10 +5,-5%	4.5	5.0	5.0	C1B	D1B	P2A
DEA1X3D120J□□□	2000	12 +5,-5%	4.5	5.0	5.0	C1B	D1B	P2A
DEA1X3D150J□□□	2000	15 +5,-5%	4.5	5.0	5.0	C1B	D1B	P2A
DEA1X3D180J□□□	2000	18 +5,-5%	4.5	5.0	5.0	C1B	D1B	P2A
DEA1X3D220J□□□	2000	22 +5,-5%	4.5	5.0	5.0	C1B	D1B	P2A
DEA1X3D270J□□□	2000	27 +5,-5%	4.5	5.0	5.0	C1B	D1B	P2A
DEA1X3D330J□□□	2000	33 +5,-5%	4.5	5.0	5.0	C1B	D1B	P2A
DEA1X3D390J□□□	2000	39 +5,-5%	5	5.0	5.0	C1B	D1B	P2A
DEA1X3D470J□□□	2000	47 +5,-5%	6	5.0	5.0	A2B	B2B	N2A
DEA1X3D560J□□□	2000	56 +5,-5%	6	5.0	5.0	A2B	B2B	N2A
DEA1X3D680J□□□	2000	68 +5,-5%	6	5.0	5.0	A2B	B2B	N2A
DEA1X3D820J□□□	2000	82 +5,-5%	7	5.0	5.0	A2B	B2B	N2A
DEA1X3D101J□□□	2000	100 +5,-5%	7	5.0	5.0	A2B	B2B	N2A
DEA1X3D121J□□□	2000	120 +5,-5%	8	5.0	5.0	A2B	B2B	N2A
DEA1X3D151J□□□	2000	150 +5,-5%	8	5.0	5.0	A2B	B2B	N2A
DEA1X3D181J□□□	2000	180 +5,-5%	9	5.0	5.0	A2B	B2B	N2A
DEA1X3D221J□□□	2000	220 +5,-5%	10	5.0	5.0	A2B	B2B	N2A
DEA1X3D271J□□□	2000	270 +5,-5%	11	5.0	5.0	A2B	B2B	N2A
DEA1X3D331J□□□	2000	330 +5,-5%	12	7.5	5.0	A3B	B3B	N3A
DEA1X3D391J□□□	2000	390 +5,-5%	13	7.5	5.0	A3B	B3B	N3A
DEA1X3D471J□□□	2000	470 +5,-5%	14	7.5	5.0	A3B	B3B	N7A
DEA1X3D561J□□□	2000	560 +5,-5%	15	7.5	5.0	A3B	B3B	N7A
DEA1X3F100J□□□	3150	10 +5,-5%	5	7.5	6.0	CDB	DDB	P3A
DEA1X3F120J□□□	3150	12 +5,-5%	5	7.5	6.0	CDB	DDB	P3A
DEA1X3F150J□□□	3150	15 +5,-5%	5	7.5	6.0	CDB	DDB	P3A
DEA1X3F180J□□□	3150	18 +5,-5%	5	7.5	6.0	CDB	DDB	P3A
DEA1X3F220J□□□	3150	22 +5,-5%	5	7.5	6.0	CDB	DDB	P3A
DEA1X3F270J□□□	3150	27 +5,-5%	6	7.5	6.0	C3B	D3B	P3A
DEA1X3F330J□□□	3150	33 +5,-5%	6	7.5	6.0	C3B	D3B	P3A
DEA1X3F390J□□□	3150	39 +5,-5%	6	7.5	6.0	C3B	D3B	P3A
DEA1X3F470J□□□	3150	47 +5,-5%	7	7.5	6.0	C3B	D3B	P3A
DEA1X3F560J□□□	3150	56 +5,-5%	7	7.5	6.0	C3B	D3B	P3A

Continued on the following page. 

↳ Continued from the preceding page.

Part Number	DC Rated Voltage (Vdc)	Capacitance (pF)	Body Dia. D (mm)	Lead Spacing F (mm)	Body Thickness T (mm)	Lead Package Long Bulk	Lead Package Short Bulk	Lead Package Taping
DEA1X3F680J□□□	3150	68 +5,-5%	8	7.5	6.0	A3B	B3B	N3A
DEA1X3F820J□□□	3150	82 +5,-5%	8	7.5	6.0	A3B	B3B	N3A
DEA1X3F101J□□□	3150	100 +5,-5%	9	7.5	6.0	A3B	B3B	N3A
DEA1X3F121J□□□	3150	120 +5,-5%	10	7.5	6.0	A3B	B3B	N3A
DEA1X3F151J□□□	3150	150 +5,-5%	11	7.5	6.0	A3B	B3B	N3A
DEA1X3F181J□□□	3150	180 +5,-5%	11	7.5	6.0	A3B	B3B	N3A
DEA1X3F221J□□□	3150	220 +5,-5%	12	7.5	6.0	A3B	B3B	N3A
DEA1X3F271J□□□	3150	270 +5,-5%	14	7.5	6.0	A3B	B3B	N7A
DEA1X3F331J□□□	3150	330 +5,-5%	15	7.5	6.0	A3B	B3B	N7A
DEA1X3F391J□□□	3150	390 +5,-5%	16	7.5	6.0	A3B	B3B	N7A

Three blank columns are filled with the lead and packaging codes. Please refer to the 3 columns on the right for the appropriate code.

Specifications and Test Methods

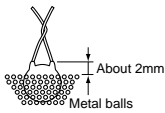
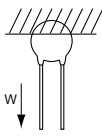
No.	Item	Specifications	Testing Method									
1	Operating Temperature Range	-25 to +125°C										
2	Appearance and Dimensions	No marked defect on appearance form and dimensions are within specified range.	The capacitor should be visually inspected for evidence of defect. Dimensions should be measured with slide calipers.									
3	Marking	To be easily legible.	The capacitor should be visually inspected.									
4	Dielectric Strength	Between Lead Wires No failure.	The capacitor should not be damaged when DC voltage of 200% of the rated voltage is applied between the lead wires for 1 to 5 sec. (Charge/Discharge current ≤ 50mA.)									
		Body Insulation No failure.	The capacitor is placed in the container with metal balls of diameter 1mm so that each lead wire, shortcircuited, is kept about 2mm off the metal balls as shown in the figure at right, and AC1250V (r.m.s.) <50/60Hz> is applied for 1 to 5 sec. between capacitor lead wires and metal balls. (Charge/Discharge current ≤ 50mA.) 									
5	Insulation Resistance (I.R.)	Between Lead Wires 10000MΩ min.	The insulation resistance should be measured with DC500±50V within 60±5 sec. of charging.									
6	Capacitance	Within specified tolerance.	The capacitance should be measured at 20°C with 1±0.2MHz and AC5V(r.m.s.) max.									
7	Q	400+20C* ² min. (30pF under) 1000 min. (30pF min.)	The dissipation factor should be measured at 20°C with 1±0.2MHz and AC5V(r.m.s.) max.									
8	Temperature Characteristics	+350 to -1000ppm/°C (Temp. range: +20 to +85°C)	The capacitance measurement should be made at each step specified in Table.									
		<table border="1" style="margin-left: auto; margin-right: auto;"> <thead> <tr> <th>Step</th> <th>1</th> <th>2</th> <th>3</th> <th>4</th> <th>5</th> </tr> </thead> <tbody> <tr> <td>Temp.(°C)</td> <td>20±2</td> <td>-25±3</td> <td>20±2</td> <td>85±2</td> <td>20±2</td> </tr> </tbody> </table>		Step	1	2	3	4	5	Temp.(°C)	20±2	-25±3
Step	1	2	3	4	5							
Temp.(°C)	20±2	-25±3	20±2	85±2	20±2							
9	Strength of Lead	Pull Lead wire should not be cut off. Capacitor should not be broken.	As shown in the figure at right, fix the body of the capacitor and apply a tensile weight gradually to each lead wire in the radial direction of the capacitor up to 10N (5N for lead diameter 0.5mm), and keep it for 10±1 sec. 									
		Bending Each lead wire should be subjected to 5N (2.5N for lead diameter 0.5mm) of weight and bent 90° at the point of egress, in one direction, then returned to its original position and bent 90° in the opposite direction at the rate of one bend in 2 to 3 sec.										
10	Vibration Resistance	Appearance No marked defect.	The capacitor should be firmly soldered to the supporting lead wire and vibrated at a frequency range of 10 to 55Hz, 1.5mm in total amplitude, with about a 1 minute rate of vibration change from 10Hz to 55Hz and back to 10Hz. Apply for a total of 6 hrs., 2 hrs. each in 3 mutually perpendicular directions.									
		Capacitance Within specified tolerance.										
		Q 400+20C* ² min. (30pF under) 1000 min. (30pF min.)										
11	Solderability of Leads	Lead wire should be soldered with uniform coating on the axial direction over 3/4 of the circumferential direction.	The lead wire of a capacitor should be dipped into a ethanol solution of 25wt% rosin and then into molten solder of 235±5°C for 2±0.5 sec. In both cases the depth of dipping is up to about 1.5 to 2mm from the root of lead wires.									
12	Soldering Effect	Appearance No marked defect.	The lead wire should be immersed into the melted solder of 350±10°C (Body of ø5mm and under: 270±5°C) up to about 1.5 to 2mm from the main body for 3.5±0.5 sec. (Body of ø5mm and under: 5±0.5 sec.) Post-treatment : Capacitor should be stored for 1 to 2 hrs. at *1 room condition.									
		Capacitance Change Within ±2.5%										
		Dielectric Strength (Between Lead Wires) Per item 4.										

*1 "room condition" Temperature: 15 to 35°C, Relative humidity: 45 to 75%, Atmospheric pressure: 86 to 106kPa

*2 "C" expresses nominal capacitance value (pF)

Continued on the following page. 

Specifications and Test Methods

Continued from the preceding page.

No.	Item	Specifications	Testing Method															
13	Temperature Cycle	Appearance	No marked defect.															
		Capacitance Change	Within ±5%															
		Q	275+5/2C* ² min. (30pF under) 350 min. (30pF min.)															
		I.R.	1000MΩ min.															
		Dielectric Strength (Between Lead Wires)	Per item 4.															
			The capacitor should be subjected to 5 temperature cycles. <Temperature cycle> <table border="1" style="margin-left: auto; margin-right: auto;"> <thead> <tr> <th>Step</th> <th>Temperature(°C)</th> <th>Time(min)</th> </tr> </thead> <tbody> <tr> <td>1</td> <td>-25±3</td> <td>30</td> </tr> <tr> <td>2</td> <td>Room Temp.</td> <td>3</td> </tr> <tr> <td>3</td> <td>125±3</td> <td>30</td> </tr> <tr> <td>4</td> <td>Room Temp.</td> <td>3</td> </tr> </tbody> </table> Cycle time : 5 cycle Post-treatment : Capacitor should be stored for 1 to 2 hrs. at *1room condition.	Step	Temperature(°C)	Time(min)	1	-25±3	30	2	Room Temp.	3	3	125±3	30	4	Room Temp.	3
Step	Temperature(°C)	Time(min)																
1	-25±3	30																
2	Room Temp.	3																
3	125±3	30																
4	Room Temp.	3																
14	Humidity (Under Steady State)	Appearance	No marked defect.															
		Capacitance Change	Within ±5%															
		Q	275+5/2C* ² min. (30pF under) 350 min. (30pF min.)															
		I.R.	1000MΩ min.															
			Set the capacitor for 500 +24/-0 hrs. at 40±2°C in 90 to 95% relative humidity. Post-treatment : Capacitor should be stored for 1 to 2 hrs. at *1room condition.															
15	Humidity Loading	Appearance	No marked defect.															
		Capacitance Change	Within ±5%															
		Q	275+5/2C* ² min. (30pF under) 350 min. (30pF min.)															
		I.R.	1000MΩ min.															
			Apply the rated voltage for 500 +24/-0 hrs. at 40±2°C in 90 to 95% relative humidity. (Charge/Discharge current≤50mA.) Post-treatment : Capacitor should be stored for 1 to 2 hrs. at *1room condition.															
16	Life	Appearance	No marked defect.															
		Capacitance Change	Within ±3%															
		Q	275+5/2C* ² min. (30pF under) 350 min. (30pF min.)															
		I.R.	2000MΩ min.															
			Apply a DC voltage of 150% of the rated voltage for 1000 +48/-0 hrs. at 125±2°C with a relative humidity of 50% max. (Charge/Discharge current≤50mA.) Post-treatment : Capacitor should be stored for 1 to 2 hrs. at *1room condition.															

*1 "room condition" Temperature: 15 to 35°C, Relative humidity: 45 to 75%, Atmospheric pressure: 86 to 106kPa

*2 "C" expresses nominal capacitance value (pF)

High Voltage Ceramic Capacitors (DC250V-6.3kV)



DEB Series (Class 2/DC1k-3.15kV)

■ Features

1. Small size and high capacitance
2. Coated with flame-retardant epoxy resin (equivalent to UL94V-0 standards).
3. We eliminated lead (Pb) from plating lead wires.
4. Taping available for automatic insertion.

■ Applications

Ideal for use on decoupling circuits for power supplies.

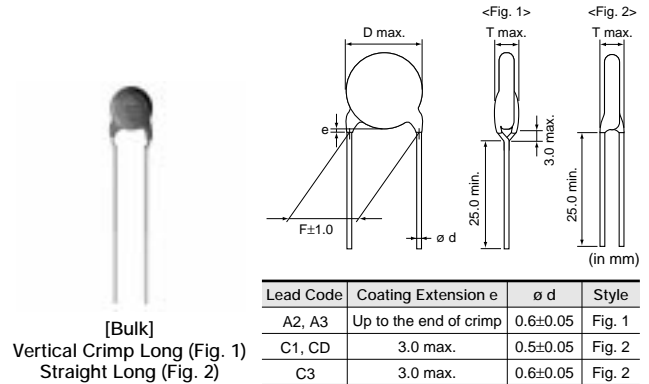

[Bulk]
Vertical Crimp Long (Fig. 1)
Straight Long (Fig. 2)

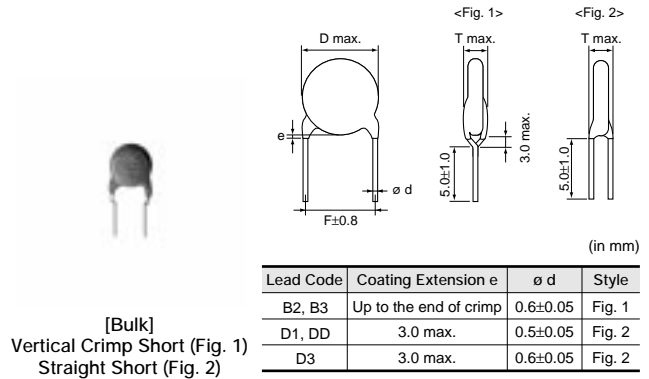

[Bulk]
Vertical Crimp Short (Fig. 1)
Straight Short (Fig. 2)

■ Marking

Nominal body diameter	Temp. Char.	B	E	F
	ø4.5-5mm		221 3KV	102 1KV
ø6mm		331 3KV 66	102 2KV 66	222 1KV 66
ø7-9mm		102K 3KV 66	102Z 3KV 66	472Z 2KV 66
ø10-16mm		B 332K 3KV M 66	E 472Z 3KV M 66	103Z 2KV M 66
Temperature Characteristics	Marked with code for char. B and E (omitted for nominal body diameter ø9mm and under)			
Nominal Capacitance	Marked with 3 figures			
Capacitance Tolerance	Marked with code (omitted for nominal body diameter ø6mm and under)			
Rated Voltage	Marked with code (In case of DC3.15kV, marked with 3KV)			
Manufacturer's Identification	Marked with M (omitted for nominal body diameter ø9mm and under)			
Manufactured Date Code	Abbreviation (omitted for nominal body diameter ø5mm and under)			

B Characteristics

Part Number	DC Rated Voltage (Vdc)	Capacitance (pF)	Body Dia. D (mm)	Lead Spacing F (mm)	Body Thickness T (mm)	Lead Package Long Bulk	Lead Package Short Bulk	Lead Package Taping
DEBB33A101K□□□	1000	100 +10,-10%	4.5	5.0	4.0	C1B	D1B	P2A
DEBB33A151K□□□	1000	150 +10,-10%	4.5	5.0	4.0	C1B	D1B	P2A
DEBB33A221K□□□	1000	220 +10,-10%	4.5	5.0	4.0	C1B	D1B	P2A
DEBB33A331K□□□	1000	330 +10,-10%	4.5	5.0	4.0	C1B	D1B	P2A
DEBB33A471K□□□	1000	470 +10,-10%	5	5.0	4.0	C1B	D1B	P2A
DEBB33A681K□□□	1000	680 +10,-10%	6	5.0	4.0	A2B	B2B	N2A
DEBB33A102K□□□	1000	1000 +10,-10%	6	5.0	4.0	A2B	B2B	N2A
DEBB33A152K□□□	1000	1500 +10,-10%	8	5.0	4.0	A2B	B2B	N2A
DEBB33A222K□□□	1000	2200 +10,-10%	9	5.0	4.0	A2B	B2B	N2A
DEBB33A332K□□□	1000	3300 +10,-10%	10	5.0	4.0	A2B	B2B	N2A
DEBB33A472K□□□	1000	4700 +10,-10%	12	7.5	4.0	A3B	B3B	N3A
DEBB33A682K□□□	1000	6800 +10,-10%	15	7.5	4.0	A3B	B3B	N7A
DEBB33D101K□□□	2000	100 +10,-10%	4.5	5.0	5.0	C1B	D1B	P2A
DEBB33D151K□□□	2000	150 +10,-10%	4.5	5.0	5.0	C1B	D1B	P2A
DEBB33D221K□□□	2000	220 +10,-10%	4.5	5.0	5.0	C1B	D1B	P2A
DEBB33D331K□□□	2000	330 +10,-10%	5	5.0	5.0	C1B	D1B	P2A
DEBB33D471K□□□	2000	470 +10,-10%	6	5.0	5.0	A2B	B2B	N2A
DEBB33D681K□□□	2000	680 +10,-10%	7	5.0	5.0	A2B	B2B	N2A
DEBB33D102K□□□	2000	1000 +10,-10%	8	5.0	5.0	A2B	B2B	N2A
DEBB33D152K□□□	2000	1500 +10,-10%	9	5.0	5.0	A2B	B2B	N2A
DEBB33D222K□□□	2000	2200 +10,-10%	10	5.0	5.0	A2B	B2B	N2A
DEBB33D332K□□□	2000	3300 +10,-10%	12	7.5	5.0	A3B	B3B	N3A
DEBB33D472K□□□	2000	4700 +10,-10%	15	7.5	5.0	A3B	B3B	N7A
DEBB33F101K□□□	3150	100 +10,-10%	5	7.5	6.0	CDB	DDB	P3A
DEBB33F151K□□□	3150	150 +10,-10%	5	7.5	6.0	CDB	DDB	P3A
DEBB33F221K□□□	3150	220 +10,-10%	5	7.5	6.0	CDB	DDB	P3A
DEBB33F331K□□□	3150	330 +10,-10%	6	7.5	6.0	C3B	D3B	P3A
DEBB33F471K□□□	3150	470 +10,-10%	7	7.5	6.0	C3B	D3B	P3A
DEBB33F681K□□□	3150	680 +10,-10%	8	7.5	6.0	A3B	B3B	N3A
DEBB33F102K□□□	3150	1000 +10,-10%	9	7.5	6.0	A3B	B3B	N3A
DEBB33F152K□□□	3150	1500 +10,-10%	11	7.5	6.0	A3B	B3B	N3A
DEBB33F222K□□□	3150	2200 +10,-10%	13	7.5	6.0	A3B	B3B	N3A
DEBB33F332K□□□	3150	3300 +10,-10%	15	7.5	6.0	A3B	B3B	N7A

Three blank columns are filled with the lead and packaging codes. Please refer to the 3 columns on the right for the appropriate code.

E Characteristics

Part Number	DC Rated Voltage (Vdc)	Capacitance (pF)	Body Dia. D (mm)	Lead Spacing F (mm)	Body Thickness T (mm)	Lead Package Long Bulk	Lead Package Short Bulk	Lead Package Taping
DEBE33A102Z□□□	1000	1000 +80,-20%	5	5.0	4.0	C1B	D1B	P2A
DEBE33A222Z□□□	1000	2200 +80,-20%	7	5.0	4.0	A2B	B2B	N2A
DEBE33A472Z□□□	1000	4700 +80,-20%	9	5.0	4.0	A2B	B2B	N2A
DEBE33A103Z□□□	1000	10000 +80,-20%	13	7.5	4.0	A3B	B3B	N3A
DEBE33D102Z□□□	2000	1000 +80,-20%	6	5.0	5.0	A2B	B2B	N2A
DEBE33D222Z□□□	2000	2200 +80,-20%	8	5.0	5.0	A2B	B2B	N2A
DEBE33D472Z□□□	2000	4700 +80,-20%	11	5.0	5.0	A2B	B2B	N2A
DEBE33D103Z□□□	2000	10000 +80,-20%	16	7.5	5.0	A3B	B3B	N7A
DEBE33F102Z□□□	3150	1000 +80,-20%	7	7.5	6.0	C3B	D3B	P3A
DEBE33F222Z□□□	3150	2200 +80,-20%	10	7.5	6.0	A3B	B3B	N3A
DEBE33F472Z□□□	3150	4700 +80,-20%	13	7.5	6.0	A3B	B3B	N3A

Three blank columns are filled with the lead and packaging codes. Please refer to the 3 columns on the right for the appropriate code.

F Characteristics

Part Number	DC Rated Voltage (Vdc)	Capacitance (pF)	Body Dia. D (mm)	Lead Spacing F (mm)	Body Thickness T (mm)	Lead Package Long Bulk	Lead Package Short Bulk	Lead Package Taping
DEBF33A222Z□□□	1000	2200 +80,-20%	6	5.0	4.0	A2B	B2B	N2A
DEBF33A472Z□□□	1000	4700 +80,-20%	7	5.0	4.0	A2B	B2B	N2A
DEBF33A103Z□□□	1000	10000 +80,-20%	10	5.0	4.0	A2B	B2B	N2A
DEBF33D102Z□□□	2000	1000 +80,-20%	5	5.0	5.0	C1B	D1B	P2A
DEBF33D222Z□□□	2000	2200 +80,-20%	7	5.0	5.0	A2B	B2B	N2A
DEBF33D472Z□□□	2000	4700 +80,-20%	9	5.0	5.0	A2B	B2B	N2A
DEBF33D103Z□□□	2000	10000 +80,-20%	12	7.5	5.0	A3B	B3B	N3A

Three blank columns are filled with the lead and packaging codes. Please refer to the 3 columns on the right for the appropriate code.

Specifications and Test Methods

No.	Item	Specifications	Testing Method												
1	Operating Temperature Range	-25 to +85°C													
2	Appearance and Dimensions	No marked defect on appearance form and dimensions are within specified range.	The capacitor should be visually inspected for evidence of defect. Dimensions should be measured with slide calipers.												
3	Marking	To be easily legible.	The capacitor should be visually inspected.												
4	Dielectric Strength	Between Lead Wires	No failure. The capacitor should not be damaged when DC voltage of 200% of the rated voltage is applied between the lead wires for 1 to 5 sec. (Charge/Discharge current ≤ 50mA.)												
		Body Insulation	No failure. The capacitor is placed in the container with metal balls of diameter 1mm so that each lead wire, shortcircuited, is kept about 2mm off the metal balls as shown in the figure at right, and DC voltage of 1.3kV is applied for 1 to 5 sec. between capacitor lead wires and metal balls. (Charge/Discharge current ≤ 50mA.)												
5	Insulation Resistance (I.R.)	Between Lead Wires 10000MΩ min.	The insulation resistance should be measured with DC500±50V within 60±5 sec. of charging.												
6	Capacitance	Within specified tolerance.	The capacitance should be measured at 20°C with 1±0.2kHz and AC5V(r.m.s.) max.												
7	Dissipation Factor (D.F.)	Char. B, E: 2.5% max. Char. F: 5.0% max.	The dissipation factor should be measured at 20°C with 1±0.2kHz and AC5V(r.m.s.) max.												
8	Temperature Characteristics	Char. B: Within ±10% Char. E: Within +20/-55% Char. F: Within +30/-80%	The capacitance measurement should be made at each step specified in Table.												
		Pre-treatment : Capacitor should be stored at 85±2°C for 1 hr., then placed at *room condition for 24±2 hrs. before measurements.													
		<table border="1"> <thead> <tr> <th>Step</th> <th>1</th> <th>2</th> <th>3</th> <th>4</th> <th>5</th> </tr> </thead> <tbody> <tr> <td>Temp.(°C)</td> <td>20±2</td> <td>-25±3</td> <td>20±2</td> <td>85±2</td> <td>20±2</td> </tr> </tbody> </table>	Step	1	2	3	4	5	Temp.(°C)	20±2	-25±3	20±2	85±2	20±2	
Step	1	2	3	4	5										
Temp.(°C)	20±2	-25±3	20±2	85±2	20±2										
9	Strength of Lead	Pull	Lead wire should not be cut off. Capacitor should not be broken.												
		Bending													
			As shown in the figure at right, fix the body of the capacitor and apply a tensile weight gradually to each lead wire in the radial direction of the capacitor up to 10N (5N for lead diameter 0.5mm), and keep it for 10±1 sec.												
			Each lead wire should be subjected to 5N (2.5N for lead diameter 0.5mm) of weight and bent 90° at the point of egress, in one direction, then returned to its original position and bent 90° in the opposite direction at the rate of one bend in 2 to 3 sec.												
10	Vibration Resistance	Appearance	No marked defect.												
		Capacitance	Within specified tolerance.												
		D.F.	Char. B, E: 2.5% max. Char. F: 5.0% max.												
			The capacitor should be firmly soldered to the supporting lead wire and vibrated at a frequency range of 10 to 55Hz, 1.5mm in total amplitude, with about a 1 minute rate of vibration change from 10Hz to 55Hz and back to 10Hz. Apply for a total of 6 hrs., 2 hrs. each in 3 mutually perpendicular directions.												
11	Solderability of Leads	Lead wire should be soldered with uniform coating on the axial direction over 3/4 of the circumferential direction.	The lead wire of a capacitor should be dipped into a ethanol solution of 25wt% rosin and then into molten solder of 235±5°C for 2±0.5 sec. In both cases the depth of dipping is up to about 1.5 to 2mm from the root of lead wires.												
12	Soldering Effect	Appearance	No marked defect.												
		Capacitance Change	Char. B: Within ± 5% Char. E: Within ± 15% Char. F: Within ± 20%												
		Dielectric Strength (Between Lead Wires)	Per item 4.												
			The lead wire should be immersed into the melted solder of 350±10°C (Body of ø5mm and under: 270±5°C) up to about 1.5 to 2mm from the main body for 3.5±0.5 sec. (Body of ø5mm and under: 5±0.5 sec.) Pre-treatment : Capacitor should be stored at 85±2°C for 1 hr., then placed at *room condition for 24±2 hrs. before initial measurements. Post-treatment : Capacitor should be stored for 4 to 24 hrs. at *room condition.												

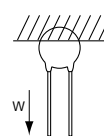
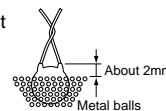

Continued on the following page.

Specifications and Test Methods

Continued from the preceding page.

No.	Item	Specifications	Testing Method
13	Temperature and Immersion Cycle	Appearance	No marked defect.
		Capacitance Change	Char. B: Within $\pm 10\%$ Char. E: Within $\pm 20\%$ Char. F: Within $\pm 30\%$
		D.F.	Char. B, E: 4.0% max. Char. F: 7.5% max.
		I.R.	2000M Ω min.
		Dielectric Strength (Between Lead Wires)	Per item 4.
14	Humidity (Under Steady State)	Appearance	No marked defect.
		Capacitance Change	Char. B: Within $\pm 10\%$ Char. E: Within $\pm 20\%$ Char. F: Within $\pm 30\%$
		D.F.	Char. B, E: 5.0% max. Char. F: 7.5% max.
		I.R.	1000M Ω min.
		Appearance	No marked defect.
15	Humidity Loading	Appearance	No marked defect.
		Capacitance Change	Char. B: Within $\pm 10\%$ Char. E: Within $\pm 20\%$ Char. F: Within $\pm 30\%$
		D.F.	Char. B, E: 5.0% max. Char. F: 7.5% max.
		I.R.	500M Ω min.
		Appearance	No marked defect.
16	Life	Appearance	No marked defect.
		Capacitance Change	Char. B: Within $\pm 10\%$ Char. E: Within $\pm 20\%$ Char. F: Within $\pm 30\%$
		D.F.	Char. B, E: 4.0% max. Char. F: 7.5% max.
		I.R.	2000M Ω min.
		Appearance	No marked defect.

* "room condition" Temperature: 15 to 35°C, Relative humidity: 45 to 75%, Atmospheric pressure: 86 to 106kPa

The capacitor should be subjected to 5 temperature cycles, then consecutively to 2 immersion cycles.

<Temperature cycle>

Step	Temperature(°C)	Time(min)
1	-25 ± 3	30
2	Room Temp.	3
3	85 ± 3	30
4	Room Temp.	3

Cycle time : 5 cycle

<Immersion cycle>

Step	Temperature(°C)	Time(min)	Immersion water
1	65 +5/-0	15	Clean water
2	0 ± 3	15	Salt water

Cycle time : 2 cycle

Pre-treatment : Capacitor should be stored at 85 $\pm 2^\circ\text{C}$ for 1 hr., then placed at *room condition for 24 ± 2 hrs. before initial measurements.

Post-treatment : Capacitor should be stored for 4 to 24 hrs. at *room condition.

Set the capacitor for 500 +24/-0 hrs. at 40 $\pm 2^\circ\text{C}$ in 90 to 95% relative humidity.

Pre-treatment : Capacitor should be stored at 85 $\pm 2^\circ\text{C}$ for 1 hr., then placed at *room condition for 24 ± 2 hrs. before initial measurements.

Post-treatment : Capacitor should be stored for 1 to 2 hrs. at *room condition.

Apply the rated voltage for 500 +24/-0 hrs. at 40 $\pm 2^\circ\text{C}$ in 90 to 95% relative humidity. (Charge/Discharge current $\leq 50\text{mA}$.)

Pre-treatment : Capacitor should be stored at 85 $\pm 2^\circ\text{C}$ for 1 hr., then placed at *room condition for 24 ± 2 hrs. before initial measurements.

Post-treatment : Capacitor should be stored at 85 $\pm 2^\circ\text{C}$ for 1 hr., then placed at *room condition for 24 ± 2 hrs.

Apply a DC voltage of 150% of the rated voltage for

1000 +48/-0 hrs. at 85 $\pm 2^\circ\text{C}$ with a relative humidity of 50% max. (Charge/Discharge current $\leq 50\text{mA}$.)

Pre-treatment : Capacitor should be stored at 85 $\pm 2^\circ\text{C}$ for 1 hr., then placed at *room condition for 24 ± 2 hrs. before initial measurements.

Post-treatment : Capacitor should be stored at 85 $\pm 2^\circ\text{C}$ for 1 hr., then placed at *room condition for 24 ± 2 hrs.

4

High Voltage Ceramic Capacitors (DC250V-6.3kV)



DEC Series (Class 1, 2/DC6.3kV)

■ Features

1. Coated with flame-retardant epoxy resin (equivalent to UL94V-0 standards).
2. We eliminated lead (Pb) from plating lead wires.

■ Applications

- Ideal for use as the ballast in backlighting inverters for liquid crystal displays (SL Char.).
- Ideal for use on high voltage circuits such as Cockcroft circuits (B Char.).

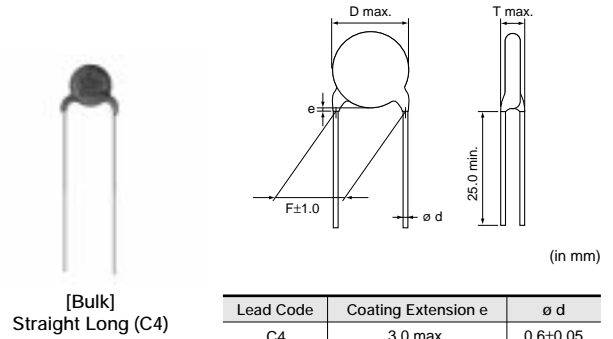

■ Marking

Temp. Char.	SL	B	E
Nominal body diameter			
ø8-9mm	47J 6KV 66	331K 6KV 66	_____
ø10-15mm	151J 6KV M 66	B 102K 6KV M 66	222Z 6KV M 66
Temperature Characteristics	Marked with code for char. B (omitted for nominal body diameter ø9mm and under)		
Nominal Capacitance	Under 100pF : Actual value, 100pF and over : Marked with 3 figures		
Capacitance Tolerance	Marked with code		
Rated Voltage	Marked with code (In case of DC6.3kV, marked with 6KV)		
Manufacturer's Identification	Marked with M (omitted for nominal body diameter ø9mm and under)		
Manufactured Date Code	Abbreviation		

SL Characteristics

Part Number	DC Rated Voltage (Vdc)	Capacitance (pF)	Body Dia. D (mm)	Lead Spacing F (mm)	Body Thickness T (mm)
DEC1X3J100JC4B	6300	10 +5,-5%	9	10.0	7.0
DEC1X3J120JC4B	6300	12 +5,-5%	8	10.0	7.0
DEC1X3J150JC4B	6300	15 +5,-5%	8	10.0	7.0
DEC1X3J180JC4B	6300	18 +5,-5%	9	10.0	7.0
DEC1X3J220JC4B	6300	22 +5,-5%	9	10.0	7.0
DEC1X3J270JC4B	6300	27 +5,-5%	9	10.0	7.0
DEC1X3J330JC4B	6300	33 +5,-5%	9	10.0	7.0
DEC1X3J390JC4B	6300	39 +5,-5%	9	10.0	7.0
DEC1X3J470JC4B	6300	47 +5,-5%	9	10.0	7.0
DEC1X3J560JC4B	6300	56 +5,-5%	10	10.0	7.0
DEC1X3J680JC4B	6300	68 +5,-5%	12	10.0	7.0
DEC1X3J820JC4B	6300	82 +5,-5%	12	10.0	7.0
DEC1X3J101JC4B	6300	100 +5,-5%	13	10.0	7.0
DEC1X3J121JC4B	6300	120 +5,-5%	14	10.0	7.0
DEC1X3J151JC4B	6300	150 +5,-5%	15	10.0	7.0

B Characteristics

Part Number	DC Rated Voltage (Vdc)	Capacitance (pF)	Body Dia. D (mm)	Lead Spacing F (mm)	Body Thickness T (mm)
DECB33J101KC4B	6300	100 +10,-10%	9	10.0	7.0
DECB33J151KC4B	6300	150 +10,-10%	9	10.0	7.0
DECB33J221KC4B	6300	220 +10,-10%	9	10.0	7.0
DECB33J331KC4B	6300	330 +10,-10%	9	10.0	7.0
DECB33J471KC4B	6300	470 +10,-10%	10	10.0	7.0
DECB33J681KC4B	6300	680 +10,-10%	11	10.0	7.0
DECB33J102KC4B	6300	1000 +10,-10%	13	10.0	7.0

E Characteristics

Part Number	DC Rated Voltage (Vdc)	Capacitance (pF)	Body Dia. D (mm)	Lead Spacing F (mm)	Body Thickness T (mm)
DECE33J102ZC4B	6300	1000 +80,-20%	11	10.0	7.0
DECE33J222ZC4B	6300	2200 +80,-20%	15	10.0	7.0

Specifications and Test Methods

No.	Item	Specifications	Testing Method												
1	Operating Temperature Range	-25 to +85°C													
2	Appearance and Dimensions	No marked defect on appearance form and dimensions are within specified range.	The capacitor should be visually inspected for evidence of defect. Dimensions should be measured with slide calipers.												
3	Marking	To be easily legible.	The capacitor should be visually inspected.												
4	Dielectric Strength	Between Lead Wires	No failure. The capacitor should not be damaged when DC voltage of 200% of the rated voltage is applied between the lead wires for 1 to 5 sec. (Charge/Discharge current ≤ 50mA.)												
		Body Insulation	No failure. The capacitor is placed in the container with metal balls of diameter 1mm so that each lead wire, shortcircuited, is kept about 2mm off the metal balls as shown in the figure at right, and DC voltage of 1.3kV is applied for 1 to 5 sec. between capacitor lead wires and metal balls. (Charge/Discharge current ≤ 50mA.)												
5	Insulation Resistance (I.R.)	Between Lead Wires 10000MΩ min.	The insulation resistance should be measured with DC500±50V within 60±5 sec. of charging.												
6	Capacitance	Within specified tolerance.	The capacitance should be measured at 20°C with 1±0.2kHz (Char. SL : 1±0.2MHz) and AC5V(r.m.s.) max.												
7	Q	Char. SL: 400+20C ^{*2} min. (30pF under) 1000 min. (30pF min.)	The dissipation factor and Q should be measured at 20°C with 1±0.2kHz (Char. SL : 1±0.2MHz) and AC5V(r.m.s.) max.												
	Dissipation Factor (D.F.)	Char. B, E: 2.5% max.													
8	Temperature Characteristics	Char. SL: +350 to -1000ppm/°C (Temp. range: +20 to +85°C) Char. B: Within ±10 % Char. E: Within +20/-55%	The capacitance measurement should be made at each step specified in Table.												
		Pre-treatment : Capacitor should be stored at 85±2°C for 1 hr., then placed at *1room condition for 24±2 hrs. before measurements. (Char. B, E)													
<table border="1" style="margin: auto; border-collapse: collapse;"> <thead> <tr> <th style="padding: 2px;">Step</th> <th style="padding: 2px;">1</th> <th style="padding: 2px;">2</th> <th style="padding: 2px;">3</th> <th style="padding: 2px;">4</th> <th style="padding: 2px;">5</th> </tr> </thead> <tbody> <tr> <td style="padding: 2px;">Temp.(°C)</td> <td style="padding: 2px;">20±2</td> <td style="padding: 2px;">-25±3</td> <td style="padding: 2px;">20±2</td> <td style="padding: 2px;">85±2</td> <td style="padding: 2px;">20±2</td> </tr> </tbody> </table>				Step	1	2	3	4	5	Temp.(°C)	20±2	-25±3	20±2	85±2	20±2
Step	1	2	3	4	5										
Temp.(°C)	20±2	-25±3	20±2	85±2	20±2										
9	Strength of Lead	Pull	Lead wire should not be cut off. Capacitor should not be broken. As shown in the figure at right, fix the body of the capacitor and apply a tensile weight gradually to each lead wire in the radial direction of the capacitor up to 10N and keep it for 10±1 sec.												
		Bending	Each lead wire should be subjected to 5N of weight and bent 90° at the point of egress, in one direction, then returned to its original position and bent 90° in the opposite direction at the rate of one bend in 2 to 3 sec.												
10	Vibration Resistance	Appearance	No marked defect.												
		Capacitance	Within specified tolerance.												
		Q	Char. SL: 400+20C ^{*2} min. (30pF under) 1000 min. (30pF min.)												
		D.F.	Char. B, E: 2.5% max.												
11	Solderability of Leads	Lead wire should be soldered with uniform coating on the axial direction over 3/4 of the circumferential direction.	The lead wire of a capacitor should be dipped into a ethanol solution of 25wt% rosin and then into molten solder of 235±5°C for 2±0.5 sec. In both cases the depth of dipping is up to about 1.5 to 2mm from the root of lead wires.												
12	Soldering Effect	Appearance	No marked defect.												
		Capacitance Change	Char. SL: Within ±2.5% Char. B: Within ±5% Char. E: Within ±15%												
		Dielectric Strength (Between Lead Wires)	Per item 4.												
		The lead wire should be immersed into the melted solder of 350±10°C up to about 1.5 to 2mm from the main body for 3.5±0.5 sec. Pre-treatment : Capacitor should be stored at 85±2°C for 1 hr., then placed at *1room condition for 24±2 hrs. before initial measurements. (Char. B, E) Post-treatment : Capacitor should be stored for 1 to 2 hrs. at *1room condition. (Char. SL) Post-treatment : Capacitor should be stored for 4 to 24 hrs. at *1room condition. (Char. B, E)													

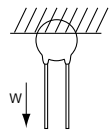
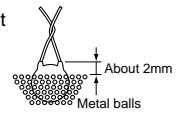

5

*1 "room condition" Temperature: 15 to 35°C, Relative humidity: 45 to 75%, Atmospheric pressure: 86 to 106kPa

*2 "C" expresses nominal capacitance value (pF)

Continued on the following page.

Specifications and Test Methods

Continued from the preceding page.

No.	Item	Specifications	Testing Method
13	Temperature and Immersion Cycle	Appearance	No marked defect.
		Capacitance Change	Char. SL: Within $\pm 3\%$ Char. B: Within $\pm 10\%$ Char. E: Within $\pm 20\%$
		Q	Char. SL: $275+5/2C^{*2}$ min. (30pF under) 350 min. (30pF min.)
		D.F.	Char. B, E: 4.0% max.
		I.R.	2000M Ω min.
		Dielectric Strength (Between Lead Wires)	Per item 4.
14	Humidity (Under Steady State)	Appearance	No marked defect.
		Capacitance Change	Char. SL: Within $\pm 5\%$ Char. B: Within $\pm 10\%$ Char. E: Within $\pm 20\%$
		Q	Char. SL: $275+5/2C^{*2}$ min. (30pF under) 350 min. (30pF min.)
		D.F.	Char. B, E: 5.0% max.
		I.R.	1000M Ω min.
15	Humidity Loading	Appearance	No marked defect.
		Capacitance Change	Char. SL: Within $\pm 7.5\%$ Char. B: Within $\pm 10\%$ Char. E: Within $\pm 20\%$
		Q	Char. SL: $100+10/3C^{*2}$ min. (30pF under) 200 min. (30pF min.)
		D.F.	Char. B, E: 5.0% max.
		I.R.	500M Ω min.
16	Life	Appearance	No marked defect.
		Capacitance Change	Char. SL: Within $\pm 3\%$ Char. B: Within $\pm 10\%$ Char. E: Within $\pm 20\%$
		Q	Char. SL: $275+5/2C^{*2}$ min. (30pF under) 350 min. (30pF min.)
		D.F.	Char. B, E: 4.0% max.
		I.R.	2000M Ω min.

The capacitor should be subjected to 5 temperature cycles, then consecutively to 2 immersion cycles.

<Temperature cycle>

Step	Temperature(°C)	Time(min)
1	-25 \pm 3	30
2	Room Temp.	3
3	85 \pm 3	30
4	Room Temp.	3

Cycle time : 5 cycle

<Immersion cycle>

Step	Temperature(°C)	Time(min)	Immersion water
1	65 +5/-0	15	Clean water
2	0 \pm 3	15	Salt water

Cycle time : 2 cycle

Pre-treatment : Capacitor should be stored at 85 \pm 2°C for 1 hr., then placed at *1room condition for 24 \pm 2 hrs. before initial measurements. (Char. B, E)
Post-treatment : Capacitor should be stored for 4 to 24 hrs. at *1room condition.

Set the capacitor for 500 +24/-0 hrs. at 40 \pm 2°C in 90 to 95% relative humidity.
Pre-treatment : Capacitor should be stored at 85 \pm 2°C for 1 hr., then placed at *1room condition for 24 \pm 2 hrs. before initial measurements. (Char. B, E)
Post-treatment : Capacitor should be stored for 1 to 2 hrs. at *1room condition.

Apply the rated voltage for 500 +24/-0 hrs. at 40 \pm 2°C in 90 to 95% relative humidity. (Charge/Discharge current \leq 50mA.)
Pre-treatment : Capacitor should be stored at 85 \pm 2°C for 1 hr., then placed at *1room condition for 24 \pm 2 hrs. before initial measurements. (Char. B, E)
Post-treatment : Capacitor should be stored for 1 to 2 hrs. at *1room condition. (Char. SL)
Post-treatment : Capacitor should be stored at 85 \pm 2°C for 1 hr., then placed at *1room condition for 24 \pm 2 hrs. (Char. B, E)

Apply a DC voltage of 150% of the rated voltage for 1000 +48/-0 hrs. at 85 \pm 2°C with a relative humidity of 50% max. (Charge/Discharge current \leq 50mA.)
Pre-treatment : Capacitor should be stored at 85 \pm 2°C for 1 hr., then placed at *1room condition for 24 \pm 2 hrs. before initial measurements. (Char. B, E)
Post-treatment : Capacitor should be stored for 1 to 2 hrs. at *1room condition. (Char. SL)
Post-treatment : Capacitor should be stored at 85 \pm 2°C for 1 hr., then placed at *1room condition for 24 \pm 2 hrs. (Char. B, E)

*1 "room condition" Temperature: 15 to 35°C, Relative humidity: 45 to 75%, Atmospheric pressure: 86 to 106kPa

*2 "C" expresses nominal capacitance value (pF)

Characteristics Data (Typical Example)

■ Capacitance-Temperature Characteristics

B, E, F, SL char.

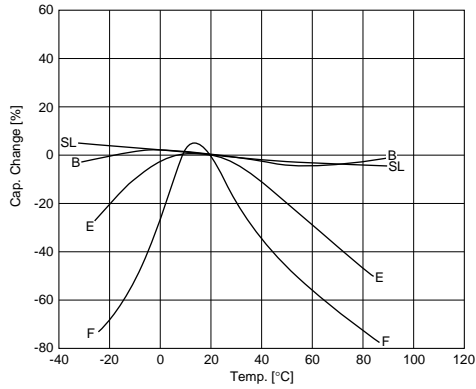

C, D, R char.

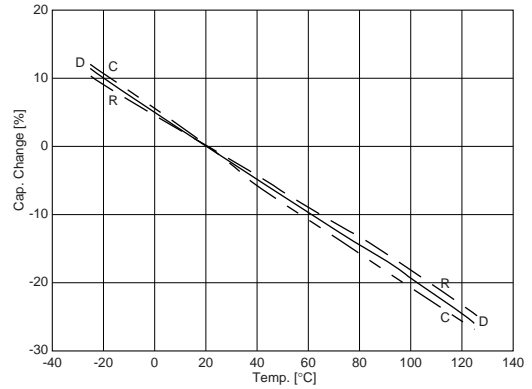

■ Capacitance-DC Bias Characteristics

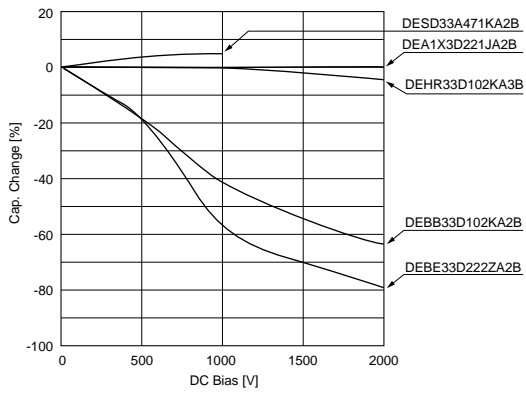

Packaging

■ Taping Specification

- 15.0mm pitch/lead spacing 7.5mm taping
Straight type
(Lead Code : P3)

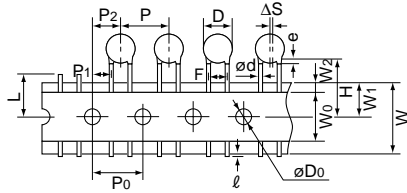

- 15.0mm pitch/lead spacing 7.5mm taping
Vertical crimp type
(Lead Code : N3)

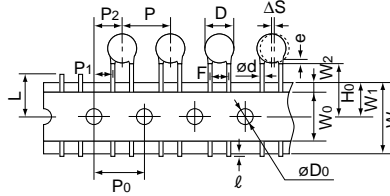

- 30.0mm pitch/lead spacing 7.5mm taping
Vertical crimp type
(Lead Code : N7)

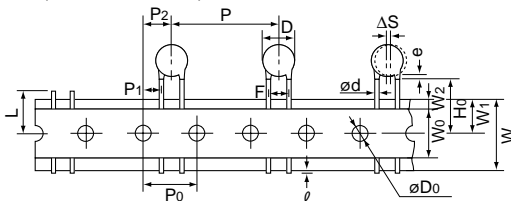

- 12.7mm pitch/lead spacing 5.0mm taping
Straight type
(Lead Code : P2)

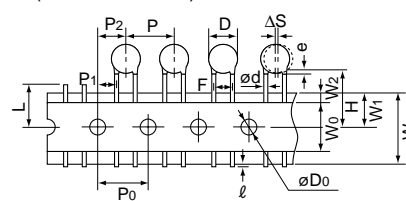

- 12.7mm pitch/lead spacing 5.0mm taping
Vertical crimp type
(Lead Code : N2)

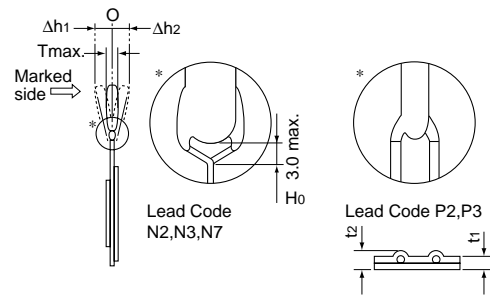
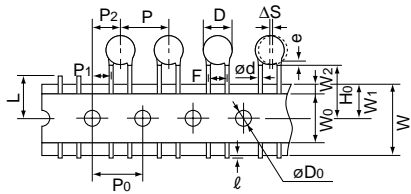

Item	Code	P3	N3	N7	P2	N2
Pitch of component	P	15.0		30.0	12.7	
Pitch of sprocket hole	P0	15.0±0.3			12.7±0.3	
Lead spacing	F	7.5±1.0			5.0 ^{+0.8} _{-0.2}	
Length from hole center to component center	P2	7.5±1.5			6.35±1.3	
Length from hole center to lead	P1	3.75±1.0			3.85±0.7	
Body diameter	D	See the individual product specification				
Deviation along tape, left or right	ΔS	0±2.0			0±1.0	
Carrier tape width	W	18.0±0.5				
Position of sprocket hole	W1	9.0±0.5				
Lead distance between reference and bottom planes	H	20.0 ^{+1.5} _{-1.0}		—	20.0 ^{+1.5} _{-1.0}	—
	H0	—	18.0 ^{+2.0} ₋₀		—	18.0 ^{+2.0} ₋₀
Protrusion length	ℓ	+0.5 to -1.0				
Diameter of sprocket hole	φD0	4.0±0.1				
Lead diameter	φd	0.6±0.05				
Total tape thickness	t1	0.6±0.3				
Total thickness, tape and lead wire	t2	1.5 max.				
Body thickness	T	See the individual product specification				
Portion to cut in case of defect	L	11.0 ⁺⁰ _{-1.0}				
Hold down tape width	W0	11.5 min.				
Hold down tape position	W2	1.5±1.5				
Coating extension on lead	e	3.0 max. (Vertical crimp type : Up to the end of crimp)				
Deviation across tape	Δh1	2.0 max.			1.0 max.	
	Δh2					

(in mm)

Continued on the following page. ↗

Packaging

☒ Continued from the preceding page.

■ Packaging Styles

Bulk	Taping
Polyethylene Bag 	Ammo Pack 

■ Minimum Quantity (Order in Sets Only)

[Bulk] 1,000 pcs.

[Taping]

1,500 pcs. (Lead Code : P2,N2)

1,000 pcs. (Lead Code : P3, N3*)

500 pcs. (Lead Code : N7)

* 900 pcs. for 2kV and 3.15kV

■ Minimum Order Quantity

[Bulk] 3,000 pcs.

[Taping]

3,000 pcs. (Lead Code : P2,N2)

3,000 pcs. (Lead Code : P3, N3*)

2,000 pcs. (Lead Code : N7)

* 2,700 pcs. for 2kV and 3.15kV

"Minimum Quantity" means the numbers of units of each delivery or order. The quantity should be an integral multiple of the "minimum quantity". (Please note that the actual delivery quantity in a package may change sometimes.)

⚠Caution

■ ⚠Caution (Rating)

1. Operating Voltage

When DC-rated capacitors are to be used in AC or ripple current circuits, be sure to maintain the V_{p-p} value of the applied voltage or the V_{o-p} which contains DC bias within the rated voltage range.

When the voltage is applied to the circuit, starting or stopping may generate irregular voltage for a transit period because of resonance or switching. Be sure to use a capacitor with a rated voltage range that includes these irregular voltages.

When using the low-dissipation DEA (SL Char.) /DEH (C, R Char.) /DES (D Char.) series in a high-frequency and high-voltage circuit, be sure to read the instructions in item 4.

Voltage	DC Voltage	DC+AC Voltage	AC Voltage	Pulse Voltage (1)	Pulse Voltage (2)
Positional measurement					

2. Operating Temperature and Self-generated Heat

Keep the surface temperature of a capacitor below the upper limit of its rated operating temperature range. Be sure to take into account the heat generated by the capacitor itself. When the capacitor is used in a high-frequency current, pulse current or similar current, it may self-generate heat due to dielectric loss. The frequency of the applied sine wave voltage should be less than 300kHz. The applied voltage load (*) should be such that the capacitor's self-generated heat is within 20°C at an atmosphere temperature of 25°C. When measuring, use a thermocouple of small thermal capacity-K of $\varnothing 0.1\text{mm}$ in conditions where the capacitor is not affected by radiant heat from other components or surrounding ambient fluctuations.

Excessive heat may lead to deterioration of the capacitor's characteristics and reliability.

(Never attempt to perform measurement with the cooling fan running. Otherwise, accurate measurement cannot be ensured.)

*Before using the low-dissipation DEA/DEH/DES series, be sure to read the instructions in item 4.

3. Fail-Safe

When capacitor is broken, failure may result in a short circuit. Be sure to provide an appropriate fail-safe function like a fuse on your product if failure would follow an electric shock, fire or fume.

Continued on the following page.

Caution

Continued from the preceding page.

4. Load Reduction and Self-generated Heat During Application of High-frequency and High-voltage
Due to the low self-heating characteristics of low-dissipation capacitors, the allowable electric power of these capacitors is generally much higher than that of B characteristic capacitors. However, in case the self-heating temperature is 20°C under a high-frequency voltage whose peak-to-peak value equals the capacitor's rated voltage, the capacitor's power consumption may exceed its allowable electric power.
Therefore, when using the DEA/DEH/DES series in a high-frequency and high-voltage circuit with a frequency of 1kHz or higher, make sure that the Vp-p values including the DC bias, do not exceed the applied voltage value specified in Table 1. Also make sure that the self-heating temperature (the difference between the capacitor's surface temperature and the capacitor's ambient temperature) at an ambient temperature of 25°C does not exceed the value specified in Table 1.
As shown in Fig. 2, the self-heating temperature depends on the ambient temperature. Therefore, if you are not able to set the ambient temperature to approximately 25°C, please contact our sales representatives or product engineers.

We are offering free software the "capacitor selection tool: Murata Medium-voltage Capacitors Selection Tool by Voltage Form (*)" which will assist you in selecting a suitable capacitor.
The software can be downloaded from Murata's Internet Web site.
(http://www.murata.com/designlib/mmcsv_e.html)
By inputting capacitance values and applied voltage waveform of the specific capacitor series, this software will calculate the capacitor's power consumption and list suitable capacitors.
When the result of this software is different from the measurement result of the self-heating temperature on your side, please contact our sales representatives or product engineers.

* As of Feb. 2003, subject series are below.

- DEA/DEH Series: Selection currently available.
- DES Series: Currently in developing stage.

Failure to follow the above cautions (items 1 to 4) may result, worst case, in a short circuit and cause fuming or partial dispersion when the product is used.

<Table 1> Allowable Conditions at High-frequency

Series	Temp. Char.	DC Rated Voltage	Allowable Conditions at High-frequency *3		Capacitor's Ambient Temp. *2
			Applied Voltage (Max.)	Self-heating Temp. (25°C Ambient Temp.) *1	
DEH	R	250V	250Vp-p	10°C Max.	-25 to +85°C
	C	500V	500Vp-p	20°C Max.	
	R	1kV	800Vp-p	20°C Max.	
			1000Vp-p	5°C Max.	
		2kV	1400Vp-p	20°C Max.	
			2000Vp-p	5°C Max.	
3.15kV	1600Vp-p	20°C Max.			
	3150Vp-p	5°C Max.			
DEA	SL	1kV	1000Vp-p	5°C Max.	
		2kV	2000Vp-p		
		3.15kV	3150Vp-p		
DES	D	500V	500Vp-p	15°C Max.	
		1kV	800Vp-p		
			1000Vp-p	5°C Max.	

*1 Fig. 1 shows the relationship between the applied voltage and the allowable self-heating temperature regarding 1 to 3.15kV rated voltage of the DEH series R characteristic and 1kV rated voltage of the DES series D characteristic.

*2 When the ambient temperature is 85 to 125°C, the applied voltage needs to be further reduced. If the DEA/DEH/DES series needs to be used at an ambient temperature of 85 to 125°C, please contact our sales representatives or product engineers.

*3 Fig. 3 shows reference data on the allowable voltage-frequency characteristic for a sine wave voltage.

<Fig. 1> Relationship Between Applied Voltage and Self-heating Temperature (Allowable Self-heating Temp. at 25°C Ambient Temp.)

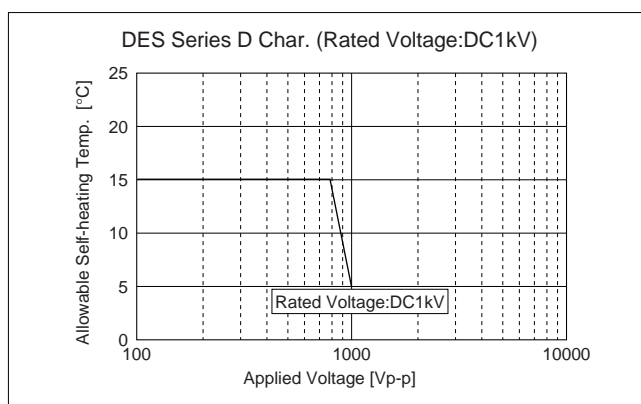
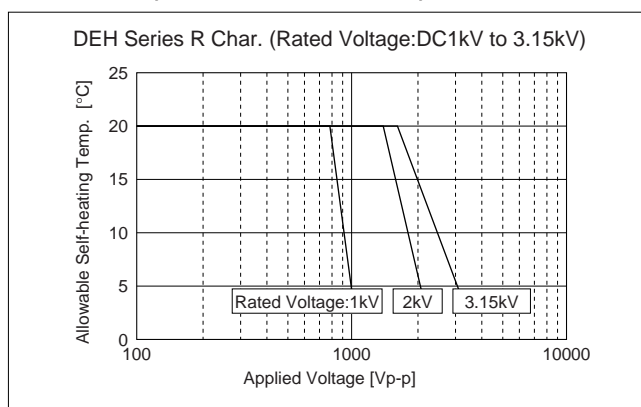

Continued on the following page. ↗



↳ Continued from the preceding page.

<Fig. 2> Dependence of Self-heating Temperature on Ambient Temperature

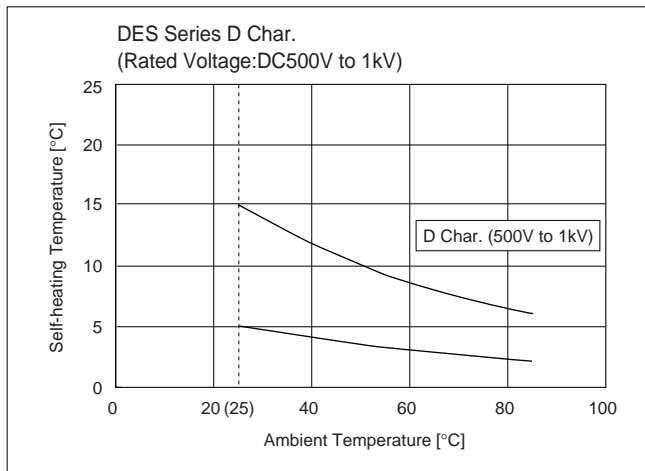
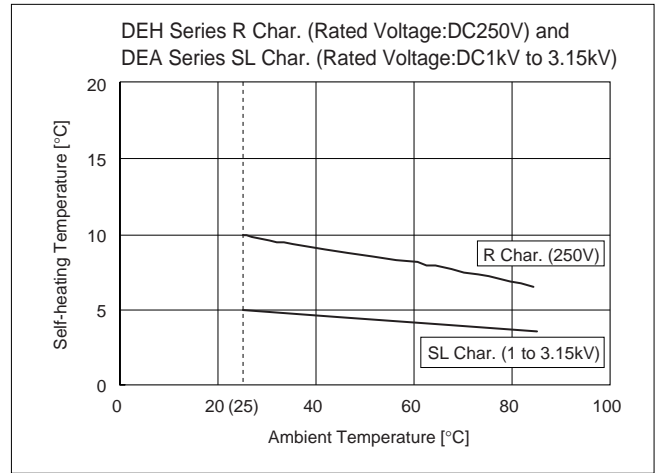
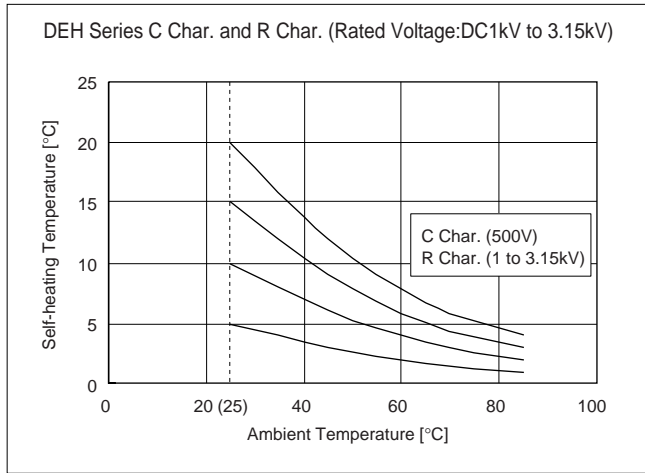

Continued on the following page. ↗

⚠Caution

↳ Continued from the preceding page.

<Fig. 3> Allowable Voltage (Sine Wave Voltage) - Frequency Characteristics (At Ambient Temperature of 85°C or less)

Because of the influence of harmonics, when the applied voltage is a rectangular wave or pulse wave voltage (instead of a sine wave voltage), the heat generated by the capacitor is higher than the value obtained by application of the sine wave with the same fundamental frequency.

Roughly calculated for reference, the allowable voltage for a rectangular wave or pulse wave corresponds approximately

to the allowable voltage for a sine wave whose fundamental frequency is twice as large as that of the rectangular wave or pulse wave. This allowable voltage, however, varies depending on the voltage and current waveforms.

Therefore, you are requested to make sure that the self-heating temperature is not higher than the value specified in Table 1.

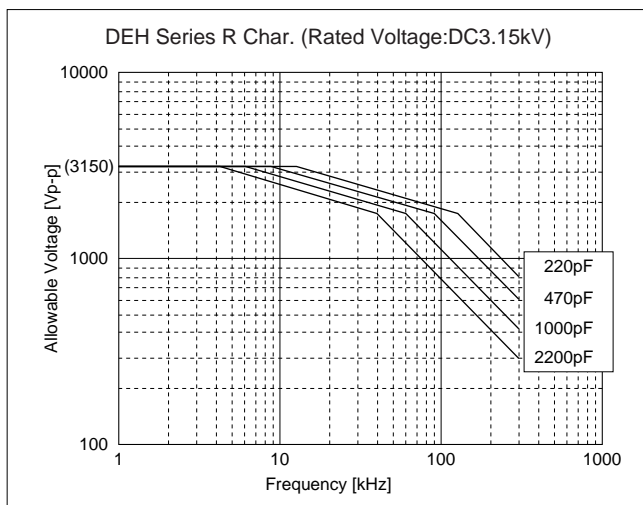
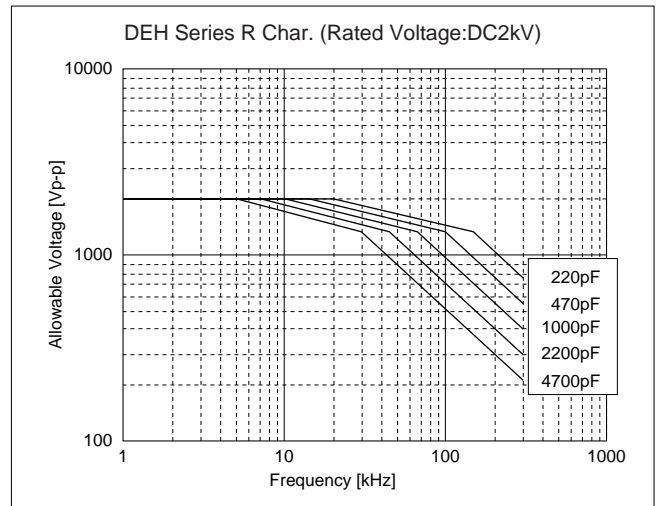
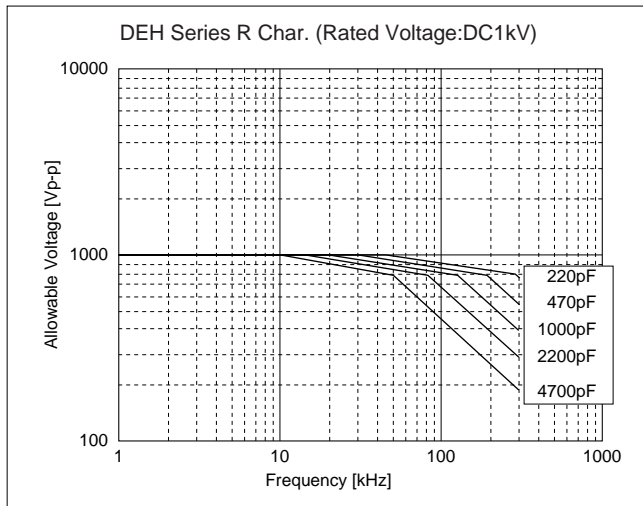
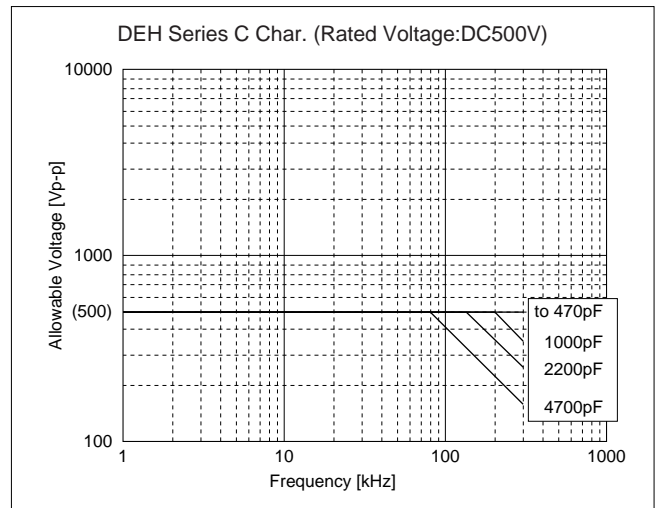
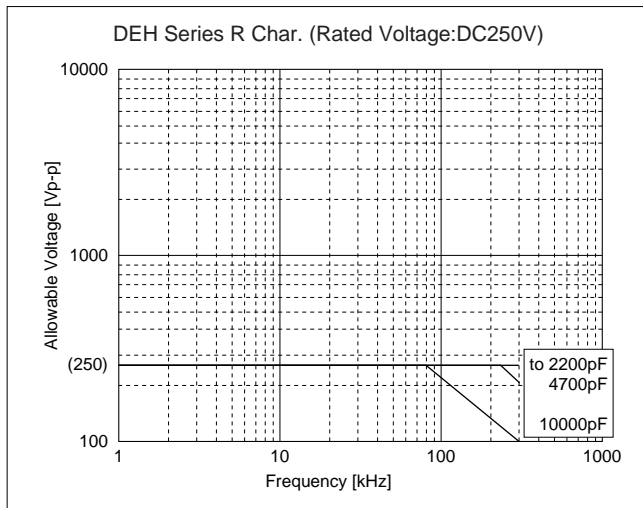

Continued on the following page. ↗



☐ Continued from the preceding page.

<Fig. 3 (continue)> Allowable Voltage (Sine Wave Voltage) - Frequency Characteristics (At Ambient Temperature of 85°C or less)

Because of the influence of harmonics, when the applied voltage is a rectangular wave or pulse wave voltage (instead of a sine wave voltage), the heat generated by the capacitor is higher than the value obtained by application of the sine wave with the same fundamental frequency.

Roughly calculated for reference, the allowable voltage for a rectangular wave or pulse wave corresponds

approximately to the allowable voltage for a sine wave whose fundamental frequency is twice as large as that of the rectangular wave or pulse wave.

This allowable voltage, however, varies depending on the voltage and current waveforms.

Therefore, you are requested to make sure that the self-heating temperature is not higher than the value specified in Table 1.

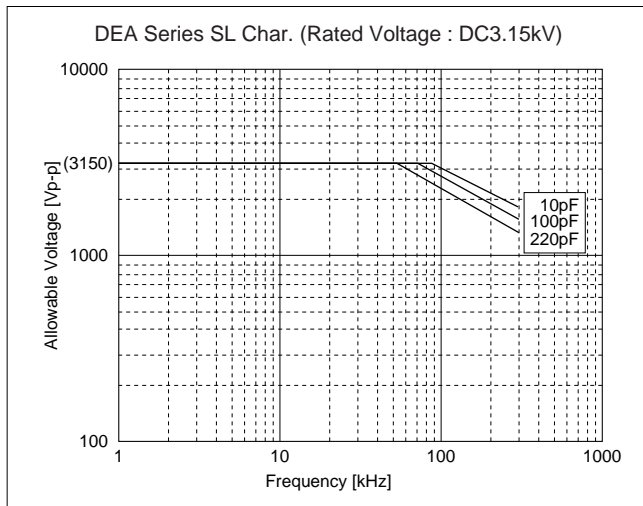
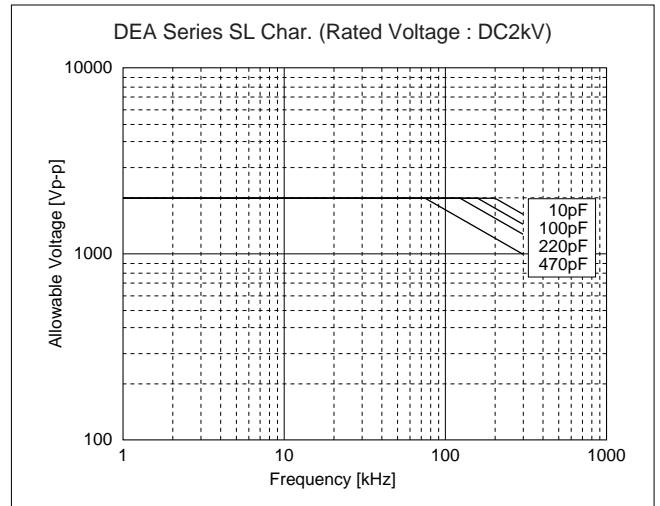
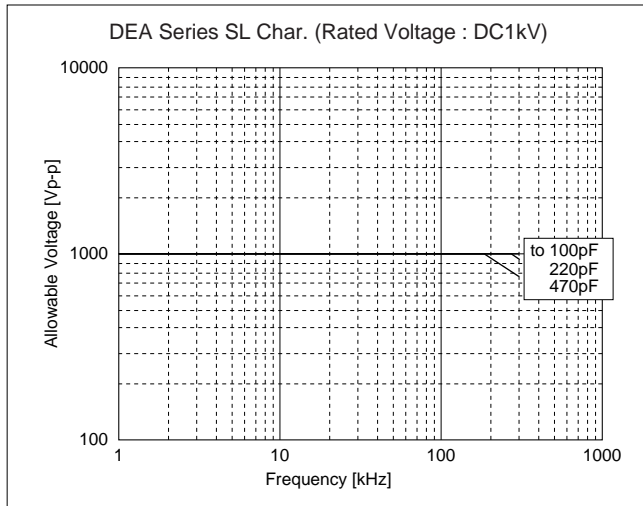

Continued on the following page. ☐

⚠Caution

↳ Continued from the preceding page.

<Fig. 3 (continue)> Allowable Voltage (Sine Wave Voltage) - Frequency Characteristics (At Ambient Temperature of 85°C or less)

Because of the influence of harmonics, when the applied voltage is a rectangular wave or pulse wave voltage (instead of a sine wave voltage), the heat generated by the capacitor is higher than the value obtained by application of the sine wave with the same fundamental frequency.

Roughly calculated for reference, the allowable voltage for a rectangular wave or pulse wave corresponds

approximately to the allowable voltage for a sine wave whose fundamental frequency is twice as large as that of the rectangular wave or pulse wave.

This allowable voltage, however, varies depending on the voltage and current waveforms.

Therefore, you are requested to make sure that the self-heating temperature is not higher than the value specified in Table 1.

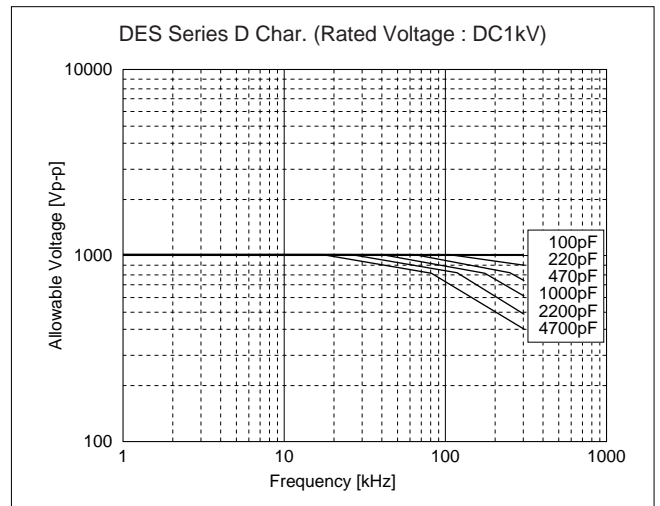
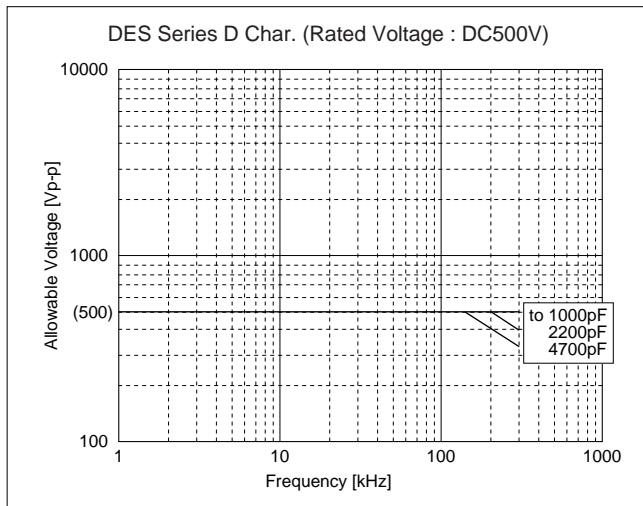

⚠Caution

■ ⚠Caution (Storage and operating condition)

Operating and storage environment

The insulating coating of capacitors does not form a perfect seal; therefore, do not use or store capacitors in a corrosive atmosphere, especially where chloride gas, sulfide gas, acid, alkali, salt or the like are present. And avoid exposure to moisture. Before cleaning, bonding or molding this product, verify that these processes do not affect product quality by testing the performance of a

cleaned, bonded or molded product in the intended equipment. Store the capacitors where the temperature and relative humidity do not exceed -10 to 40 degrees centigrade and 15 to 85 %.

Use capacitors within 6 months.

FAILURE TO FOLLOW THE ABOVE CAUTIONS MAY RESULT, WORST CASE, IN A SHORT CIRCUIT AND CAUSE FUMING OR PARTIAL DISPERSION WHEN THE PRODUCT IS USED.

■ ⚠Caution (Soldering and Mounting)

1. Vibration and impact

Do not expose a capacitor or its leads to excessive shock or vibration during use.

2. Soldering

When soldering this product to a PCB/PWB, do not exceed the solder heat resistance specification of the capacitor. Subjecting this product to excessive heating could melt the internal junction solder and may result in thermal shocks that can crack the ceramic element.

When soldering capacitor with a soldering iron, it should be performed in following conditions.

Temperature of iron-tip: 400 degrees C. max.

Soldering iron wattage : 50W max.

Soldering time : 3.5 sec. max.

FAILURE TO FOLLOW THE ABOVE CAUTIONS MAY RESULT, WORST CASE, IN A SHORT CIRCUIT AND CAUSE FUMING OR PARTIAL DISPERSION WHEN THE PRODUCT IS USED.

■ ⚠Caution (Handling)

Vibration and impact

Do not expose a capacitor or its leads to excessive shock or vibration during use.

FAILURE TO FOLLOW THE ABOVE CAUTIONS MAY RESULT, WORST CASE, IN A SHORT CIRCUIT AND CAUSE FUMING OR PARTIAL DISPERSION WHEN THE PRODUCT IS USED.

Notice / ISO9000 Certifications

■ Notice (Soldering and Mounting)

Cleaning (ultrasonic cleaning)

To perform ultrasonic cleaning, observe the following conditions.

Rinse bath capacity : Output of 20 watts per liter or less.

Rinsing time : 5 min. maximum.

Do not vibrate the PCB/PWB directly.

Excessive ultrasonic cleaning may lead to fatigue destruction of the lead wires.

■ Notice (Rating)

Capacitance change of capacitor

1. DEA/DEC series (Temp. Char. SL)

Capacitance might change a little depending on the surrounding temperature or an applied voltage.

Please contact us if you intend to use this product in a strict time constant circuit.

2. DEB/DEC series (Temp. Char. B, E, F)

Capacitors have an aging characteristic, whereby the capacitor continually decreases its capacitance slightly if the capacitor is left on for a long time. Moreover, capacitance might change

greatly depending on the surrounding temperature or an applied voltage. So, it is not likely to be suitable for use in a time constant circuit.

Please contact us if you need detailed information.

3. DEH/DES series

Capacitance might change greatly depending on the surrounding temperature or an applied voltage.

So, it is not likely to be suitable for use in a time constant circuit. Please contact us if you need detailed information.

■ ISO9000 Certifications

Manufacturing plants which produce the products in this catalog have obtained the ISO9000 quality system certificate.

Plant	Certified Date	Organization	Registration No.	Applied standard
Izumo Murata Manufacturing Co., Ltd.	Feb. 1. '00	Underwriters Laboratories Inc.	A5587	ISO9001
Murata Electronics (Thailand), Ltd.	Apr. 8. '02	Underwriters Laboratories Inc.	A6279	ISO9001
Taiwan Murata Electronics Co., Ltd.	Nov. 26. '93	BUREAU OF STANDARDS, METROLOGY AND INSPECTION	5E8Y001	ISO9002

⚠Note:

1. Export Control

⟨For customers outside Japan⟩

Murata products should not be used or sold for use in the development, production, stockpiling or utilization of any conventional weapons or mass-destructive weapons (nuclear weapons, chemical or biological weapons, or missiles), or any other weapons.

⟨For customers in Japan⟩

For products which are controlled items subject to the "Foreign Exchange and Foreign Trade Law" of Japan, the export license specified by the law is required for export.

2. Please contact our sales representatives or product engineers before using the products in this catalog for the applications listed below, which require especially high reliability for the prevention of defects which might directly damage to a third party's life, body or property, or when one of our products is intended for use in applications other than those specified in this catalog.

- | | |
|-----------------------------|---|
| ① Aircraft equipment | ② Aerospace equipment |
| ③ Undersea equipment | ④ Power plant equipment |
| ⑤ Medical equipment | ⑥ Transportation equipment (vehicles, trains, ships, etc.) |
| ⑦ Traffic signal equipment | ⑧ Disaster prevention / crime prevention equipment |
| ⑨ Data-processing equipment | ⑩ Application of similar complexity and/or reliability requirements to the applications listed in the above |

3. Product specifications in this catalog are as of April 2003. They are subject to change or our products in it may be discontinued without advance notice. Please check with our sales representatives or product engineers before ordering. If there are any questions, please contact our sales representatives or product engineers.

4. Please read rating and ⚠CAUTION (for storage, operating, rating, soldering, mounting and handling) in this catalog to prevent smoking and/or burning, etc.

5. This catalog has only typical specifications because there is no space for detailed specifications. Therefore, please approve our product specifications or transact the approval sheet for product specifications before ordering.

6. Please note that unless otherwise specified, we shall assume no responsibility whatsoever for any conflict or dispute that may occur in connection with the effect of our and/or a third party's intellectual property rights and other related rights in consideration of your use of our products and/or information described or contained in our catalogs. In this connection, no representation shall be made to the effect that any third parties are authorized to use the rights mentioned above under licenses without our consent.

7. No ozone depleting substances (ODS) under the Montreal Protocol are used in our manufacturing process.