

KEMET®



Sierra-KD
High Temperature
and High Voltage
Ceramic Capacitors

GBS
405K
200V
0319

HS24B
123MS
3KV
0423KEC

103K
2000V
0321
GBS

102K
10KV
KEC
0420

GBS
101K
500V
0320

104K
50V
0322

333K
1KV
0415KEC

General Performance Characteristics	2-4
--	-----

High Temperature Ceramic Capacitors

HT/HP - Standard Series - (+200°C) Ceramic Capacitors C0G (NP0), X7R Dielectric	5
HV-High Voltage Series - (+200°C) Ceramic Capacitors C0G (NP0), X7R Dielectric	6
Ceramic Cased Capacitors C ³ General Information	7
SCR/SCA Standard Axial & Radial Ceramic Capacitors - C0G (NP0) Dielectric	8-9
SRR/SRA Standard Axial & Radial Ceramic Capacitors - X7R Dielectric	8-10
ACR/ACA High Temperature (+200°C) Axial & Radial Ceramic Capacitors - C0G (NP0) Dielectric	11-12
ARR/ARA High Temperature (+200°C) Axial & Radial Ceramic Capacitors - X7R Dielectric	11-13
TCR/TCA High Temperature (+260°C) Axial & Radial Ceramic Capacitors - C0G (NP0) Dielectric	14-15
TRR/TRA High Temperature (+260°C) Axial & Radial Ceramic Capacitors - X7R Dielectric	14-16
VCR - C ³ High Temperature/High Voltage (+260°C) Axial & Radial Ceramic Capacitors - C0G (NP0) Dielectric	17-18
VRR - C ³ High Temperature/High Voltage (+260°C) Axial & Radial Ceramic Capacitors - X7R Dielectric	17-19

High Voltage Ceramic Capacitors

Performance Characteristics	20
HV Series, High Voltage, Radial Conformally Coated, KDA, C0G (NP0), X7R Dielectric	20-21
HV Series, High Voltage, Radial Conformally Coated, C0G (NP0) & X7R Dielectric (MIL-PRF-49467 Equivalent)	22-23
HS Series, High Voltage, Radial Conformally Coated, Space Quality, C0G (NP0) & X7R Dielectric	24-25
High Voltage, Ceramic Chip Military Equivalent Tested - C0G (NP0), X7R Dielectric	26-27
High Voltage, Ceramic Chip Commercial - C0G (NP0), X7R, KDA Dielectric	28-31
SM Series, High Voltage Surface Mount Ceramic Chip - C0G (NP0), X7R Dielectric	32-33
D Series, High Voltage Surface Mount Ceramic Disc - C0G (NP0), X7R, X5U Dielectric	34-35
High Voltage Disc Multilayer Stacks - C0G (NP0), X7R, X5U Dielectric	36

DIELECTRIC COMPARISONS

Features	Ultra Stable	Semi-Stable Low DF	Semi-Stable High Voltage	Semi-Stable Hi-Temp	Temp/Volt Dependent
Dielectric Type	C0G (NPO)	KDA	X7R	X7R type	X5U
Temperature Coefficient	0 ±30ppm/°C	+21/-24%	±15%	+15/-40%	+22-56%
Operating Temp. Range	-55 to +200°C	-55 to +115°C	-55 to +125°C	-55 to +200°C	-55 to +125°C
Dissipation Factor	0.1% max.	0.2% max.	2.5% max.	2.0% max.	2.5% max.
Aging Rate	None	None	-2.0% max/dec. hour	-2.0% max/dec. hour	-2.0% max/dec. hour
Voltage Range	25 to 20k VDC	50 to 10k VDC	50 to 50k VDC	25 to 4k VDC	Up to 20K VDC
Standard Tolerance	J, K, M	K, M, P, Z	K, M, P, Z	K, M, P, Z	M, P, Z
Coefficient of Thermal Expansion @ 25°C	9 X 10 ⁻⁶ IN/IN °C	9 X 10 ⁻⁶ IN/IN °C	11 X 10 ⁻⁶ IN/IN °C	11 X 10 ⁻⁶ IN/IN °C	11 X 10 ⁻⁶ IN/IN °C

Typical Temperature Coefficients of Capacitance

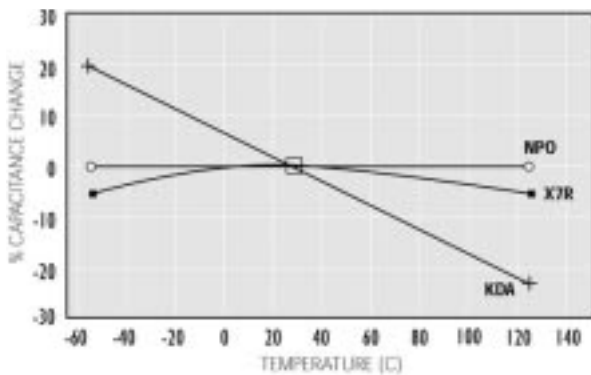

Typical Dissipation Factor vs. Temperature

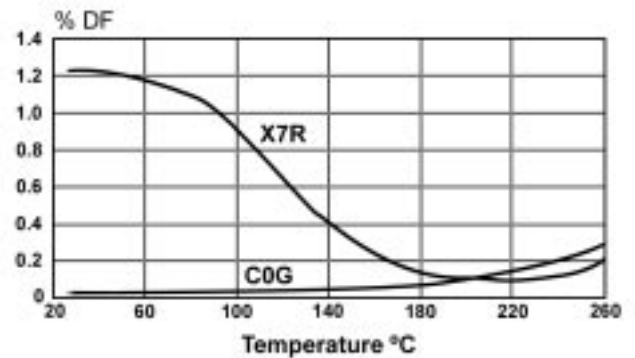

Typical Dissipation Factor vs. Frequency

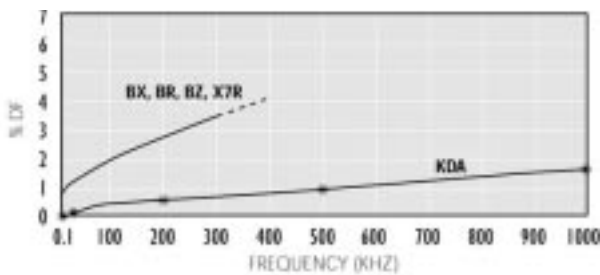

Typical Insulation Resistance vs. Temperature C0G (NPO) & X7R Dielectric

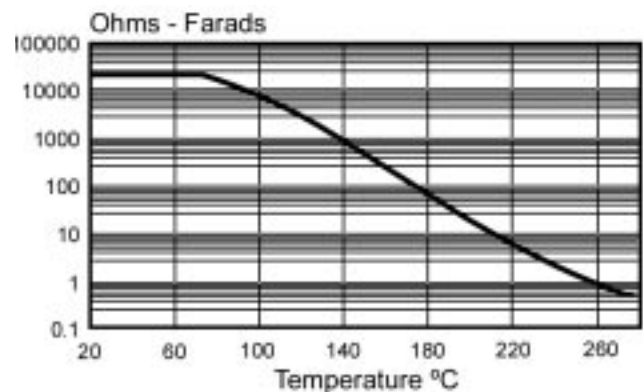

	HIGH TEMPERATURE	HIGH VOLTAGE
MILITARY & AEROSPACE		
Avionics	X	X
Radar Systems	X	X
Telemetry, Data Tx/Rx		X
Control Systems	X	
MEDICAL		
.5 to 1.5 Tesla MR1 &		X
NM1 Tuning Coils		X
1 to 3 Tesla MR1 Gradient		X
Coils & Magnetic Rings		X
CT-Scanner		X
Medical MRI		X
X-Ray Generator	X	X
SEMICONDUCTOR		
RF Tuning Networks		X
RF Power Supplies		X
Semiconductor Manufacturing	X	
SECURITY		
Handheld Scanners		X
Intruder Detection Systems		X
Luggage Scanners		X
Metal/Explosive Detector		X
OTHER		
LCD Backlight Inverter		X
Electric Ballast for CFL	X	X
Electric Ballast for Fluorescent Lamp	X	X
Measurement Equipment	X	X
Microwave/Convection Ovens	X	X
POWER SUPPLY		
HV Power Supply	X	X
Power Station Equipment		X
Power Supply for Air Conditioner, Washing Machine		X
Inverter Power Supply-AC	X	
TELECOM		
Base Station Power amps		X
Broadcasting Equipment		X
MODEM		
DAA Modem		X
xDSL Modem		X
LAN, Router, HUB, Switches		X
RF Power Amplifiers		X
INDUSTRIAL		
Oil Rigging, Down Hole, Mining	X	X

	ELECTRICAL			ENVIRONMENTAL	MECHANICAL	CATALOG
	Voltage Range	Capacitance Range	Dissipation Factor	Operating Temperature Range	Style	See page(s) for detail
HIGH TEMPERATURE						
Hi Temp (HT/HP)	100 to 200 VDC	C0G: 16 pF-.100 µF X7R:1000 pF-1.0µF	C0G 0.15% X7R Type 2.0% X7R 2.50%	-55°C to + 200°C	Axial/Radial	5
Hi Temp Hi Volt (HV)	500 to 4000 VDC	C0G: 390 pF-.015 µF X7R:1400 pF- .270 µF	C0G 0.15% X7R Type 2.0% X7R 2.50%	-55°C to + 200°C	Radial	6
Ceramic Cased Capacitor						
Std 125°C (SCR/SRR/SCA/SRA)	50 to 200 VDC	C0G: 1.0 pF- .12 µF X7R:100 pF- 6.8 µF	C0G 0.15% X7R 2.50%	-55°C to + 125°C	Axial/Radial	7-10
200°C (ACR/ARR/ACA/ARA)	50 to 100 VDC	C0G: 1.0 pF- .12 µF X7R:100 pF- 3.3 µF	C0G 0.15% X7R 2.50%	-55°C to + 200°C	Axial/Radial	11-13
260°C (TCR/TRR/TCA/TRA)	50 to 100 VDC	C0G: 1.0 pF- .12 µF X7R:100 pF- 3.3 µF	C0G 0.15% X7R 2.50%	-55°C to + 260°C	Axial/Radial	14-16
Hi Temp Hi Volt (VCR/VRR)	500 to 5000 VDC	C0G: 10 pF-.056 µF X7R:330 pF-1.2µF	C0G 0.15% X7R 2.50%	-55°C to + 200°C	Radial	17-19
HIGH VOLTAGE						
Radial Conformally Coated						
Std	C0G/KDA/X7R: 500 to 10k VDC	KDA: 47 pF -1.5 µF C0G:10 pF - .330µF X7R: 150 pF - 5.6 µF	KDA: 0.2% max C0G: 0.1% max X7R: 2.5% max	KDA: -55°C to + 115°C C0G: -55°C to + 125°C X7R: -55°C to + 125°C	Radial	20-21
Mil-PRF-49467	C0G/X7R: 600 to 5k VDC	C0G: 12 pF - .68 µF X7R: 27 pF - .47 µF	C0G: 0.1% max X7R: 2.5% max	C0G/X7R: -55°C to + 125°C	Radial	22-23
Space Quality	C0G/X7R: 500 to 10k VDC	C0G: 390 pF - .180 µF X7R: 1200 pF - 2.2 µF	C0G: 0.1% max X7R: 2.5% max	C0G/X7R: -55°C to + 125°C	Radial	24-25
Ceramic Surface Mount Chip						
Military	C0G/KDA/X7R: 500 to 5k VDC	KDA: 100 pF-.680 µF C0G: 12 pF- .10 µF X7R: 270 pF -2.50 µF	KDA: 0.2% max C0G: 0.1% max X7R: 2.5% max	KDA/C0G/X7R: -55°C to + 125°C	Chip	26-27
Commercial	C0G/X7R: 500 to 3k VDC	C0G: 1.0 pF-.010 µF X7R: 10 pF-.22 µF	C0G: 0.1% max X7R: 2.5% max	C0G/X7R: -55°C to + 125°C	Chip	28-31
Leaded Chips	C0G/KDA/X7R: 500 to 10k VDC	KDA: 47 pF-1.50 µF C0G: 10 pF-.330 µF X7R: 150 pF-5.6 uF	KDA: 0.2% max C0G: 0.1% max X7R: 2.5% max	KDA/C0G/X7R: -55°C to + 125°C	Leaded Chip	32-33
Disc	C0G/X5U: 3k to 20k VDC, X7R:3k to 50k VDC	C0G: 1.2 pF-236 pF X7R: 10 p -7400 pF X5U: 80 pF-17300 pF	C0G: 0.1% max X7R: 2.5% max X5U: 2.5% max	C0G/X7R: -55°C to + 125°C X5U: -55°C to + +85°C	Disc	34-35
Disc Stack	C0G/X7R/X5U: 5k to 20k VDC	C0G: 1.2 pF-141 pF X7R: 37 pF-4400 pF X5U: 80 pF-10400 pF	C0G: 0.1% max X7R: 2.5% max X5U: 2.5% max	C0G/X7R: -55°C to + 125°C X5U: -55°C to + +85°C	Disc Stack	36

High Temperature (+200°C) Axial and Radial Ceramic Capacitors HT/HP Series



FEATURES

The HT/HP Series is used in robust applications

- Down Hole
- Industrial
- Harsh Environments

Where a Radial/Axial coated capacitor can withstand high temperatures (200°C).

NOTE:

Other tolerances, higher capacitance values, voltages, or special package configurations are available upon request.

CAPACITOR OUTLINE DRAWING

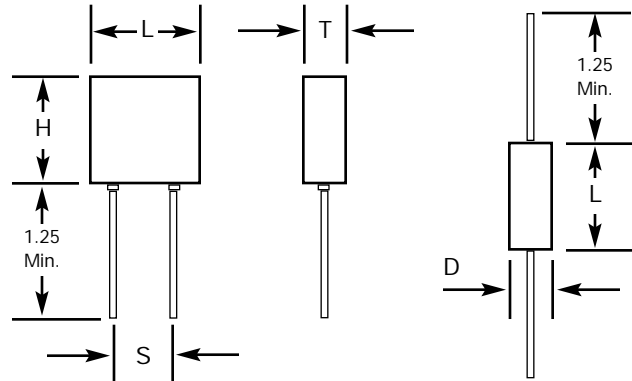

DIMENSIONS

Molded (HT) and Conformal Coated (HP), Radial Lead Types

Style	Sizes in Inches (mm) max			Lead Spacing ±0.030 (S)
	Length (L)	Height (H)	Thickness (T)	
HT05	.200 (5.08)	.200 (5.08)	.100 (2.54)	.100 (2.54)
HT55	.200 (5.08)	.200 (5.08)	.100 (2.54)	.200 (5.08)
HT06	.300 (7.62)	.300 (7.62)	.150 (3.81)	.200 (5.08)
HT08	.500 (12.70)	.500 (12.70)	.250 (6.35)	.400 (10.16)
HT09	.700 (17.78)	.400 (10.16)	.200 (5.08)	.500 (12.70)

Tubular Case, Axial Lead Types

Style	Sizes in Inches (mm) max	
	Length (L)	Diameter (D)
HT11	.170 (4.32)	.100 (2.54)
HT13	.260 (6.60)	.135 (3.43)
HT14	.400 (10.16)	.155 (3.94)
HT15	.500 (12.70)	.200 (5.08)
HT16	.750 (19.05)	.375 (9.52)

CAPACITANCE AVAILABLE

**Dielectric Capacitance Ranges
COG (NP0) at +125°C**

Style	100 VDC		200 VDC	
	Min.	Max.	Min.	Max.
HT05	22pF	.010µF	22pF	8200pF
HT55	22pF	.010µF	22pF	8200pF
HT06	1000pF	.033µF	1000pF	.027µF
HT08	.010µF	.100µF	.010µF	.082µF
HT09	.010µF	.100µF	.010µF	.082µF
HT11	16pF	1000pF	16pF	820pF
HT13	16pF	.010µF	16pF	8200pF
HT14	1000pF	.033µF	1000pF	.027µF
HT15	.010µF	.047µF	.010µF	.039µF
HT16	.010µF	.100µF	.010µF	.082µF

**Dielectric Capacitance Ranges
(X7R Type) at +125°C**

Style	100 VDC		200 VDC	
	Min.	Max.	Min.	Max.
HT05	1000pF	.027µF	1000pF	.018µF
HT55	1000pF	.027µF	1000pF	.018µF
HT06	.010µF	.47µF	.010µF	.150µF
HT08	.100µF	1.0µF	.100µF	.390µF
HT09	.100µF	1.0µF	.100µF	.680µF
HT11	1000pF	.022µF	1000pF	.018µF
HT13	1000pF	.10µF	1000pF	.027µF
HT14	.010µF	.18µF	.015µF	.056µF
HT15	.010µF	.56µF	.027µF	.390µF
HT16	.100µF	1.0µF	.100µF	.680µF

For CONFORMAL COATED types, change style number to HPXX. HP dimensions will be reduced slightly.

PART NUMBER AND ORDERING INFORMATION

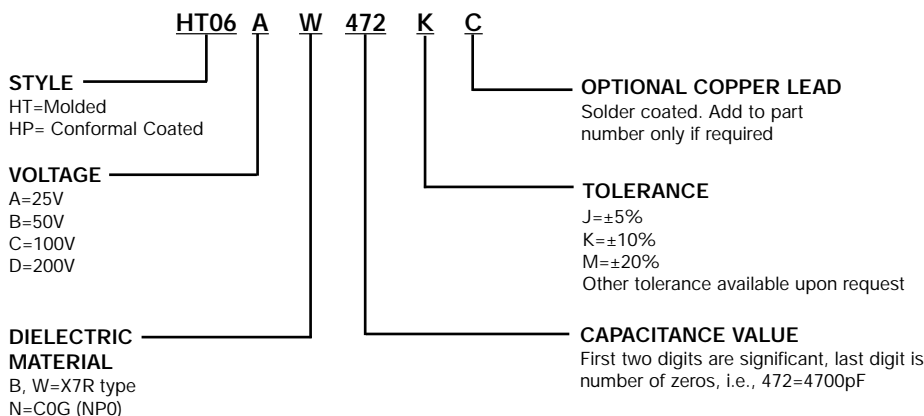

MARKING

(HT05, HT55, HT11)
472K
KEC

(All other sizes)
HT06AW472K
KEC
Date Code

FEATURES

The HV series not only withstands high temperatures (200°C), but also offers high voltage (500-4000 VDC)

To be used in robust applications

- Down Hole
- Industrial
- Harsh Environments

NOTE:

Other tolerances, higher capacitance values, voltages, or special package configurations are available upon request.

CAPACITOR OUTLINE DRAWING

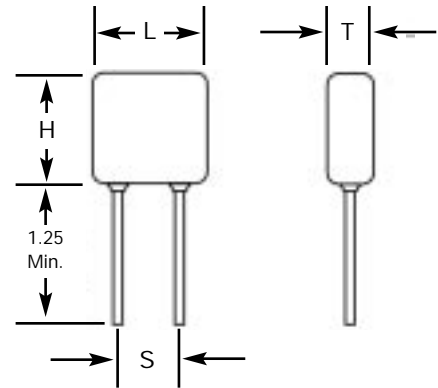

DIMENSIONS

Style	Sizes in Inches (mm) max.			Lead Spacing ±0.030 (S)
	Length (L)	Height (H)	Thickness (T)	
HV10	.250 (6.35)	.220 (5.59)	.150 (3.81)	.170 (4.32)
HV11	.320 (8.13)	.300 (7.62)	.250 (6.35)	.200 (5.08)
HV12	.420 (10.67)	.400 (10.16)	.250 (6.35)	.300 (7.62)
HV13	.520 (13.21)	.500 (12.70)	.300 (7.62)	.400 (10.16)
HV14	.620 (15.75)	.500 (12.70)	.300 (7.62)	.500 (12.70)
HV15	.720 (18.29)	.700 (17.78)	.300 (7.62)	.600 (15.24)
HV16	.820 (20.83)	.700 (17.78)	.350 (8.89)	.700 (17.78)

MAXIMUM CAPACITANCE AVAILABLE

Style	500 VDC		1k VDC		2k VDC		3k VDC		4k VDC	
	NPO	X7R	NPO	X7R	NPO	X7R	NPO	X7R	NPO	X7R
HV10	1500pF	8200pF	1000pF	2700pF	390pF	1400pF	---	---	---	---
HV11	2200pF	.022μF	1800pF	.010μF	1000pF	2700pF	470pF	---	---	---
HV12	3300pF	.033μF	2700pF	.018μF	1500pF	6800pF	1000pF	---	---	---
HV13	5600pF	.082μF	4700pF	.047μF	3300pF	.018μF	2700pF	8200pF	---	---
HV14	8200pF	.120μF	7500pF	.056μF	3900pF	.027μF	3300pF	.012μF	2700pF	.010μF
HV15	.010μF	.150μF	.010μF	.068μF	4700pF	.033μF	3900pF	.018μF	2700pF	.010μF
HV16	.015μF	.270μF	.015μF	.120μF	.012μF	.056μF	8200pF	.027μF	5600pF	.012μF

HVXX Continued on pages 20-23

PART NUMBER AND ORDERING INFORMATION

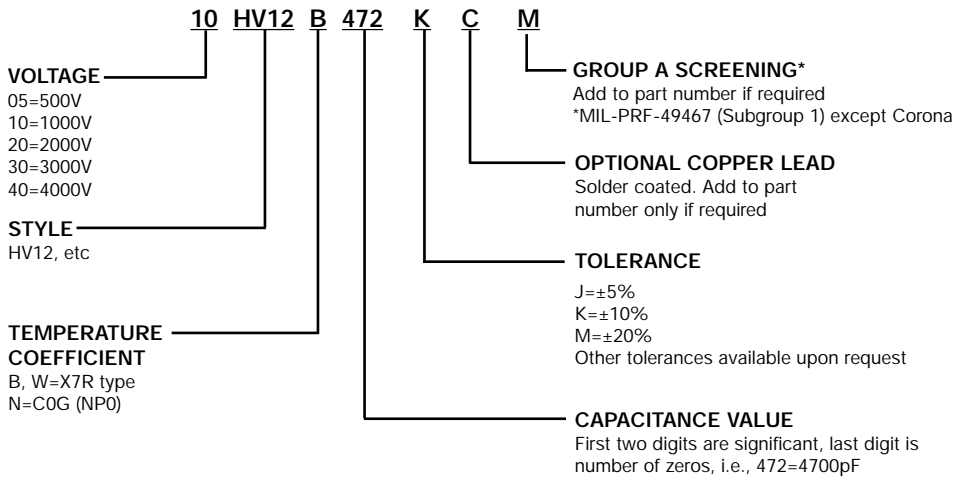

MARKING
(HV10, HV11)
472M
KEC
Date Code

(All other sizes)
HV12B472M
1kV
KEC
Date Code

C³ GENERAL INFORMATION

Monolithic ceramic capacitors are capable of withstanding and operating at temperatures up to +260°C when properly designed and manufactured for this application. A design has been developed which is ideal for operation at these high temperatures. This design is a Ceramic Cased Capacitor (C³) as described in PATENT #4,931,899.

The advantages of the C³ construction at 125°C, 200°C and 260°C are:

- Uniform coefficient of linear expansion eliminates chip cracking during thermal shock.
- No "pull-away" of epoxy potting from epoxy case at elevated temperatures.
- Resistant to moisture penetration.
- Superior volumetric efficiency

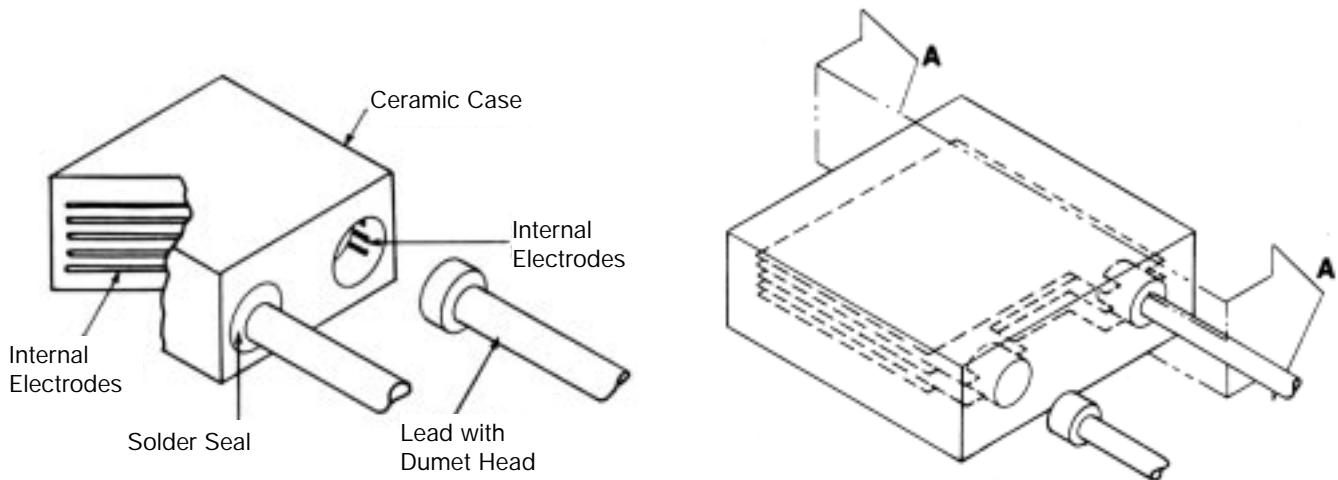

Radial C³ - One Lead Removed

Radial C³ - Capacitor Internal Construction

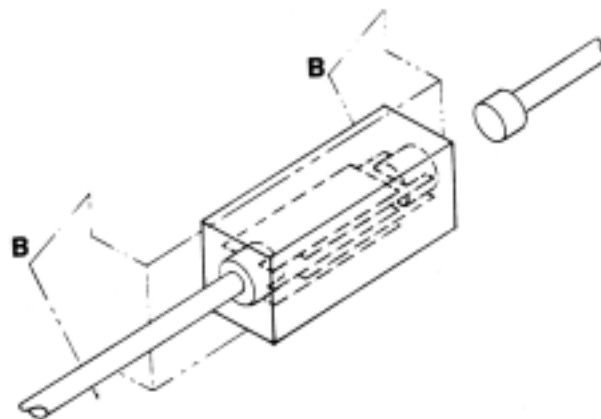

Axial C³ - One Lead Removed

High Temperature Standard (+125°C) Axial and Radial Ceramic Cased Capacitors (C³) SCR/SRR/SCA/SRA Series

COG

COG (NPO) capacitors which exhibit little change in capacitance with variations in temperature, are used in RF oscillators, precision timing circuits, wave filters and other circuits requiring a predictable linear temperature coefficient.

Installation:

Parts should be soldered using a heat sink between the soldering point and the part using a soldering iron rated between 18-30 watts. Soldering temperature should not exceed +300°C. For wave soldering, the parts should be slowly heated to +150°C and, after soldering, be allowed to cool down slowly to +90°C to preclude thermal shocking of the parts.

X7R

BX and X7R capacitors are used in coupling circuits (IF and RF); for bypassing and decoupling in computers and stereo systems; power supply line filtering and frequency discrimination.

Installation:

Parts should be soldered using a heat sink between the soldering point and the part using a soldering iron rated between 18-30 watts. Soldering temperature should not exceed +300°C. For wave soldering, the parts should be slowly heated to +150°C and, after soldering, be allowed to cool down slowly to +90°C to preclude thermal shocking of the parts.

PART NUMBER AND ORDERING INFORMATION

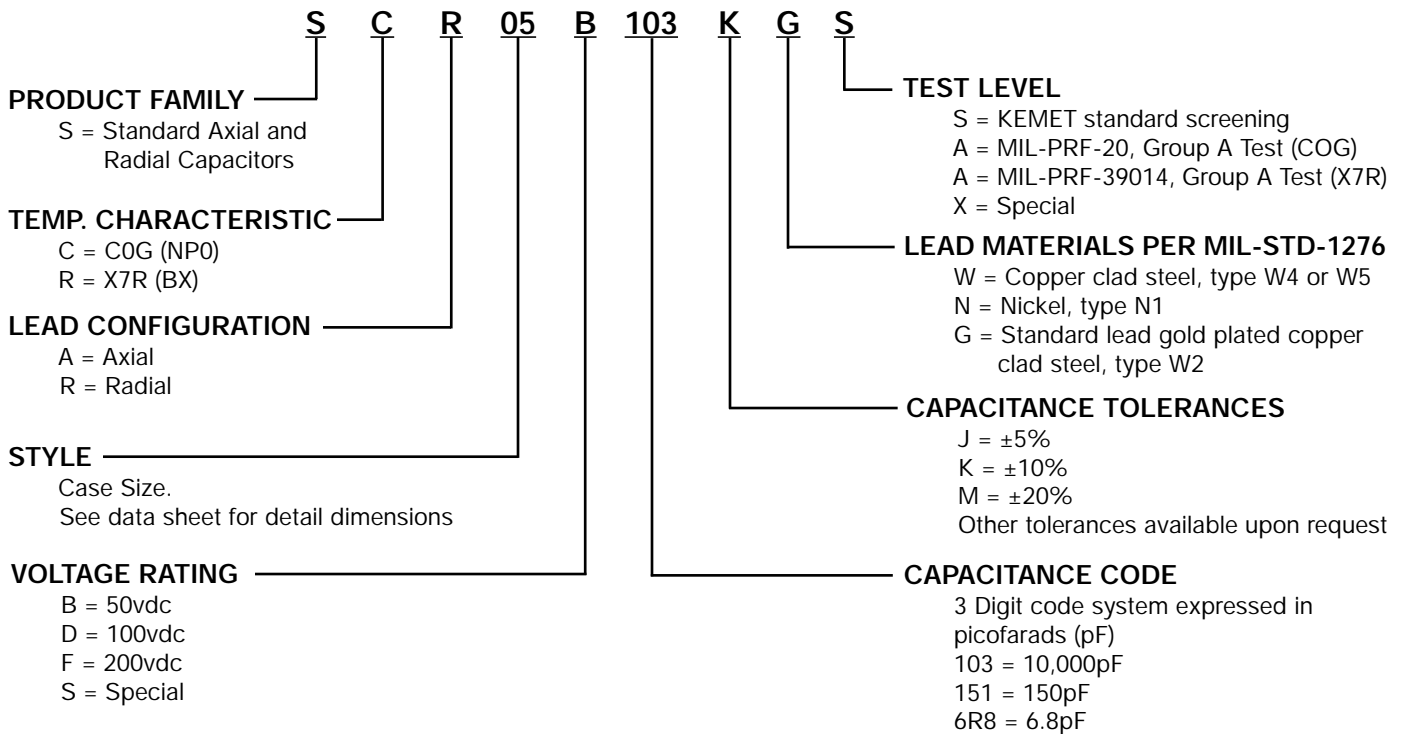

MARKING

Manufacturer's ID	KEC
Capacitance	106J
Voltage	50V
Date Code	123

High Temperature Standard (+200°C) Axial and Radial Ceramic Cased Capacitors (C³) ACR/ARR/ACA/ARA Series



High temperature ceramic cased capacitors, with a new, unique design concept, are ideally suited for continuous operation up to +200°C. Problems associated with epoxy cased/epoxy potted capacitors, such as material deterioration, cracks in cases and potted areas, are nonexistent, even at +200°C.

C0G

C0G (NPO) capacitors, which exhibit little change in capacitance with variations in temperature, are used in RF oscillators, precision timing circuits, wave filters, and other circuits requiring a predictable linear temperature coefficient.

Installation:

Parts should be soldered using a heat sink between the soldering point and the part using a soldering iron rated between 18-30 watts. Soldering temperature should not exceed +300°C.

X7R

Specially formulated X7R ceramic materials result in a retention of 40% of the +25°C capacitance. Dissipation factor drops from 1.25% at +25°C to 0.1% at +200°C. At +120°C the ceramic undergoes a transformation (crystalline inversion) resulting in the material changing from ferroelectric to paraelectric - no piezoelectric behavior.

Typical applications include oil well logging (down hole), jet engine controls and geophysical pressure probes.

Installation:

Parts should be soldered using a heat sink between the soldering point and the part using a soldering iron rated between 18-30 watts. Soldering temperature should not exceed +300°C.

PART NUMBER AND ORDERING INFORMATION

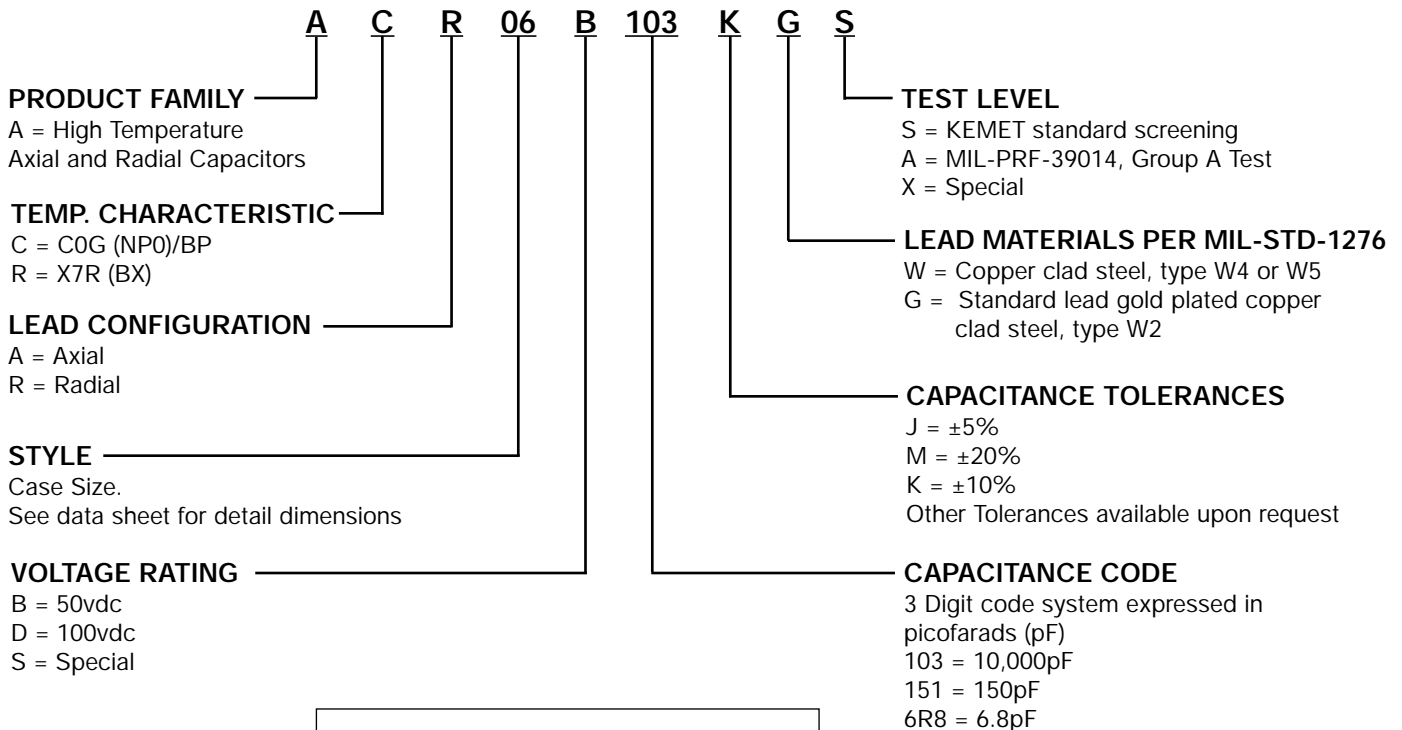

MARKING	
Manufacturer's ID	KEC
Capacitance	106J
Voltage	50V
Date Code	123

High Temperature Standard (+200°C) Axial and Radial Ceramic Cased Capacitors (C³)

ACR/ACA Series

AXIAL

All Dimensions
in Inches (mm)

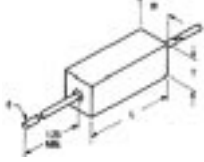

RADIAL

All Dimensions
in Inches (mm)



STYLE		16		25		39		50		69		05		06		07		08		09	
DIMENSIONS	L max	.170 (4.32)		.270 (6.86)		.400 (10.16)		.520 (13.21)		.720 (18.29)		.200 (5.08)		.300 (7.62)		.300 (7.62)		.500 (11.70)		.500 (11.70)	
	W max	.080 (2.02)		.100 (2.54)		.150 (3.81)		.265 (6.73)		.370 (9.40)		.200 (5.08)		.300 (7.62)		.300 (7.62)		.500 (11.70)		.500 (11.70)	
	T max	.080 (2.02)		.100 (2.54)		.150 (3.81)		.160 (4.06)		.160 (4.06)		.100 (2.54)		.100 (2.54)		.150 (3.81)		.100 (2.54)		.100 (2.54)	
	D											.200 ±.015 (5.08 ±.38)		.200 ±.015 (5.08 ±.38)		.200 ±.015 (5.08 ±.38)		.400 ±.015 (10.16 ±.38)		.400 ±.015 (10.16 ±.38)	
	d	.020 ±.002 (.508 ±.051)		.020 ±.002 (.508 ±.051)		.025 ±.002 (.635 ±.051)		.025 ±.002 (.635 ±.051)		.025 ±.002 (.635 ±.051)		.020 ±.002 (.508 ±.051)		.020 ±.002 (.508 ±.051)		.020 ±.002 (.508 ±.051)		.025 ±.002 (.635 ±.051)		.025 ±.002 (.635 ±.051)	
WVDC		50 100		50 100		50 100		50 100		50 100		50 100		50 100		50 100		50 100		50 100	
CAPACITANCE RANGE	1.0 (pF)	■		■		■		■		■		■		■		■		■		■	
	1.2	■		■		■		■		■		■		■		■		■		■	
	1.5	■		■		■		■		■		■		■		■		■		■	
	1.8	■		■		■		■		■		■		■		■		■		■	
	2.2	■		■		■		■		■		■		■		■		■		■	
	2.9	■		■		■		■		■		■		■		■		■		■	
	3.3	■		■		■		■		■		■		■		■		■		■	
	3.9	■		■		■		■		■		■		■		■		■		■	
	4.7	■		■		■		■		■		■		■		■		■		■	
	5.6	■		■		■		■		■		■		■		■		■		■	
	6.8	■		■		■		■		■		■		■		■		■		■	
	8.2	■		■		■		■		■		■		■		■		■		■	
	10	■		■		■		■		■		■		■		■		■		■	
	12	■		■		■		■		■		■		■		■		■		■	
	15	■		■		■		■		■		■		■		■		■		■	
	18	■		■		■		■		■		■		■		■		■		■	
	22	■		■		■		■		■		■		■		■		■		■	
	27	■		■		■		■		■		■		■		■		■		■	
	33	■		■		■		■		■		■		■		■		■		■	
	39	■		■		■		■		■		■		■		■		■		■	
	47	■		■		■		■		■		■		■		■		■		■	
	56	■		■		■		■		■		■		■		■		■		■	
	68	■		■		■		■		■		■		■		■		■		■	
	82	■		■		■		■		■		■		■		■		■		■	
	100	■		■		■		■		■		■		■		■		■		■	
	120	■		■		■		■		■		■		■		■		■		■	
	150	■		■		■		■		■		■		■		■		■		■	
	180	■		■		■		■		■		■		■		■		■		■	
	220	■		■		■		■		■		■		■		■		■		■	
	270	■		■		■		■		■		■		■		■		■		■	
	330	■		■		■		■		■		■		■		■		■		■	
	390	■		■		■		■		■		■		■		■		■		■	
	470	■		■		■		■		■		■		■		■		■		■	
	560	■		■		■		■		■		■		■		■		■		■	
	680	■		■		■		■		■		■		■		■		■		■	
	820	■		■		■		■		■		■		■		■		■		■	
	1000	■		■		■		■		■		■		■		■		■		■	
	1200	■		■		■		■		■		■		■		■		■		■	
	1500	■		■		■		■		■		■		■		■		■		■	
	1800	■		■		■		■		■		■		■		■		■		■	
	2200	■		■		■		■		■		■		■		■		■		■	
	2700	■		■		■		■		■		■		■		■		■		■	
3300	■		■		■		■		■		■		■		■		■		■		
3900	■		■		■		■		■		■		■		■		■		■		
4700	■		■		■		■		■		■		■		■		■		■		
5600	■		■		■		■		■		■		■		■		■		■		
6800	■		■		■		■		■		■		■		■		■		■		
8200	■		■		■		■		■		■		■		■		■		■		
.01 (μF)	■		■		■		■		■		■		■		■		■		■		
.012	■		■		■		■		■		■		■		■		■		■		
.015	■		■		■		■		■		■		■		■		■		■		
.018	■		■		■		■		■		■		■		■		■		■		
.022	■		■		■		■		■		■		■		■		■		■		
.027	■		■		■		■		■		■		■		■		■		■		
.033	■		■		■		■		■		■		■		■		■		■		
.039	■		■		■		■		■		■		■		■		■		■		
.047	■		■		■		■		■		■		■		■		■		■		
.056	■		■		■		■		■		■		■		■		■		■		
.068	■		■		■		■		■		■		■		■		■		■		
.082	■		■		■		■		■		■		■		■		■		■		
.10	■		■		■		■		■		■		■		■		■		■		
.12	■		■		■		■		■		■		■		■		■		■		

NOTES:

- C0G (NP0) dielectric
- Capacitor sizes and capacitance values shown in the table are standard. Other sizes and capacitance values are available upon request.

High Temperature (+260°C) Axial and Radial Ceramic Cased Capacitors (C³) TCR/TRR/TCA/TRR Series

High temperature ceramic cased capacitors, with a new, unique design concept, are ideally suited for continuous operation up to +260°C. Problems associated with epoxy cased/epoxy potted capacitors, such as material deterioration, cracks in cases and potted areas, are nonexistent, even at +260°C.

C0G

C0G (NPO) capacitors, which exhibit little change in capacitance with variations in temperature, are used in RF oscillators, precision timing circuits, wave filters, and other circuits requiring a predictable linear temperature coefficient.

Installation:

Parts should be soldered using a heat sink between the soldering point and the part using a soldering iron rated between 18-30 watts. Soldering temperature should not exceed +300°C.

X7R

Conventional X7R materials lose up to 75% of the +25°C capacitance. Dissipation factor drops from 1.25% at +25°C to 0.2% at +260°C. At +120°C the ceramic undergoes a transformation (crystalline inversion) resulting in the material changing from ferroelectric to paraelectric - no piezoelectric behavior. Typical applications include oil well logging (down hole), jet engine controls and geophysical pressure probes.

Installation:

Parts should be soldered using a heat sink between the soldering point and the part using a soldering iron rated 18-30 watts. Soldering temperature should not exceed +300°C.

PART NUMBER AND ORDERING INFORMATION

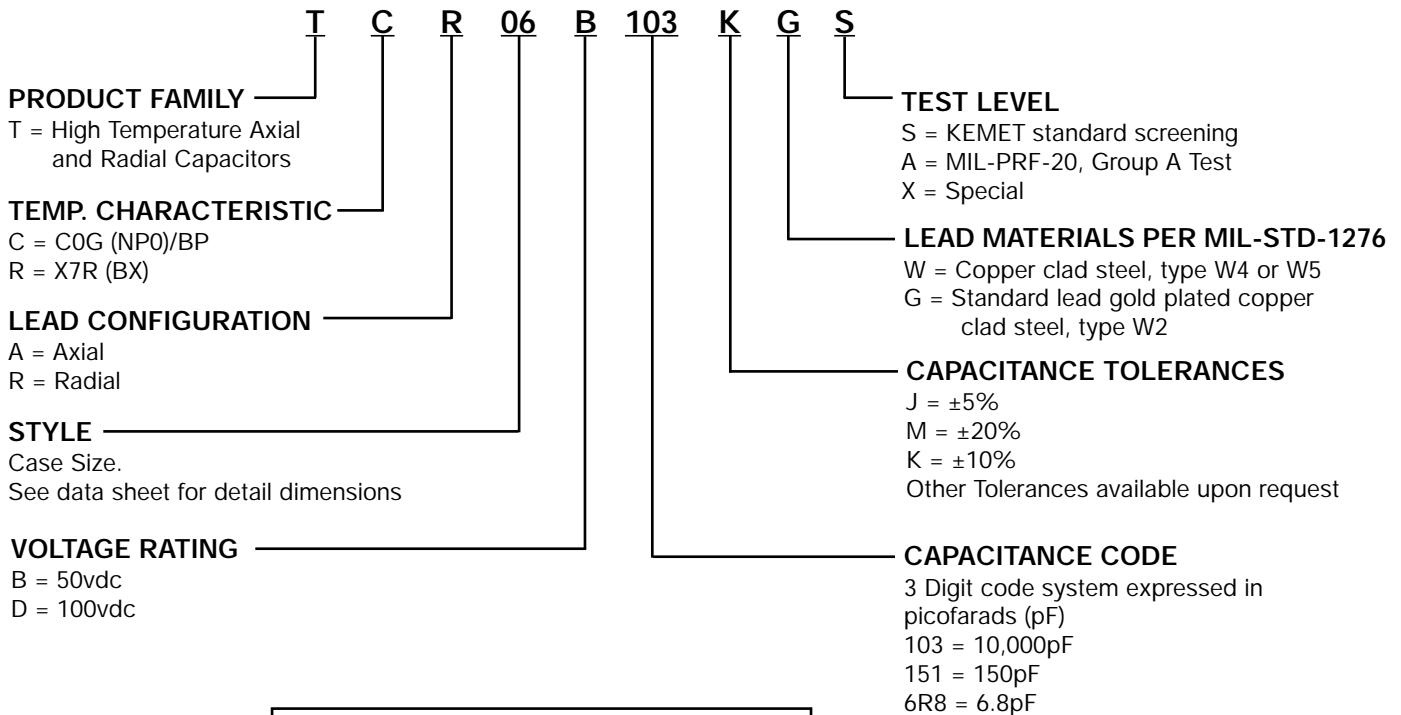

Marking	Example
Manufacturer's ID	KEC
Capacitance	106J
Voltage	50V
Date Code	123
Red dot = +260°C	•

High Temperature (+260°C) Axial and Radial Ceramic Cased Capacitors (C³) TCR/TCA Series



AXIAL

All Dimensions
in Inches (mm)

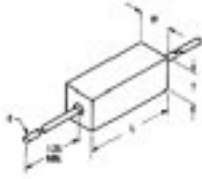

RADIAL

All Dimensions
in Inches (mm)



STYLE		16		25		39		50		69		05		06		07		08		09	
DIMENSIONS	L max	.170 (4.32)		.270 (6.86)		.400 (10.16)		.520 (13.21)		.720 (18.29)		.200 (5.08)		.300 (7.62)		.300 (7.62)		.500 (11.70)		.500 (11.70)	
	W max	.080 (2.02)		.100 (2.54)		.150 (3.81)		.265 (6.73)		.370 (9.40)		.200 (5.08)		.300 (7.62)		.300 (7.62)		.500 (11.70)		.500 (11.70)	
	T max	.080 (2.02)		.100 (2.54)		.150 (3.81)		.160 (4.06)		.160 (4.06)		.100 (2.54)		.100 (2.54)		.150 (3.81)		.100 (2.54)		.100 (2.54)	
	D											.200 ±.015 (5.08 ±.38)		.200 ±.015 (5.08 ±.38)		.200 ±.015 (5.08 ±.38)		.400 ±.015 (10.16 ±.38)		.400 ±.015 (10.16 ±.38)	
	d	.020 ±.002 (.508 ±.051)		.020 ±.002 (.508 ±.051)		.025 ±.002 (.635 ±.051)		.025 ±.002 (.635 ±.051)		.025 ±.002 (.635 ±.051)		.020 ±.002 (.508 ±.051)		.020 ±.002 (.508 ±.051)		.020 ±.002 (.508 ±.051)		.025 ±.002 (.635 ±.051)		.025 ±.002 (.635 ±.051)	
WVDC		50	100	50	100	50	100	50	100	50	100	50	100	50	100	50	100	50	100	50	100
CAPACITANCE RANGE	1.0 (pF)	■		■		■		■		■		■		■		■		■		■	
	1.2	■		■		■		■		■		■		■		■		■		■	
	1.5	■		■		■		■		■		■		■		■		■		■	
	1.8	■		■		■		■		■		■		■		■		■		■	
	2.2	■		■		■		■		■		■		■		■		■		■	
	2.9	■		■		■		■		■		■		■		■		■		■	
	3.3	■		■		■		■		■		■		■		■		■		■	
	3.9	■		■		■		■		■		■		■		■		■		■	
	4.7	■		■		■		■		■		■		■		■		■		■	
	5.6	■		■		■		■		■		■		■		■		■		■	
	6.8	■		■		■		■		■		■		■		■		■		■	
	8.2	■		■		■		■		■		■		■		■		■		■	
	10	■		■		■		■		■		■		■		■		■		■	
	12	■		■		■		■		■		■		■		■		■		■	
	15	■		■		■		■		■		■		■		■		■		■	
	18	■		■		■		■		■		■		■		■		■		■	
	22	■		■		■		■		■		■		■		■		■		■	
	27	■		■		■		■		■		■		■		■		■		■	
	33	■		■		■		■		■		■		■		■		■		■	
	39	■		■		■		■		■		■		■		■		■		■	
	47	■		■		■		■		■		■		■		■		■		■	
	56	■		■		■		■		■		■		■		■		■		■	
	68	■		■		■		■		■		■		■		■		■		■	
	82	■		■		■		■		■		■		■		■		■		■	
	100	■		■		■		■		■		■		■		■		■		■	
	120	■		■		■		■		■		■		■		■		■		■	
	150	■		■		■		■		■		■		■		■		■		■	
	180	■		■		■		■		■		■		■		■		■		■	
	220	■		■		■		■		■		■		■		■		■		■	
	270	■		■		■		■		■		■		■		■		■		■	
	330	■		■		■		■		■		■		■		■		■		■	
	390	■		■		■		■		■		■		■		■		■		■	
	470	■		■		■		■		■		■		■		■		■		■	
	560	■		■		■		■		■		■		■		■		■		■	
	680	■		■		■		■		■		■		■		■		■		■	
	820	■		■		■		■		■		■		■		■		■		■	
1000	■		■		■		■		■		■		■		■		■		■		
1200	■		■		■		■		■		■		■		■		■		■		
1500	■		■		■		■		■		■		■		■		■		■		
1800	■		■		■		■		■		■		■		■		■		■		
2200	■		■		■		■		■		■		■		■		■		■		
2700	■		■		■		■		■		■		■		■		■		■		
3300	■		■		■		■		■		■		■		■		■		■		
3900	■		■		■		■		■		■		■		■		■		■		
4700	■		■		■		■		■		■		■		■		■		■		
5600	■		■		■		■		■		■		■		■		■		■		
6800	■		■		■		■		■		■		■		■		■		■		
8200	■		■		■		■		■		■		■		■		■		■		
.01 (μF)	■		■		■		■		■		■		■		■		■		■		
.012	■		■		■		■		■		■		■		■		■		■		
.015	■		■		■		■		■		■		■		■		■		■		
.018	■		■		■		■		■		■		■		■		■		■		
.022	■		■		■		■		■		■		■		■		■		■		
.027	■		■		■		■		■		■		■		■		■		■		
.033	■		■		■		■		■		■		■		■		■		■		
.039	■		■		■		■		■		■		■		■		■		■		
.047	■		■		■		■		■		■		■		■		■		■		
.056	■		■		■		■		■		■		■		■		■		■		
.068	■		■		■		■		■		■		■		■		■		■		
.082	■		■		■		■		■		■		■		■		■		■		
.10	■		■		■		■		■		■		■		■		■		■		
.12	■		■		■		■		■		■		■		■		■		■		

NOTES:

1. ■ COG (NP0) dielectric

AXIAL

All Dimensions
in Inches (mm)

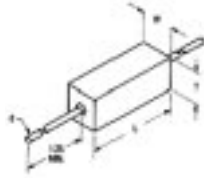

RADIAL

All Dimensions
in Inches (mm)



STYLE	16		25		39		50		69		05		06		07		08		09					
	L max	W max	T max	D	d	WVDC	Capacitance Range																	
DIMENSIONS	.170 (4.32)	.080 (2.02)	.080 (2.02)	.270 (6.86)	.100 (2.54)	.100 (2.54)	.400 (10.16)	.150 (3.81)	.150 (3.81)	.520 (13.21)	.265 (6.73)	.720 (18.29)	.370 (9.40)	.200 (5.08)	.100 (2.54)	.100 (2.54)	.200 ±0.15 (5.08 ±.38)	.200 ±0.15 (5.08 ±.38)	.200 ±0.15 (5.08 ±.38)	.400 ±0.15 (10.16 ±.38)	.400 ±0.15 (10.16 ±.38)			
DIMENSIONS	.020 ±0.002 (.508 ±.051)	.020 ±0.002 (.508 ±.051)	.020 ±0.002 (.508 ±.051)	.025 ±0.002 (.635 ±.051)	.025 ±0.002 (.635 ±.051)	.025 ±0.002 (.635 ±.051)	.025 ±0.002 (.635 ±.051)	.025 ±0.002 (.635 ±.051)	.020 ±0.002 (.508 ±.051)	.020 ±0.002 (.508 ±.051)	.020 ±0.002 (.508 ±.051)	.020 ±0.002 (.508 ±.051)	.020 ±0.002 (.508 ±.051)	.020 ±0.002 (.508 ±.051)	.020 ±0.002 (.508 ±.051)	.025 ±0.002 (.635 ±.051)	.025 ±0.002 (.635 ±.051)	.025 ±0.002 (.635 ±.051)	.025 ±0.002 (.635 ±.051)	.025 ±0.002 (.635 ±.051)				
DIMENSIONS	50	100	50	100	50	100	50	100	50	100	50	100	50	100	50	100	50	100	50	100	50	100		
CAPACITANCE RANGE	100(pF)	120	150	180	220	270	330	390	470	560	680	820	1000	1200	1500	1800	2200	2700	3300	3900	4700	5600	6800	8200
CAPACITANCE RANGE	.01 (μF)	.012	.015	.018	.022	.027	.033	.039	.047	.056	.068	.082	.10	.12	.15	.18	.22	.27	.33	.39	.47	.56	.68	.82
CAPACITANCE RANGE	1.0	1.2	1.5	1.8	2.2	2.7	3.3	3.9	4.7	5.6	6.8	8.2												

NOTES:

- X7R dielectric

High Temperature (+200°C), High Voltage Radial Ceramic Cased Capacitors (C³)



VCR/VRR Series

Ceramic cased capacitors, with a new, unique design concept which eliminates potential problems associated with conventional epoxy cased epoxy potted capacitors.

Major application is high voltage power supplies. High voltage capacitors are also utilized on high voltage meter multiplier and RF circuits.

C0G

Installation:

Parts should be soldered using a heat sink between the soldering point and the part using a soldering iron rated 18-30 watts. Remove all traces of flux or other contamination resulting from the soldering operation. An intermittent conducting path between the leads, at high voltage, could cause breakdown. Soldering temperature should not exceed +300°C.

X7R

Installation:

Parts should be soldered using a heat sink between the soldering point and the part using a soldering iron rated 18-30 watts. Remove all traces of flux or other contamination resulting from the soldering operation. An intermittent conducting path between the leads, at high voltage, could cause breakdown. Soldering temperature should not exceed +300°C.

PART NUMBER AND ORDERING INFORMATION

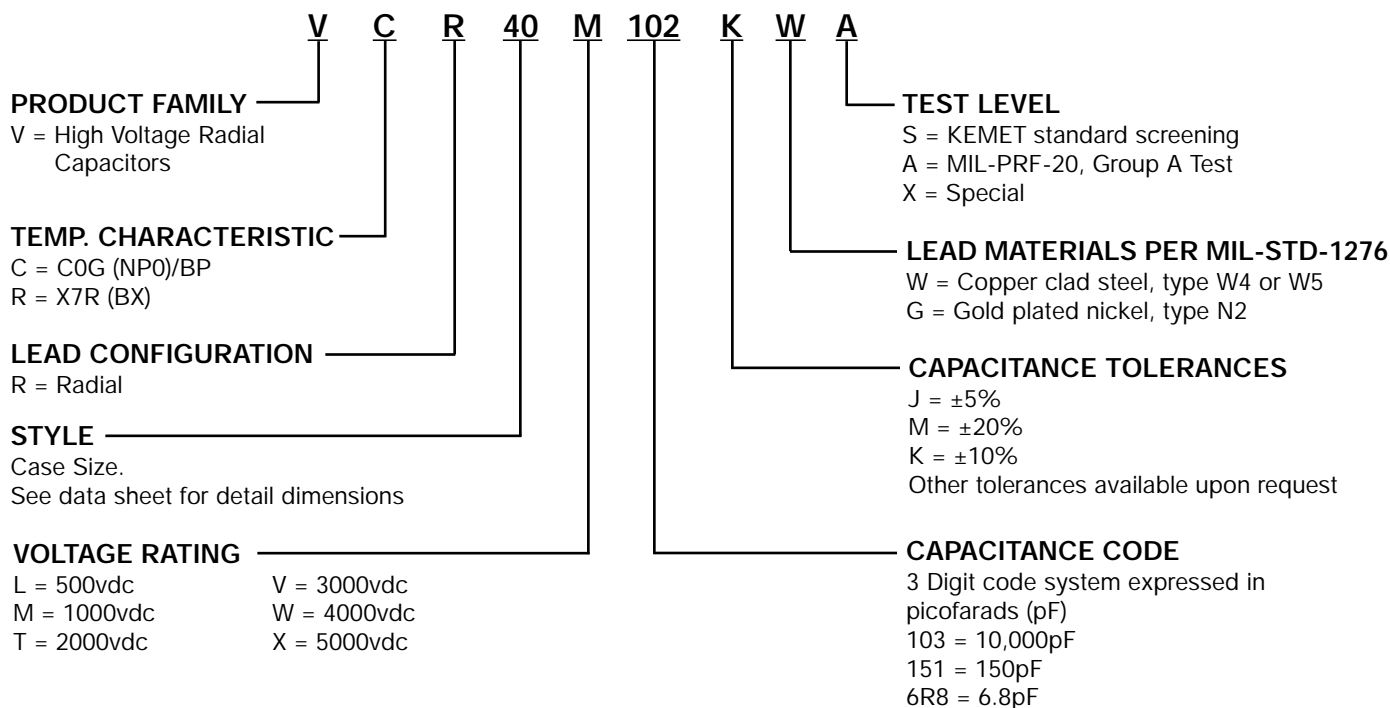

Marking	Example
Manufacturer's ID	KEC
Capacitance	106J
Voltage	500V
Date Code	123

High Voltage Radial Conformally Coated Ceramic Capacitors HV Series

Low DF, High Voltage MLC KDA -55°C to +115°C	High Voltage MLC Capacitor COG (NP0) -55°C to +125°C	High Voltage MLC Capacitor X7R -55°C to +125°C
<ol style="list-style-type: none"> 1. Non piezoelectric and very low hysteresis. 2. Low ESR over a wide frequency range. 3. Excellent performance for 400 Hz AC application. 4. VTC meets BR (-40%) at 75% rated voltage. 	<ol style="list-style-type: none"> 1. MIL-PRF-49467 established reliability type 2. Zero temperature and voltage coefficient and capacitance aging. 3. Predictable temperature coefficient. 4. Excellent frequency 	<ol style="list-style-type: none"> 1. Monolithic multilayer ceramic (MLC). 2. MIL-PRF-49467 established reliability type 3. Designed for the typical high voltage circuit application. 4. High density, low DF ceramic.
<ul style="list-style-type: none"> Group A and B screening per MIL-PRF-49467 available. Note temperature range. CSAM and Partial Discharge (Corona) available. SLAM available by special order 		

CAPACITOR OUTLINE DRAWING

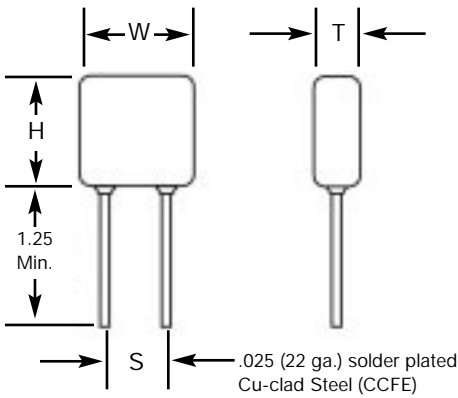

DIMENSIONS

Style	Sizes in Inches (mm) max.			Lead Spacing ±0.030 (S)
	Width (W)	Height (H)	Thickness (T)	
HV20	.250 (6.35)	.220 (5.59)	.200 (5.08)	.170 (4.32)
HV21	.320 (8.13)	.280 (7.11)	.250 (6.35)	.220 (5.59)
HV22	.370 (9.40)	.300 (7.62)	.250 (6.35)	.275 (6.98)
HV23	.470 (11.94)	.400 (10.16)	.270 (6.89)	.375 (9.52)
HV24	.570 (14.48)	.500 (12.70)	.270 (6.89)	.475 (12.06)
HV25	.670 (17.02)	.600 (15.24)	.270 (6.89)	.575 (14.60)
HV26	.770 (19.56)	.720 (18.29)	.270 (6.89)	.675 (17.14)
HV30	.450 (11.43)	.220 (5.59)	.200 (5.08)	.300 (7.62)
HV31	.550 (13.97)	.280 (7.11)	.250 (6.35)	.400 (10.16)
HV33	.850 (21.59)	.400 (10.16)	.270 (6.89)	.700 (17.78)
HV34	1.050 (26.67)	.500 (12.70)	.270 (6.89)	.975 (24.76)
HV35	1.250 (31.75)	.600 (15.24)	.270 (6.89)	1.175 (29.84)
HV36	1.450 (36.83)	.720 (18.29)	.270 (6.89)	1.375 (34.92)

PART NUMBER AND ORDERING INFORMATION

MARKING	
(HV20, HV21)	(All Other Sizes)
103K	HV24A103K
1 kV	1 kV
KEC	KEC
Date Code	Date Code

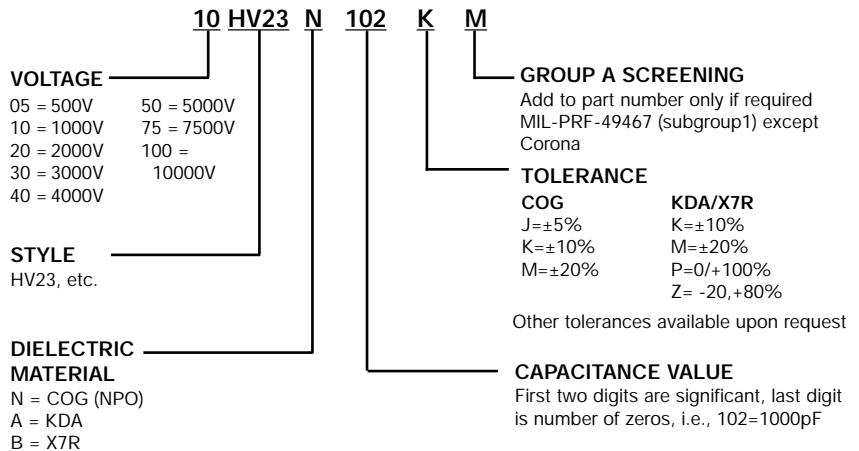

High Voltage Radial Conformally Coated Ceramic Capacitors HV Series



KDA DIELECTRIC CAPACITANCE RANGES

Style	500 VDC		1k VDC		2k VDC		3k VDC		4k VDC		5k VDC		7.5k VDC		10k VDC	
	Min.	Max.	Min.	Max.	Min.	Max.	Min.	Max.	Min.	Max.	Min.	Max.	Min.	Max.	Min.	Max.
HV20	220pF	.018μF	220pF	.012μF	100pF	2200pF	---	---	---	---	---	---	---	---	---	---
HV21	390pF	.047μF	390pF	.033μF	180pF	6800pF	180pF	3900pF	---	---	---	---	---	---	---	---
HV22	390pF	.068μF	390pF	.039μF	220pF	.010μF	220pF	4700pF	---	---	---	---	---	---	---	---
HV23	1000pF	.15μF	1000pF	.10μF	390pF	.018μF	390pF	.010μF	82pF	3900pF	---	---	---	---	---	---
HV24	1800pF	.27μF	1800pF	.18μF	820pF	.039μF	820pF	.022μF	150pF	6800pF	150pF	5600pF	---	---	---	---
HV25	3300pF	.47μF	3300pF	.27μF	1200pF	.056μF	1200pF	.033μF	220pF	.01μF	220pF	8200pF	---	---	---	---
HV26	3900pF	.68μF	3900pF	.47μF	2200pF	.10μF	2200pF	.056μF	390pF	.018μF	390pF	.015μF	---	---	---	---
HV30	560pF	.056μF	560pF	.033μF	120pF	3900pF	120pF	2700pF	47pF	1000pF	---	---	---	---	---	---
HV31	820pF	.10μF	820pF	.068μF	220pF	.01μF	220pF	5600pF	82pF	3300pF	82pF	2700pF	---	---	---	---
HV33	2700pF	.39μF	2700pF	.27μF	560pF	.039μF	560pF	.025μF	220pF	8200pF	220pF	6800pF	82pF	1800pF	---	---
HV34	3900pF	.056μF	3900pF	.39μF	1200pF	.082μF	1200pF	.047μF	390pF	.018μF	390pF	.015μF	180pF	3900pF	180pF	2200pF
HV35	5600pF	1.00μF	5600pF	.56μF	1800pF	.12μF	1800pF	.082μF	680pF	.027μF	680pF	.022μF	270pF	5600pF	270pF	3300pF
HV36	8200pF	1.50μF	8200pF	.82μF	2200pF	.18μF	2200pF	.12μF	1000pF	.047μF	1000pF	.039μF	390pF	.010μF	390pF	5600pF

COG (NP0) DIELECTRIC CAPACITANCE RANGES

Style	500 VDC		1k VDC		2k VDC		3k VDC		4k VDC		5k VDC		7.5k VDC		10k VDC	
	Min.	Max.	Min.	Max.	Min.	Max.	Min.	Max.	Min.	Max.	Min.	Max.	Min.	Max.	Min.	Max.
HV20	27pF	4700pF	27pF	1500pF	12pF	680pF	12pF	150pF	---	---	---	---	---	---	---	---
HV21	39pF	8200pF	39pF	3900pF	22pF	820pF	22pF	560pF	---	---	---	---	---	---	---	---
HV22	47pF	.01μF	47pF	6800pF	27pF	1200pF	27pF	680pF	---	---	---	---	---	---	---	---
HV23	120pF	.022μF	120pF	.018μF	47pF	3300pF	47pF	1500pF	27pF	680pF	---	---	---	---	---	---
HV24	220pF	.056μF	220pF	.033μF	100pF	6800pF	100pF	3900pF	18pF	1500pF	18pF	1000pF	---	---	---	---
HV25	390pF	.082μF	390pF	.047μF	150pF	.01μF	150pF	6800pF	27pF	2200pF	27pF	2200pF	---	---	---	---
HV26	470pF	.10μF	470pF	.068μF	270pF	.022μF	270pF	8200pF	47pF	3900pF	47pF	2700pF	---	---	---	---
HV30	68pF	.015μF	68pF	4700pF	15pF	1000pF	15pF	390pF	10pF	220pF	---	---	---	---	---	---
HV31	82pF	.027μF	82pF	.010μF	27pF	2200pF	27pF	820pF	10pF	560pF	10pF	390pF	---	---	---	---
HV33	330pF	.120μF	330pF	.068μF	68pF	.01μF	68pF	4700pF	27pF	1500pF	27pF	1200pF	12pF	470pF	---	---
HV34	470pF	.150μF	470pF	.056μF	120pF	.015μF	120pF	5600pF	47pF	3300pF	47pF	2200pF	18pF	1000pF	18pF	820pF
HV35	680pF	.220μF	680pF	.10μF	220pF	.022μF	220pF	.015μF	82pF	5600pF	82pF	3900pF	33pF	1800pF	33pF	1200pF
HV36	1000pF	.330μF	1000pF	.15μF	270pF	.039μF	270pF	.018μF	120pF	8200pF	120pF	5600pF	56pF	2700pF	56pF	5600pF

X7R DIELECTRIC CAPACITANCE RANGES

Style	500 VDC		1k VDC		2k VDC		3k VDC		4k VDC		5k VDC		7.5k VDC		10k VDC	
	Min.	Max.	Min.	Max.	Min.	Max.	Min.	Max.	Min.	Max.	Min.	Max.	Min.	Max.	Min.	Max.
HV20	680pF	.082μF	680pF	.022μF	270pF	3900pF	---	---	---	---	---	---	---	---	---	---
HV21	1200pF	.180μF	1200pF	.068μF	560pF	.012μF	560pF	3900pF	---	---	---	---	---	---	---	---
HV22	1200pF	.220μF	1200pF	.082μF	680pF	.018μF	680pF	5600pF	---	---	---	---	---	---	---	---
HV23	3300pF	.560μF	3300pF	.270μF	1200pF	.033μF	1200pF	.015μF	270pF	6800pF	---	---	---	---	---	---
HV24	6800pF	1.20μF	6800pF	.470μF	2700pF	.068μF	2700pF	.033μF	470pF	.010μF	470pF	6800pF	---	---	---	---
HV25	.010μF	1.80μF	.010μF	.680μF	3900pF	.100μF	3900pF	.390μF	680pF	.015μF	680pF	.010μF	---	---	---	---
HV26	.015μF	2.50μF	.015μF	1.00μF	6800pF	.180μF	6800pF	.082μF	1200pF	.027μF	1200pF	.015μF	---	---	---	---
HV30	1800pF	.220μF	1800pF	.056μF	390pF	8200pF	390pF	2200pF	150pF	1200pF	---	---	---	---	---	---
HV31	2700pF	.390μF	2700pF	.150μF	680pF	.022μF	680pF	8200pF	270pF	4700pF	270pF	2700pF	---	---	---	---
HV33	.010μF	1.50μF	.010μF	.680μF	1800pF	.082μF	1800pF	.270μF	680pF	.012μF	680pF	8200pF	220pF	3300pF	---	---
HV34	.012μF	2.20μF	.012μF	1.00μF	3300pF	.150μF	3300pF	.056μF	1200pF	.027μF	1200pF	.022μF	470pF	6800pF	470pF	3900pF
HV35	.018μF	3.90μF	.018μF	1.50μF	5600pF	.250μF	5600pF	.082μF	2200pF	.047μF	2200pF	.027μF	820pF	.010μF	820pF	5600pF
HV36	.027μF	5.60μF	.027μF	2.20μF	8200pF	.390μF	8200pF	.120μF	3300pF	.068μF	3300pF	.390μF	1200pF	.018μF	1200pF	.010μF

FEATURES

1. Electrical characteristics and environmental information on these parts may be obtained by referring to MIL-PRF-49467.
2. All parts are conformal coated multilayer ceramic.
3. Designed to provide excellent long-term reliability.
4. Parts are Group A screened per MIL-PRF-49467 which includes 100% Corona testing and meet all other specification requirements.
5. Designed for surface, sea and airborne military and commercial high-reliability applications.
6. No IR degradation over life.
7. BR (X7R) V/TC is -40% at rated voltage and BZ (X7R) V/TC is -40% at 60% rated voltage.
8. BX characteristic (-25%) on BR parts is approximately 52% rated voltage.
9. 100% Non-destructive test by means of CSAM inspection available. SLAM available by special order.

CAPACITOR OUTLINE DRAWING

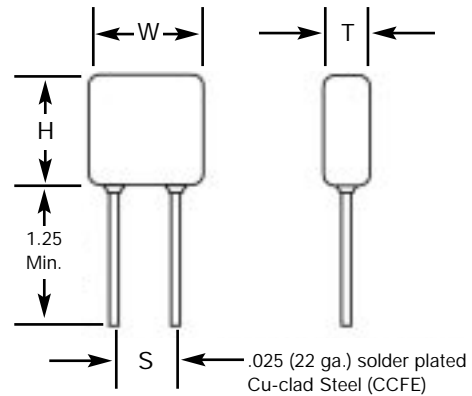

DIMENSIONS

Style	Sizes in Inches (mm) max.			Lead Spacing ±0.030 (S)
	Width (W)	Height (H)	Thickness (T)	
HV60	.250 (6.35)	.220 (5.59)	.200 (5.08)	.170 (4.32)
HV61	.320 (8.13)	.280 (7.11)	.250 (6.35)	.220 (5.59)
HV62	.370 (9.40)	.300 (7.62)	.250 (6.35)	.275 (6.98)
HV63	.470 (11.94)	.400 (10.16)	.270 (6.86)	.375 (9.52)
HV64	.570 (14.48)	.500 (12.70)	.270 (6.86)	.475 (12.06)
HV65	.670 (17.02)	.600 (15.24)	.270 (6.86)	.575 (14.60)
HV66	.770 (19.56)	.720 (18.29)	.270 (6.86)	.675 (17.14)
HV68	1.300 (33.02)	.600 (15.24)	.270 (6.86)	1.175 (29.84)
HV69	1.500 (38.10)	.720 (18.29)	.270 (6.86)	1.375 (34.92)

PART NUMBER AND ORDERING INFORMATION

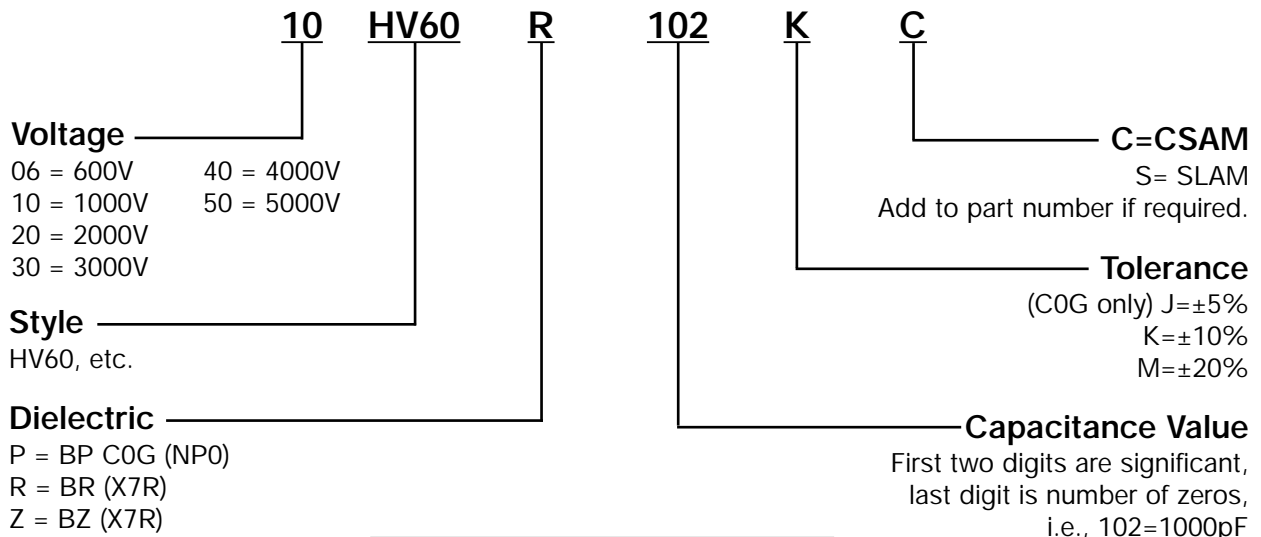

MARKING	
(HV60, HV61)	(All Other Sizes)
102K	HV63R102K
1 kV	1 kV
KEC	KEC
Date Code	Date Code

High Voltage MIL-PRF-49467 (Equivalent) HV Series



COG (NP0)/BP DIELECTRIC CAPACITANCE RANGES

Style	600 VDC		1k VDC		2k VDC		3k VDC		4k VDC		5k VDC	
	Min.	Max.	Min.	Max.	Min.	Max.	Min.	Max.	Min.	Max.	Min.	Max.
HV60	27pF	5600pF	27pF	680pF	12pF	330pF	---	---	---	---	---	---
HV61	39pF	.012μF	39pF	1800pF	22pF	820pF	22pF	470pF	---	---	---	---
HV62	47pF	.015μF	47pF	2700pF	27pF	1200pF	27pF	680pF	---	---	---	---
HV63	120pF	.039μF	120pF	4700pF	47pF	2200pF	47pF	1500pF	47pF	1000pF	---	---
HV64	220pF	0.68μF	220pF	.01μF	100pF	4700pF	100pF	3300pF	100pF	1800pF	100pF	1200pF
HV65	---	---	390pF	.015μF	150pF	6800pF	150pF	4700pF	150pF	3300pF	150pF	2200pF
HV66	---	---	470pF	.027μF	270pF	.01μF	270pF	6800pF	270pF	4700pF	270pF	3300pF

BR, BZ (X7R) DIELECTRIC CAPACITANCE RANGES

Style	600 VDC				1k VDC				2k VDC				3k VDC			
	BR		BZ		BR		BZ		BR		BZ		BR		BZ	
	Min.	Max.	Min.	Max.	Min.	Max.	Min.	Max.	Min.	Max.	Min.	Max.	Min.	Max.	Min.	Max.
HV60	680pF	.027μF	---	---	680pF	4700pF	680pF	.01μF	270pF	1500pF	270pF	2700pF	---	---	---	---
HV61	1200pF	.082μF	---	---	1200pF	.01μF	1200pF	.015μF	560pF	3900pF	560pF	6800pF	560pF	1500pF	560pF	2700pF
HV62	1200pF	.10μF	---	---	1200pF	.015μF	1200pF	.022μF	680pF	5600pF	580pF	.01μF	680pF	2200pF	680pF	3900pF
HV63	3300pF	.27μF	---	---	3300pF	.039μF	3300pF	.056μF	1200pF	.015μF	1200pF	.027μF	1200pF	6800pF	1200pF	.012μF
HV64	6800pF	.47μF	---	---	6800pF	.10μF	6800pF	.12μF	2700pF	.033μF	2700pF	.056μF	2700pF	.012μF	2700pF	.022μF
HV65	---	---	---	---	.10μF	.15μF	.10μF	.18μF	3900pF	.047μF	3900pF	.082μF	3900pF	.022μF	3900pF	.033μF
HV66	---	---	---	---	.15μF	.47μF	---	---	6800pF	.10μF	680pF	.15μF	6800pF	.039μF	6800pF	.056μF
HV68	---	---	---	---	---	---	---	---	---	---	---	---	5600pF	.056μF	5600pF	.068μF
HV69	---	---	---	---	---	---	---	---	---	---	---	---	8200pF	.10μF	---	---

BR, BZ (X7R) DIELECTRIC CAPACITANCE RANGES

Style	4k VDC				5k VDC			
	BR		BZ		BR		BZ	
	Min.	Max.	Min.	Max.	Min.	Max.	Min.	Max.
HV63	27pF	4700pF	27pF	6800pF	---	---	---	---
HV64	470pF	6800pF	470pF	.01μF	470pF	2200pF	470pF	6800pF
HV65	680pF	.01μF	680pF	.015μF	680pF	5600pF	680pF	.01μF
HV66	1200pF	.018μF	1200pF	.027μF	1200pF	8200pF	1200pF	.015μF
HV68	2200pF	.027μF	2200pF	.039μF	2200pF	.015μF	2200pF	.022μF
HV69	3300pF	.047μF	3300pF	.056μF	3300pF	.022μF	3300pF	.056μF

High Voltage Space Quality MLC (-55° to +125°C) HS Series

FEATURES

1. Similar to NASA Spec. SSQ 21113 (1, 2 & 5kV).
2. Conforms to MIL-PRF-49467. (Group A Screening, Subgroup 1)
3. 100% Corona tested.
4. No IR degradation over life.
5. High density, low DF ceramic.
6. Conservative and proven design is recommended for non-repairable applications such as spacecraft.
7. CSAM inspections are available and is recommended for space applications. SLAM available by special order.
8. Burn-in in a non-contaminating inert fluid available.

CAPACITOR OUTLINE DRAWING

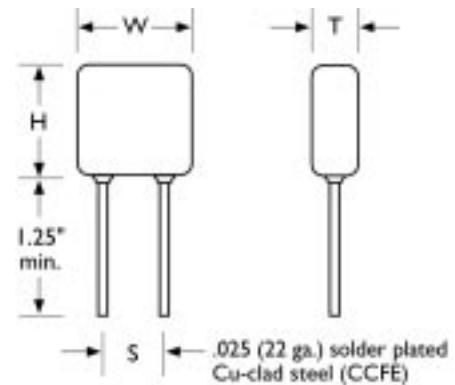

DIMENSIONS

Style	Sizes in Inches (mm) max.			Lead Spacing ±0.030 (S)
	Width (W)	Height (H)	Thickness (T)	
HS20	.250 (6.35)	.220 (5.59)	.200 (5.08)	.170 (4.32)
HS21	.320 (8.13)	.280 (7.11)	.250 (6.35)	.220 (5.59)
HS22	.370 (9.40)	.300 (7.62)	.250 (6.35)	.275 (6.98)
HS30	.450 (11.43)	.220 (5.59)	.200 (5.08)	.300 (7.62)
HS23	.470 (11.94)	.400 (10.16)	.270 (6.89)	.375 (9.52)
HS31	.550 (13.97)	.280 (7.11)	.250 (6.35)	.400 (10.16)
HS24	.570 (14.48)	.500 (12.70)	.270 (6.89)	.475 (12.06)
HS25	.670 (17.02)	.600 (15.24)	.270 (6.89)	.575 (14.60)
HS26	.770 (19.56)	.720 (18.29)	.270 (6.89)	.675 (17.14)
HS33	.850 (21.59)	.400 (10.16)	.270 (6.89)	.700 (17.78)
HS34	1.050 (26.67)	.500 (12.70)	.270 (6.89)	.975 (24.76)
HS35	1.250 (31.75)	.600 (15.24)	.270 (6.89)	1.175 (29.84)
HS36	1.450 (36.83)	.720 (18.29)	.270 (6.89)	1.375 (34.92)

C0G (NP0), X7R DIELECTRIC CAPACITANCE RANGES

Style	500 VDC		1k VDC		2k VDC		3k VDC		4k VDC		5k VDC		7.5k VDC		10k VDC	
	C0G (NP0)	X7R	C0G (NP0)	X7R	C0G (NP0)	X7R	C0G (NP0)	X7R	C0G (NP0)	X7R	C0G (NP0)	X7R	C0G (NP0)	X7R	C0G (NP0)	X7R
	Max.	Max.	Max.	Max.	Max.	Max.	Max.	Max.	Max.	Max.	Max.	Max.	Max.	Max.	Max.	Max.
HS20	4700pF	.027µF	2200pF	6800pF	560pF	1200pF	---	---	---	---	---	---	---	---	---	---
HS21	.010µF	.082µF	5600pF	.022µF	1200pF	4700pF	---	---	---	---	---	---	---	---	---	---
HS22	.012µF	.100µF	5600pF	.027µF	1500pF	6800pF	---	---	---	---	---	---	---	---	---	---
HS23	.033µF	.270µF	.018µF	.082µF	2700pF	.015µF	1800pF	5600pF	---	---	---	---	---	---	---	---
HS24	.056µF	.470µF	.033µF	.150µF	5600pF	.027µF	3900pF	.012µF	1000pF	4700pF	5600pF	---	---	---	---	---
HS25	.100µF	.680µF	.047µF	.220µF	.010µF	.047µF	6800pF	.022µF	1800pF	8200pF	1500pF	4700pF	---	---	---	---
HS26	.150µF	1.00µF	.068µF	.330µF	.015µF	.068µF	.010µF	.033µF	2700pF	.012µF	2200pF	8200pF	---	---	---	---
HS30	.012µF	.082µF	5600pF	.018µF	560pF	3300pF	390pF	1200pF	---	---	---	---	---	---	---	---
HS31	.022µF	.150µF	.012µF	.047µF	1200pF	.010µF	820pF	3900pF	560pF	2200pF	2500pF	---	---	---	---	---
HS33	.082µF	.680µF	.047µF	.220µF	3900pF	.033µF	2700pF	.015µF	1500pF	6800pF	1200pF	3900pF	---	4700pF	---	---
HS34	.100µF	1.00µF	.068µF	.270µF	8200pF	.068µF	5600pF	.027µF	3300pF	.015µF	2200pF	8200pF	820pF	3300pF	---	---
HS35	.120µF	1.50µF	.100µF	.470µF	.012µF	.100µF	8200pF	.047µF	4700pF	.022µF	3900pF	.012µF	1200pF	.015µF	1000pF	3300pF
HS36	.180µF	2.20µF	.150µF	.680µF	.018µF	.150µF	.012µF	.068µF	8200pF	.033µF	.039µF	.022µF	2200pF	8200pF	1500pF	5600pF

PART NUMBER AND ORDERING INFORMATION

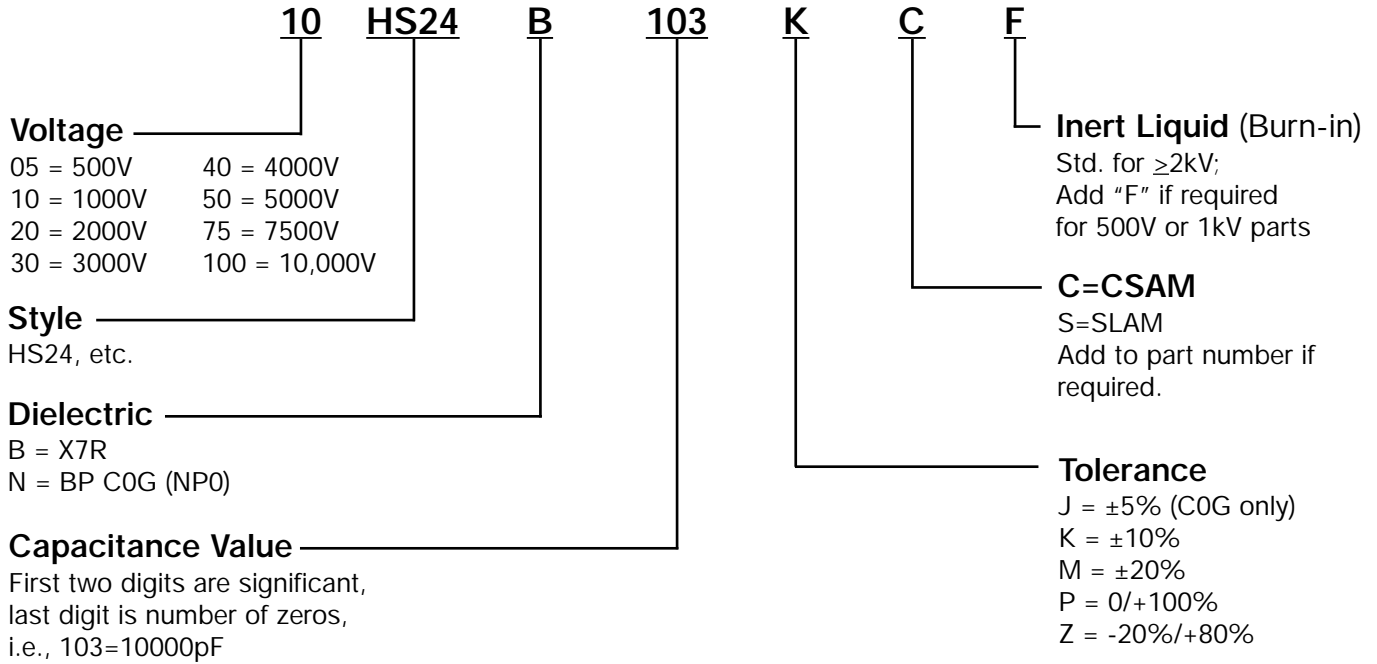

MARKING	
<u>(HS20, HV21)</u>	<u>(All Other Sizes)</u>
103K	HS24B103K
1 kV	1 kV
KEC	KEC
Date Code	Date Code

High Voltage Ceramic Chip (+125°C) Military Equivalent

FEATURES

1. The ceramic chip capacitors described in this section are the types used in our other high voltage ceramic multilayer product lines.
2. Types BP, BR and BZ available as described in MIL-PRF-49467.
3. Group A and B screening per MIL-PRF-49467 available.
4. Ceramic chip capacitors are extremely sensitive to thermal shock damage during installation. Wherever possible, processes involving infrared or vapor phase soldering systems should be utilized.
5. Higher voltages available upon request
6. Where nickel barrier termination is required, end band length dimensions may exceed the standard dimension listed.

CERAMIC CHIP OUTLINE DRAWING

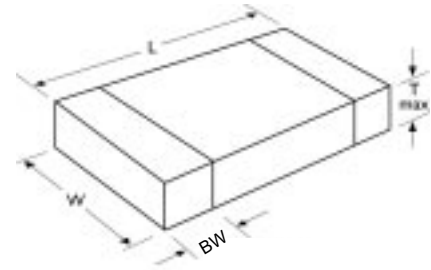

DIMENSIONS

Style	Length (L) Inches (mm)	Width (W) Inches (mm)	Thickness (T) Inches (mm)	Bandwidth (BW) Inches
1515	.150 ±.015 (3.81 ±.38)	.150 ±.015 (3.81 ±.38)	.140 (3.55)	.010 - .030"
1812	.180 ±.020 (4.57 ±.51)	.120 ±.015 (3.05 ±.38)	.100 (2.54)	.010 - .040"
1825	.180 ±.020 (4.57 ±.51)	.250 ±.020 (6.35 ±.51)	.160 (4.07)	.010 - .040"
2020	.200 ±.020 (5.08 ±.51)	.200 ±.020 (5.08 ±.51)	.180 (3.55)	.010 - .040"
2225	.220 ±.020 (5.59 ±.51)	.250 ±.020 (6.35 ±.51)	.200 (5.08)	.010 - .040"
2520	.250 ±.020 (6.35 ±.51)	.200 ±.020 (5.08 ±.51)	.180 (4.57)	.030 - .060"
3333	.330 ±.030 (8.38 ±.76)	.330 ±.030 (8.38 ±.76)	.220 (5.59)	.030 - .060"
3530	.350 ±.030 (8.89 ±.76)	.300 ±.030 (7.62 ±.76)	.220 (5.59)	.030 - .060"
4040	.400 ±.030 (10.2 ±.76)	.400 ±.030 (10.2 ±.76)	.220 (5.59)	.030 - .060"
4540	.450 ±.030 (11.43 ±.76)	.400 ±.030 (10.2 ±.76)	.220 (5.59)	.030 - .060"
5440	.540 ±.030 (13.7 ±.76)	.400 ±.030 (10.2 ±.76)	.220 (5.59)	.030 - .060"
5550	.550 ±.030 (14.0 ±.76)	.500 ±.030 (12.7 ±.76)	.220 (5.59)	.030 - .060"
6560	.650 ±.030 (16.5 ±.76)	.600 ±.030 (15.2 ±.76)	.220 (5.59)	.030 - .060"

RECOMMENDED SOLDER PAD PATTERN DIMENSIONS

Chip Size	T (Total Length)		S (Separation)		W (Pad Width)		L (Pad Length)	
	mm	in.	mm	in.	mm	in.	mm	in.
1515	5.20	0.205	1.90	0.075	4.34	0.171	1.65	0.065
1812	5.90	0.232	2.30	0.091	3.70	0.146	1.80	0.071
1825	5.90	0.232	2.30	0.091	6.90	0.272	1.80	0.071
2020	6.50	0.256	2.80	0.110	5.62	0.221	1.85	0.073
2225	7.00	0.276	3.30	0.130	6.80	0.268	1.85	0.073
2520	8.68	0.342	4.98	0.196	5.62	0.221	1.85	0.073
3333	10.91	0.430	7.11	0.280	9.27	0.365	1.90	0.075
3530	11.51	0.453	7.61	0.300	8.51	0.335	1.95	0.077
4040	12.88	0.507	8.88	0.350	11.05	0.435	2.00	0.079
4540	14.21	0.559	10.15	0.400	11.05	0.435	2.03	0.080
5440	16.51	0.650	10.41	0.410	11.05	0.435	3.05	0.120
5550	18.92	0.745	12.82	0.505	13.59	0.535	3.05	0.120
6560	19.80	0.780	13.20	0.520	16.13	0.635	3.30	0.130

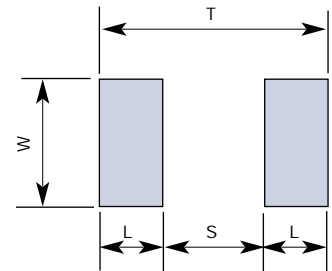

PART NUMBER AND ORDERING INFORMATION

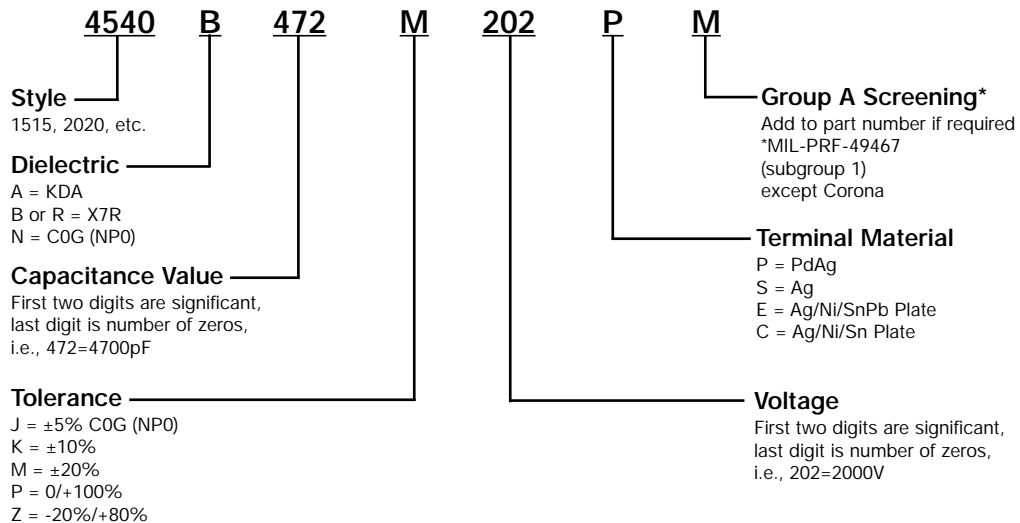

MARKING
Not applicable
As required by
customer only.

High Voltage Ceramic Chip (+125°C) Military Equivalent



C0G (NP0), X7R DIELECTRIC CAPACITANCE RANGES

Style	500 VDC		1k VDC		2k VDC		3k VDC		4k VDC		5k VDC	
	Min.	Max.	Min.	Max.	Min.	Max.	Min.	Max.	Min.	Max.	Min.	Max.
1515	27pF	4700pF	27pF	1500pF	12pF	680pF	12pF	150pF	---	---	---	---
1812	27pF	2700pF	27pF	1200pF	12pF	470pF	12pF	120pF	---	---	---	---
1825	39pF	8200pF	39pF	3900pF	22pF	820pF	22pF	560pF	---	---	---	---
2020	39pF	8200pF	39pF	3900pF	22pF	820pF	22pF	560pF	---	---	---	---
2225	47pF	.012μF	47pF	8200pF	27pF	1200pF	27pF	680pF	---	---	---	---
2520	47pF	.010μF	47pF	6800pF	27pF	1200pF	27pF	680pF	---	---	---	---
3333	120pF	.015μF	120pF	.012μF	47pF	2700pF	47pF	1200pF	27pF	680pF	---	---
3530	120pF	.022μF	120pF	.018μF	47pF	3300pF	47pF	1500pF	27pF	680pF	---	---
4040	220pF	.039μF	220pF	.022μF	100pF	5600pF	100pF	2200pF	18pF	1200pF	---	---
4540	220pF	.056μF	220pF	.033μF	100pF	6800pF	100pF	3900pF	18pF	1500pF	18pF	1000pF
5440	390pF	.082μF	390pF	.033μF	150pF	8200pF	150pF	3300pF	27pF	2200pF	---	---
5550	390pF	.068μF	390pF	.047μF	150pF	.010μF	150pF	6800pF	27pF	2200pF	27pF	2200pF
6560	470pF	.100μF	470pF	.068μF	270pF	.022μF	270pF	8200pF	47pF	3900pF	47pF	2700pF

X7R DIELECTRIC CAPACITANCE RANGES

Style	500 VDC		1k VDC		2k VDC		3k VDC		4k VDC		5k VDC	
	Min.	Max.	Min.	Max.	Min.	Max.	Min.	Max.	Min.	Max.	Min.	Max.
1515	680pF	.068μF	680pF	.022μF	270pF	3900pF	---	---	---	---	---	---
1812	680pF	.056μF	680pF	.018μF	270pF	2500pF	---	---	---	---	---	---
1825	1200pF	.180μF	1200pF	.047μF	560pF	8200pF	560pF	2700pF	---	---	---	---
2020	1200pF	.180μF	1200pF	.068μF	560pF	8200pF	560pF	3900pF	---	---	---	---
2225	1200pF	.220μF	1200pF	.068μF	680pF	.015μF	680pF	4700pF	---	---	---	---
2520	1200pF	.220μF	1200pF	.082μF	680pF	.018μF	680pF	5600pF	---	---	---	---
3333	3300pF	.470μF	3300pF	.250μF	1200pF	.027μF	1200pF	.012μF	---	---	---	---
3530	3300pF	.560μF	3300pF	.270μF	1200pF	.033μF	1200pF	.015μF	270pF	6800pF	---	---
4040	6800pF	.860μF	6800pF	.390μF	2700pF	.047μF	2700pF	.018μF	470pF	8600pF	---	---
4540	6800pF	1.20μF	6800pF	.470μF	2700pF	.068μF	2700pF	.033μF	470pF	.010μF	470pF	6800pF
5440	.010μF	1.50μF	.010μF	.680μF	3900pF	.056μF	3900pF	.012μF	680pF	.010μF	---	---
5550	.010μF	1.80μF	.010μF	.820μF	3900pF	.120μF	3900pF	.039μF	680pF	.015μF	680pF	.010μF
6560	.015μF	2.50μF	.015μF	1.00μF	6800pF	.180μF	6800pF	.082μF	1200pF	.027μF	1200pF	.015μF

KDA DIELECTRIC CAPACITANCE RANGES

Style	500 VDC		1k VDC		2k VDC		3k VDC		4k VDC		5k VDC	
	Min.	Max.	Min.	Max.	Min.	Max.	Min.	Max.	Min.	Max.	Min.	Max.
1515	220pF	.018μF	220pF	.012μF	100pF	2200pF	---	---	---	---	---	---
2020	390pF	.047μF	390pF	.033μF	180pF	5600pF	180pF	3900pF	---	---	---	---
2520	390pF	.068μF	390pF	.039μF	220pF	.010μF	220pF	4700pF	---	---	---	---
3530	1000pF	.150μF	1000pF	.10μF	390pF	.018μF	390pF	.012μF	820pF	3900pF	---	---
4540	1800pF	.27μF	1800pF	.18μF	820pF	.039μF	820pF	.022μF	150pF	6800pF	150pF	5600pF
5550	3300pF	.47μF	3300pF	.27μF	1200pF	.056μF	1200pF	.039μF	220pF	.01μF	220pF	8200pF
6560	3900pF	.680μF	3900pF	.47μF	2200pF	.100μF	2200pF	.056μF	3900pF	.018μF	390pF	.015μF

High Voltage Ceramic Chip (+125°C) Commercial

FEATURES

KEMET's High Voltage Surface Mount Capacitors are designed to withstand high voltage applications. They offer high capacitance with low leakage current and low ESR at high frequency. The capacitors have pure tin (Sn) plated external electrodes for good solderability. X7R dielectrics are not designed for AC line filtering applications. An insulating coating may be required to prevent surface arcing. These components are RoHS compliant.

CAPACITOR OUTLINE DRAWING

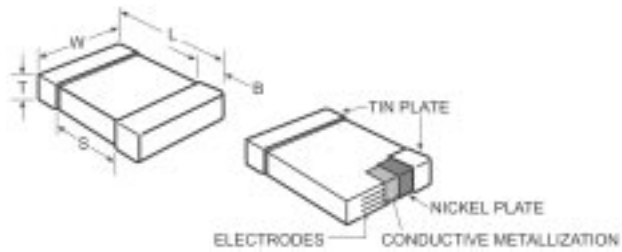

MARKETS

- Power Supply
- High Voltage Power Supply
- DC-DC Converter
- LCD Fluorescent Backlight Ballast
- HID Lighting
- Telecommunications Equipment
- Industrial Equipment/Control
- Medical Equipment/Control
- Computer (LAN/WAN Interface)
- Analog and Digital Modems
- Automotive

APPLICATIONS

- Switch Mode Power Supply
 - Input Filter
 - Tank Circuit
 - Output Filter
- High Voltage Coupling
- High Voltage DC Blocking
- Lighting Ballast
- Voltage Multiplier Circuits
- Coupling Capacitor/CUK
- Resonators
- Snubber Circuit

DIMENSIONS

Metric Code	EIA Size Code	L - Length	W - Width	B - Band Width	Band Separation
2012	0805	2.0 (0.079) ± 0.2 (0.008)	1.2 (0.049) ± 0.2 (0.008)	0.5 (0.02) ±0.25 (0.010)	0.75 (0.030)
3216	1206	3.2 (0.126) ± 0.2 (0.008)	1.6 (0.063) ± 0.2 (0.008)	0.5 (0.02) ± 0.25 (0.010)	N/A
3225	1210	3.2 (0.126) ± 0.2 (0.008)	2.5 (0.098) ± 0.2 (0.008)	0.5 (0.02) ± 0.25 (0.010)	N/A
4520	1808	4.5 (0.177) ± 0.3 (0.012)	2.0 (0.079) ± 0.2 (0.008)	0.6 (0.024) ± 0.35 (0.014)	N/A
4532	1812	4.5 (0.177) ± 0.3 (0.012)	3.2 (0.126) ± 0.3 (0.012)	0.6 (0.024) ± 0.35 (0.014)	N/A
4564	1825	4.5 (0.177) ± 0.3 (0.012)	6.4 (0.250) ± 0.4 (0.016)	0.6 (0.024) ± 0.35 (0.014)	N/A
5650	2220	5.6 (0.224) ± 0.4 (0.016)	5.0 (0.197) ± 0.4 (0.016)	0.6 (0.024) ± 0.35 (0.014)	N/A
5664	2225	5.6 (0.224) ± 0.4 (0.016)	6.4 (0.250) ± 0.4 (0.016)	0.6 (0.024) ± 0.35 (0.014)	N/A

CAPACITOR ORDERING INFORMATION

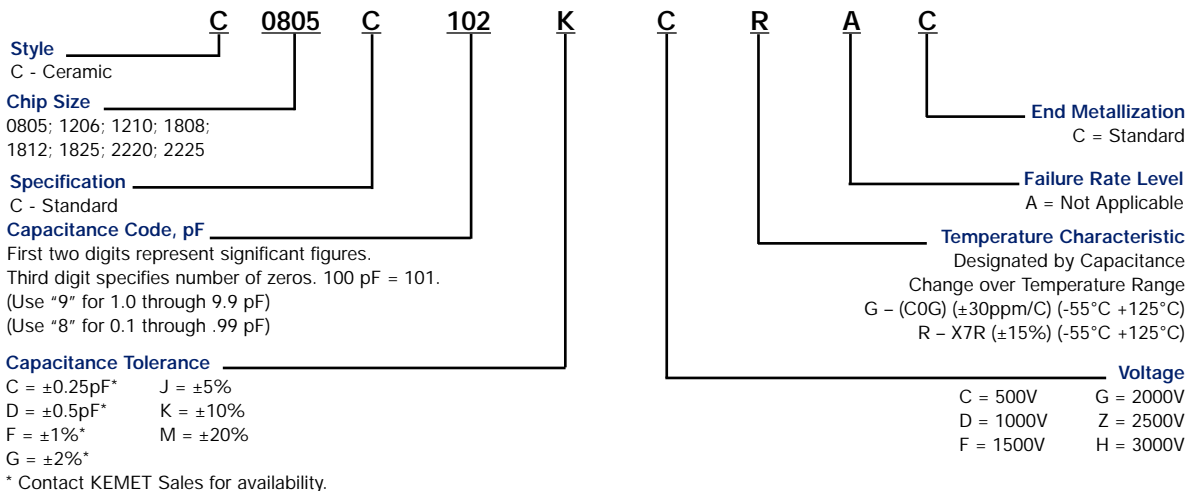



High Voltage Ceramic Chip (+125°C) Commercial

X7R DIELECTRIC CAPACITANCE VALUES AND THICKNESS TARGETS (IN.)

Cap pF	Capacitance Tolerance	Series	0805		1206			1210			1808			1812			1825			2220			2225					
			Max Thickness (in)	Cap Code/ Voltage	500	1000	500	1000	1500	2000	500	1000	1500	2000	2500	3000	500	1000	1500	2000	2500	3000	500	1000	1500	2000	2500	3000
			0.05	0.05	0.065	0.065	0.065	0.065	0.08	0.08	0.08	0.08	0.08	0.08	0.08	0.067	0.067	0.067	0.067	0.067	0.067	0.067	0.067	0.067	0.067	0.067	0.067	0.067
10	J,K,M	100																										
11	J,K,M	110																										
12	J,K,M	120																										
13	J,K,M	130																										
15	J,K,M	150																										
16	J,K,M	160																										
18	J,K,M	180																										
20	J,K,M	200																										
22	J,K,M	220																										
24	J,K,M	240																										
27	J,K,M	270																										
30	J,K,M	300																										
33	J,K,M	330																										
36	J,K,M	360																										
39	J,K,M	390																										
43	J,K,M	430																										
47	J,K,M	470																										
51	J,K,M	510																										
56	J,K,M	560																										
62	J,K,M	620																										
68	J,K,M	680																										
75	J,K,M	750																										
82	J,K,M	820																										
91	J,K,M	910																										
100	J,K,M	101																										
110	J,K,M	111																										
120	J,K,M	121																										
130	J,K,M	131																										
150	J,K,M	151																										
180	J,K,M	181																										
220	J,K,M	221																										
270	J,K,M	271																										
330	J,K,M	331																										
390	J,K,M	391																										
470	J,K,M	471																										
560	J,K,M	561																										
680	J,K,M	681																										
820	J,K,M	821																										
1000	J,K,M	102																										
1200	J,K,M	122																										
1500	J,K,M	152																										
1800	J,K,M	182																										
2200	J,K,M	222																										
2700	J,K,M	272																										
3300	J,K,M	332																										
3900	J,K,M	392																										
4700	J,K,M	472																										
5600	J,K,M	562																										
6800	J,K,M	682																										
8200	J,K,M	822																										
10,000	J,K,M	103																										
12,000	J,K,M	123																										
15,000	J,K,M	153																										
18,000	J,K,M	183																										
22,000	J,K,M	223																										
27,000	J,K,M	273																										
33,000	J,K,M	333																										
39,000	J,K,M	393																										
47,000	J,K,M	473																										
56,000	J,K,M	563																										
62,000	J,K,M	623																										
68,000	J,K,M	683																										
82,000	J,K,M	823																										
100,000	J,K,M	104																										
120,000	J,K,M	124																										
150,000	J,K,M	154																										
180,000	J,K,M	184																										
220,000	J,K,M	224																										

Note: Actual thickness dimensions may be less than stated maximum. Check the KEMET website, www.kemet.com, for additional values and chip sizes available.

High Voltage Ceramic Chip (+125°C) Commercial



ELECTRICAL PARAMETERS

Property	Specification
Capacitance	C0G: 1 pF to 0.010 μ F X7R: 10 pF to 0.22 μ F 25°C, 1.0 \pm 0.2 Vrms, 1 kHz (1 MHz for \geq 1000 pF (C0G only))
Cap Tolerance	C0G: C*, D*, F*, G*, J, K, M * Contact KEMET Sales for availability. X7R: J, K, M
DF	C0G: 0.1% Max X7R: 2.5% Max
Voltage Ratings	500 V, 1000 V, 1500 V, 2000 V, 2500 V, 3000 V
Operating Temperature Range	From -55C to +125C
25°C IR @ 500V	100 M Ω or 1000 M Ω - μ F, whichever is less
125°C IR @ 500V	10 M Ω or 100 M Ω - μ F, whichever is less
-55°C TCC +125°C TCC	X7R: + 15% C0G: + 30 ppm / °C
Dielectric Strength	150% of Rated Voltage for Rated Voltage <1000 V 120% of Rated Voltage for Rated Voltage \geq 1000V
Ripple Current	Consult KEMET Sales Representative

MARKING

These chips are supplied unmarked. If required, they can be supplied LASER-marked at an extra cost. Details on the marking format is included in KEMET Surface Mount Catalog F3102.

PACKAGING

KEMET High Voltage Surface Mount MLCC are available packaged in tape and reel configuration, or bulk bag as outlined in KEMET Surface Mount Catalog F3102. Please consult factory for waffle packaging options.

HV SMD MLCC Quantities Packaged Per Reel				
Chip Size		Tape Width (mm)	Qty. per Reel 7" Plastic	Qty. per Reel 13" Plastic
EIA	Metric			
0805	2012	8	2,500	10,000
1206	3216	8	2,000	8,000
1210	3225	8	2,000	8,000
1808	4520	12	2,000	4,000
1812	4532	12	1,000	4,000
1825	4564	12	1,000	4,000
2220	5650	12	1,000	4,000
2225	5664	12	1,000	4,000

SOLDERING PROCESS

The 0805 and 1206 case sizes are suitable for either reflow or wave soldering processes. Sizes 1210 and larger should be limited to reflow soldering only. All sizes incorporate the standard KEMET barrier layer of pure nickel with an overplating of pure tin (Sn) for excellent solderability and resistance to solder leaching of the termination. Please consult KEMET Surface Mount Catalog F3102 for further details on solder mounting as well as recommended solder pad dimensions.

RECOMMENDED SOLDER PAD DIMENSIONS

Chip Size	T (Total Length)		S (Separation)		W (Pad Width)		L (Pad Length)	
	mm	in.	mm	in.	mm	in.	mm	in.
0805	3.30	0.130	0.70	0.028	1.60	0.063	1.30	0.051
1206	4.50	0.177	1.50	0.059	2.00	0.079	1.50	0.059
1210	4.50	0.177	1.50	0.059	2.90	0.114	1.50	0.059
1808	5.90	0.232	2.30	0.091	2.40	0.094	1.80	0.071
1812	5.90	0.232	2.30	0.091	3.70	0.146	1.80	0.071
1825	5.90	0.232	2.30	0.091	6.90	0.272	1.80	0.071
2220	7.00	0.276	3.30	0.130	5.50	0.217	1.85	0.073
2225	7.00	0.276	3.30	0.130	6.80	0.268	1.85	0.073

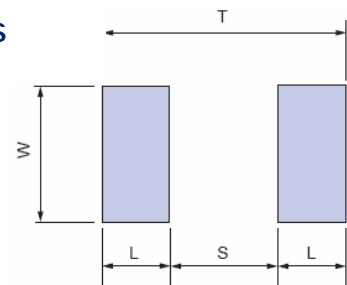

FEATURES

1. Silver plated copper alloy terminal for easy soldering.
2. Mounting tabs are designed to minimize the effect of thermal stress introduced by the differences in coefficient of thermal expansion between the capacitor and the mounting surface.
3. High density low DF ceramic.
4. Low ESR.
5. High current discharge capability.
6. KDA types non-piezoelectric and very low hysteresis.
7. Group A and B screening per MIL-PRF-49467 available .
8. Standard lead configuration is 'A'. If lead configuration is left out of part number the lead style is assumed to be 'A'.

CAPACITOR OUTLINE DRAWING

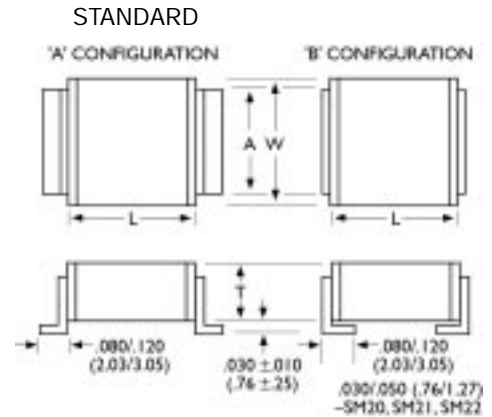

DIMENSIONS

Style	Length (L) Inches (mm)	Width (W) Inches (mm)	Thickness (T) Inches (mm)	Tab (A) Inches (mm)
SM20	.150 ± .015 (3.81 ± .38)	.150 ± .015 (3.81 ± .38)	.130 (3.30)	.100 (2.54)
SM21	.200 ± .020 (5.08 ± .51)	.200 ± .020 (5.08 ± .51)	.180 (4.57)	.100 (2.54)
SM22	.250 ± .020 (6.35 ± .51)	.200 ± .020 (5.08 ± .51)	.180 (4.57)	.100 (2.54)
SM23	.350 ± .030 (8.89 ± .76)	.300 ± .030 (7.62 ± .76)	.220 (5.59)	.200 (5.08)
SM24	.450 ± .030 (11.43 ± .76)	.400 ± .030 (10.20 ± .76)	.220 (5.59)	.300 (7.62)
SM25	.550 ± .030 (14.00 ± .76)	.500 ± .030 (12.70 ± .51)	.220 (5.59)	.400 (10.2)
SM26	.650 ± .030 (16.50 ± .76)	.600 ± .030 (15.20 ± .76)	.220 (5.59)	.500 (12.7)
SM30	.300 ± .030 (7.62 ± .76)	.150 ± .015 (3.81 ± .38)	.140 (3.55)	.100 (2.54)
SM31	.400 ± .030 (10.20 ± .76)	.200 ± .020 (5.08 ± .51)	.130 (3.30)	.100 (2.54)
SM33	.700 ± .030 (17.08 ± .76)	.300 ± .030 (7.62 ± .76)	.180 (4.57)	.200 (5.08)
SM34	.900 ± .030 (22.90 ± .76)	.400 ± .030 (10.20 ± .76)	.220 (5.59)	.300 (7.62)
SM35	.150 ± .030 (27.90 ± .76)	.500 ± .030 (12.70 ± .51)	.220 (5.59)	.400 (10.2)
SM36	1.350 ± .030 (33.00 ± .76)	.600 ± .030 (15.20 ± .76)	.220 (5.59)	.500 (12.7)

PART NUMBER AND ORDERING INFORMATION

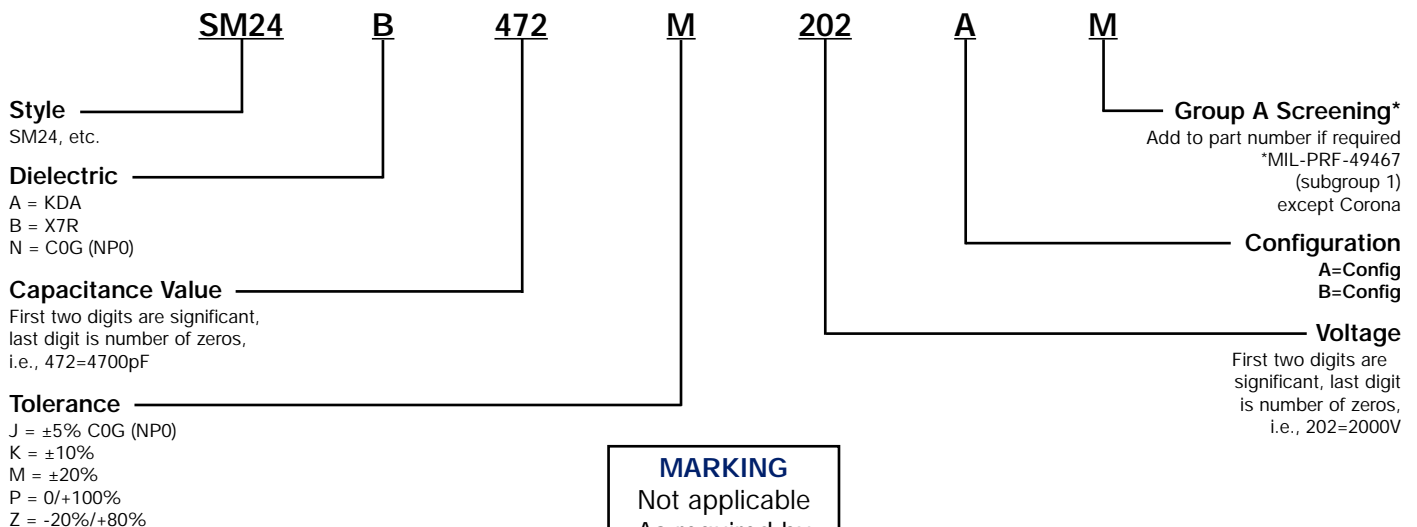

MARKING
Not applicable
As required by
customer only.

High Voltage Surface Mount Ceramic Capacitor SM Series



COG (NP0) DIELECTRIC CAPACITANCE RANGES

Style	500 VDC		1k VDC		2k VDC		3k VDC		4k VDC		5k VDC		7k VDC		10k VDC	
	Min.	Max.	Min .	Max.	Min .	Max.	Min .	Max.	Min .	Max.	Min .	Max.	Min .	Max.	Min .	Max.
SM20	27pF	4700pF	27pF	1500pF	12pF	680pF	12pF	150pF	---	---	---	---	---	---	---	---
SM21	39pF	8200pF	39pF	3900pF	22pF	820pF	22pF	560pF	---	---	---	---	---	---	---	---
SM22	47pF	.010μF	47pF	6800pF	27pF	1200pF	27pF	680pF	---	---	---	---	---	---	---	---
SM23	120pF	.022μF	120pF	.018μF	47pF	3300pF	47pF	1500pF	27pF	680pF	---	---	---	---	---	---
SM24	220pF	.056μF	220pF	.033μF	100pF	6800pF	100pF	3900pF	18pF	1500pF	27pF	1000pF	---	---	---	---
SM25	390pF	.082μF	390pF	.047μF	150pF	.010μF	150pF	6800pF	27pF	2200pF	18pF	2200pF	---	---	---	---
SM26	470pF	.10μF	470pF	.068μF	270pF	.022μF	270pF	8200pF	47pF	3900pF	47pF	2700pF	---	---	---	---
SM30	68pF	.015μF	68pF	4700pF	15pF	1000pF	15pF	390pF	10pF	220pF	---	---	---	---	---	---
SM31	82pF	.027μF	82pF	.010μF	27pF	2200pF	27pF	820pF	10pF	560pF	10pF	390pF	---	---	---	---
SM33	330pF	.120μF	330pF	.068μF	68pF	.010μF	68pF	4700pF	27pF	1500pF	27pF	1200pF	12pF	470pF	---	---
SM34	470pF	.150μF	470pF	.056μF	120pF	.015μF	120pF	5600pF	47pF	3300pF	47pF	2200pF	18pF	1000pF	18pF	680pF
SM35	680pF	.220μF	680pF	.10μF	220pF	.022μF	220pF	.015μF	82pF	5600pF	82pF	3900pF	33pF	1800pF	33pF	1200pF
SM36	1000pF	.330μF	1000pF	.15μF	270pF	.039μF	270pF	.018μF	120pF	8200pF	120pF	5600pF	56pF	2700pF	56pF	2200pF

X7R DIELECTRIC CAPACITANCE RANGES

Style	500 VDC		1k VDC		2k VDC		3k VDC		4k VDC		5k VDC		7k VDC		10k VDC	
	Min.	Max.	Min .	Max.	Min .	Max.	Min.	Max.	Min .	Max.	Min .	Max.	Min .	Max.	Min .	Max.
SM20	680pF	.082μF	680pF	.022μF	270pF	3900pF	---	---	---	---	---	---	---	---	---	---
SM21	1200pF	.180μF	1200pF	.068μF	560pF	8200pF	560pF	3900pF	---	---	---	---	---	---	---	---
SM22	1200pF	.220μF	1200pF	.082μF	680pF	.018μF	680pF	5600pF	---	---	---	---	---	---	---	---
SM23	3300pF	.560μF	3300pF	.270μF	1200pF	.033μF	1200pF	.015μF	270pF	6800pF	---	---	---	---	---	---
SM24	6800pF	1.20μF	6800pF	.470μF	2700pF	.068μF	2700pF	.033μF	470pF	.010μF	470pF	6800pF	---	---	---	---
SM25	.010μF	.180μF	.010μF	.820μF	3900pF	.120μF	3900pF	.039μF	680pF	.015μF	680pF	.010μF	---	---	---	---
SM26	.015μF	2.50μF	.015μF	1.00μF	6800pF	.180μF	6800pF	.082μF	1200pF	.027μF	1200pF	.015μF	---	---	---	---
SM30	1800pF	.220μF	1800pF	.056μF	390pF	5600pF	390pF	2200pF	150pF	1000pF	---	---	---	---	---	---
SM31	2700pF	.390μF	2700pF	.150μF	680pF	.022μF	680pF	3900pF	270pF	2200pF	270pF	1500pF	---	---	---	---
SM33	.010μF	1.50μF	.010μF	.560μF	1800pF	.082μF	1800pF	.027μF	680pF	.012μF	680pF	6800pF	220pF	3300pF	---	---
SM34	.012μF	2.20μF	.012μF	.820μF	3300pF	.150μF	3300pF	.047μF	1200pF	.027μF	1200pF	.022μF	470pF	6800pF	470pF	3900pF
SM35	.018μF	3.90μF	.018μF	1.20μF	5600pF	.250μF	5600pF	.082μF	2200pF	.039μF	2200pF	.027μF	820pF	8200pF	820pF	4700pF
SM36	.027μF	5.60μF	.027μF	1.80μF	8200pF	.390μF	8200pF	.120μF	3300pF	.056μF	3300pF	.039μF	1200pF	.018μF	1200pF	.010μF

KDA DIELECTRIC CAPACITANCE RANGES

Style	500 VDC		1k VDC		2k VDC		3k VDC		4k VDC		5k VDC		7k VDC		10k VDC	
	Min .	Max.	Min .	Max.	Min .	Max.	Min .	Max.	Min .	Max.	Min .	Max.	Min .	Max.	Min .	Max.
SM20	220pF	.018μF	220pF	.012μF	100pF	2200pF	---	---	---	---	---	---	---	---	---	---
SM21	390pF	.047μF	390pF	.033μF	180pF	6800pF	180pF	3900pF	---	---	---	---	---	---	---	---
SM22	390pF	.068μF	390pF	.039μF	220pF	.010μF	220pF	4700pF	---	---	---	---	---	---	---	---
SM23	1000pF	.15μF	1000pF	.10μF	390pF	.018μF	390pF	.010μF	82pF	3900pF	---	---	---	---	---	---
SM24	1800pF	.27μF	1800pF	.18μF	820pF	.039μF	820pF	.022μF	150pF	6800pF	150pF	5600pF	---	---	---	---
SM25	3300pF	.47μF	3300pF	.27μF	1200pF	.056μF	1200pF	.033μF	220pF	.010μF	220pF	8200pF	---	---	---	---
SM26	3900pF	.680μF	3900pF	.47μF	2200pF	.100μF	2200pF	.056μF	390pF	.018μF	390pF	.015μF	---	---	---	---
SM30	560pF	.056μF	560pF	.033μF	120pF	3900pF	120pF	2700pF	47pF	1000pF	---	---	---	---	---	---
SM31	820pF	.10μF	820pF	.068μF	220pF	.010μF	220pF	5600pF	82pF	3300pF	82pF	1200pF	---	---	---	---
SM33	2700pF	.39μF	2700pF	.270μF	560pF	.039μF	560pF	.025μF	220pF	8200pF	220pF	6800pF	82pF	1800pF	---	---
SM34	3900pF	.056μF	3900pF	.39μF	1200pF	.082μF	1200pF	.047μF	390pF	.018μF	390pF	.012μF	180pF	3300pF	180pF	1800pF
SM35	5600pF	1.00μF	5600pF	.56μF	1800pF	.12μF	1800pF	.082μF	680pF	.027μF	680pF	.022μF	270pF	5600pF	270pF	2700pF
SM36	8200pF	1.50μF	8200pF	.82μF	2200pF	.18μF	2200pF	.12μF	1000pF	.047μF	1000pF	.033μF	390pF	8200pF	390pF	4700pF

High Voltage Disc Ceramic Capacitor D Series

FEATURES

Disc ceramic capacitors made under strict quality control procedures are a reliable component. Special attention is given to the ceramic pressing operation to assure high and uniform ceramic density.

These parts are manufactured for the quality conscious customer. Parts are available screened to MIL-PRF-49467 established reliability specification.

CAPACITOR OUTLINE DRAWING

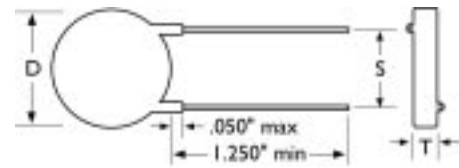

INSTALLATION

Higher-voltage parts may require further encapsulation to prevent surface breakdown. Parts should be cleaned and oven dried at 85°C before further encapsulation. Silicone rubbers or an epoxy may be used. De-airing of encapsulants is recommended. We recommend that a heat sink be attached to the lead between the soldering iron and the capacitor during installation soldering. Testing of higher-voltage parts before encapsulation may be done in a suitable dielectric fluid such as Freon.

DIELECTRIC COMPARISON

CERAMIC TYPE	C0G (NP0)	X7R	X5U
Dissipation Factor	0.1%	2.5%	2.5%
Temperature Coefficient	±30ppm/°C	±15%	+22% -56%
Voltage Coefficient	0	-20%	N/A
Dielectric Withstanding Voltage Test	3 to 15kV at 1.5x rated, 20 to 50kV at rated +10kV	3 to 15kV at 1.5x rated, 20 to 50kV at rated +10kV	3 to 15kV at 1.5x rated, 20 to 50kV at rated +10kV
Insulation Resistance (25°C)	100k megohms or 1k megohms-μF, whichever is less	100k megohms or 1k megohms-μF, whichever is less	10k megohms or 100 megohms-μF, whichever is less
Operating Temperature Range (rated voltage)	-55°C to +125°C	-55°C to +125°C	-55°C to +125°C

Thickness:
Inches (mm) max.

3kV	= 0.15 (3.81)
5kV	= 0.20 (5.08)
7.5kV	= 0.28 (7.11)
10kV	= 0.35 (8.89)
15kV	= 0.45 (11.43)
20kV	= 0.55 (13.97)
30kV	= 0.95 (24.13)
40kV	= 1.20 (30.48)
50kV	= 1.50 (38.10)

Lead Type: Solder plated, copper-clad steel (CCFE)-
D30, D40: 0.025" (22GA)
D50 & Larger: 0.032" (20GA)

PART NUMBER AND ORDERING INFORMATION

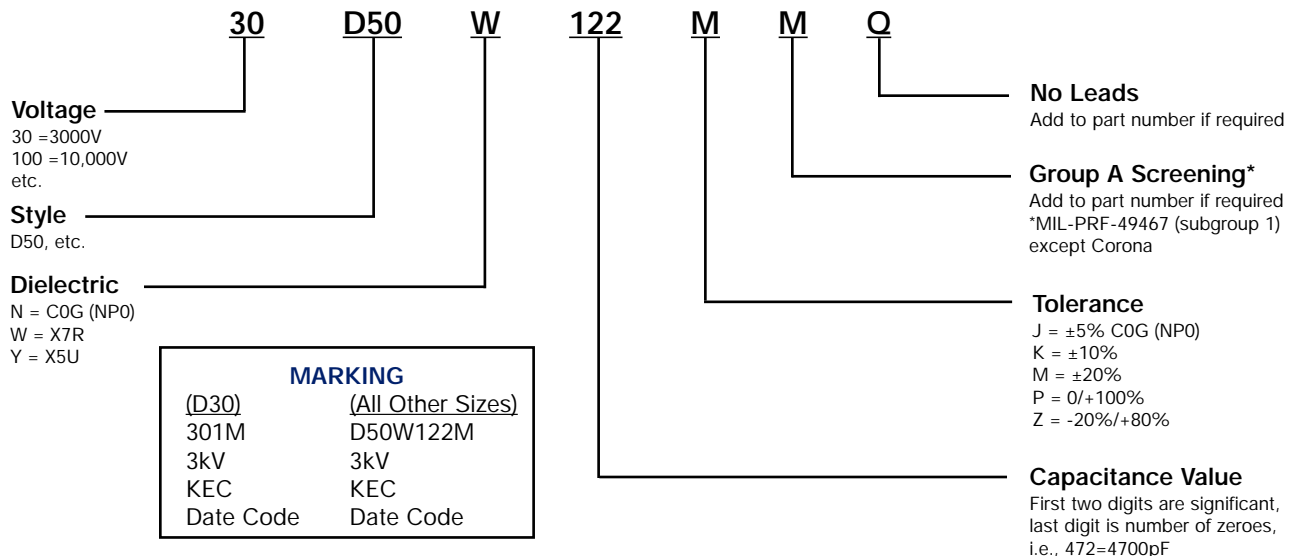

High Voltage Disc Ceramic Capacitor



D Series

3K VDC

Disc Style	D Max.	S ±.030	COG (NP0)		X7R		X5U	
			Min.	Max.	Min.	Max.	Min.	Max.
D30	.30	.250	7.8pF	9.6pF	250pF	300pF	520pF	700pF
D40	.40	.250	20pF	25pF	630pF	770pF	1300pF	1800pF
D50	.50	.375	36pF	44pF	1100pF	1400pF	2400pF	3200pF
D75	.75	.375	80pF	98pF	2500pF	3100pF	5300pF	7200pF
D90	.90	.500	123pF	150pF	3800pF	4700pF	8200pF	11000pF
D100	1.00	.500	145pF	178pF	4600pF	5600pF	9700pF	13000pF
D120	1.20	.500	193pF	236pF	6000pF	7400pF	12900pF	17300pF

5K VDC

D30	.30	.250	4.7pF	5.7pF	150pF	180pF	310pF	420pF
D40	.40	.250	12pF	15pF	380pF	460pF	810pF	1100pF
D50	.50	.375	21pF	26pF	670pF	820pF	1400pF	1900pF
D75	.75	.375	48pF	59pF	1500pF	1800pF	3200pF	4300pF
D90	.90	.500	74pF	90pF	2300pF	2800pF	4900pF	6600pF
D100	1.00	.500	87pF	107pF	2700pF	3300pF	5800pF	7800pF
D120	1.20	.500	116pF	141pF	3600pF	4400pF	7700pF	10400pF

7.5K VDC

D30	.30	.250	3.1pF	3.8pF	100pF	120pF	210pF	280pF
D40	.40	.250	8.1pF	9.9pF	250pF	310pF	540pF	720pF
D50	.50	.375	14pF	17pF	450pF	550pF	9950pF	1300pF
D75	.75	.375	32pF	39pF	1000pF	1200pF	2100pF	2900pF
D90	.90	.500	49pF	60pF	1500pF	1900pF	3300pF	4400pF
D100	1.00	.500	58pF	71pF	1800pF	2200pF	3900pF	5200pF
D120	1.20	.500	77pF	94pF	2400pF	3000pF	5100pF	6900pF

10K VDC

D30	.30	.250	2.4pF	2.9pF	70pF	90pF	160pF	210pF
D40	.40	.250	6.1pF	7.4pF	190pF	230pF	400pF	540pF
D50	.50	.375	10.7pF	13.1pF	330pF	410pF	710pF	960pF
D75	.75	.375	24pF	29pF	750pF	920pF	1600pF	2200pF
D90	.90	.500	37pF	45pF	1200pF	1400pF	2500pF	3300pF
D100	1.00	.500	44pF	53pF	1400pF	1700pF	2900pF	3900pF
D120	1.20	.500	58pF	71pF	1800pF	2200pF	3900pF	5200pF

15K VDC

D30	.30	.250	1.6pF	1.9pF	50pF	60pF	100pF	140pF
D40	.40	.250	4.0pF	4.9pF	130pF	150pF	270pF	360pF
D50	.50	.375	7.1pF	8.7pF	220pF	270pF	480pF	640pF
D75	.75	.375	16pF	20pF	500pF	610pF	1100pF	1400pF
D90	.90	.500	25pF	30pF	770pF	940pF	1600pF	2200pF
D100	1.00	.500	29pF	36pF	910pF	1100pF	1900pF	2600pF
D120	1.20	.500	39pF	47pF	1200pF	1500pF	2600pF	3500pF

20K VDC

D30	.30	.250	1.2pF	1.4pF	37pF	45pF	80pF	110pF
D40	.40	.250	3.0pF	3.7pF	100pF	120pF	200pF	270pF
D50	.50	.375	5.3pF	6.5pF	170pF	200pF	360pF	480pF
D75	.75	.375	12pF	15pF	380pF	460pF	800pF	1100pF
D90	.90	.500	18pF	22pF	580pF	700pF	1200pF	1600pF
D100	1.00	.500	22pF	27pF	680pF	830pF	1500pF	2000pF
D120	1.20	.500	29pF	35pF	910pF	1100pF	1900pF	2600pF

30K, 40K & 50K VDC

Disc Style	D Max.	S ±.030	30kVDC		40kVDC		50kVDC	
			X7R		X7R		X7R	
			Min.	Max.	Min.	Max.	Min.	Max.
D30	.30	.250	20pF	30pF	18pF	22pF	10pF	20pF
D40	.40	.250	60pF	80pF	50pF	60pF	40pF	50pF
D50	.50	.375	110pF	140pF	80pF	100pF	70pF	80pF
D75	.75	.375	250pF	310pF	190pF	230pF	150pF	180pF
D90	.90	.500	380pF	470pF	290pF	350pF	230pF	280pF
D100	1.00	.500	460pF	560pF	340pF	420pF	270pF	330pF
D120	1.20	.500	600pF	740pF	450pF	550pF	360pF	440pF

FEATURES

1. Special lead configurations available.
2. Custom designs are available upon request.

D dimension - See previous page for capacitance/voltage desired and resulting diameter.

CAPACITOR OUTLINE DRAWING

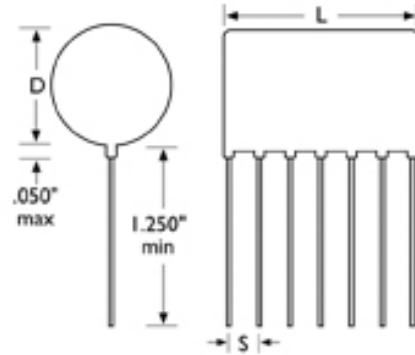

L DIMENSION INCHES (MM) MAX.

Number of Selections	Voltage per Section				
	5k VDC	7.5k VDC	10k VDC	15k VDC	20k VDC
2	.40 (10.16)	.50 (12.70)	.60 (15.24)	.90 (22.86)	1.00 (25.40)
3	.55 (13.97)	.70 (17.78)	.85 (21.59)	1.15 (29.21)	1.55 (39.07)
4	.70 (17.78)	.85 (21.59)	1.10 (27.94)	1.45 (36.83)	1.90 (48.26)
5	.80 (20.32)	1.10 (27.94)	1.30 (33.02)	1.80 (45.72)	2.30 (58.42)
6	.95 (24.13)	1.30 (33.02)	1.55 (39.07)	2.15 (54.61)	2.75 (69.85)
S ±0.030 (±.76)	.13 (3.30)	.18 (4.57)	.23 (5.84)	.33 (8.35)	.43 (10.92)

PART NUMBER AND ORDERING INFORMATION

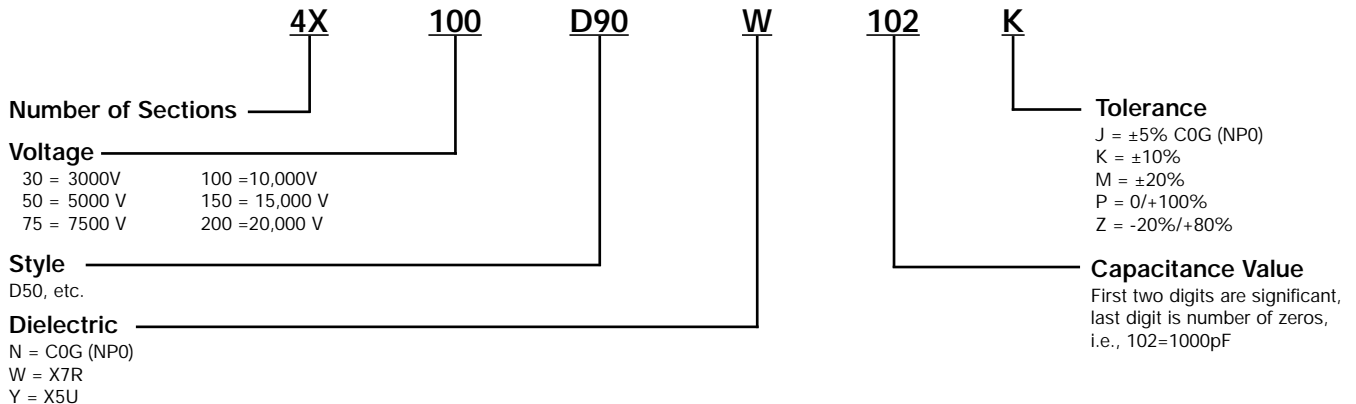

MARKING	
(D30)	(All Other Sizes)
301M	4XD50W122M
3kV	3kV
KEC	KEC
Date Code	Date Code

KEMET *Electronics Corporation*

World Sales Headquarters

P.O. Box 5928 • Greenville, SC 29606 • www.kemet.com

Phone: (864) 963-6300 • Fax: (864) 963-6521

USA/Canada Locations

KEMET Electronics Corporation
26 Corporate Plaza, Suite 170
Newport Beach, CA 92660
Phone: 949-640-9320
Fax: 949-720-9807

KEMET Electronics Corporation
2350 Mission College Blvd., Suite 972
Santa Clara, CA 95054
Phone: 408-986-0424
Fax: 408-986-1442

KEMET Electronics Corporation
Schaumburg Corporate Center
Suite 350, 1515 Woodfield Road
Schaumburg, IL 60173
Phone: 847-517-1030
Fax: 847-517-1037

KEMET Electronics Corporation
444 Washington Street, Suite 510
Woburn, MA 01801
Phone: 781-933-1010
Fax: 781-376-0929

KEMET Electronics Corporation
8445 Freeport Parkway, Suite 320
Irving, TX 75063
Phone: 972-870-9530
Fax: 972-870-9537

KEMET Electronics Canada Ltd.
105-7145 West Credit Ave., Bldg. #2
Mississauga, L5N 6J7, ON
Canada
Phone: 905-542-7930
Fax: 905-542-7949

KEMET Electronics Canada Ltd.
65 boul. Brunswick, Suite 214
Dollard-des-Ormeaux, H9B-2N4 QC
Canada
Phone: 514-685-3773
Fax: 514-685-4077

Europe Locations

KEMET Electronics S.A.
1-3, Avenue de la Paix
P.O.B. 76
CH-1211 Geneva 20,
Switzerland
Phone: 41-22-715-0100
Fax: 41-22-715-0170

KEMET Electronics GmbH
Elisabethstrasse 89-91
Munich D80797, Germany
Phone: 49-89-5908-2054
Fax: 49-89-5908-1304

KEMET Electronics Ltd.
Waterfront House, 55/61 South St.
Bishop's Stortford
Hertfordshire, CM23 3AL
United Kingdom
Phone: 44-1279-757343
Fax: 44-1279-757188

KEMET Electronics SA
Via Gaetano Ermoli
225C, F Int. 11
Rome, L-00155, Italy
Phone: 39-06-23231718
Fax: 39-06-23239519

KEMET Electronics S.A.R.L.
ZAC Paris Rive Gauche
118-122, avenue de France
75013 Paris, France
Phone: 01-33-01-464-61009
Fax: 01-33-01-464-61599

Asia Locations

KEMET Electronics (Shanghai) Co., Ltd.
2/F, No. 7 Bldg., 330 Xiya Rd.
Waigaoqiao Free Trade Zone
Pudong, Shanghai 200137, China
Phone: 86-21-5046-0983
Fax: 86-21-5046-0981

KEMET Electronics Asia Ltd.
Rm 605, Citic Bldg.
No. 19 Jian Guo Men Wai Da Jie
Beijing, 100004, China
Phone: 8610-8526-3628
Fax: 8610-8526-3626

KEMET Electronics Asia Ltd.
30 Canton Rd., Room 1512
Silvercord Tower II
Tsimshatshui, Kowloon Bay, Hong Kong
Phone: 852-2305-1168
Fax: 852-2759-0345

KEMET Electronics Marketing PTE Ltd.
8-2-04, Sunny Point Kompleks
Jalan Batu Uban, 11700 Penang
Penang, Malaysia
Phone: 60-4-6595200
Fax: 60-4-6595220

KEMET Electronics Marketing PTE Ltd.
101 Thomson Road, #23-03
United Square
Singapore, 307591, Singapore
Phone: 65-6353-6636
Fax: 65-6353-6656

KEMET Electronics Corporation
Taiwan Branch, 3-4F, No. 148, Section 4
Chung-Hsiao E. Rd.
Taipei, Taiwan ROC
Phone: 886-2-27528585
Fax: 886-2-27213129

WesTech Electronics & System Co. Ltd
302/12 Central Condominium
Ladproa Soil, Ladproa Road
Ladyao, Jatujak
Bangkok, Thailand 109000
Phone: 662-939-3482-6
Fax: 662-939-3481

Crusader Electronics Pty. Ltd.
Unit 3, 92 Bryant Street
Padstow, NSW 2211, Australia
Phone: 612-9792-3922
Fax: 612-9792-1446

Unicom International Corporation
702 Shinhwa Bldg., Mapo-Gu
Seoul, 121050, Korea
Phone: 82-2712-5821
Fax: 82-2712-5823

NOTICE: Place 011 in front of the above Phone and Fax numbers for Europe and Asia, when dialing from a United States exchange. Note: KEMET reserves the right to modify minor details of internal and external construction at any time in the interest of product improvement. KEMET does not any responsibility for infringement that might result from the use of KEMET Capacitors in potential circuit designs. © KEMET is a registered trademark of KEMET Electronics Corporation. © KEMET Electronics Corporation