

MAIN FEATURES

- High specific capacitance
- 0.022 Farad to 0.560 Farad
- Very low ESR down to 25 milliOhm
- Low profile: down to 2.1 mm height
- High power pulse capability
- Low Leakage current: Down to 5 micro Amperes
- Non-polar
- Foot prints 28x17 mm or 48x30 mm
- Voltage ratings 3.5V – 12V



GENERAL DESCRIPTION

The BestCap™ series of electrochemical supercapacitors offer excellent high power pulse characteristics based upon the combination of very high capacitance and ultra low ESR in the milliOhm region. Based on a unique patented aqueous polymer chemistry and an innovative design, the system offers high capacitance, even with short pulse duration regimes such as in GSM/GPRS based systems, together with a variety of voltage ratings.

APPLICATIONS

- GSM/GPRS wireless communication products
- ADSL / xDSL and other communication equipment
- Automatic meter reading systems
- Wireless alarm systems
- Memory back-up
- Mainframe computer de-coupling
- Hybrid battery packs
- Laser systems

TECHNICAL SPECIFICATIONS AND PART NUMBERS

All technical data relate to an ambient temperature of +25°C

Part number	Rated voltage	Capacitance Mili Farad +80%-20%	ESR (milliOhm) @1KHz	Leakage current (micro amps max.)	Dimensions (mm)	* Available terminals
BZ013B403Z_B	3.5V	40	140	5	28x17x2.1	S
BZ013A703Z_B		70	140	5	28x17x2.9	A,L, S
BZ013B803Z_B		80	70	10	28x17x3.8	A
BZ013A144Z_B		140	70	10	28x17x4.7	A,L
BZ015B303Z_B	5.5V	30	160	5	28x17x2.7	S
BZ015A503Z_B		50	160	5	28x17x3.5	A,L,S
BZ015B603Z_B		60	80	10	28x17x4.8	A,L
BZ015A104Z_B		100	80	10	28x17x6.1	A,L,S
BZ017A333Z_B	7V	33	225	5	28X17x4.5	S
BZ019A333Z_B	9V	33	250	5	28X17x4.9	S
BZ01CA223Z_B	12V	22	350	5	28X17x6.5	S
BZ023A284Z_B	3.5V	280	45	20	48x30x2.9	A,L
BZ023A564Z_B		560	25	40	48x30x4.7	A,L
BZ025A204Z_B	5.5V	200	60	20	48x30x3.5	A,L
BZ025A404Z_B		400	35	40	48x30x6.1	A,L

Note: For other voltage/capacitance/size, please contact your local AVX representative or sales office.

* See ordering information

HOW TO ORDER

BZ
|
BESTCAP™

01
|
CASE SIZE
01=28mmx17mm
02=48mmx30mm

5
|
VOLTAGE
5=5.5V
3=3.5V
7=7.0V
9=9.0V
C=12.0V

A
|
SERIES

503
|

CAPACITANCE VALUE(μF)
First two numbers express the significant digits;
the third number refers to the number of zeros.
Example: 503 → 50,000μF = 0.050 Farad.

Z
|
CAPACITANCE TOLERANCE
Z=+80%, -20%

A
|
TERMINATION STYLE
Where:
A = Through Hole
L, S = SMT

B
|
PACKAGE CODE
B = Bulk

XX
|
SPECIAL CUSTOMER REQUEST

Example: BZ015A503ZAB 5.5V, 50mF, 28mm x 17mm case, terminals type A.

BESTCAP™: A NEW GENERATION OF PULSE SUPERCAPACITORS

Supercapacitors, (also referred to as Electrochemical Capacitors or Double Layer Capacitors) have rapidly become recognized, not only as an excellent compromise between "electronic" capacitors such as ceramic, tantalum, film and aluminium electrolytic, and batteries (Fig. 1), but also as a valuable technology for providing a unique combination of characteristics, particularly very high energy, power and capacitance densities.

Fig. 1 Specific Energy of Capacitor Types

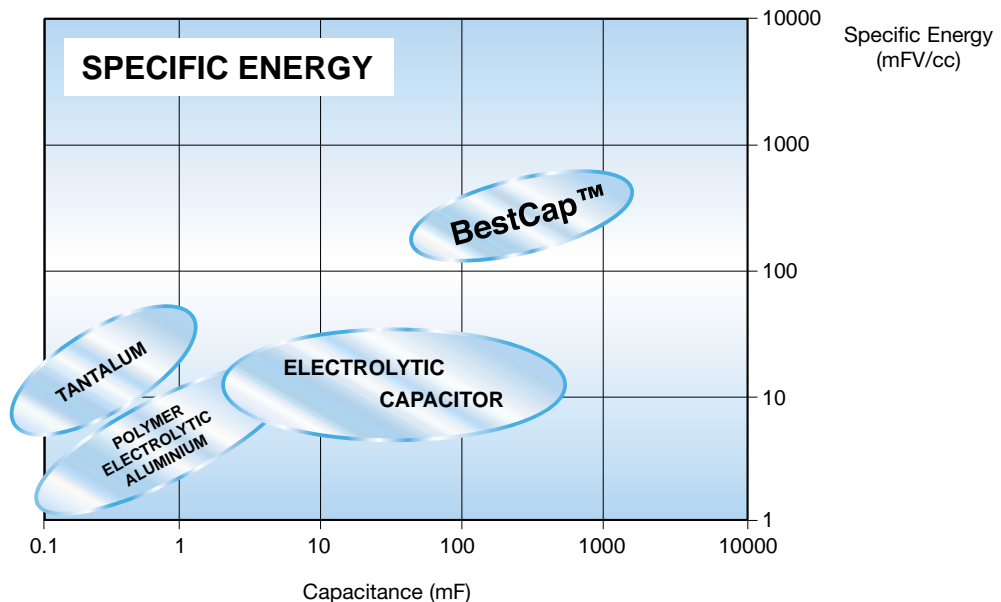

There are two negative characteristics associated with conventional supercapacitors: high ESR in the Ohms or tens of Ohms area, and severe capacitance loss when called upon to supply very short duration current pulses. BestCap™ successfully addresses both of these drawbacks.

This capacitance loss in the millisecond region is caused by the charge transfer (i.e. establishment of capacitance) being carried out by relatively slow moving ions in double layer capacitors. In the above-mentioned "electronic" capacitors the charge transfer is performed by fast electrons, thereby creating virtually instant rated capacitance value. Fig. 2 illustrates the severe capacitance loss experienced by several varieties of supercapacitors under short pulse width conditions. It can also be seen from Fig. 2, how well BestCap™ retains its capacitance with reducing pulse widths.

Fig. 2 Actual capacitance vs. pulse width

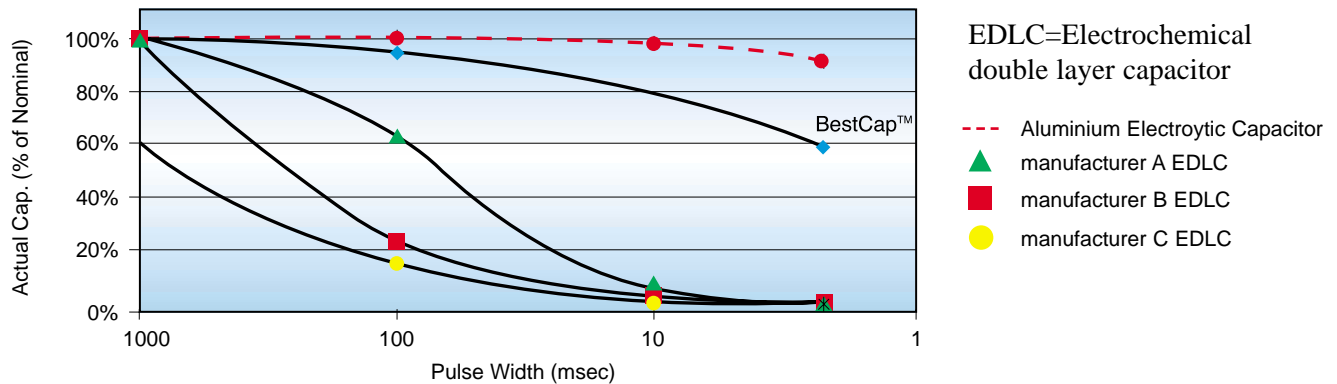

VOLTAGE DROP

Two factors are critical in determining voltage drop when a capacitor delivers a short current pulse; these are ESR and "available" capacitance as shown in Fig. 4.

Fig 4 Voltage-time relation of capacitor unit

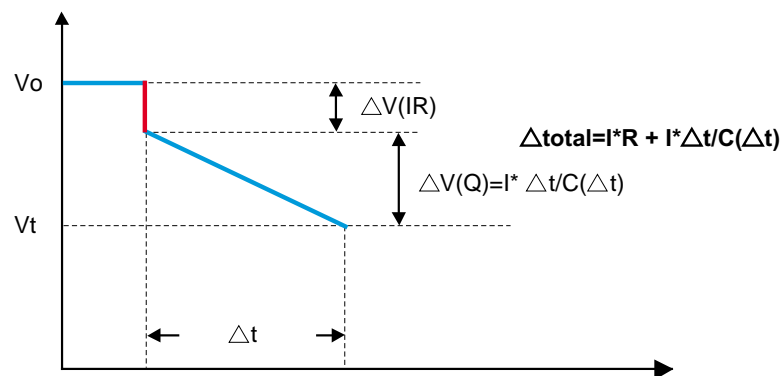

The instant voltage drop $V(IR)$ is caused by and is directly proportional to the capacitor's ESR. The continuing voltage drop with time $V(Q)$, is a function of the available charge, i.e. capacitance. From figures 3 and 4, it is apparent that for very short current pulses e.g. in the millisecond region, the combination of voltage drops in a conventional supercapacitor caused by a) the high ESR and b) the lack of available capacitance, causes a total voltage drop unacceptable for most applications. Now compare the BestCap™ performance under such pulse conditions. The ultra-low ESR (milliOhm) minimizes the instantaneous voltage drop, while the high retained capacitance reduces the charge related drop.

EFFICIENCY/TALKTIME BENEFITS OF BESTCAP™

Using a BestCap™ in parallel with a battery, provides a current pulse with a substantially higher voltage than that available from the battery alone (see Fig. 5). Thus the efficiency of the RF power amplifier is improved.

Fig. 5 GSM Pulse

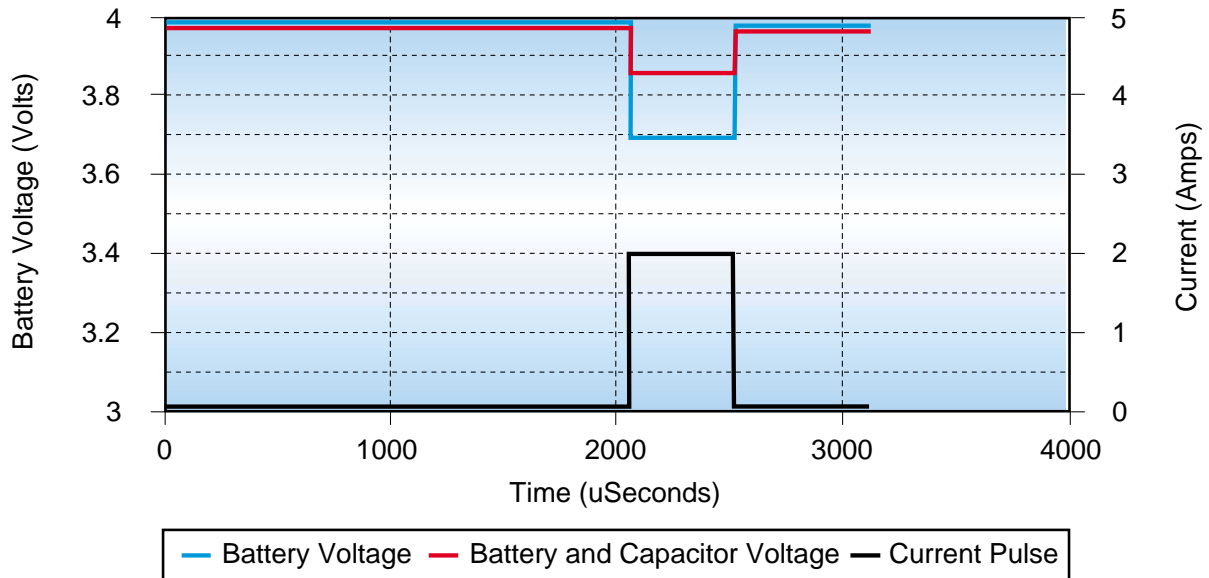

Additionally, the higher-than battery voltage supplied by the BestCap™ keeps the voltage pulse above the "cut off voltage" limit for a significantly longer time than is the case for the battery alone. This increase in "talktime" is demonstrated in figures 6a) (Li-Ion at +25°C) and 6b) (Li-Ion at 0°C).

Fig. 6a Li-ION Battery at +25°C

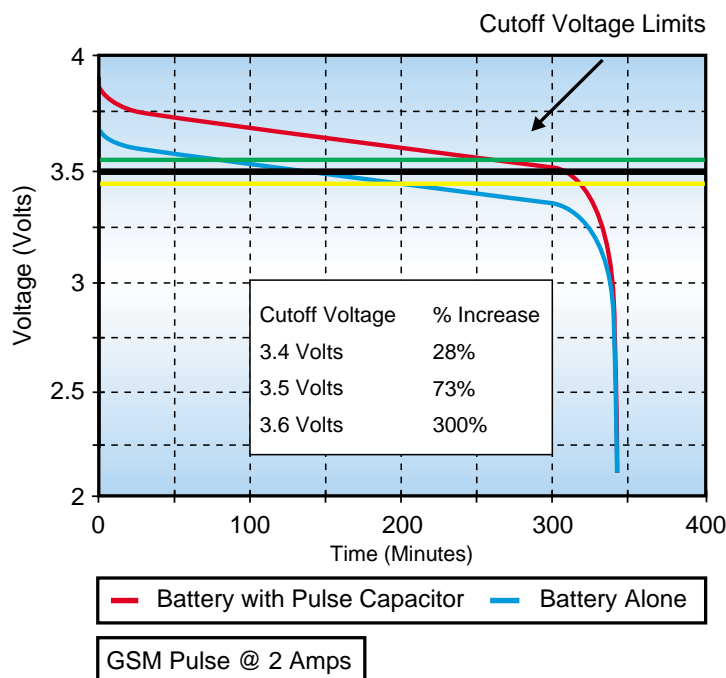
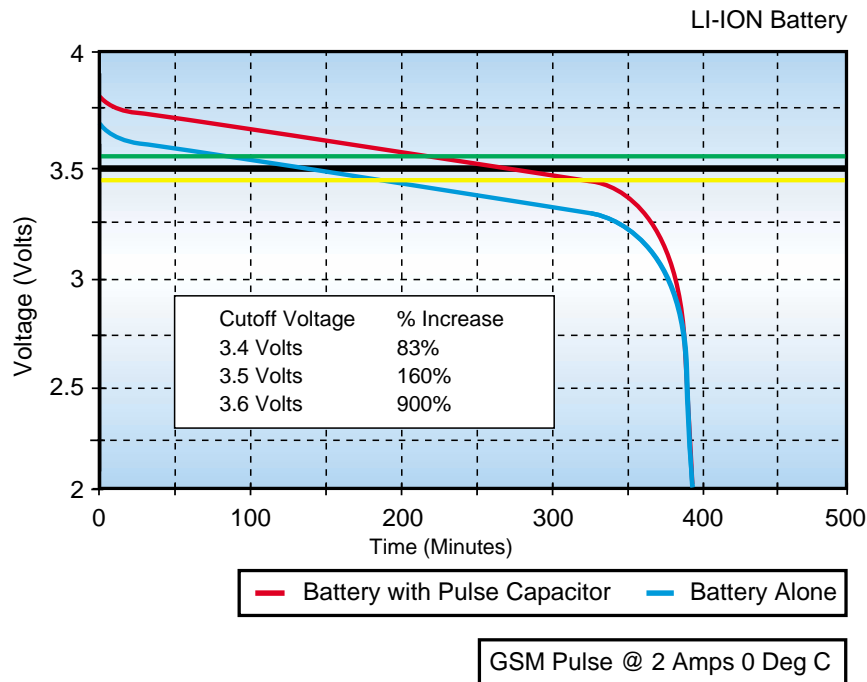

Fig. 6b Battery Life at 0°C



ENGINEERING GUIDANCE NOTES

1. Operating and storage temperature:

-20°C to +70°C. Storage at room temperature is recommended.

2. Voltage:

Rated voltage of the capacitor is per the data sheet and the label on the product. A surge voltage of +20% above rated voltage may be applied to the capacitor for <5 sec without damage or performance degradation.

3. Temperature/Voltage Recommendations

Temperature	-20°C to +40°C	+40°C to +70°C
Rated Voltage	Recommended Maximum Applied Voltage	
3.5V	3.5V	3.3V
5.5V	5.5V	5.0V
7V	7V	7V
9V	9V	8.2V
12V	12V	12V

4. Vibration and drop

Vibrations: Sine wave 10-55Hz, amplitude 0.762 mm peak, all axes *

Drop: 1.22 meters, all axes*

* For further information please contact your local AVX representative

5. Typical characteristics over temperature range:

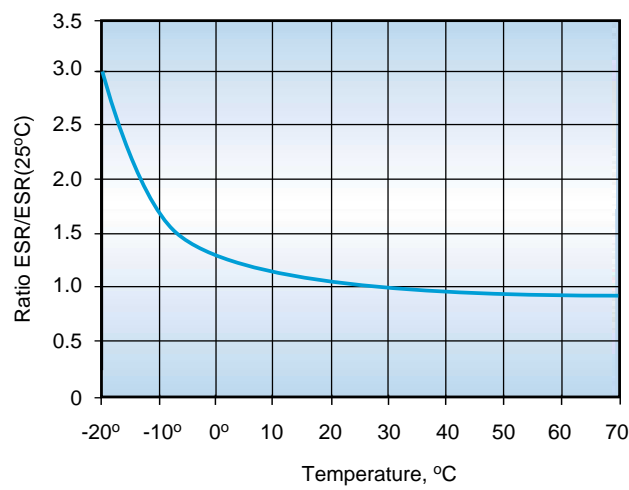
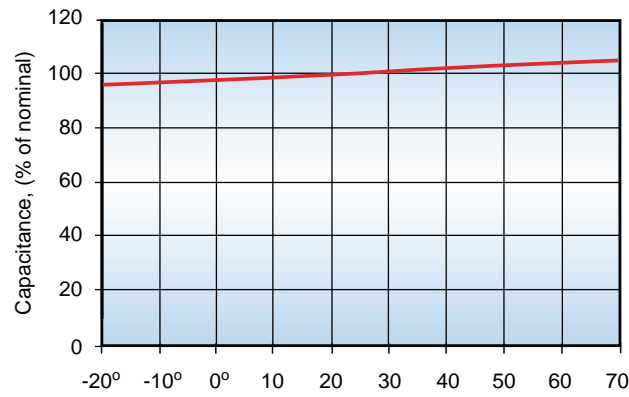

6. Impedance and ESR versus frequency

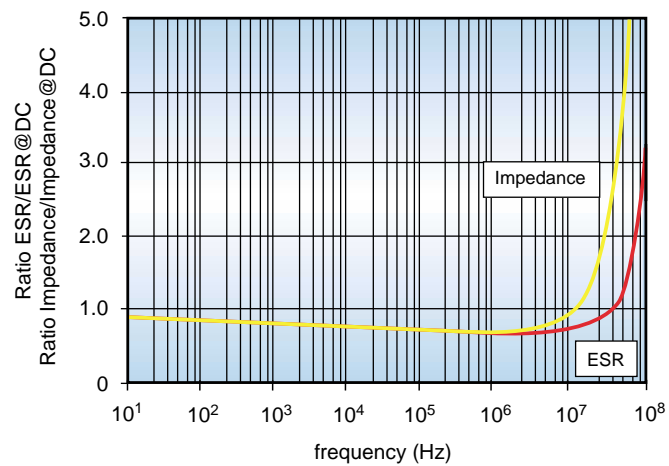

7. Polarity

BestCap™ capacitors are non-polar, and therefore can handle both positive and negative voltages.

8. Mounting

BestCap™ may not be reflow or wave soldered. Hand soldering of the device is acceptable. When hand soldering, use a soldering iron of <30W rating and ensure that the tip temperature does not exceed +350°C. Duration of the soldering operation should be <3 sec.

Other non hand soldering technics such as by pulse soldering machine may apply.

For further information please contact your local AVX representative.

9. Other Precautions

- Do not disassemble the capacitor
- Do not dispose of the capacitor by incineration.
- Should the internal material come in contact with the skin or eyes, wash/rinse thoroughly with running water.

10. Dimensions and layout design.

Part number	Thickness "T" Max	Figure
BZ013A703ZAB	2.9	1
BZ015A503ZAB	3.5	1
BZ013A144ZAB	4.7	2
BZ015A104ZAB	6.1	2
BZ013B803ZAB	3.8	2
BZ015B603ZAB	4.8	2

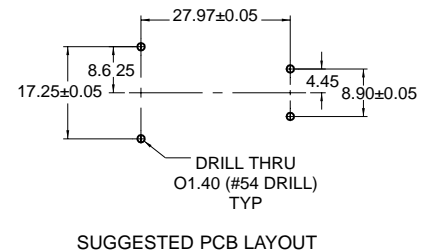
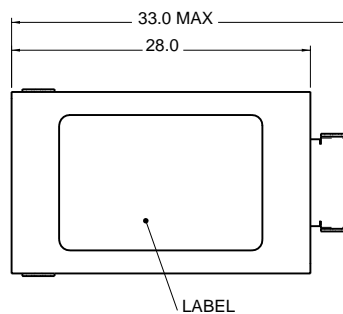

Fig. 1

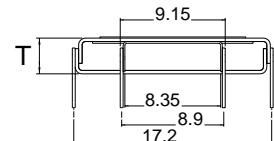
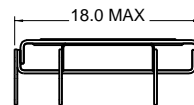
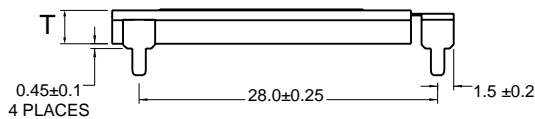
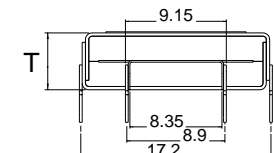
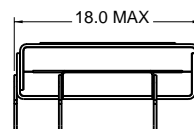
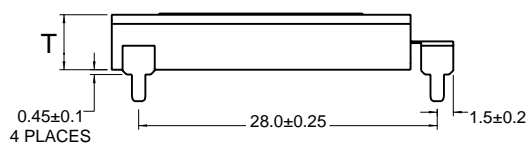
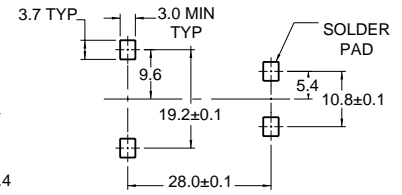
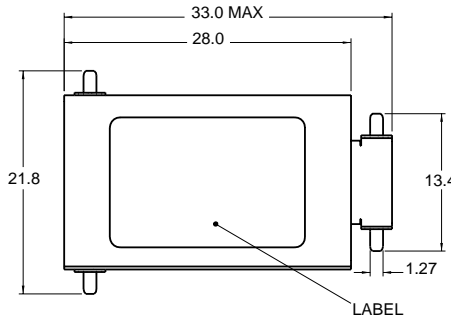

Fig. 2



Part number	Thickness "T" Max	Figure
BZ013A703ZLB	2.9	2
BZ015A503ZLB	3.5	2
BZ013A144ZLB	4.7	1
BZ015A104ZLB	6.1	1
BZ015B603ZLB	4.8	1



SUGGESTED PCB LAYOUT

Fig. 1

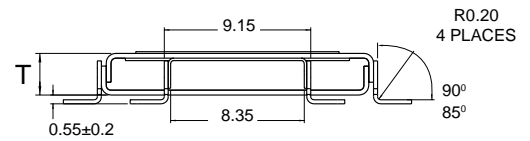
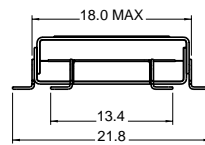
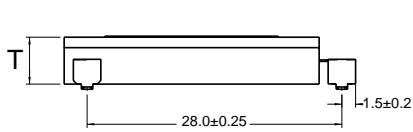
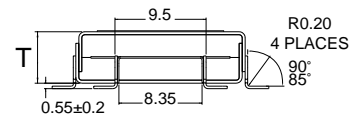
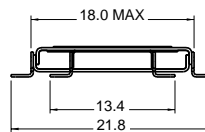
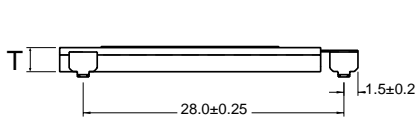
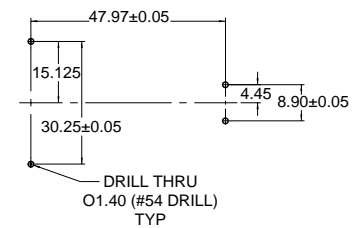
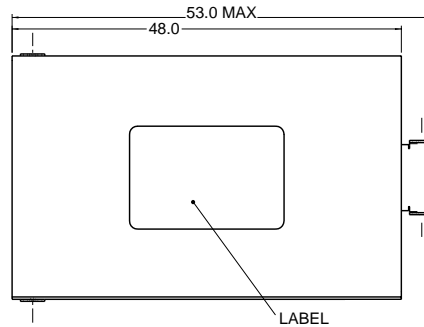

Fig. 2



Part number	Thickness "T" Max	Figure
BZ023A284ZAB	2.9	1
BZ025A204ZAB	3.5	1
BZ023A564ZAB	4.7	2
BZ025A404ZAB	6.1	2



SUGGESTED PCB LAYOUT

Fig. 1

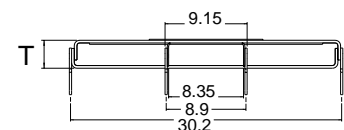
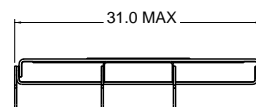
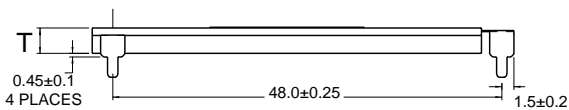
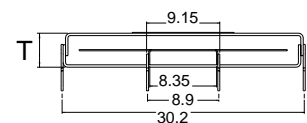
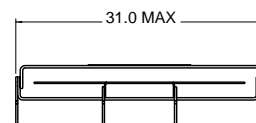
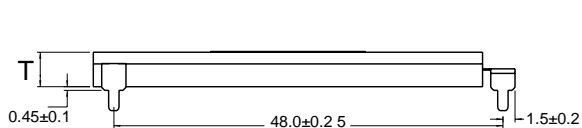

Fig. 2



Part number	Thickness "T" Max	Figure
BZ023A284ZLB	2.9	1
BZ025A204ZLB	3.5	1
BZ023A564ZLB	4.7	2
BZ025A404ZLB	6.1	2

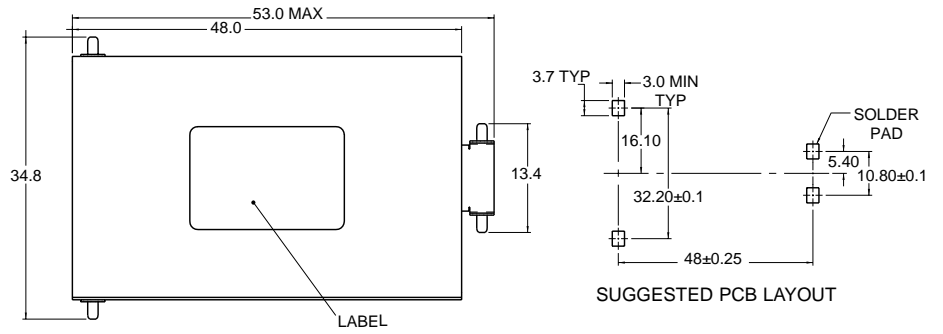

Fig. 1

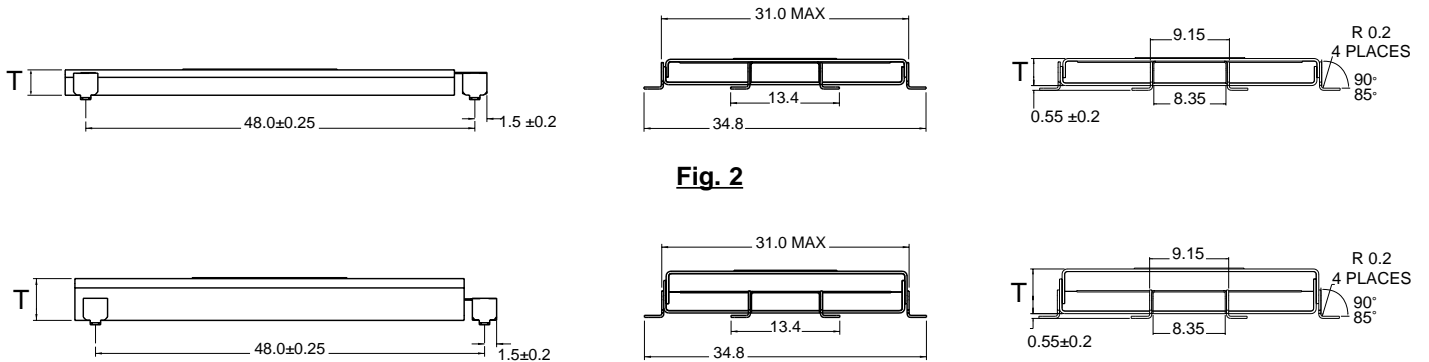
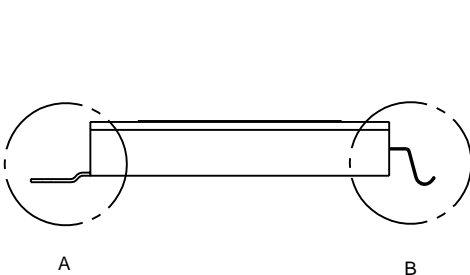
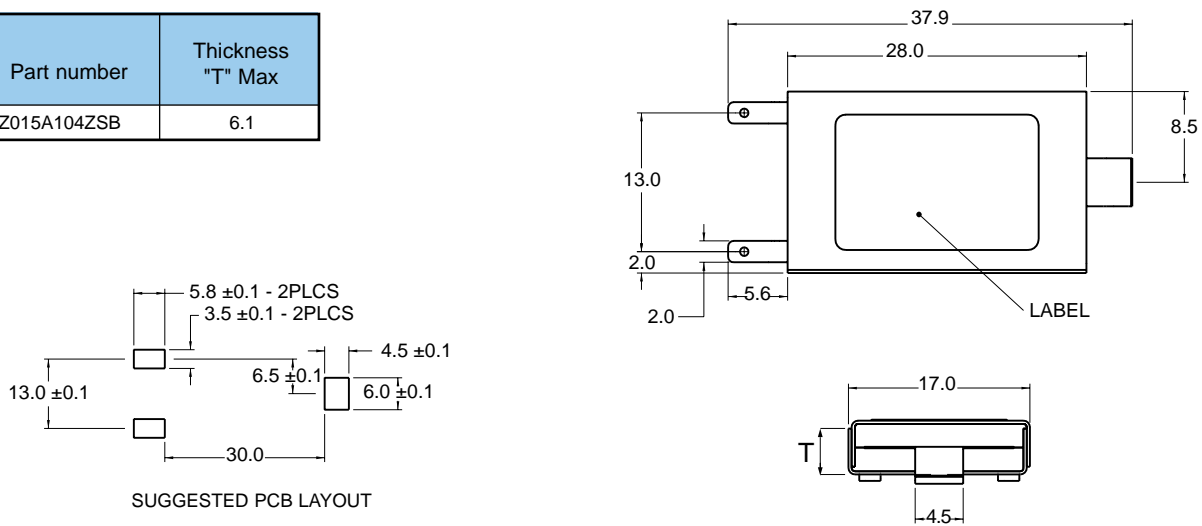

Fig. 2

Part number	Thickness "T" Max
BZ015A104ZSB	6.1



DETAIL A

DETAIL B

Part number	Thickness "T" Max
BZ015A503ZSB	3.5
BZ015A303ZSB	2.7
BZ013B403ZSB	2.1
BZ013A703ZSB	2.9
BZ017A333ZSB	4.5
BZ019A333ZSB	4.9
BZ01CA223ZSB	6.5

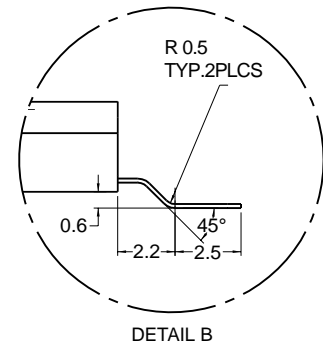
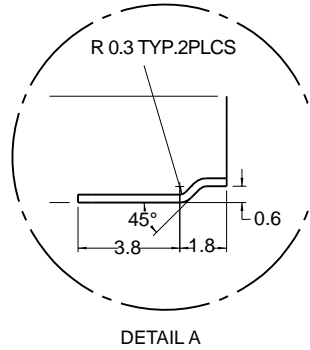
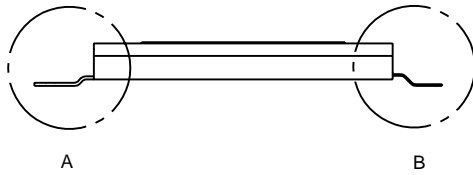
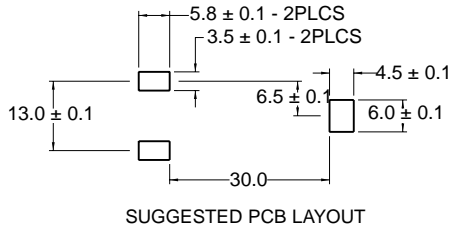
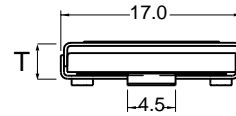
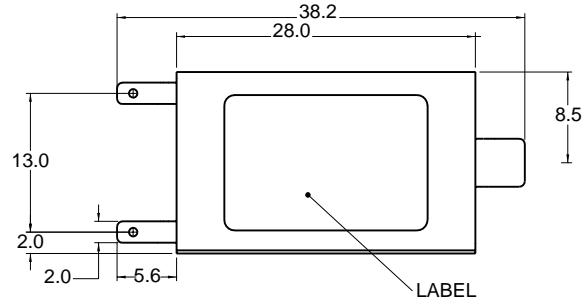

TYPICAL APPLICATIONS:

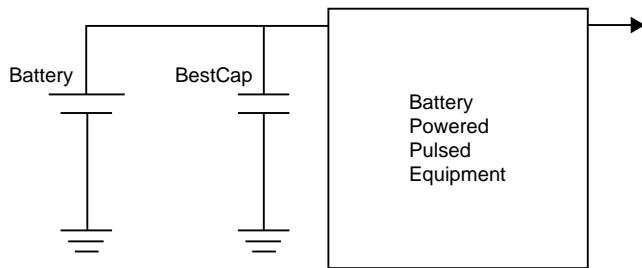

Power storage in
Automatic meter reading / Alarms

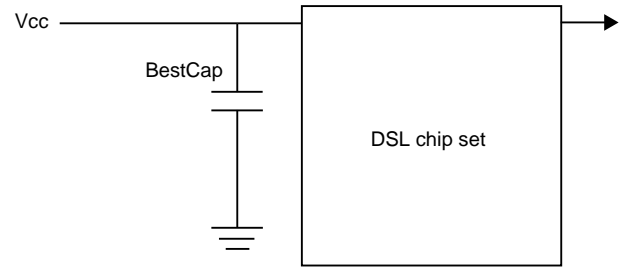

Hold up in ADSL (dying gasp)
and their Communication equipment

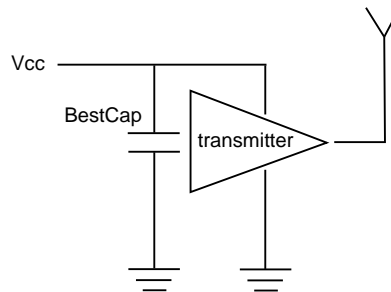

Power storage in
GSM/GPRS systems

DESIGNER KITS

Kit Number	Part number	Capacitance Milli Farad +80%-20%	Rated voltage	ESR (milli Ohms) +/-20% @1KHz	Dimensions (mm)
KITBZ040	BZ013B403ZSB	40	3.5V	140	28x17x2.1
	BZ013A703ZAB	70	3.5V	140	28x17x2.9
	BZ013B803ZAB	80	3.5V	70	28x17x3.8
	BZ013A144ZAB	140	3.5V	70	28x17x4.7
KITBZ050	BZ015B303ZSB	30	5.5V	160	28x17x2.7
	BZ015A503ZAB	50	5.5V	160	28x17x3.5
	BZ015B603ZLB	60	5.5V	80	28x17x4.8
	BZ015A104ZSB	100	5.5V	80	28x17x6.1
KITBZ060	BZ023A564ZAB	560	3.5V	25	48x30x4.7
	BZ023A284ZAB	280	3.5V	45	48x30x2.9
KITBZ070	BZ025A204ZAB	200	5.5V	60	48x30x3.5
	BZ025A404ZAB	400	5.5V	35	48x30x6.1

Kit includes 2 pieces from each part number



USA

AVX Myrtle Beach, SC
Corporate Offices
Tel: 843-448-9411
Fax: 843-448-1943

AVX Northwest, WA
Tel: 360-669-8746
Fax: 360-699-8751

AVX North Central, IN
Tel: 317-848-7153
Fax: 317-844-9314

AVX Northeast, MA
Tel: 508-485-8114
Fax: 508-485-8471

AVX Mid-Pacific, CA
Tel: 952-974-9155
Fax: 952-974-9179

AVX Southwest, AZ
Tel: 480-539-1496
Fax 480-539-1501

AVX South Central, TX
Tel: 972-669-1223
Fax: 972-669-2090

AVX Southeast, NC
Tel: 919-878-6357
Fax: 919-878-6462

AVX Canada
Tel: 905-564-8959
Fax: 905-564-9728

AVX Limited, England
European Headquarters
Tel: ++44 (0)1252 770000
Fax: ++44 (0)1252 770001

AVX S.A., France
Tel: ++33 (1) 69.18.46.00
Fax: ++33 (1) 69.28.73.87

AVX GmbH, Germany
Tel: ++49 (0) 8131 9004-0
Fax: ++49 (0) 8131 9004-44

AVX GmbH, Germany - Elco
Tel: ++49 (0) 2741 2990
Fax: ++49 (0) 2741 299299

AVX srl, Italy
Tel: ++390 (0)2 614571
Fax: ++390 (0)2 614 2576

AVX sro, Czech Republic
Tel: ++420 (0)467 558111
Fax: ++420 (0)467 523010

ASIA-PACIFIC

AVX/Kyocera, Singapore
Asia-Pacific Headquarters
Tel: (65) 258-2833
Fax: (65) 350-4880

AVX/Kyocera, Hong Kong
Tel: (852) 2-363-3303
Fax: (852) 2-765-8185

AVX/Kyocera, Korea
Tel: (82) 2-785-6504
Fax: (82) 2-784-5411

AVX/Kyocera, Taiwan
Tel: (886) 2-2696-4636
Fax: (886) 2-2696-4237

AVX/Kyocera, China
Tel: (86) 21-6249-0314-16
Fax: (86) 21-6249-0313

AVX/Kyocera, Malaysia
Tel: (60) 4-228-1190
Fax: (60) 4-228-1196

Elco, Japan
Tel: 045-943-2906/7
Fax: 045-943-2910

Kyocera, Japan - AVX
Tel: (81) 75-604-3426
Fax: (81) 75-604-3425

Kyocera, Japan - KDP
Tel: (81) 75-604-3424
Fax: (81) 75-604-3425

<http://www.avxcorp.com>