

PASSIVE AND ELECTRONIC COMPONENTS

Standard EIA Color Code Table

■ 4 BAND: ±2%, ±5%, AND ±10%

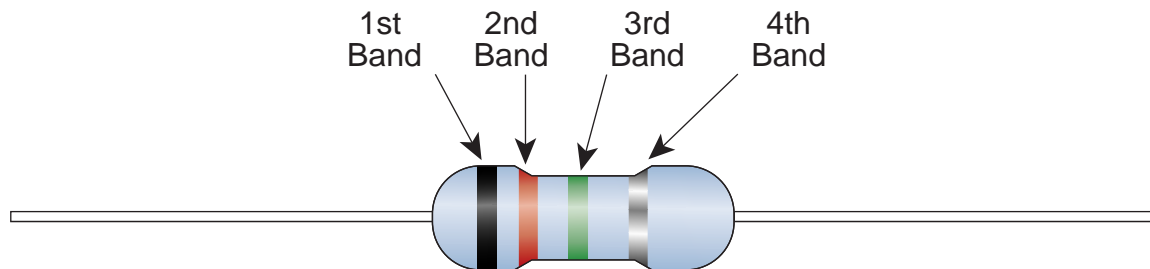

Color	1st Band (1st figure)	2nd Band (2nd figure)	3rd Band (multiplier)	4th Band (tolerance)
Black	0	0	10^0	
Brown	1	1	10^1	
Red	2	2	10^2	±2%
Orange	3	3	10^3	
Yellow	4	4	10^4	
Green	5	5	10^5	
Blue	6	6	10^6	
Violet	7	7	10^7	
Gray	8	8	10^8	
White	9	9	10^9	
Gold			10^{-1}	±5%
Silver			10^{-2}	±10%

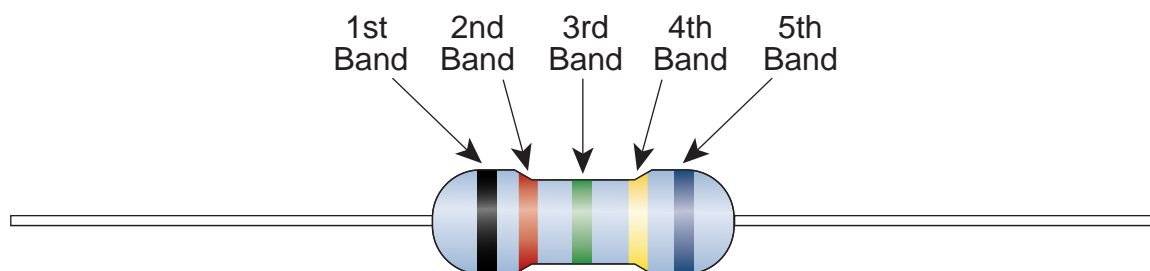

Color	1st Band (1st figure)	2nd Band (2nd figure)	3rd Band (3rd figure)	4th Band (multiplier)	5th Band (tolerance)
Black	0	0	0	10^0	
Brown	1	1	1	10^1	±1%
Red	2	2	2	10^2	
Orange	3	3	3	10^3	
Yellow	4	4	4	10^4	
Green	5	5	5	10^5	±.5%
Blue	6	6	6	10^6	±.25%
Violet	7	7	7	10^7	±.1%
Gray	8	8	8	10^8	
White	9	9	9	10^9	
Gold				10^{-1}	



Contents

Capacitors

Series	Description	Temperature Range	Voltage	Page
Electrolytic Capacitors				
- -	Electrolytic Application Notes	- - -	- - -	4
ESRL	Low ESR, 2000 hr. radial, 105°C	-55 ~ +105	6.3 ~ 100	5
XRL	Standard low, medium, and high voltage, general purpose, radial	-40 ~ +85	6.3 ~ 450	8
XAL	Standard low, medium, and high voltage, general purpose, axial	-40 ~ +85	6.3 ~ 450	11
HTRL	105° C low and medium voltage, general purpose, radial	-40 ~ +105	6.3 ~ 250	13
HTAL	105° C low and medium voltage, general purpose, axial	-40 ~ +105	6.3 ~ 100	15
LLRL	Low voltage, low leakage radial	-40 ~ +85	6.3 ~ 100	17
BPHR	Bi-Polar high frequency for horizontal deflection circuits, radial	-40 ~ +85	6.3 ~ 100	19
NPRL	Non-polar radial for audio circuits	-40 ~ +85	6.3 ~ 100	20
NPAL	Non-polar axial for audio circuits	-40 ~ +85	6.3 ~ 100	22
BPRL	Bi-polar radial for audio circuits	-40 ~ +85	6.3 ~ 100	24
L	5mm height, micro miniature radial	-40 ~ +85	2 ~ 50	25
MLRL	7mm height, sub-miniature radial	-25 ~ +85	6.3 ~ 50	27
LS	Snap in radial, 85° C low and medium voltage	-40 ~ +85	16 ~ 250	29
Film Capacitors				
- -	Film Capacitor Application Notes	- - -	- - -	31
MF	Metallized polyester film, radial general purpose	-40 ~ +85	50 ~ 630	32
23M	Metallized polyester film, axial general purpose	-40 ~ +85	100 ~ 1000	34
MEX	Metallized polyester film, boxed radial, Class X2	-40 ~ +85	250VAC	36
MEB	Metallized polyester film, boxed radial	-40 ~ +85	100 ~ 630	37
PD	Polypropylene radial capacitors	-40 ~ +85	250 ~ 630	38
MPP	Metallized polypropylene radial capacitors	-40 ~ +85	100 ~ 630	40
23P	Polystyrene capacitors	-40 ~ +85	50	42
PF	Polyester film, radial general purpose	-40 ~ +85	50 ~ 400	44
PM	Polyester film, sub-miniature radial general purpose	-40 ~ +85	100 ~ 400	46
PFN	Polyester film, non-inductive radial general purpose	-40 ~ +85	50 ~ 200	48
Ceramic Capacitors				
CA10	Small body ceramic axial, laser etched numbers	-55 ~ +125	50	49
CDR I	Ceramic disc class I	-25 ~ +85	50 ~ 500	50
CDR I HV	Ceramic disc class I high voltage	-30 ~ +85	1KV ~ 10KV	51
CDR II	Ceramic disc class II	-30 ~ +85	50 ~ 500	52
CDR II HV	Ceramic disc class II high voltage	-30 ~ +85	1KV ~ 10KV	54
CDR III	Ceramic disc class III	-30 ~ +85	12 ~ 50	56
CDR T&R	Tape and Reel specifications for ceramic disc capacitors	- - -	- - -	58
CDS	Low value AC rated ceramic disc capacitors	- - -	- - -	59
EDM	Epoxy dipped multilayer radial	-30 ~ +85	50 ~ 100	60
24AA	Ceramic trimmer	-30 ~ +85	200 ~ 400	62
242	Ceramic trimmer	-30 ~ +85	100 ~ 250	63
CC	Ceramic chip surface mount, 0603, 0805, 1206, and 1210	-55 ~ +125	50	65
- -	General Information for CD series	- - -	- - -	67
- -	Surface Mount Application Notes	- - -	- - -	68

Resistors

Series	Description	Power Range	Page
SMNR	Surface mount network resistors	1/8 Watt	69
CR1	Surface mount chip resistors, 1% tolerance, 0805 and 1206	1/10, 1/8 Watt	70
CR5	Surface mount chip resistors, 5% tolerance, 0603, 0805, and 1206	1/16, 1/10, 1/8 Watt	72
Z	Zero ohm jumper resistors	1/8, 1/4 Watt	73
CF	General purpose carbon film resistors, 5% tolerance	1/8, 1/4, 1/2, 1 Watt	74
MF	General purpose metal film resistors, 1% tolerance	1/8, 1/4, 1/2 Watt	76
CF/MF T&R	Tape and reel specifications for CF and MF series resistors	- - -	78
CC	General purpose carbon composition resistors, 5% tolerance	1/4, 1/2, 1 Watt	79
CC T&R	Tape and reel specifications for CC series resistors	- - -	81
MO	General purpose metal oxide film resistors, 5% tolerance	1, 2, 3, 5 Watt	82
SIP	Single inline package network resistors, 6, 8, and 10 pin	1/8 Watt per resistor	84
PRM	Cement power resistors, vertical radial mount, 5% tolerance	5, 7, 10 Watt	85
PRS	Cement power resistors, Vertical mount, 5% tolerance	15 Watt	86
PW	Cement power resistors, axial mount, 5% tolerance	5, 10, 15, 25 Watt	87
PZ	Cement power resistors, 5% tolerance	5, 10, 15, 25 Watt	89
HS	Xicon/Arcol aluminum housed power resistors	10 ~ 600 Watt	91
NHS	Non-inductive aluminum housed power resistors for dummy load apps	100, 200, 300 Watt	93

Varistors and Potentiometers

Series	Description	Page
VL	Zinc oxide varistors, 5mm, 7mm, 10mm, 14mm and 20mm	94
FR	Trimmer Potentiometers	99
LU	Trimmer Potentiometers	100

Fastron Inductors

Series	Description	Page
Inductors	Fastron Inductors	101



It is very important to select an aluminum electrolytic capacitor that will perform in accordance with good engineering design practices.

1. Polarity:

Electrolytic capacitors have polarity and should be used for DC applications. If used in reversed polarity, the circuit life may be reduced. For usage on circuits whose polarity is occasionally reversed or whose polarity is unknown, use nonpolar capacitors.

2. Operating Voltage:

Do not apply a voltage exceeding the capacitor's rating. Otherwise the capacitor may be damaged and leakage current may increase.

3. Ripple Current:

The ripple current on the capacitor should be at or below rated level.

4. Operating Temperature:

Although the capacitor will operate at a slightly higher or lower temperature than specified with a small derating curve, do not exceed the specified operating temperature range for an extended period of time. Usage at room temperature will ensure long life.

5. Leakage Current:

The leakage current shall be within specified levels. When the capacitor is operated at a lower voltage, the actual leakage current will be reduced proportionately.

6. Surge Voltage:

The surge voltage rating is the maximum DC over-voltage to which the capacitor may be subjected to, for short periods not exceeding approximately 30 seconds at frequent intervals of not more than five minutes. Unless otherwise specified, the rated surge voltage of the electrolytic capacitors are as follows:

Working Voltage (WV)	6.3	10	16	25	35	40	50	63	100	160	200	250	350	400	450
Surge Voltage (SV)	8	13	20	32	44	50	63	79	125	200	250	300	400	450	500

7. Soldering:

(A) It is important to be careful of temperature and time when soldering. Dip or flow soldering of the capacitors should be limited to less than 260°C and 10 seconds.

(B) High levels of humidity will affect the solderability of lead wire and terminals. High temperatures will reduce long term operating life.

(C) Use of defective soldering techniques affect the inside characteristics, such as increasing leakage current, short circuit, broken or damaged lead wires, and leaking electrolyte.

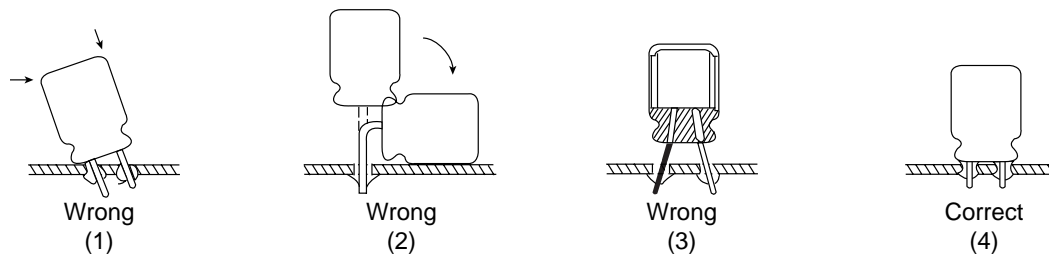

- (1) Parts slant to the board after soldering.
- (2) Leads are greatly bent after soldering.
- (3) Lead space on board differs from the original.
- (4) Flush with the board and leads straight.

Additional Instructions:

- 1. If the capacitors are stored or left unused for a long period, they should be subjected to a low voltage and brought up to the rated working voltage for 30 to 60 min. before application to reduce the leakage current to the initial value.
- 2. The electrolytic capacitor is not suitable for circuits in which charge and discharge are frequently repeated, otherwise the capacitance value may drop, or the capacitor may be damaged.
- 3. Do not apply excessive force to the lead wires or terminals, or they may be broken or their connections with the internal elements may be affected.
- 4. Capacitors will be affected by some solvents. Alcohol based solvents are recommended, or water with a mild detergent. Some solvents not recommended are trichloroethylene (TCE), acetone, or any halogenous solvents.



FEATURES

- Very low ESR
- High permissible ripple current
- Wide operating temperature range
- Long life and high reliability
- Suited for switching power supplies
- Satisfies characteristic W of JIS-C-5141 standard



CHARACTERISTICS

Item	Characteristics									
Operating Temperature Range	-55°C ~ +105°C									
Capacitance Tolerance	±20% at +20°C, 120Hz									
Leakage Current	I = 0.01CWV or 3μA whichever is greater after 2 minutes of applied rated DC working voltage at 20°C Where: C = rated capacitance in μF; WV = rated DC working voltage									
Dissipation Factor (Tan δ, at +20°C 120Hz)	Working voltage (WV)	6.3	10	16	25	35	50	63	100	
	Tan δ	0.22	0.19	0.16	0.14	0.12	0.10	0.08	0.07	
For capacitors whose capacitance exceeds 1,000μF, the specification of tan δ is increased by 0.02 for every addition of 1,000μF.										
Surge Voltage	Working voltage (WV)	6.3	10	16	25	35	50	63	100	
	Surge voltage (SV)	8	13	20	32	44	63	79	125	
Low Temperature Characteristics	Working voltage (WV)	6.3	10	16	25	35	50	63	100	
	Impedance ratio, Z-55°C/Z-20°C	3	2	2	2	2	2	2	2	2
Life Test	When returned to +20°C after 2,000 hours application of working voltage at +105°C, the capacitor will meet the following limits: Capacitance change is ±20% of initial value; tan δ is < 200% of initial specified value; leakage current is ≤ initial specified value									
Shelf Test	When returned to +20°C after 1,000 hours +105°C with no voltage applied, the capacitor will meet the following limits: Capacitance change is ±20% of initial value; tan δ is < 200% of initial specified value; leakage current is ≤ initial specified value									

PART NUMBERING SYSTEM

E	S	R	L		5	0	V		1	0	0
Series					Voltage Actual Value				Capacitance (μF) Actual Value		

RIPPLE CURRENT AND FREQUENCY MULTIPLIERS

Working Voltage (WV)	Frequency (Hz)				
	60 (50)	120	500	1K	≥10K
6.3 ~ 16	0.55	0.70	0.85	0.95	1.00
25 ~ 35	0.45	0.60	0.75	0.90	1.00
50 ~ 100	0.40	0.55	0.70	0.85	1.00

RIPPLE CURRENT AND TEMPERATURE MULTIPLIERS

Temperature (°C)	<50	70	85	105
Multiplier	2.40	2.05	1.7	1.0



■ RIPPLE CURRENT (mA RMS @105°C,120Hz)

Value (µF)	Working Voltage (WV)							
	6.3	10	16	25	35	50	63	100
1						12	NA	13
2.2						18	NA	21
3.3						22	NA	27
4.7						27	NA	34
6.8						33	NA	41
10						39	43	52
22					47	65	69	122
33			51	49	64	80	93	166
39			65	55	72	105	100	193
47		73	67	64	82	115	165	252
56		68	76	73	92	190	195	274
68		63	81	84	105	250	225	326
100	74	82	100	110	200	250	350	475
220	120	140	215	205	350	530	585	854
330	160	225	300	355	495	680	750	1160
390	225	265	350	465	565	760	965	1340
470	280	295	380	495	670	815	1130	1410
560	300	350	470	590	695	1040	1180	1680
680	355	395	515	700	820	1110	1440	1910
1000	495	555	770	850	1080	1520	1720	
1200	545	735	745	1240	1250	1680		
2200	845	905	1140	1240	1790	2080		
3300	915	1180	1330	1760	2080			
4700	1230	1580	1760	2060				

■ RIPPLE CURRENT (mA RMS @105°C,100KHz)

Value (µF)	Working Voltage (WV)											
	6.3	10	16	25	35	50	63	100				
1							24	NA	27			
2.2							36	NA	43			
3.3							44	NA	54			
4.7							54	NA	68			
6.8							61	NA	83			
10							78	86	104			
22						89	122	129	230			
33						98	98	114	141	164	293	
39						100	96	125	153	176	337	
47						98	110	108	137	176	279	423
56						100	125	120	151	191	325	456
68						101	130	134	170	306	358	526
100	110	124	155	169	301	376	527	719				
220	166	193	296	269	477	726	798	1170				
330	212	296	395	464	645	866	979	1520				
390	292	346	452	597	726	979	1240	1730				
470	352	372	477	620	842	1020	1420	1770				
560	372	431	577	726	855	1280	1450	2070				
680	431	477	620	842	986	1340	1730	2300				
1000	577	645	894	986	1260	1760	1990					
1200	620	836	850	1030	1430	1920						
2200	942	1010	1270	1380	1990	2320						
3300	1020	1320	1480	1960	2320							
4700	1370	1760	1960	2290								

■ MAXIMUM ESR (Ω @ -10°C,100KHz)

Value (µF)	Working Voltage (WV)							
	6.3	10	16	25	35	50	63	100
1						55.00	NA	46.00
2.2						25.00	NA	18.00
3.3						17.00	NA	11.00
4.7						12.00	NA	7.60
6.8						8.00	NA	5.10
10						5.50	4.00	3.20
22					3.80	2.50	2.00	1.50
33			5.50	4.00	2.50	1.60	1.30	1.10
39			4.80	3.30	2.10	1.40	1.10	0.97
47		5.50	4.40	2.80	1.70	1.10	0.93	0.76
56		4.80	3.40	2.20	1.40	0.95	0.85	0.65
68		4.00	2.50	1.80	1.20	0.78	0.70	0.57
100	4.30	2.80	1.80	1.20	0.80	0.43	0.45	0.46
220	1.50	1.20	0.83	0.86	0.45	0.28	0.24	0.25
330	1.00	0.86	0.58	0.48	0.30	0.22	0.18	0.17
390	0.85	0.75	0.55	0.35	0.28	0.18	0.18	0.14
470	0.73	0.65	0.45	0.33	0.23	0.17	0.16	0.15
560	0.65	0.67	0.38	0.28	0.21	0.17	0.15	0.11
680	0.57	0.45	0.36	0.23	0.18	0.15	0.12	0.097
1000	0.38	0.30	0.28	0.18	0.17	0.12	0.10	
1200	0.36	0.30	0.22	0.16	0.16	0.11		
2200	0.25	0.19	0.19	0.15	0.10	0.088		
3300	0.17	0.16	0.14	0.10	0.088			
4700	0.16	0.14	0.12	0.90				

■ MAXIMUM ESR (Ω @ 20°C,100KHz)

Value (µF)	Working Voltage (WV)									
	6.3	10	16	25	35	50	63	100		
1						22.00	NA	17.00		
2.2						10.00	NA	6.60		
3.3						6.70	NA	4.10		
4.7						4.70	NA	2.80		
6.8						3.20	NA	1.90		
10						2.20	1.60	1.20		
22						1.50	0.98	0.78	0.55	
33				2.10	1.60	0.99	0.65	0.52	0.42	
39				1.90	1.30	0.83	0.55	0.45	0.36	
47				2.10	1.60	1.10	0.69	0.45	0.37	0.28
56				1.90	1.30	0.89	0.57	0.38	0.34	0.24
68				1.60	1.00	0.72	0.48	0.31	0.28	0.21
100	1.70	1.10	0.70	0.49	0.32	0.17	0.18	0.17		
220	0.61	0.48	0.33	0.33	0.18	0.11	0.094	0.093		
330	0.40	0.33	0.23	0.19	0.12	0.081	0.073	0.062		
390	0.34	0.30	0.21	0.14	0.11	0.073	0.070	0.053		
470	0.29	0.26	0.18	0.13	0.093	0.066	0.063	0.056		
560	0.26	0.22	0.15	0.11	0.082	0.066	0.058	0.041		
680	0.22	0.18	0.14	0.093	0.072	0.060	0.048	0.036		
1000	0.15	0.12	0.11	0.072	0.068	0.046	0.044			
1200	0.14	0.12	0.086	0.065	0.062	0.043				
2200	0.099	0.073	0.073	0.063	0.040	0.035				
3300	0.068	0.062	0.055	0.041	0.035					
4700	0.065	0.054	0.046	0.036						



■ DIMENSIONS

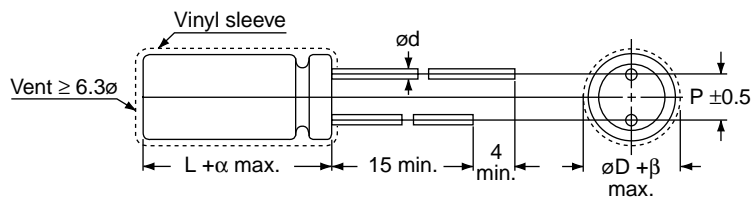

Lead Spacing and Diameter (mm)

øD	5	6.3	8	10	13	16	18
P	2.0	2.5	3.5	5.0	5.0	7.5	7.5
ød	0.6	0.6	0.6	0.6	0.6	0.8	0.8
β	0.6	0.5	0.5	0.5	0.5	1.0	1.0
α	1.0 for L ≤ 16; 2.0 for L ≥ 20						

Value (µF)	Working Voltage (WV); Dimensions: øD x L (mm)							
	6.3	10	16	25	35	50	63	100
1						5 x 11	5 x 11	5 x 11
2.2						5 x 11	5 x 11	5 x 11
3.3						5 x 11	5 x 11	5 x 11
4.7						5 x 11	5 x 11	6.3 x 11
6.8						5 x 11	6.3 x 11	6 x 11
10						5 x 11	6.3 x 11	8 x 11.5
22					5 x 11	6.3 x 11	6.3 x 11	8 x 11.5
33			5 x 11	5 x 11	6.3 x 11	6.3 x 11	8 x 11.5	10 x 12.5
39			5 x 11	6.3 x 11	6.3 x 11	6.3 x 11	8 x 11.5	10 x 16
47		5 x 11	6.3 x 11	6.3 x 11	6.3 x 11	6.3 x 11	8 x 11.5	10 x 20
56		5 x 11	6.3 x 11	6.3 x 11	6.3 x 11	8 x 11.5	10 x 12.5	10 x 20
68		5 x 11	6.3 x 11	6.3 x 11	6.3 x 11	8 x 11.5	10 x 12.5	10 x 25
100	5 x 11	6.3 x 11	6.3 x 11	8 x 11.5	8 x 11.5	10 x 16	10 x 20	13 x 20
220	6.3 x 11	8 x 11.5	8 x 11.5	10 x 12.5	10 x 16	10 x 25	13 x 20	16 x 25
330	8 x 11.5	8 x 11.5	10 x 12.5	10 x 16	10 x 20	13 x 20	13 x 25	16 x 31.5
390	8 x 11.5	10 x 12.5	10 x 16	10 x 20	10 x 25	13 x 25	16 x 20	16 x 35.5
470	10 x 12.5	10 x 12.5	10 x 16	10 x 20	13 x 20	13 x 26	16 x 25	18 x 35.5
560	10 x 12.5	10 x 16	10 x 20	10 x 25	13 x 20	16 x 20	16 x 31.5	18 x 35.5
680	10 x 16	10 x 16	10 x 20	13 x 20	13 x 25	16 x 20	16 x 31.5	18 x 40
1000	10 x 20	10 x 20	13 x 20	13 x 26	16 x 20	16 x 31.5	18 x 35.5	
1200	10 x 20	10 x 25	13 x 20	13 x 25	16 x 25	16 x 35.5		
2200	13 x 20	13 x 25	13 x 26	16 x 25	16 x 35.5	18 x 40		
3300	13 x 25	16 x 20	16 x 31.5	16 x 35.5	18 x 40			
4700	16 x 25	16 x 31.5	16 x 35.5	18 x 40				



FEATURES

- Low impedance characteristics
- Case sizes are smaller than conventional general-purpose capacitors, with very high performance
- Can size larger than 9mm diameter has safety vents on rubber end seal



CHARACTERISTICS

Item	Characteristics													
Operating Temperature Range	6.3WV ~ 100WV is -40°C ~ +85°C; 160WV ~ 450WV is -25°C ~ +85°C													
Capacitance Tolerance	±20% at 20°C, 120Hz													
Leakage Current	≤100V	I = 0.02C _{WV} or 3μA whichever is greater after 2 minutes of applied rated DC working voltage at 20°C Where: C = rated capacitance in μF; WV = rated DC working voltage												
	>100V	I = 0.02C _{WV} + 25(μA) after 5 minutes of applied rated DC working voltage at 20°C Where: C = rated capacitance in μF; WV = rated DC working voltage												
Dissipation Factor (Tan δ, at 20°C 120Hz)	Working voltage (WV)	6.3	10	16	25	35	50	63	100	160	250	350	450	
	Tan δ	0.23	0.20	0.17	0.15	0.12	0.10	0.09	0.08	0.12	0.17	0.20	0.25	
For capacitors whose capacitance exceeds 1,000μF, the specification of tan δ is increased by 0.02 for every addition of 1,000μF														
Surge Voltage	Working voltage (WV)	6.3	10	16	25	35	50	63	100	160	250	350	450	
	Surge voltage (SV)	8	13	20	32	44	63	79	125	200	300	400	500	
Low Temperature Characteristics (Imp. ratio @ 120Hz)	Working voltage (WV)	6.3	10	16	25	35	50	63	100	160	250	350	450	
	Z-25°C/+20°C	∅D<16	6	4	3	3	2	2	2	2	3	6	8	14
		∅D≥16	8	6	4	4	3	3	3	3	3	6	8	14
	Z-40°C/+20°C	∅D<16	10	8	6	6	4	3	3	3	4	8	10	-
∅D≥16		18	16	12	10	8	8	6	6	4	8	10	-	
Life Test	When returned to +20°C after 2,000 hours application of working voltage at +85°C, the capacitor will meet the following limits: Capacitance change is ≤ ±20% of initial value; tan δ is < 200% of specified value; leakage current is within specified value													
Shelf Life Test	When returned to +20°C after 1,000 hours at +85°C with no voltage applied, the capacitor will meet the following limits: Capacitance change is ≤ ±20% of initial value; tan δ is < 200% of specified value; leakage current is within specified value for 6.3~100V and less than 200% of specified value for 160V~450V													

PART NUMBERING SYSTEM

X	R	L	1	6	V	1	0	0
Series			Voltage Actual Value			Capacitance (μF) Actual Value		

RIPPLE CURRENT AND FREQUENCY MULTIPLIERS

Capacitance (μF)	Frequency (Hz)				
	60 (50)	120	500	1K	≥10K
<100	0.70	1.0	1.30	1.40	1.50
100 ~ 1000	0.75	1.0	1.20	1.30	1.35
>1000	0.80	1.0	1.10	1.12	1.15

RIPPLE CURRENT AND TEMPERATURE MULTIPLIERS

Temperature (°C)	<50	70	85
Multiplier (6.3WV ~ 100WV)	1.78	1.4	1.0
Multiplier (160WV ~ 450WV)	2.20	1.6	1.0



■ DIMENSIONS AND PERMISSIBLE RIPPLE CURRENT

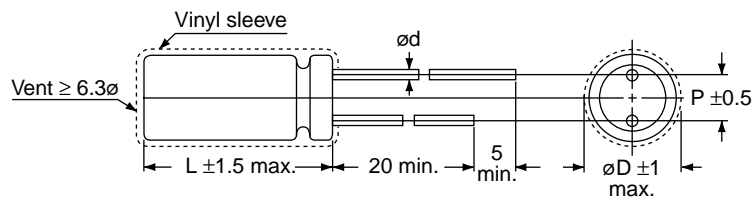

Lead Spacing and Diameter (mm)

ϕD	5	6.3	8	10	13	16	18	22	25
P	2.0	2.5	3.5	5.0	5.0	7.5	7.5	10	12.5
ϕd	0.5	0.5	0.5	0.6	0.6	0.8	0.8	1.0	1.0

Value (μF)	Working Voltage (WV); Dimensions: $\phi D \times L$ (mm); Ripple Current: mA/RMS @ 120Hz, 85°C													
	10		16		25		35		50		63		100	
	$\phi D \times L$	mA	$\phi D \times L$	mA	$\phi D \times L$	mA	$\phi D \times L$	mA	$\phi D \times L$	mA	$\phi D \times L$	mA	$\phi D \times L$	mA
.10									5 x 11	1.5	5 x 11	3.0	5 x 11	3.0
.22									5 x 11	3.5	5 x 11	4.5	5 x 11	5
.33									5 x 11	5.0	5 x 11	7.5	5 x 11	8
.47					5 x 11	6.0			5 x 11	6.5	5 x 11	9.5	5 x 11	10
1.0					5 x 11	10			5 x 11	15	5 x 11	17	5 x 11	20
2.2			5 x 11	20					5 x 11	25	5 x 11	28	5 x 11	31
3.3			5 x 11	30					5 x 11	30	5 x 11	34	5 x 11	38
4.7			5 x 11	41					5 x 11	41	5 x 11	44	5 x 11	47
10	5 x 11	54	5 x 11	54			5 x 11	56	5 x 11	60	5 x 11	63	6.3 x 11	75
22	5 x 11	75	5 x 11	75	5 x 11	80	5 x 11	85	6.3 x 11	94	6.3 x 11	105	8 x 11.5	130
33	5 x 11	86	5 x 11	87	5 x 11	94	6.3 x 11	106	6.3 x 11	136	8 x 11.5	150	10 x 16	195
47	5 x 11	96	5 x 11	106	5 x 11	113	6.3 x 11	126	8 x 11.5	165	8 x 11.5	180	10 x 16	248
100	5 x 11	134	6.3 x 11	160	6.3 x 11	190	8 x 11.5	215	8 x 11	260	10 x 13	300	10 x 20	365
220	6.3 x 11	240	8 x 11.5	277	8 x 11.5	320	10 x 12	381	10 x 16	455	10 x 20	479	13 x 21	675
330	8 x 11.5	310	8 x 11.5	350	10 x 16	450	10 x 20	510	13 x 21	635	13 x 26	700	16 x 32	972
470	8 x 11.5	362	10 x 12.5	485	10 x 16	536	10 x 20	620	13 x 21	760	16 x 27	920	16 x 32	1135
1000	10 x 13.5	630	10 x 16	740	13 x 21	1058	13 x 21	1115	16 x 27	1350	16 x 32	1630	22 x 41	2600
2200	13 x 21	1100	13 x 21	1260	16 x 27	1500	16 x 32	1871	18 x 41	2231	22 x 41	2100		
3300	13 x 26	1395	16 x 27	1720	16 x 32	1900	18 x 37	2446	22 x 41	2300	25 x 50	2560		
4700	16 x 27	1800	16 x 32	2000	18 x 37	2400	18 x 36	2750	25 x 41	3300	25 x 50	3510		
6800	16 x 36	1950	16 x 32	2200	22 x 41	2600	22 x 41	2900						
10000	18 x 41	2655	18 x 36	3000	25 x 41	3420								

Value (μF)	Working Voltage (WV); Dimensions: $\phi D \times L$ (mm); Ripple Current: mA/RMS @ 120Hz, 85°C							
	160		250		350		450	
	$\phi D \times L$	mA	$\phi D \times L$	mA	$\phi D \times L$	mA	$\phi D \times L$	mA
.47	5 x 11	10	8 x 11.5	12	8 x 11.5	15	10 x 12.5	17
1.0	5 x 11	14	8 x 11.5	16	8 x 11.5	21	10 x 12.5	25
2.2	6.3 x 11	23	8 x 11.5	32	10 x 16	42	10 x 16	42
3.3	8 x 11.5	33	10 x 12.5	46	10 x 16	52	10 x 20	57
4.7	8 x 11.5	39	10 x 16	62	10 x 20	68	13 x 21	71
10	10 x 16	75	10 x 20	99	13 x 21	105	13 x 26	116
22	13 x 21	146	13 x 26	172	13 x 26	172	16 x 32	212
33	13 x 21	179	13 x 26	211	16 x 32	259	18 x 36	292
47	13 x 26	235	16 x 26	283	18 x 36	348	22 x 41	413
100	16 x 26	386	16 x 36	539	22 x 41	602	25 x 50	706
220	18 x 36	795	22 x 41	894				
330	22 x 41	1095						



■ TYPICAL PERFORMANCE CHARACTERISTICS

----- 1000 μ F 16V
 _____ 1 μ F 50V

Life Test

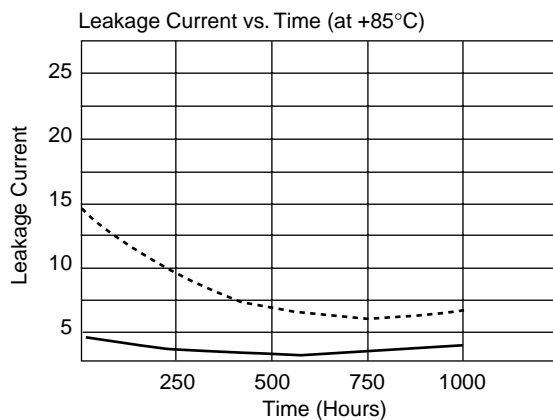
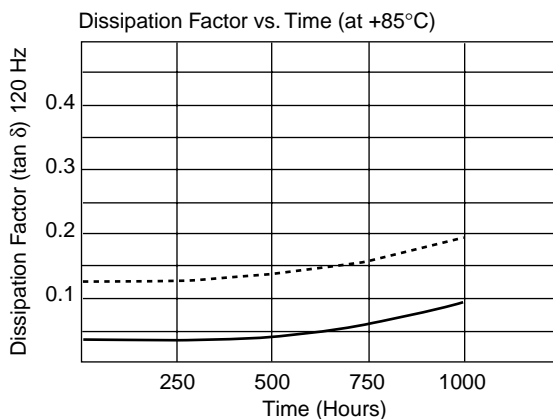
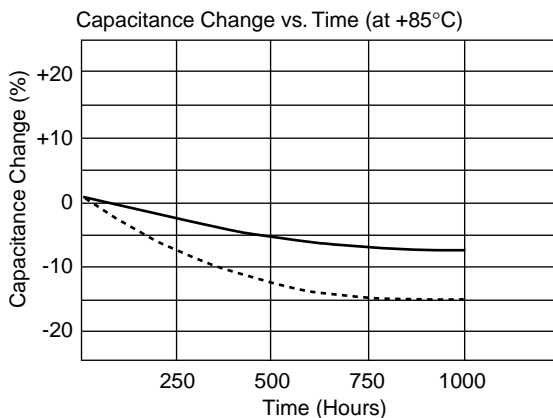

Temperature Characteristics

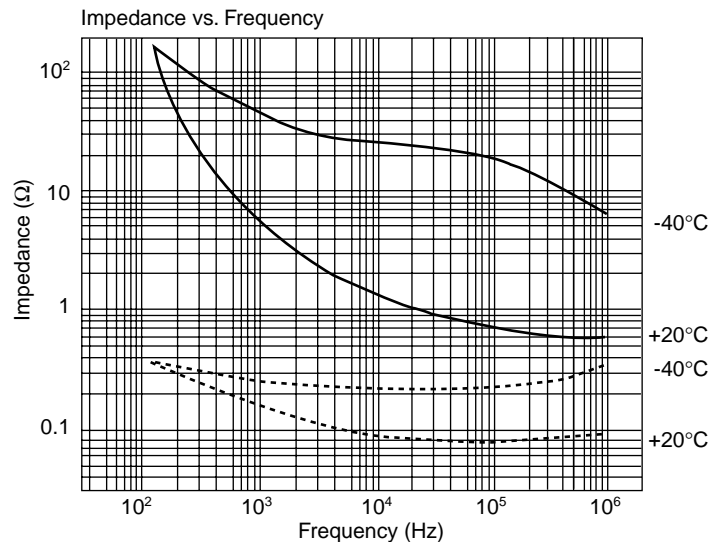
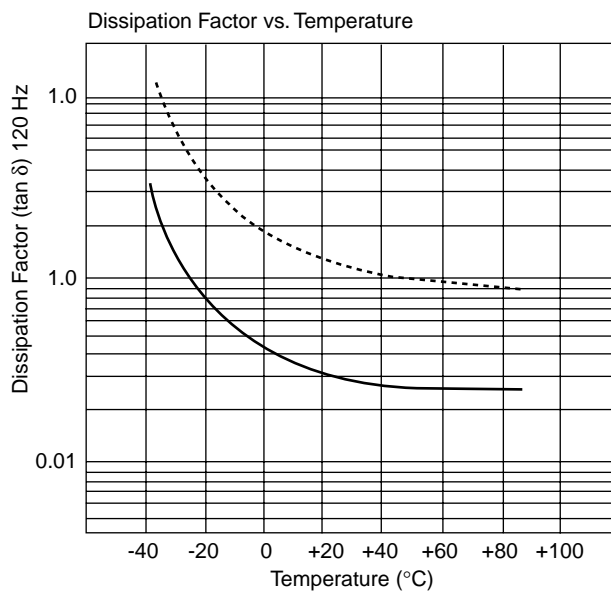
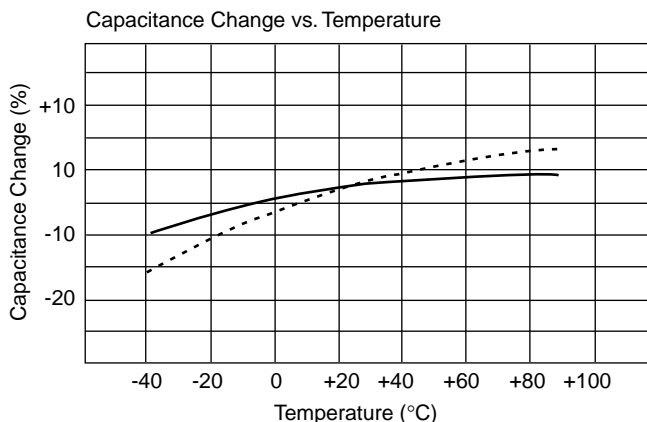



FEATURES

- Standard low, medium, and high voltage capacitors
- Low impedance characteristics
- Case sizes are smaller than conventional general purpose capacitors, with very high performance

CHARACTERISTICS

Item	Characteristics														
Operating Temperature Range	6.3WV ~ 100WV is -40°C ~ +85°C; 160WV ~ 450WV is -25°C ~ +85°C														
Capacitance Tolerance	±20% at 20°C, 120Hz														
Leakage Current	≤100V	I = 0.02C _{WV} or 3μA whichever is greater after 2 minutes of applied rated DC working voltage at 20°C Where: C = rated capacitance in μF; WV = rated DC working voltage													
	>100V	I = 0.02C _{WV} + 25(μA) after 5 minutes of applied rated DC working voltage at 20°C Where: C = rated capacitance in μF; WV = rated DC working voltage													
Dissipation Factor (Tan δ, at 20°C 120Hz)	Working voltage (WV)	6.3	10	16	25	35	50	63	100	160	200	250	350	450	
	Tan δ	0.23	0.20	0.17	0.15	0.12	0.10	0.09	0.08	0.12	0.14	0.17	0.20	0.25	
For capacitors whose capacitance exceeds 1,000μF, the specification of tan δ is increased by 0.02 for every addition of 1,000μF															
Surge Voltage	Working voltage (WV)	6.3	10	16	25	35	50	63	100	160	200	250	350	450	
	Surge voltage (SV)	8	13	20	32	44	63	79	125	200	250	300	400	500	
Low Temperature Characteristics (Imp. ratio @ 120Hz)	Working voltage (WV)	6.3	10	16	25	35	50	63	100	160	200	250	350	450	
	Z-25°C/+20°C	øD<16	6	4	3	3	2	2	2	2	3	6	8	12	16
		øD≥16	8	6	4	4	3	3	3	3	3	6	8	12	16
	Z-40°C/+20°C	øD<16	10	8	6	6	4	3	3	3	4	8	10	-	-
øD≥16		18	16	12	10	8	8	6	6	4	8	10	-	-	
Life Test	When returned to +20°C after 2,000 hours application of working voltage at +85°C, the capacitor will meet the following limits: Capacitance change is ≤ ±20% of initial value; tan δ is < 200% of specified value; leakage current is within specified value														
Shelf Life Test	When returned to +20°C after 1,000 hours at +85°C with no voltage applied, the capacitor will meet the following limits: Capacitance change is ≤ ±20% of initial value; tan δ is < 200% of specified value; leakage current is within specified value for 6.3~100V and less than 200% of specified value for 160V~450V														
Standards	Satisfies Characteristic W of JIS C5141														

PART NUMBERING SYSTEM

X	A	L	5	0	V	1	0	0
Series			Voltage Actual Value			Capacitance (μF) Actual Value		

RIPPLE CURRENT AND FREQUENCY MULTIPLIERS

Capacitance (μF)	Frequency (Hz)				
	60 (50)	120	500	1K	≥10K
<100	0.70	1.0	1.3	1.4	1.5
100 ~ 1000	0.75	1.0	1.2	1.3	1.35
>1000	0.80	1.0	1.1	1.12	1.15

RIPPLE CURRENT AND TEMPERATURE MULTIPLIERS

Temperature (°C)	<50	70	85
Multiplier	1.78	1.40	1.0



■ DIMENSIONS AND PERMISSIBLE RIPPLE CURRENT

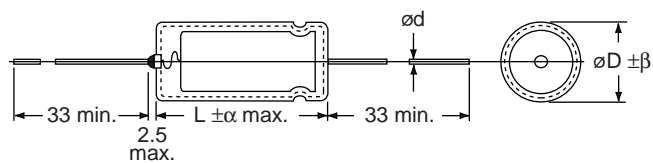

Lead Spacing and Diameter (mm)

øD	5	6.3	8	10	13	16	18	22	25
ød	0.6	0.6	0.6	0.6	0.8	0.8	0.8	1.0	1.0
α	1.5	1.5	1.5	1.5	2.0	2.0	2.0	2.0	2.0
β	0.5	0.5	0.5	0.5	1.0	1.0	1.0	1.0	1.0

Value (µF)	Working Voltage; Dimensions: øD x L (mm); Ripple Current: mA/RMS @ 120Hz, 85°C															
	6.3		10		16		25		35		50		63		100	
	øD x L	mA	øD x L	mA	øD x L	mA	øD x L	mA	øD x L	mA	øD x L	mA	øD x L	mA	øD x L	mA
0.1											5 x 12	1.5	5 x 12	3.0	5 x 12	3.0
0.22											5 x 12	3.5	5 x 12	4.5	5 x 12	4.5
0.33											5 x 12	5.0	5 x 12	7.5	5 x 12	7.5
0.47											5 x 12	6.0	5 x 12	9.0	5 x 12	9.0
1											5 x 12	10	5 x 12	15	5 x 12	15
2.2											5 x 12	20	5 x 12	30	5 x 12	30
3.3											5 x 12	30	5 x 12	36	6.3 x 12	41
4.7											5 x 12	42	5 x 12	44	6.3 x 12	50
6.8													5 x 13	49		
10									5 x 12	55	6.3 x 12	65	6.3 x 12	68	6.3 x 12	72
22					5 x 12	71	5 x 12	76	6.3 x 12	88	6.3 x 12	96	6.3 x 14	109	8 x 16	133
33			5 x 12	78	5 x 12	88	6.3 x 12	100	6.3 x 14	115	6.3 x 14	126	8 x 16	154	10 x 17	190
47	5 x 12	87	5 x 12	94	6.3 x 12	111	6.3 x 12	119	6.3 x 14	138	8 x 16	174	10 x 17	214	10 x 21	237
100	6.3 x 12	136	6.3 x 12	145	6.3 x 16	174	8 x 16	215	8 x 16	232	10 x 17	298	10 x 21	326	13 x 22	377
220	6.3 x 14	215	6.3 x 16	231	8 x 16	298	8 x 16	319	10 x 17	401	10 x 21	459	13 x 22	527	16 x 28	625
330	8 x 16	305	8 x 16	327	8 x 16	365	10 x 17	454	10 x 21	514	13 x 22	613	13 x 27	675	16 x 33	793
470	8 x 16	364	8 x 16	390	8 x 20	460	10 x 17	542	10 x 21	613	13 x 22	731	13 x 27	780	16 x 37	942
1000	10 x 17	617	10 x 17	662	10 x 21	775	13 x 22	873	13 x 27	955	16 x 33	1111	18 x 38	1249	22 x 43	1359
2200	13 x 26	929	13 x 22	1051	13 x 22	1125	16 x 28	1344	16 x 33	1421	18 x 42	1699	22 x 43	1744		
3300	13 x 22	1150	13 x 27	1288	16 x 28	1454	16 x 33	1611	16 x 37	1640	22 x 43	2027	25 x 52	2309		
4700	13 x 27	1354	16 x 28	1552	16 x 33	1650	18 x 38	1811	22 x 43	2206	25 x 52	2347				
10000	16 x 37	2062	18 x 42	2122	22 x 43	2503	22 x 52	2893								
22000	22 x 43	3097														

Value (µF)	Working Voltage; Dimensions: øD x L (mm); Ripple Current: mA/RMS @ 120Hz, 85°C									
	160		200		250		350		450	
	øD x L	mA	øD x L	mA	øD x L	mA	øD x L	mA	øD x L	mA
1	6.3 x 12	7	6.3 x 16	9	6.3 x 16	12	8 x 16	13	8 x 16	15
2.2	6.3 x 12	15	8 x 16	16	8 x 16	17	8 x 20	19	10 x 21	23
3.3	8 x 16	21	8 x 16	26	8 x 20	31	8 x 20	33	10 x 21	36
4.7	8 x 16	31	8 x 16	33	10 x 17	38	10 x 21	44	13 x 22	46
10	10 x 17	60	10 x 21	66	10 x 21	72	13 x 22	77	13 x 27	82
22	13 x 22	121	13 x 22	121	13 x 27	126	13 x 27	132	16 x 37	143
33	13 x 22	154	13 x 27	167	16 x 28	178	16 x 33	186	16 x 42	201
47	13 x 27	198	16 x 32	214	16 x 33	241	18 x 42	253	22 x 43	402
100	16 x 33	345	16 x 37	368	18 x 43	391	18 x 40	402	25 x 52	448
220	18 x 42	586	22 x 43	609	22 x 43	632				
330	22 x 43	632								



FEATURES

- Excellent temperature performance
- 105°C high operating temperature
- Satisfies characteristic W of JIS-C-5141 standard

CHARACTERISTICS

Item		Characteristics											
Operating Temperature Range		-40°C ~ +105°C											
Capacitance Tolerance		±20% at 20°C, 120Hz											
Leakage Current	6.3WV ~ 100WV	I = 0.01CWV or 3μA whichever is greater after 2 minutes of applied rated DC working voltage at 20°C Where: C = rated capacitance in μF; WV = rated DC working voltage											
	160WV ~ 250WV	For CWV ≤ 1,000: I = 0.03CWV +15μA, for CWV > 1,000: I = 0.02CWV +25μA after 5 min. of applied rated DC working voltage at 20°C. Where: C = rated capacitance in μF; WV = rated DC working voltage											
Dissipation Factor (Tan δ, at 20°C 120Hz)	Working voltage (WV)	6.3	10	16	25	35	50	63	100	160	250		
	Tan δ	0.23	0.20	0.16	0.14	0.12	0.10	0.09	0.08	0.20	0.20		
For capacitors whose capacitance exceeds 1,000μF, the specification of tan δ is increased by 0.02 for every addition of 1,000μF													
Surge Voltage	Working voltage (WV)	6.3	10	16	25	35	50	63	100	160	250		
	Surge voltage (SV)	8	13	20	32	44	63	79	125	200	300		
Low Temperature Characteristics	Working voltage (WV)	6.3	10	16	25	35	50	63	100	160	250		
	Impedance ratio @ 120Hz	Z-25°C/Z+20°C	∅D < 16	4	3	3	2	2	2	2	2	3	3
			∅D ≥ 16	6	4	4	3	3	3	3	3	3	3
		Z-40°C/Z+20°C	∅D < 16	8	6	6	4	4	3	3	3	4	4
∅D ≥ 16			12	10	8	8	8	8	8	6	6	4	4
Life Test	When returned to +20°C after 1,000 hours application of working voltage at +105°C, the capacitor will meet the following limits: Capacitance change is ≤ ±20% of initial value; tan δ is < 200% of initial specified value; leakage current is ≤ initial specified value												
Shelf Life Test	When returned to +20°C after 1,000 hours at +105°C with no voltage applied, the capacitor will meet the following limits: Capacitance change is ≤ ±20% of initial value; tan δ is < 200% of initial specified value; leakage current is ≤ initial specified value												

PART NUMBERING SYSTEM

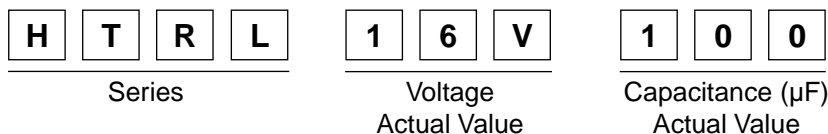

RIPPLE CURRENT AND FREQUENCY MULTIPLIERS

6.3WV ~100WV Capacitance (μF)	Frequency (Hz)				
	60	120	500	1K	≥10K
<100	0.70	1.0	1.30	1.40	1.50
100 ~ 1000	0.75	1.0	1.20	1.30	1.35
>1000	0.80	1.0	1.10	1.12	1.15

Working Voltage (All Capacitances)	Frequency (Hz)					
	60 (50)	120	500	1K	10K	≥20K
160WV ~ 250WV	0.80	1.0	1.10	1.10	1.30	1.35

RIPPLE CURRENT AND TEMPERATURE MULTIPLIERS

Temperature (°C)	45	70	85	105
Multiplier (6.3WV ~ 100WV)	1.95	1.78	1.40	1.00
Multiplier (160WV ~ 250WV)	2.05	1.45	1.00	1.00



■ DIMENSIONS AND PERMISSIBLE RIPPLE CURRENT

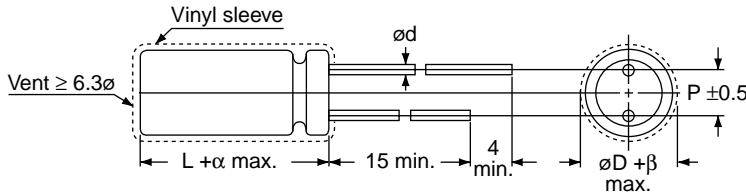

Lead Spacing and Diameter (mm)

ϕD	5	6.3	8	10	13	16	18	22
P	2.0	2.5	3.5	5.0	5.0	7.5	7.5	7.5
ϕd	0.5	0.5	0.5	0.6	0.6	0.8	0.8	1.0
β	0.5	0.5	0.5	0.5	0.5	1.0	1.0	1.0
α	1.0 if $L \leq 16$; 2.0 if $L \geq 20$							

Value (μF)	Working Voltage; Dimensions: $\phi D \times L$ (mm); Ripple Current: mA/RMS @ 120Hz, 105°C									
	6.3		10		16		25		35	
	$\phi D \times L$	mA	$\phi D \times L$	mA	$\phi D \times L$	mA	$\phi D \times L$	mA	$\phi D \times L$	mA
10							5 x 11	45	5 x 11	45
22					5 x 11	58	5 x 11	62	5 x 11	71
33					5 x 11	71	5 x 11	76	6.3 x 11	88
47			5 x 11	76	5 x 11	85	5 x 11	97	6.3 x 11	105
100	5 x 11	103	5 x 11	111	6.3 x 11	133	6.3 x 11	142	8 x 11.5	166
220	6.3 x 11	158	6.3 x 11	170	8 x 11.5	214	8 x 11.5	236	10 x 12.5	290
330	8 x 11.5	219	8 x 11.5	234	8 x 11.5	271	10 x 12.5	328	10 x 20	387
470	8 x 11.5	261	8 x 11.5	289	10 x 12.5	367	10 x 20	427	13 x 21	485
1000	10 x 12.5	431	10 x 16	480	10 x 20	562	13 x 21	656	13 x 26	715
2200	10 x 20	733	13 x 21	786	13 x 26	919	16 x 26	1016	16 x 32	1138
3300	13 x 21	897	13 x 21	1006	16 x 26	1164	16 x 32	1290	18 x 36	1440
4700	16 x 26	1159	16 x 26	1243	16 x 36	1432	18 x 41	1629	22 x 41	1859

Value (μF)	Working Voltage; Dimensions: $\phi D \times L$ (mm); Ripple Current: mA/RMS @ 120Hz, 105°C									
	50		63		100		160		250	
	$\phi D \times L$	mA	$\phi D \times L$	mA	$\phi D \times L$	mA	$\phi D \times L$	mA	$\phi D \times L$	mA
0.1	5 x 11	2.0	5 x 11	3.0	5 x 11	3.0				
0.22	5 x 11	3.5	5 x 11	4.5	5 x 11	4.5				
0.33	5 x 11	5.0	5 x 11	7.5	5 x 11	7.5				
0.47	5 x 11	6.0	5 x 11	9.0	5 x 11	9.0				
1	5 x 11	10	5 x 11	15	5 x 11	15	5 x 11	10	6.3 x 11	13
2.2	5 x 11	20	5 x 11	30	5 x 11	30	6.3 x 11	15	6.3 x 11	22
3.3	5 x 11	30	5 x 11	31	5 x 11	31	6.3 x 11	27	8 x 11.5	31
4.7	5 x 11	33	5 x 11	36	6.3 x 11	40	6.3 x 11	32	8 x 11.5	37
10	5 x 11	50	5 x 11	52	8 x 11.5	66	10 x 12.5	65	10 x 16	73
22	6.3 x 11	78	8 x 11.5	93	8 x 11.5	99	10 x 20	118	13 x 21	140
33	6.3 x 11	96	8 x 11.5	114	10 x 16	148	10 x 20	145	13 x 26	188
47	8 x 11.5	130	8 x 11.5	141	10 x 16	170	13 x 21	205	16 x 21	231
100	8 x 11.5	188	10 x 16	234	13 x 21	284	16 x 21	337	16 x 36	426
220	10 x 20	345	13 x 21	397	16 x 26	455	16 x 36	632		
330	13 x 21	445	13 x 26	491	16 x 32	578	18 x 36	826		
470	13 x 26	556	16 x 26	627	18 x 37	711				
1000	16 x 32	869	16 x 36	942	22 x 41	1085				
2200	18 x 41	1319	22 x 41	1469						
3300	22 x 41	1707								

FEATURES

- Excellent temperature performance
- 105°C high operating temperature
- Suitable for industrial equipment
- Satisfies characteristic W of JIS-C-5141 standard



CHARACTERISTICS

Item	Characteristics										
Operating Temperature Range	-40°C ~ +105°C										
Capacitance Tolerance	±20% at 20°C, 120Hz										
Leakage Current	I = 0.01CWV or 3μA whichever is greater after 2 minutes of applied rated DC working voltage at 20°C Where: C = rated capacitance in μF; WV = rated DC working voltage										
Dissipation Factor (Tan δ, at 20°C 120Hz)	Working voltage (WV)	6.3	10	16	25	35	50	63	100		
	Tan δ	0.23	0.20	0.16	0.14	0.12	0.10	0.09	0.08		
For capacitors whose capacitance exceeds 1,000μF, the specification of tan δ is increased by 0.02 for every addition of 1,000μF											
Surge Voltage	Working voltage (WV)	6.3	10	16	25	35	50	63	100		
	Surge voltage (SV)	8	13	20	32	44	63	79	125		
Low Temperature Characteristics	Working voltage (WV)	6.3	10	16	25	35	50	63	100		
	Impedance ratio @ 120Hz	Z-25°C/Z+20°C	∅D < 16	4	3	3	2	2	2	2	2
			∅D ≥ 16	6	4	4	3	3	3	3	3
		Z-40°C/Z+20°C	∅D < 16	8	6	6	4	4	3	3	3
∅D ≥ 16			12	10	8	8	8	8	8	6	6
Life Test	When returned to +20°C after 1,000 hours application of working voltage at +105°C, the capacitor will meet the following limits: Capacitance change is ≤ ±20% of initial value; tan δ is < 200% of initial specified value; leakage current is ≤ initial specified value										
Shelf Life Test	When returned to +20°C after 1,000 hours at +105°C with no voltage applied, the capacitor will meet the following limits: Capacitance change is ≤ ±20% of initial value; tan δ is < 200% of initial specified value; leakage current is ≤ initial specified value										

PART NUMBERING SYSTEM

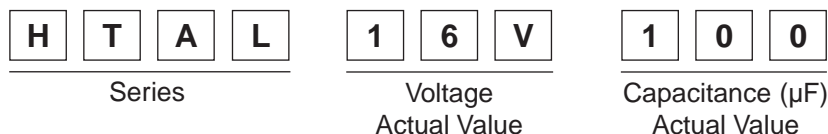

RIPPLE CURRENT AND FREQUENCY MULTIPLIERS

Capacitance (μF)	Frequency (Hz)				
	60	120	500	1K	≥10K
<100	0.70	1.0	1.30	1.40	1.50
100 ~ 1000	0.75	1.0	1.20	1.30	1.35
>1000	0.80	1.0	1.10	1.12	1.15

RIPPLE CURRENT AND TEMPERATURE MULTIPLIERS

Temperature (°C)	45	70	85	105
Multiplier	2.20	1.95	1.70	1.00



■ DIMENSIONS AND PERMISSIBLE RIPPLE CURRENT

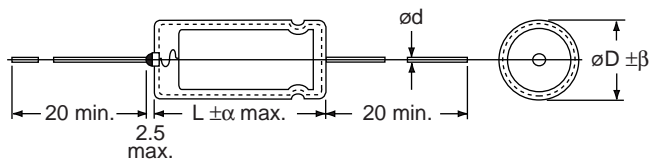

Lead Spacing and Diameter (mm)

øD	5	6.3	8	10	13	16	18	22	25
ød	0.6	0.6	0.6	0.6	0.8	0.8	0.8	1.0	1.0
α	1.5	1.5	1.5	1.5	2.0	2.0	2.0	2.0	2.0
β	0.5	0.5	0.5	0.5	1.0	1.0	1.0	1.0	1.0

Value (µF)	Working Voltage; Dimensions: øD x L (mm); Ripple Current: mA/RMS @ 120Hz, 105°C															
	6.3		10		16		25		35		50		63		100	
	øD x L	mA	øD x L	mA	øD x L	mA	øD x L	mA	øD x L	mA	øD x L	mA	øD x L	mA	øD x L	mA
0.1											5 x 12	2.0	5 x 12	3.0	5 x 12	3.0
0.22											5 x 12	3.5	5 x 12	4.5	5 x 12	4.5
0.33											5 x 12	5.0	5 x 12	7.5	5 x 12	7.5
0.47											5 x 12	6.0	5 x 12	9.0	5 x 12	9.0
1											5 x 12	10	5 x 12	15	5 x 12	15
2.2											5 x 12	20	5 x 12	30	5 x 12	30
3.3											5 x 12	38	5 x 12	32	6.3 x 12	32
4.7											5 x 12	34	5 x 12	36	6.3 x 12	34
10											5 x 12	50	6.3 x 12	56	6.3 x 16	64
22							5 x 12	63	6.3 x 12	73	6.3 x 12	80	6.3 x 16	90	8 x 16	106
33					5 x 12	73	5 x 12	78	6.3 x 16	96	6.3 x 16	105	8 x 16	123	10 x 17	150
47			5 x 12	77	6.3 x 12	93	6.3 x 12	99	6.3 x 16	114	8 x 16	140	8 x 16	162	10 x 21	180
100	6.3 x 12	113	6.3 x 12	121	6.3 x 16	145	8 x 16	166	8 x 16	180	10 x 17	225	10 x 21	248	13 x 22	287
220	6.3 x 16	172	6.3 x 16	185	8 x 16	231	8 x 16	246	10 x 17	305	10 x 21	349	13 x 22	420	13 x 27	458
330	8 x 16	236	8 x 16	253	10 x 17	323	10 x 17	345	10 x 21	391	13 x 22	450	13 x 27	495	13 x 36	582
470	8 x 16	281	8 x 16	302	10 x 17	386	10 x 21	432	13 x 22	490	13 x 27	561	13 x 27	632	16 x 32	713
1000	10 x 17	453	10 x 17	486	10 x 21	569	13 x 22	662	13 x 27	721	16 x 33	875	18 x 37	984	18 x 40	1096
2200	13 x 22	740	13 x 22	793	13 x 27	923	16 x 27	1024	16 x 37	1177	18 x 40	1408				
3300	13 x 22	906	13 x 27	1015	16 x 27	1173	16 x 33	1300	16 x 40	1449	22 x 43	1724				
4700	13 x 27	1168	16 x 27	1252	16 x 37	1442	18 x 42	1638	22 x 43	1878						

FEATURES

- Excellent low leakage current performance
- High ripple current
- Especially useful for time constant circuits
- Satisfies characteristic W of JIS-C-5141 standard

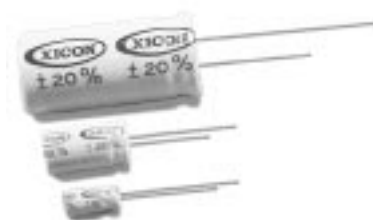

CHARACTERISTICS

Item	Characteristics									
Operating Temperature Range	-40°C ~ +85°C									
Capacitance Tolerance	±20% at 20°C, 120Hz									
Leakage Current	I = 0.002CWV or 0.4μA whichever is greater after 2 minutes of applied rated DC working voltage at 20°C Where: C = rated capacitance in μF; WV = rated DC working voltage									
Dissipation Factor (Tan δ, at 20°C 120Hz)	Working voltage (WV)	6.3	10	16	25	35	50	63	100	
	Tan δ	.24	.21	.16	.14	.12	.10	.09	.08	
	For capacitors whose capacitance exceeds 1,000μF, the specification of tan δ is increased by 0.02 for every addition of 1,000μF									
Surge Voltage	Working voltage (WV)	6.3	10	16	25	35	50	63	100	
	Surge voltage (SV)	8	13	20	32	44	63	79	125	
Low Temperature Characteristics	Working voltage (WV)	6.3	10	16	25	35	50	63	100	
	Imp. ratio @ 120Hz	Z-25°C/Z+20°C	5	4	2	2	2	2	2	2
		Z-40°C/Z+20°C	10	8	6	4	4	3	3	3
Life Test	When returned to +20°C after 1,000 hours application of working voltage at +85°C, the capacitor will meet the following limits: Capacitance change is ≤ ±20% of initial value for 6.3WV ~ 25WV and is ≤ ±15% of initial value for 35WV ~ 100WV; tan δ is < 200% of initial specified value; leakage current is initial specified value									
Shelf Life Test	When returned to +20°C after 1,000 hours at +85°C with no voltage applied, the capacitor will meet the following limits: Capacitance change is ≤ ±20% of initial value; tan δ is < 200% of initial specified value; leakage current is initial specified value									

PART NUMBERING SYSTEM

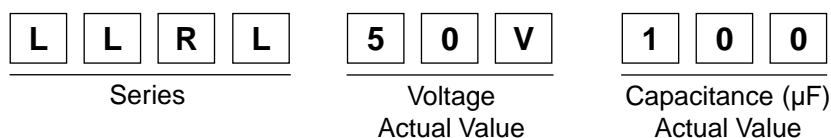

RIPPLE CURRENT AND FREQUENCY MULTIPLIERS

Capacitance (μF)	Frequency (Hz)				
	60 (50)	120	500	1K	≥10K
<100	0.75	1.0	1.35	1.55	2.00
100 ~ 1000	0.70	1.0	1.23	1.32	1.50
>1000	0.90	1.0	1.12	1.10	1.15

RIPPLE CURRENT AND TEMPERATURE MULTIPLIERS

Temperature (°C)	<50	70	85
Multiplier	1.75	1.58	1.0



■ DIMENSIONS AND PERMISSIBLE RIPPLE CURRENT

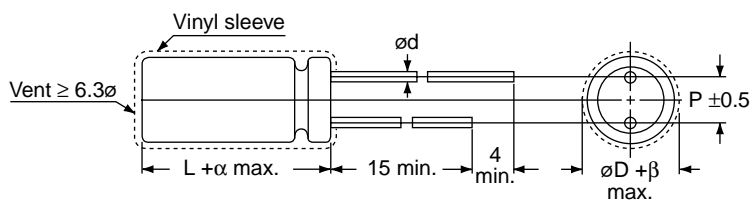

Lead Spacing and Diameter (mm)

ϕD	5	6.3	8	10	13	16	18	22
P	2.0	2.5	3.5	5.0	5.0	7.5	7.5	10
ϕd	0.5	0.5	0.5	0.6	0.6	0.8	0.8	1.0
β	0.5	0.5	0.5	0.5	0.5	1.0	1.0	1.0
α	1.0 if $L \leq 16$; 2.0 if $L \geq 20$							

Value (μF)	Working Voltage; Dimensions: $\phi D \times L$ (mm); Ripple Current: mA/RMS @ 120Hz, 105°C															
	6.3		10		16		25		35		50		63		100	
	$\phi D \times L$	mA	$\phi D \times L$	mA	$\phi D \times L$	mA	$\phi D \times L$	mA	$\phi D \times L$	mA	$\phi D \times L$	mA	$\phi D \times L$	mA	$\phi D \times L$	mA
0.1											5 x 11	1.5	5 x 11	3.0	5 x 11	3.0
0.22											5 x 11	3.5	5 x 11	4.5	5 x 11	4.5
0.33											5 x 11	5.0	5 x 11	7.5	5 x 11	7.5
0.47											5 x 11	6.0	5 x 11	9.0	5 x 11	9.0
1											5 x 11	10	5 x 11	15	5 x 11	15
2.2											5 x 11	20	5 x 11	20	6.3 x 11	30
3.3											5 x 11	30	5 x 11	41	6.3 x 11	47
4.7											5 x 11	49	6.3 x 11	53	6.3 x 11	56
10					5 x 11	65	5 x 11	65	5 x 11	65	6.3 x 11	77	6.3 x 11	77	8 x 11.5	93
22					5 x 11	88	5 x 11	88	6.3 x 11	102	6.3 x 11	115	8 x 11.5	129	8 x 11.5	143
33					5 x 11	99	6.3 x 11	115	6.3 x 11	126	8 x 11.5	158	8 x 11.5	163	10 x 16	206
47	5 x 11	99	5 x 11	108	5 x 11	119	6.3 x 11	137	8 x 11.5	169	8 x 11.5	195	10 x 16	230	10 x 20	258
100	5 x 11	145	6.3 x 11	168	6.3 x 11	185	8 x 11.5	225	8 x 11.5	255	10 x 16	336	10 x 20	352	13 x 26	429
220	6.3 x 11	230	8 x 11.5	281	8 x 11.5	309	10 x 12.5	392	10 x 16	446	13 x 21	570	13 x 26	596	16 x 32	707
330	8 x 11.5	317	8 x 11.5	355	10 x 12.5	444	10 x 20	523	13 x 21	624	13 x 26	730	16 x 26	781	16 x 36	889
470	8 x 11.5	391	10 x 12.5	481	10 x 16	551	10 x 20	624	13 x 26	779	16 x 26	932	16 x 32	966	18 x 36	1103
1000	10 x 16	673	10 x 20	764	13 x 21	919	13 x 26	1038	16 x 26	1216	16 x 36	1449	18 x 41	1541		
2200	13 x 21	1140	13 x 21	1237	16 x 26	1525	16 x 32	1708	18 x 36	1996	22 x 41	2415				
3300	13 x 26	1460	13 x 26	1584	16 x 26	1868	18 x 37	2232	18 x 41	2504						
4700	16 x 26	1865	16 x 26	2023	16 x 36	2374	18 x 41	2728	22 x 41	3158						

FEATURES

- Bi-polarized, made for horizontal deflection circuit correction of video monitors
- Long life and stable temperature characteristics
- Low cost compared with film capacitors
- High permissible ripple current at high frequency
- Satisfies characteristic W of JIS-C-5141 standard

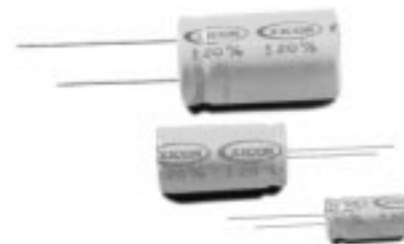

CHARACTERISTICS

Item	Characteristics	
Operating Temperature Range	-40°C ~ +85°C	
Capacitance Tolerance	±20% at +20°C, 120Hz	
Leakage Current	I = 0.2CWV after 2 minutes of applied rated DC working voltage at 20°C Where: C = rated capacitance in µF; WV = rated DC working voltage	
Dissipation Factor (Tan δ)	0.05 at +20°C, 120Hz	
Surge Voltage	Working voltage (WV)	50
	Surge Voltage (sV)	63
Low Temperature Characteristics	Capacitance at +20°C shall be within ±10% of the value at +20°C	
Life Test	When returned to +20°C after 1,000 hours application of working voltage with the polarity reversed every 250 hours at +85°C, the capacitor will meet the following limits: Capacitance change is ≤ ±15% of initial value; tan δ is < 200% of initial specified value; leakage current is ≤ initial specified value	
Shelf Test	When returned to +20°C after 500 hours +85°C with no voltage applied, the capacitor will meet the following limits: Capacitance change is ≤ ±15% of initial value; tan δ is < 200% of initial specified value; leakage current is within initial specified value	

PART NUMBERING SYSTEM

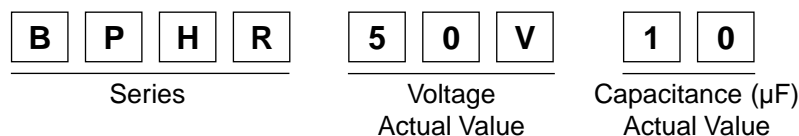

DIMENSIONS AND PERMISSIBLE RIPPLE CURRENT

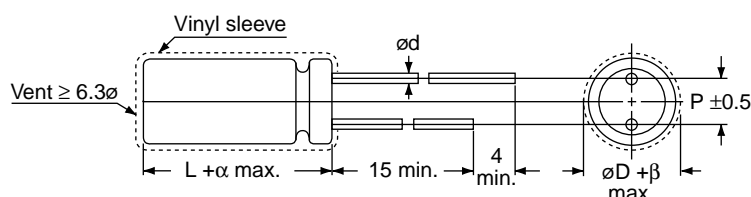

Lead Spacing and Diameter (mm)

	13	16	18	22
øD	13	16	18	22
P	5.0	7.5	7.5	10
ød	0.6	0.8	0.8	1.0
β	0.5	0.5	1.0	1.0
α	2.0	2.0	2.0	2.0

Dimensions: øD x L (mm); Ripple Current: mA/RMS @ 15.75KHz, 85°C

Working Voltage: 50WVDC									
Value	øD x L	Ap-p	Value	øD x L	Ap-p	Value	øD x L	Ap-p	
1	13 x 26	2.96	6.8	16 x 32	5.5	15	22 x 40	9	
2.2	16 x 26	3.45	8.2	16 x 36	6.37	22	22 x 40	9.5	
3.3	16 x 26	3.65	10	16 x 36	6.8	33	22 x 40	10	
4.7	16 x 32	4.54	12	18 x 40	8.5				



■ FEATURES

- Non-polarized, suitable for use in circuits whose polarity is sometimes reversed or unknown
- The leakage current and dissipation factor have been improved
- Close tolerance
- Excellent frequency characteristics in the audio range
- Satisfies characteristic W of JIS-C-5141 standard



■ CHARACTERISTICS

Item	Characteristics									
Operating Temperature Range	-40°C ~ +85°C									
Capacitance Tolerance	±10% at +20°C, 120Hz									
Leakage Current	I = 0.03CWV or 4μA whichever is greater after 2 minutes of applied rated DC working voltage at 20°C Where: C = rated capacitance in μF; WV = rated DC working voltage									
Dissipation Factor (Tan δ, at +20°C 120Hz)	Working voltage (WV)	6.3	10	16	25	35	50	63	100	
	Tan δ	0.25	0.22	0.18	0.16	0.14	0.12	0.10	0.09	
	For capacitors whose capacitance exceeds 1,000μF, the specification of tan δ is increased by 0.02 for every addition of 1,000μF.									
Surge Voltage	Working voltage (WV)	6.3	10	16	25	35	50	63	100	
	Surge voltage (SV)	8	13	20	32	44	63	79	125	
Low Temperature Characteristics	Working voltage (WV)	6.3	10	16	25	35	50	63	100	
	Impedance ratio	Z-25°C/Z+20°C	4	3	3	2	2	2	2	2
		Z-40°C/Z+20°C	8	6	6	4	4	3	3	3
Life Test	When returned to +20°C after 1,000 hours application of working voltage with the polarity inverted every 250 hours at +85°C, the capacitor will meet the following limits: Capacitance change is ≤±20% of initial value; tan δ is < 200% of initial specified value; leakage current is ≤ initial specified value									
Shelf Test	When returned to +20°C after 1,000 hours +85°C with no voltage applied, the capacitor will meet the following limits: Capacitance change is ≤±20% of initial value; tan δ is < 200% of initial specified value; leakage current is ≤ initial specified value									

■ PART NUMBERING SYSTEM

N	P	R	L
---	---	---	---

Series

5	0	V
---	---	---

Voltage
Actual Value

2	2	0
---	---	---

Capacitance (μF)
Actual Value

■ DIMENSIONS AND PERMISSIBLE RIPPLE CURRENT

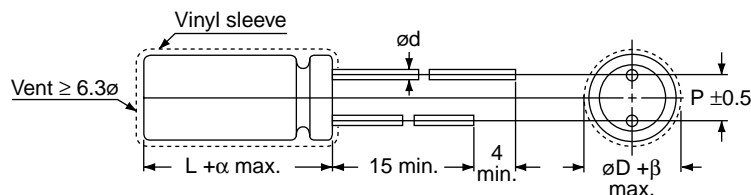

Lead Spacing and Diameter (mm)

øD	5	6.3	8	10	13	16	18
P	2.0	2.5	3.5	5.0	5.0	7.5	7.5
ød	0.5	0.5	0.5	0.6	0.6	0.8	0.8
β	0.5	0.5	0.5	0.5	0.5	1.0	1.0
α	1.0 for L ≤ 16; 2.0 for L ≥ 20						

Value (μF)	Working Voltage (WV); Dimensions: øD x L (mm); Ripple Current: mA/RMS @ 120Hz, 85°C															
	6.3		10		16		25		35		50		63		100	
	øD x L	mA	øD x L	mA	øD x L	mA	øD x L	mA	øD x L	mA	øD x L	mA	øD x L	mA	øD x L	mA
0.1											5 x 11	4	5 x 11	5	5 x 11	5
0.22											5 x 11	7	5 x 11	8	5 x 11	8
0.33											5 x 11	8	5 x 11	10	5 x 11	10
0.47											5 x 11	10	5 x 11	12	5 x 11	12
1											5 x 11	15	5 x 11	18	6.3 x 11	23
2.2											5 x 11	23	5 x 11	25	6.3 x 11	26
3.3											5 x 11	28	5 x 11	31	6.3 x 11	32
4.7											5 x 11	33	6.3 x 11	37	8 x 11.5	44
10					5 x 11	40	5 x 11	42	6.3 x 11	46	8 x 11.5	55	8 x 11.5	61	8 x 11.5	66
15											8 x 12	71				
22	5 x 11	50	5 x 11	56	5 x 11	59	6.3 x 11	63	8 x 11.5	76	8 x 11.5	82	10 x 12.5	108	10 x 16	118
33	5 x 11	62	5 x 11	69	6.3 x 11	73	6.3 x 11	78	8 x 11.5	94	8 x 11.5	104	10 x 16	137	10 x 20	152
47	5 x 11	74	6.3 x 11	83	6.3 x 11	88	8 x 11.5	105	8 x 11.5	115	10 x 16	150	10 x 20	172	13 x 21	193
100	6.3 x 11	108	8 x 11	137	8 x 11.5	149	10 x 12.5	182	10 x 16	202	10 x 20	229	13 x 21	267	16 x 26	315
220	8 x 11.5	181	10 x 12.5	242	10 x 16	265	10 x 20	294	13 x 21	335	13 x 26	378	16 x 26	443	16 x 36	498
330	8 x 15	236	10 x 16	308	10 x 20	340	13 x 21	384	13 x 26	429	16 x 26	496	16 x 32	653		
470	10 x 16	329	10 x 20	385	13 x 21	432	13 x 26	479	16 x 26	548	16 x 32	614	18 x 41	787		
1000	10 x 20	502	13 x 21	598	13 x 26	659	16 x 32	775	16 x 36	852	18 x 41	1048				
2200	13 x 26	829	16 x 26	992	16 x 36	1114	18 x 41	1347								

FEATURES

- Non-polarized, suitable for use in circuits whose polarity is sometimes reversed or unknown
- The leakage current and dissipation factor have been improved
- Close tolerance
- Excellent frequency characteristics in the audio range



CHARACTERISTICS

Item	Characteristics									
Operating Temperature Range	-40°C ~ +85°C									
Capacitance Tolerance	±10% at +20°C, 120Hz									
Leakage Current	I = 0.03CWV or 3μA whichever is greater after 2 minutes of applied rated DC working voltage at 20°C Where: C = rated capacitance in μF; WV = rated DC working voltage									
Dissipation Factor (Tan δ, at +20°C 120Hz)	Working voltage (WV)	6.3	10	16	25	35	50	63	100	
	Tan δ	0.25	0.22	0.18	0.16	0.14	0.12	0.10	0.09	
	For capacitors whose capacitance exceeds 1,000μF, the specification of tan δ is increased by 0.02 for every addition of 1,000μF.									
Surge Voltage	Working voltage (WV)	6.3	10	16	25	35	50	63	100	
	Surge voltage (SV)	8	13	20	32	44	63	79	125	
Low Temperature Characteristics	Working voltage (WV)	6.3	10	16	25	35	50	63	100	
	Impedance ratio	Z-25°C/Z+20°C	4	3	3	2	2	2	2	2
		Z-40°C/Z+20°C	8	6	6	4	4	3	3	3
Life Test	When returned to +20°C after 1,000 hours application of working voltage with the polarity inverted every 250 hours at +85°C, the capacitor will meet the following limits: Capacitance change is ≤±20% of initial value; tan δ is < 200% of initial specified value; leakage current is ≤ initial specified value									
Shelf Test	When returned to +20°C after 1,000 hours +85°C with no voltage applied, the capacitor will meet the following limits: Capacitance change is ≤±20% of initial value; tan δ is < 200% of initial specified value; leakage current is ≤ initial specified value									

PART NUMBERING SYSTEM

N P A L

Series

5 0 V

Voltage
Actual Value

2 2 0

Capacitance (μF)
Actual Value

■ DIMENSIONS AND PERMISSIBLE RIPPLE CURRENT

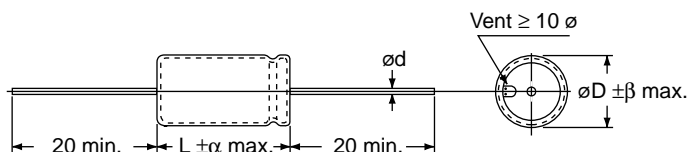

Lead Dimensions (mm)

øD	6.3	8	10	13	16	18
ød	0.6	0.6	0.6	0.8	0.8	0.8
β	1.5	1.5	1.5	2.0	2.0	2.0
α	0.5	0.5	0.5	1.0	1.0	1.0

Value (μF)	Working Voltage (WV); Dimensions: øD x L (mm); Ripple Current: mA/RMS @ 120Hz, 85°C															
	6.3		10		16		25		35		50		63		100	
	øD x L	mA	øD x L	mA	øD x L	mA	øD x L	mA	øD x L	mA	øD x L	mA	øD x L	mA	øD x L	mA
0.1											6.3 x 12	5	6.3 x 12	5	6.3 x 12	5
0.22											6.3 x 12	7	6.3 x 12	8	6.3 x 12	8
0.33											6.3 x 12	9	6.3 x 12	10	6.3 x 12	10
0.47											6.3 x 12	10	6.3 x 12	12	6.3 x 12	12
1											6.3 x 12	16	6.3 x 12	18	6.3 x 12	18
2.2											6.3 x 12	23	6.3 x 12	27	6.3 x 12	27
3.3											6.3 x 12	29	6.3 x 12	31	6.3 x 14	35
4.7											6.3 x 12	34	6.3 x 14	40	8 x 13	42
10									6.3 X 12	46	6.3 x 14	54	6.3 x 14	59	8 x 16	69
15											8 x 13	71				
22					6.3 x 12	61	6.3 x 16	69	6.3 x 14	74	8 x 16	89	10 x 17	97	10 x 21	120
33			6.3 x 12	71	6.3 x 12	80	8 x 13	85	8 x 16	101	8 x 16	109	10 x 21	139	13 x 22	153
47			8 x 13	85	8 X 13	95	8 x 16	113	8 X 16	120	10 x 17	152	10 x 21	174	13 x 22	203
100	6.3 x 16	118	8 x 13	147	8 x 16	155	10 x 17	192	10 x 21	205	10 x 21	232	13 x 22	269	16 x 27	317
220	8 x 16	195	8 x 16	254	10 x 17	268	10 x 21	298	13 x 22	338	13 x 27	381	16 x 27	447	16 x 37	501
330	8 x 16	239	10 x 17	312	10 x 21	344	13 x 22	387	13 X 27	433	16 x 27	500	16 x 33	567		
470	10 x 17	333	10 x 21	389	13 x 22	436	13 x 27	483	16 x 27	552	16 x 33	618	18 x 42	792		
1000	10 x 21	508	13 x 22	603	13 X 27	664	16 x 27	781	16 x 37	857	18 x 42	1054				
2200	13 x 27	836	16 x 28	1000	16 X 37	1121	18 x 42	1355								

Bi-Polar Audio Crossover Electrolytic Capacitors **BPRL Series**

FEATURES

- Radial lead, bi-polarized, suitable for crossover network in high-fidelity sound systems
- Has excellent high frequency characteristics
- Low leakage current and low dissipation factor
- Satisfies characteristic W of JIS-C-5141 standard



CHARACTERISTICS

Item	Characteristics			
Operating Temperature Range	-40°C ~ +85°C			
Capacitance Tolerance	±20% at +20°C, 1KHz			
Leakage Current	I = 0.03CWV or 3μA whichever is greater after 2 minutes of applied rated DC working voltage at 20°C Where: C = rated capacitance in μF; WV = rated DC working voltage			
Dissipation Factor (Tan δ, at +20°C 1KHz)	Capacitance (μF)	0.47 ~ 1.5	2.2 ~ 10	≥ 15
	Tan δ	0.12	0.10	0.08
Surge Voltage	Working voltage (WV)	50		
	Surge Voltage (sV)	63		
Low Temperature Characteristics	1. Capacitance at -40°C shall not be less than 80% of the value at 20°C 2. Impedance ratio at 120Hz: Z-25°C/Z+20°C is 2; Z-40°C/Z+20°C is 3			
Life Test	When returned to +20°C after 1,000 hours application of working voltage with the polarity reversed every 250 hours at +85°C, the capacitor will meet the following limits: Capacitance change is ≤ ±20% of initial value; tan δ is < 200% of initial specified value; leakage current is initial specified value			
Shelf Test	When returned to +20°C after 1,000 hours at +85°C with no voltage applied, the capacitor will meet the following limits: Capacitance change is ≤ ±20% of initial value; tan δ is < 200% of initial specified value; leakage current is initial specified value			

PART NUMBERING SYSTEM

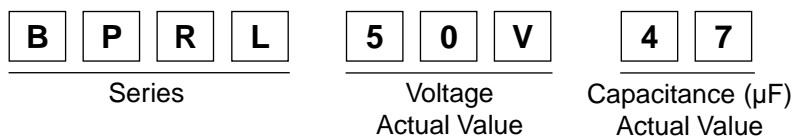

DIMENSIONS AND PERMISSIBLE RIPPLE CURRENT

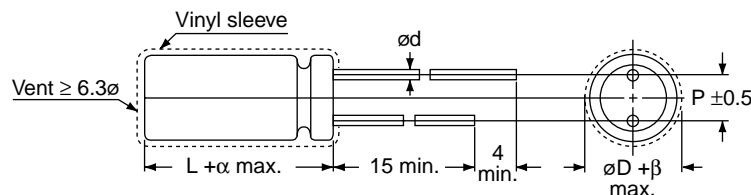

Lead Spacing and Diameter (mm)

øD	6.3	8	10	13	16	18	22
P	2.5	3.5	5.0	5.0	7.5	7.5	10
ød	0.5	0.5	0.6	0.6	0.8	0.8	1.0
β	0.5	0.5	0.5	0.5	0.5	0.5	0.5
α	1.0 for L ≤ 16; 2.0 for L ≥ 20						

Dimensions: øD x L (mm); Ripple Current: mA/RMS @ 1KHz, 85°C

Working Voltage: 50WVDC									
Value	øD x L	mA	Value	øD x L	mA	Value	øD x L	mA	
0.47	6.3 x 11	57	2.2	10 x 12.5	133	15	13 x 26	420	
0.56	6.3 x 11	57	3.3	10 x 16	182	22	10 x 26	480	
0.68	6.3 x 11	57	4.7	10 x 20	239	33	16 x 32	810	
0.82	6.3 x 11	57	6.8	13 x 21	280	47	18 x 36	1080	
1	8 x 11.5	76	8.2	13 x 21	305	68	22 x 42	1560	
1.5	8 x 11.5	93	10	10 x 16	365				



FEATURES

- 5mm height micro miniature size conserves space
- Ideal for high density circuits and miniaturized boards
- Satisfies characteristic W of JIS-C-5141 standard



CHARACTERISTICS

Item	Characteristics								
Operating Temperature Range	-40°C ~ +85°C								
Capacitance Tolerance	±20% at +20°C, 120Hz								
Leakage Current	I = 0.01CWV or 3μA whichever is greater after 2 minutes of applied rated DC working voltage at 20°C Where: C = rated capacitance in μF; WV = rated DC working voltage								
Dissipation Factor (Tan δ, at +20°C 120Hz)	Working voltage (WV)	4	6.3	10	16	25	35	50	
	Tan δ	0.35	0.25	0.20	0.17	0.15	0.13	0.10	
Surge Voltage	Working voltage (WV)	4	6.3	10	16	25	35	50	
	Surge voltage (SV)	5	8	13	20	32	44	63	
Low Temperature Characteristics	Working voltage (WV)	4	6.3	10	16	25	35	50	
	Imp. ratio @ 120Hz	Z-25°C/Z+20°C	7	6	4	3	2	2	2
		Z-40°C/Z+20°C	15	12	8	6	4	4	4
Life Test	When returned to +20°C after 1,000 hours application of working voltage at +85°C, the capacitor will meet the following limits: Capacitance change is ≤ ±30% of initial value for 4WV ~ 6.3WV and is ≤ ±25% of initial value for 10WV ~ 50WV; tan δ is < 200% of initial specified value; leakage current is ≤ initial specified value								
Shelf Test	When returned to +20°C after 1,000 hours at +85°C with no voltage applied, the capacitor will meet the following limits: Capacitance change is ≤ ±30% of initial value for 4WV ~ 6.3WV and is ≤ ±25% of initial value for 10WV ~ 50WV; tan δ is < 200% of initial specified value; leakage current is < 200% initial specified value								

PART NUMBERING SYSTEM

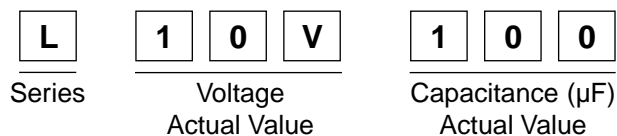

RIPPLE CURRENT AND FREQUENCY MULTIPLIERS

Capacitance (μF)	Frequency (Hz)				
	60 (50)	120	500	1K	≥10K
<47	0.75	1.0	1.15	1.34	1.50
47 ~ 220	0.80	1.0	1.08	1.20	1.30

RIPPLE CURRENT AND TEMPERATURE MULTIPLIERS

Temperature (°C)	<50	70	85
Multiplier	1.27	1.27	1.0



■ DIMENSIONS AND PERMISSIBLE RIPPLE CURRENT

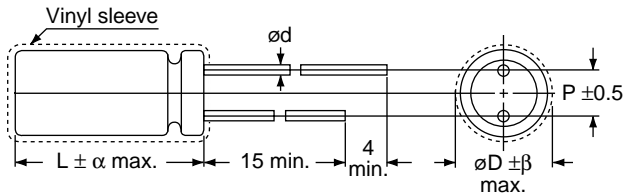

Lead Spacing and Diameter (mm)

ϕD	3	4	5	6.3
P	1.0	1.5	2.0	2.5
ϕd	0.4	0.45	0.45	0.45
β	1.0	1.0	1.0	1.0
α	0.5	0.5	0.5	0.5

Value (μF)	Working Voltage (WV); Dimensions: $\phi D \times L$ (mm); Ripple Current: mA/RMS @ 120Hz, 85°C													
	4		6.3		10		16		25		35		50	
	$\phi D \times L$	mA	$\phi D \times L$	mA	$\phi D \times L$	mA	$\phi D \times L$	mA	$\phi D \times L$	mA	$\phi D \times L$	mA	$\phi D \times L$	mA
0.1													3 x 5	1
0.22													3 x 5	2
0.33													3 x 5	2.8
0.47													3 x 5	4
1													3 x 5	7
2.2											3 x 5	7	4 x 5	10
3.3									3 x 5	10	4 x 5	12	4 x 5	13
4.7							3 x 5	11	4 x 5	17	4 x 5	14	5 x 5	20
10					3 x 5	13	4 x 5	23	5 x 5	27	5 x 5	27	6.3 x 5	31
22			4 x 5	22	5 x 5	30	5 x 5	35	6.3 x 5	42	6.3 x 5	46	6.3 x 5	46
33	4 x 5	27	5 x 5	34	5 x 5	41	6.3 x 5	49	6.3 x 5	52	6.3 x 5	52		
47	4 x 5	34	5 x 5	37	6.3 x 5	50	6.3 x 5	58	6.3 x 5	58				
100	5 x 5	55	6.3 x 5	62	6.3 x 5	70								
220	6.3 x 5	74												



■ FEATURES

- Ultraminiature and low profile size
- Low leakage current
- $\pm 20\%$ tolerance standard, $\pm 10\%$ tolerance available
- Can be replacement for tantalum
- Satisfies characteristic W of JIS-C-5141 standard

■ CHARACTERISTICS

Item	Characteristics								
Operating Temperature Range	-40°C ~ +85°C								
Capacitance Tolerance	$\pm 20\%$ at +20°C, 120Hz								
Leakage Current	I = 0.01CWV or 3 μ A whichever is greater after 2 minutes of applied rated DC working voltage at 20°C Where: C = rated capacitance in μ F; WV = rated DC working voltage								
Dissipation Factor (Tan δ , at +20°C 120Hz)	Working voltage (WV)	6.3	10	16	25	35	50	63	
	Tan δ	0.23	0.20	0.16	0.14	0.12	0.10	0.10	
Surge Voltage	Working voltage (WV)	6.3	10	16	25	35	50	63	
	Surge voltage (SV)	8	13	20	32	44	63	79	
Low Temperature Characteristics	Working voltage (WV)	6.3	10	16	25	35	50	63	
	Imp. ratio @ 120Hz	Z-25°C/Z+20°C	4	3	3	2	2	2	2
		Z-40°C/Z+20°C	10	8	6	4	4	4	4
Life Test	When returned to +20°C after 1,000 hours application of working voltage at +85°C, the capacitor will meet the following limits: Capacitance change is $\leq \pm 20\%$ of initial value; tan δ is $\leq 200\%$ of initial specified value; leakage current is initial specified value								
Shelf Test	When returned to +20°C after 1,000 hours at +85°C with no voltage applied, the capacitor will meet the following limits: Capacitance change is $\leq \pm 20\%$ of initial value; tan δ is $\leq 200\%$ of initial specified value; leakage current is $\leq 200\%$ of initial specified value								

■ PART NUMBERING SYSTEM

M	L	R	L	1	0	V	1	0	0
Series				Voltage Actual Value			Capacitance (μ F) Actual Value		

■ DIMENSIONS AND PERMISSIBLE RIPPLE CURRENT

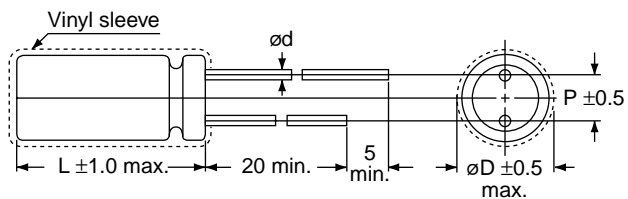

Lead Spacing and Diameter (mm)

øD	4	5	6	8
P	1.5	2.0	2.5	3.5
ød	0.45	0.50	0.50	0.50

Value (μ F)	Working Voltage (WV); Dimensions: D x H (mm); Ripple Current: mA/RMS @ 120Hz, 85°C													
	6.3		10		16		25		35		50		60	
	D x H	Ω	D x H	Ω	D x H	Ω	D x H	Ω	D x H	Ω	D x H	Ω	D x H	Ω
0.1													4 x 7	2
0.15													4 x 7	2
0.22													4 x 7	3
0.33													4 x 7	4
0.47													4 x 7	5
0.68													4 x 7	6
1													4 x 7	8
1.5													4 x 7	11
2.2													4 x 7	15
3.3											4 x 7	14	5 x 7	15
4.7									4 x 7	16	5 x 7	18	6 x 7	19
6.8							4 x 7	16	5 x 7	16	6 x 7	23		
10					4 x 7	21	4 x 7	21	5 x 7	24	6 x 7	28		
15					4 x 7	21	5 x 7	24	5 x 7	29				
22			4 x 7	27	4 x 7	30	5 x 7	33	6 x 7	37				
33	4 x 7	32	4 x 7	35	5 x 7	38	6 x 7	41	8 x 9	53				
47	4 x 7	38	5 x 7	41	6 x 7	48	6 x 7	49	8 x 9	63				
68	5 x 7	48	6 x 7	58	6 x 7	53	8 x 9	51						
100	5 x 7	58	6 x 7	63	6 x 7	68								
150	6 x 7	99	8 x 9	87										
220	6 x 7	99	8 x 9	106										

■ FEATURES

- Has snap-in terminals, which can be soldered to the PCB directly
- Suitable for electronic equipment with middle-high voltage circuits
- Vented cans for safety
- Excellent temperature performance

■ CHARACTERISTICS

Item	Characteristics										
Operating Temperature Range	16WV ~ 100WV is -40°C ~ +85°C; 160WV ~ 250WV is -25°C ~ +85°C										
Capacitance Tolerance	±20% at 20°C, 120Hz										
Leakage Current	For 16WV ~ 100WV: $I = 0.04CWV + 30\mu A$ or 3mA; for 160WV ~ 250WV: $I = 0.06CWV + 200\mu A$ or 5mA whichever is smaller after 5 minutes of applied rated DC working voltage at 20°C Where: C = rated capacitance in μF ; WV = rated DC working voltage										
Dissipation Factor (Tan δ , at 20°C 120Hz)	Working voltage (WV)	16	25	35	50	63	100	160	200	250	
	Tan δ	C ≤ 100,000	0.40	0.40	0.30	0.30	0.30	0.20	0.20	0.18	0.18
		C > 100,000; ≤ 330,000	0.50	0.50	0.40	0.40	0.40	0.35	0.35	0.30	0.30
	C > 330,000	0.60	0.60	0.50	0.50	0.50	0.45	0.45	0.40	0.40	
Temperature Characteristics	Imp. Ratio	Z -25°C / Z +20°C	4	4	4	4	4	4	8	8	8
		Z -40°C / Z +20°C	12	12	12	12	12	12	---	---	---
Life Test	When returned to +20°C after 1,000 hours application of working voltage at +85°C, the capacitor will meet the following limits: Capacitance change is ≤ ±20%; tan δ is <200% of initial specified value; leakage current is within initial specified value										
Shelf Test	When returned to +20°C after 500 hours at +85°C with no voltage applied, the capacitor will meet the following limits: Capacitance change is ±20%; tan δ is <200% of initial specified value; leakage current is within initial specified value										

PART NUMBERING SYSTEM

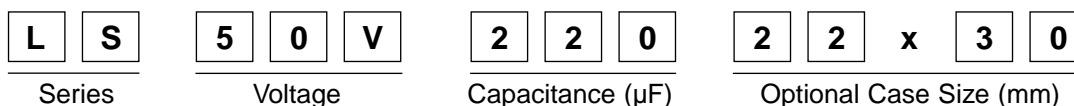

■ RIPPLE CURRENT AND FREQUENCY MULTIPLIERS

Working Voltage (WV)	Frequency (Hz)				
	60 (50)	120	1K	10K	20K
≤100	0.95	1.0	1.10	1.30	1.33
≥160	0.90	1.0	1.20	1.50	1.55

■ RIPPLE CURRENT AND TEMPERATURE MULTIPLIERS

Temperature (°C)	40	55	70	85
Multiplier	2.1	1.8	1.5	1.0



■ DIMENSIONS AND PERMISSIBLE RIPPLE CURRENT

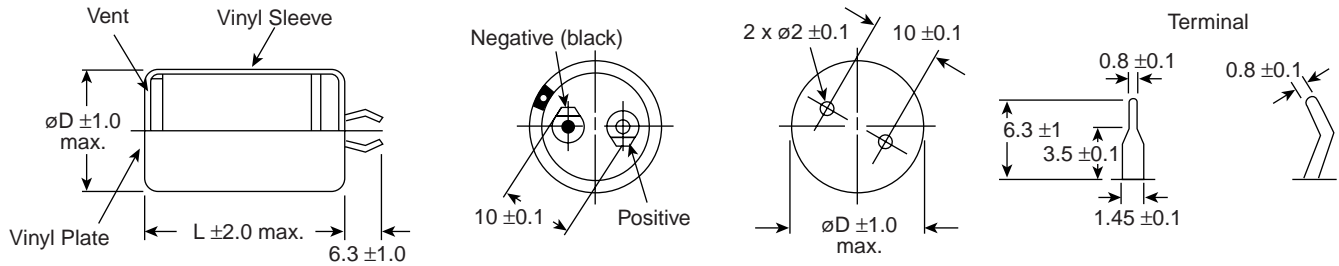

Value (μF)	Working Voltage (WV); Dimensions: $\varnothing D \times L$ (mm); Ripple Current A/RMS @ 120Hz, 85°C																			
	16		25		35		50		63		100		160		200		250			
	$\varnothing D \times L$	A/rms	$\varnothing D \times L$	A/rms	$\varnothing D \times L$	A/rms	$\varnothing D \times L$	A/rms	$\varnothing D \times L$	A/rms	$\varnothing D \times L$	A/rms	$\varnothing D \times L$	A/rms	$\varnothing D \times L$	A/rms	$\varnothing D \times L$	A/rms		
150														22 x 25	0.4	22 x 30	0.4	22 x 30	0.4	
																		22 x 53	0.5	
220														22 x 30	0.5	22 x 40	0.6	22 x 40	0.6	
														22 x 40	0.6	22 x 53	0.7	22 x 59	0.7	
330														22 x 40	0.7	25 x 40	0.8	25 x 40	0.8	
														22 x 51	0.8	25 x 65	1.0	25 x 65	1.0	
470													22 x 25	0.6	25 x 40	0.9	25 x 40	0.9	25 x 50	0.8
													22 x 30	0.7	25 x 64	1.1	25 x 64	1.1		
680									22 x 25	0.6	22 x 30	0.9	25 x 50	0.8	25 x 50	0.9	30 x 50	1.0		
											22 x 40	1.0	30 x 64	1.0						
1000					22 x 25	0.8	22 x 25	0.8	22 x 25	0.7	22 x 40	1.2	30 x 40	1.0	30 x 50	1.2	30 x 60	1.34		
									22 x 30	0.8	25 x 40	1.3								
1500					22 x 25	1.0	22 x 30	1.0	22 x 30	1.0	22 x 40	1.1								
									22 x 40	1.2	25 x 52	1.3								
2200			22 x 25	1.0	22 x 25	1.1	22 x 30	1.1	25 x 40	1.3	30 x 40	1.5								
							22 x 40	1.2	22 x 40	1.2	30 x 52	1.7								
3300	22 x 25	1.2	22 x 25	1.2	22 x 30	1.3	22 x 40	1.5	25 x 40	1.6	30 x 50	2.1								
			22 x 30	2.0	22 x 40	1.5	25 x 40	1.6	25 x 52	1.8										
4700	22 x 25	1.4	22 x 30	1.4	22 x 40	1.8	25 x 40	1.9	30 x 40	2.1										
			22 x 40	1.6	25 x 40	1.9	25 x 50	2.1	30 x 52	2.3										
6800	22 x 40	1.9	22 x 40	1.9	25 x 40	2.3	30 x 40	2.2	30 x 40	2.2										
			25 x 40	2.0	25 x 52	2.5	30 x 52	2.5	30 x 52	2.5										
10000	22 x 40	2.3	25 x 40	2.5	30 x 40	2.7	30 x 50	3.0	30 x 50	3.0										
	25 x 40	2.5	25 x 52	2.7	30 x 52	3.0														
15000	25 x 40	3.0	30 x 40	3.0	30 x 50	3.7														
	30 x 40	3.3	30 x 52	3.4																
22000	30 x 40	4.0	30 x 50	3.7																
	30 x 52	4.5																		

Plastic film capacitors are now widely used by the electronics industry, and their selection is based upon the following factors:

Frequency:

Polyester capacitors have higher dielectric losses and as a result are generally suitable at frequencies of 10KHz or less. They have a wider temperature range than the other common use dielectric materials and due to a higher dielectric constant can produce high capacitance values in smaller package dimensions.

Polypropylene capacitors have relatively low dissipation factors and dielectric losses, and as such they are suitable for high voltages, high frequencies and high pulse currents. They are larger in size, have a narrow temperature range and negative temperature coefficient. Polypropylene capacitors are suitable for blocking, bypass, coupling, and temperature compensation circuits. They have applications in telecommunications, data processing, industrial instrumentation, and automatic control systems. Metallized polypropylene capacitors are suitable for the above applications as well as for filtering, decoupling, timing, and tuning.

Polycarbonate capacitors have moderate features of both polyester & polypropylene styles, but are more expensive. They offer more stable capacitance versus temperature characteristics and good long term stability.

Polystyrene capacitors have excellent high frequency performance due to their low dissipation factor and very low dielectric absorption characteristics.

Metallized polyester box capacitors have a non-inductive construction. They are suitable for filtering, bypass, coupling, decoupling, and timing circuits. They have applications in telecommunications, data processing, industrial instrumentation, and automatic control systems.

Peak Voltage:

The peak voltage against a zero potential reference should always be less than the nominal DC voltage rating of the capacitor. The rate of voltage change (dv/dt) of individual specifications is valid for pulse voltages equal to or less than the rated DC voltage. If the pulse voltage is less, then a factor of "VDC/applied voltage" may be used.

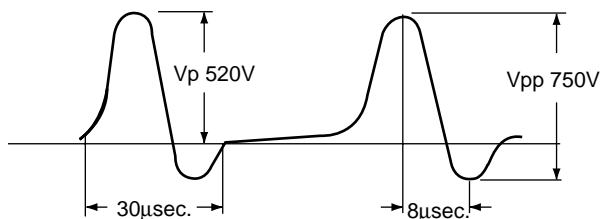

$V_{rms} \leq V_{AC}$ rated for sinusoidal wave

$V_p \leq V_{DC}$ rated and the V_{rms} voltage derived from the peak voltage should always be less than the nominal AC voltage rating of the capacitor.

$$V_{rms} = \frac{V_{p-p}}{\sqrt{2}}$$

Permissible Current:

Under AC operation, the permissible current must be less than A_{p-p} . High currents may deteriorate performance and damage the capacitor due to internal temperature rise.

Inherent Temperature Rise:

When a capacitor is operated in an AC circuit, especially at high frequency, the temperature of the capacitor rises. In case the temperature rises too high, the performance of the capacitor may suffer or the capacitor be damaged. The inherent temperature rise with no air circulation (Ambient temp. at 40°C) should be kept within the specified limits. (The allowable value depends on the dielectric. For details, consult our office or sales representative.)

FEATURES

- Constructed of metallized polyester film
- High stability in a miniature size
- Self healing characteristics with dipped epoxy coating to retard humidity defects
- Non-inductive construction



CHARACTERISTICS

Item	Characteristics
Operating Temperature Range	-40°C ~ +85°C
Capacitance Tolerance	±5%, ±10%, ±20%
Standard Working Voltage (WV)	100, 250, 400, 630
Dielectric Strength	150% of working voltage for 1 minute
Dissipation Factor	1.0% max. (1KHz), 20°C

PART NUMBERING SYSTEM

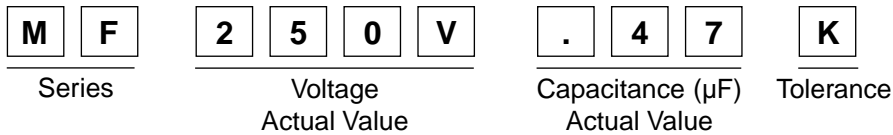

Tolerance Code:
J = ±5%
K = ±10%
M = ±20%

TEMPERATURE CHARACTERISTIC CHARTS

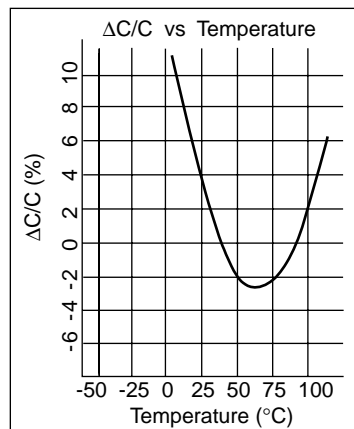
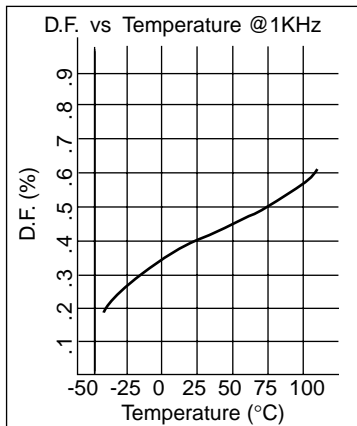

■ DIMENSIONS

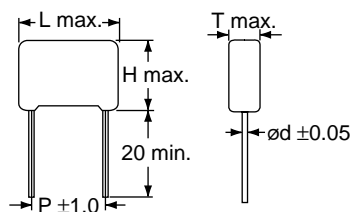

Value (µF)	Working Voltage (WV); Dimensions (mm)											
	100			250			400			630		
	L x H x T	P	ød	L x H x T	P	ød	L x H x T	P	ød	L x H x T	P	ød
0.0033				12.5x8.5x4.5	10	0.6	12.5x9.0x5.0	10	0.6	12.5x9.5x5.5	10	0.6
0.0039				12.5x8.5x4.5	10	0.6	12.5x9.0x5.0	10	0.6	12.5x9.5x5.5	10	0.6
0.0047				12.5x8.5x4.5	10	0.6	12.5x9.0x5.0	10	0.6	12.5x9.5x5.5	10	0.6
0.0056				12.5x8.5x4.5	10	0.6	12.5x9.0x5.0	10	0.6	12.5x9.5x5.5	10	0.6
0.0068				12.5x8.5x4.5	10	0.6	12.5x9.0x5.0	10	0.6	12.5x9.5x5.5	10	0.6
0.0082				12.5x9.0x5.0	10	0.6	12.5x9.0x5.0	10	0.6	12.5x9.5x5.5	10	0.6
0.010				12.5x9.0x5.0	10	0.6	12.5x9.0x5.0	10	0.6	12.5x9.5x5.5	10	0.6
0.012				12.5x9.0x5.0	10	0.6	12.5x9.0x5.0	10	0.6	12.5x9.5x5.5	10	0.6
0.015				12.5x9.0x5.0	10	0.6	12.5x9.0x5.0	10	0.6	12.5x10.0x5.5	10	0.6
0.018				12.5x9.0x5.0	10	0.6	12.5x9.0x5.0	10	0.6	12.5x10.0x5.5	10	0.6
0.022				12.5x9.0x5.0	10	0.6	12.5x9.0x5.0	10	0.6	12.5x11.0x6.0	10	0.6
0.027				12.5x9.0x5.0	10	0.6	12.5x9.5x5.5	10	0.6	12.5x11.5x6.5	10	0.6
0.033				12.5x9.0x5.0	10	0.6	12.5x9.5x5.5	10	0.6	18.0x11.0x6.0	15	0.8
0.039				12.5x9.0x5.0	10	0.6	12.5x10.0x6.0	10	0.6	18.0x11.0x6.0	15	0.8
0.047				12.5x9.0x5.0	10	0.6	12.5x11.0x6.5	10	0.6	18.0x12.0x6.5	15	0.8
0.056				12.5x9.0x5.0	10	0.6	12.5x12.0x7.0	10	0.6	18.0x12.5x6.5	15	0.8
0.068				12.5x9.0x5.0	10	0.6	18.0x10.0x5.5	15	0.8	18.0x13.0x7.0	15	0.8
0.082				12.5x9.0x5.0	10	0.6	18.0x11.0x6.0	15	0.8	23.0x12.0x6.5	20	0.8
0.10				12.5x9.0x5.0	10	0.6	18.0x11.0x6.0	15	0.8	23.0x13.0x7.0	20	0.8
0.12	12.5x9.0x5.0	10	0.6	12.5x9.5x5.5	10	0.6	18.0x12.0x6.5	15	0.8	23.0x14.0x7.5	20	0.8
0.15	12.5x9.0x5.0	10	0.6	12.5x10.0x6.0	10	0.6	18.0x13.0x7.0	15	0.8	23.0x15.0x8.5	20	0.8
0.18	12.5x9.0x5.0	10	0.6	18.0x10.0x5.5	15	0.8	18.0x14.0x7.5	15	0.8	23.0x16.0x9.0	20	0.8
0.22	12.5x9.0x5.0	10	0.6	18.0x11.0x6.0	15	0.8	18.0x15.5x8.5	15	0.8	23.0x16.5x9.5	20	0.8
0.27	12.5x9.0x5.0	10	0.6	18.0x12.0x6.5	15	0.8	23.0x15.0x8.0	20	0.8	31.0x17.0x8.0	27	0.8
0.33	12.5x9.5x5.5	10	0.6	18.0x13.0x7.0	15	0.8	23.0x16.0x9.0	20	0.8	31.0x18.0x9.5	27	0.8
0.39	12.5x10.0x6.0	10	0.6	18.0x14.0x7.5	15	0.8	23.0x17.0x10	20	0.8	31.0x20.0x11	27	0.8
0.47	12.5x11.0x6.5	10	0.6	22.0x11.0x5.0	20	0.8	23.0x18.0x11	20	0.8	31.0x21.0x12	27	0.8
0.56	18.0x12.0x6.5	15	0.8	23.0x13.0x7.0	20	0.8	23.0x19.0x12	20	0.8	31.0x22.5x13	27	0.8
0.68	18.0x13.0x7.0	15	0.8	23.0x14.0x7.5	20	0.8	31.0x18.0x9.5	27	0.8	31.0x24.0x14	27	0.8
0.82	18.0x14.0x7.5	15	0.8	23.0x15.0x8.0	20	0.8	31.0x19.0x10	27	0.8			
1.0	18.0x14.5x8.0	15	0.8	23.0x16.0x9.0	20	0.8	31.0x20.0x11	27	0.8	31.0x27x18	27	
1.2	18.0x15.5x9.0	15	0.8	23.0x17.0x10	20	0.8	31.0x22.0x13	27	0.8			
1.5	23.0x15.0x8.0	20	0.8	31.0x17.0x9.0	27	0.8	31.0x24.0x15	27	0.8			
1.8	23.0x16.0x9.0	20	0.8	31.0x18.0x9.5	27	0.8	31.0x25.5x16.5	27	0.8			
2.2	23.0x17.0x10	20	0.8	31.0x19.0x10	27	0.8	31.0x27.0x18	27	0.8			
2.7	23.0x18.5x11	20	0.8	31.0x20.5x11.5	27	0.8						
3.3	23.0x20.0x12	20	0.8	31.0x22.0x13.5	27	0.8						
3.9	31.0x18.0x11.5	27	0.8	31.0x23.0x15.0	27	0.8						
4.7	31.0x20.0x13	27	0.8	31.0x24.0x16.0	27	0.8						
5.6	31.0x22.0x14.5	27	0.8									
6.8	31.0x24.0x16	27	0.8									



FEATURES

- Non-inductive
- Sealed with epoxy resin
- Self healing
- Excellent for use in coupling, RF filters, and solid state circuits

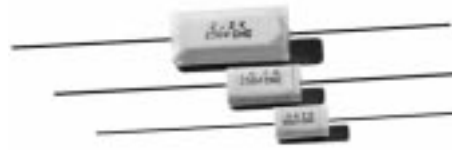

23MA Series



23ME Series

CHARACTERISTICS

Item	Characteristics
Operating Temperature Range	-40°C ~ +85°C
Capacitance Tolerance	±10% standard, other tolerances available upon request, ask for details
Standard Working Voltage (WV)	100, 250, 400, 630, 1000
Dielectric Strength	150% of working voltage for 1 minute
Dissipation Factor	1.0% max. (1KHz), 20°C
Insulation Resistance	<.33μF is >15,000MΩ; ≥.33μF is >5,000MΩ per μF

PART NUMBERING SYSTEM

2	3	M	E	5	1	0
Voltage	Series		Type	Capacitance (pF)		

Voltage Code:	
1	= 100
2	= 250
4	= 400
6	= 630
10	= 1000 (Type E only)

■ DIMENSIONS: LEAD DIAMETER AND LENGTH, TYPE A AND E

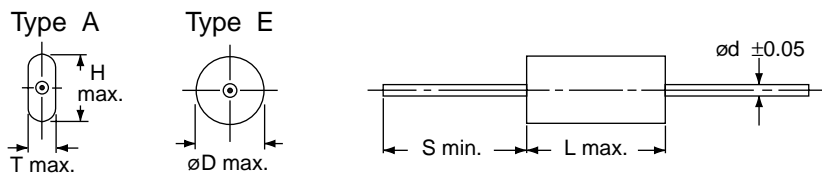

Lead Dimensions (mm)

L	10.5	14.0	19.0	25.0	32.0	47.0	58.0
ød	0.6	0.6	0.8	0.8	0.8	0.8	1.0
S	30	30	35	35	35	35	35

■ LENGTH, HEIGHT, AND WIDTH, TYPE A

Value (µF)	Working Voltage (WVDC); Dimensions (mm) L x H x T			
	100	250	400	630
.047			14.0x12.0x4.5	19.0x11.0x6.0
.056				19.0x11.0x6.0
.068			19.0x9.0x5.0	19.0x11.0x6.0
.082			19.0x10.0x5.5	19.0x12.0x6.5
.1	10.5x8.5x4.5	14.0x8.5x4.5	19.0x10.0x5.5	19.0x12.0x6.5
.12	10.5x8.5x4.5	14.0x8.5x4.5	19.0x11.0x6.0	19.0x13.0x7.0
.15	10.5x8.5x4.5	14.0x9.0x5.0	19.0x12.0x6.5	19.0x14.0x7.5
.18	10.5x8.5x4.5	14.0x9.5x5.5	19.0x13.0x7.0	25.0x14.0x7.5
.22	14.0x8.5x4.5	14.0x10.0x6.0	19.0x14.0x7.5	25.0x15.0x8.5
.27	14.0x8.5x4.5	19.0x11.0x6.0	25.0x13.0x7.0	32.0x16.0x7.0
.33	14.0x9.0x5.0	19.0x12.0x6.5	25.0x14.0x7.5	32.0x17.0x8.0
.39	14.0x9.0x5.0	19.0x13.0x7.0	25.0x15.0x8.0	32.0x18.0x9.0
.47	14.0x9.0x5.0	19.0x13.0x7.0	25.0x16.0x9.0	32.0x19.0x10.0
.56	14.0x9.5x5.5	25.0x12.0x6.0	25.0x17.0x10.0	32.0x20.0x11.0
.68	19.0x10.5x5.5	25.0x12.5x6.5	32.0x17.0x9.0	32.0x21.5x12.5
.82	19.0x11.0x6.0	25.0x13.0x7.0	32.0x18.0x9.5	32.0x22.5x13.5
1.0	19.0x12.0x6.5	25.0x14.0x7.5	32.0x19.0x10.0	32.0x24.0x15.0
1.2	19.0x13.0x7.0	25.0x15.0x8.0	32.0x20.5x11.5	47.0x22.0x12.0
1.5	25.0x13.0x7.0	32.0x16.0x8.5	32.0x22.0x13.0	47.0x24.0x14.0
1.8	25.0x14.0x7.5	32.0x17.0x9.0	32.0x24.5x15.5	47.0x25.0x15.0
2.2	25.0x15.0x8.0	32.0x18.0x9.5	32.0x26.0x17.0	47.0x26.5x16.5
2.7	25.0x15.5x8.5	32.0x19.0x10.0	47.0x23.0x13.0	47.0x29.0x19.0
3.3	25.0x16.0x9.0	32.0x20.0x11.0	47.0x25.0x15.0	47.0x32.0x22.0
3.9	32.0x17.0x10.0	32.0x21.0x12.0	47.0x27.0x17.0	47.0x34.0x24.0
4.7	32.0x18.0x11.0	47.0x21.0x11.0	47.0x29.0x19.0	47.0x36.0x26.0
5.6	32.0x19.5x12.5	47.0x22.0x12.0	47.0x31.0x21.0	58.0x35.0x25.0
6.8	32.0x21.0x14.0	47.0x23.0x13.0	47.0x33.0x23.0	58.0x37.0x27.0
8.2	32.0x23.0x16.0	47.0x25.0x15.0	58.0x34.0x24.0	
10.0	47.0x21.0x12.0	47.0x26.5x16.5	58.0x36.0x26.0	
12.0	47.0x22.0x13.0	47.0x28.0x18.0		
15.0	47.0x24.0x15.0	47.0x30.0x20.0		
18.0	47.0x26.0x17.0	58.0x31.0x21.0		
20.0	47.0x28.0x18.0	58.0x32.0x22.0		
22.0	47.0x29.0x19.0	58.0x33.0x23.0		
25.0	47.0x30.0x20.0	58.0x35.0x25.0		
27.0	47.0x31.0x21.0	58.0x36.0x26.0		
30.0	47.0x33.0x23.0	58.0x38.0x28.0		
33.0	47.0x35.0x25.0	58.0x40.0x30.0		
39.0	47.0x37.0x27.0			
47.0	47.0x40.0x30.0			

■ DIAMETER AND LENGTH, TYPE E

Value (µF)	Working Voltage (WVDC); Dimensions (mm) øD x L				
	100	250	400	630	1000
.01	5.0x10.5	5.5x14.0	5.5x14.0	6.0x14.0	8.0x19.0
.012	5.0x10.5	5.5x14.0	5.5x14.0	6.0x14.0	8.0x19.0
.015	5.0x10.5	5.5x14.0	5.5x14.0	6.5x14.0	8.0x19.0
.018	5.0x10.5	5.5x14.0	5.5x14.0	6.5x14.0	8.5x19.0
.022	5.0x10.5	5.5x14.0	5.5x14.0	6.5x14.0	9.0x19.0
.027	5.0x10.5	5.5x14.0	6.0x14.0	6.5x14.0	10.0x19.0
.033	5.0x10.5	5.5x14.0	6.0x14.0	6.5x19.0	10.0x19.0
.039	5.0x10.5	5.5x14.0	6.5x14.0	7.0x19.0	10.5x25.0
.047	5.0x10.5	5.5x14.0	7.0x14.0	7.5x19.0	10.5x25.0
.056	5.0x10.5	5.5x14.0	7.5x14.0	8.0x19.0	11.0x25.0
.068	5.0x10.5	5.5x14.0	6.5x19.0	8.5x19.0	11.5x25.0
.082	5.5x10.5	5.5x14.0	7.0x19.0	8.0x25.0	11.5x32.0
.1	5.5x10.5	6.0x14.0	7.5x19.0	9.0x25.0	12.0x32.0
.12	6.0x10.5	6.5x14.0	8.0x19.0	10.0x25.0	13.0x32.0
.15	6.5x10.5	6.5x14.0	8.5x19.0	10.5x25.0	14.0x32.0
.18	6.0x14.0	7.0x19.0	9.0x19.0	11.0x25.0	15.0x32.0
.22	6.0x14.0	7.0x19.0	10.0x19.0	12.0x25.0	16.0x32.0
.27	6.5x14.0	7.5x19.0	9.5x25.0	11.0x32.0	17.0x32.0
.33	7.0x14.0	8.0x19.0	10.0x25.0	12.0x32.0	17.0x47.0
.39	7.5x14.0	8.5x19.0	11.0x25.0	13.0x32.0	18.0x47.0
.47	8.0x14.0	9.0x19.0	11.5x25.0	14.0x32.0	19.0x47.0
.56	7.5x19.0	10.0x19.0	12.5x25.0	15.0x32.0	20.0x47.0
.68	8.0x19.0	10.0x25.0	13.0x32.0	16.5x32.0	22.0x47.0
.82	8.5x19.0	11.0x25.0	14.0x32.0	18.0x32.0	24.0x47.0
1.0	9.0x19.0	12.0x25.0	15.0x32.0	20.0x32.0	26.0x47.0
1.2	10.0x19.0	13.0x25.0	16.5x32.0	17.5x47.0	
1.5	10.0x25.0	14.0x25.0	18.0x32.0	19.0x47.0	
1.8	11.0x25.0	13.0x32.0	19.0x32.0	21.0x47.0	
2.2	12.0x25.0	14.0x32.0	20.0x32.0	23.0x47.0	
2.7	13.0x25.0	15.0x32.0	19.0x47.0	25.0x47.0	
3.3	14.0x25.0	16.5x32.0	20.0x47.0	27.0x47.0	
3.9	13.0x32.0	18.0x32.0	21.0x47.0	29.0x47.0	
4.7	14.0x32.0	16.0x47.0	23.0x47.0	31.0x47.0	
5.6	15.0x32.0	17.0x47.0	24.5x47.0		
6.8	16.5x32.0	18.5x47.0	26.0x47.0		
8.2	18.0x32.0	20.0x47.0			
10.0	18.0x47.0	22.0x47.0			
12.0	19.5x47.0	24.0x47.0			
15.0	21.0x47.0	26.0x47.0			
18.0	22.0x47.0	26.0x58.0			
22.0	25.0x47.0	29.0x58.0			
27.0	27.0x47.0	32.0x58.0			
30.0	29.0x47.0	34.0x58.0			



Metallized Polyester Film Box Capacitors Class X2 MEX Series

FEATURES

- For interference suppression and across-line capacitor class X-2
- Non-inductive construction
- High-moisture resistance
- Good solderability
- Flame retardant plastic case with epoxy resin sealing (compliant with UL94V-0)
- Ideal for EMI filter and switching power supplies
- UL and CSA listed



CHARACTERISTICS

Items	Characteristics
Operating Temperature Range	-40°C ~ +85°C
Capacitance Range	.01μF ~ 0.47μF
Capacitance Tolerance	±20% standard, other tolerances available upon request, ask for details
Working Voltage	250VAC 50-60Hz
Dissipation Factor	0.75% max. @ 1KHz, 25°C
Insulation Resistance @ 25°C	≤.33μF is >30,000MΩ; >.33μF is >10,000MΩ
Lead Material	Copper clad steel
Dielectric Strength	2100VDC for 5 seconds

PART NUMBERING SYSTEM

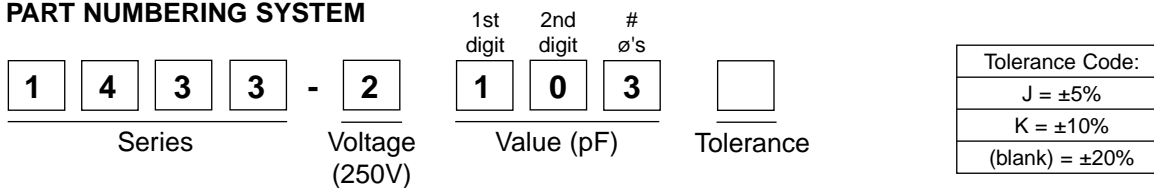

DIMENSIONS

Value (μF)	Dimensions (mm)				
	W	H	T	P	ød
0.01	13.0	11.0	5.0	10.0	0.6
0.012	13.0	11.0	5.0	10.0	0.6
0.015	13.0	12.0	6.0	10.0	0.6
0.018	13.0	12.0	6.0	10.0	0.6
0.022	13.0	12.0	6.0	10.0	0.6
0.027	13.0	13.0	7.0	10.0	0.6
0.033	18.0	11.0	5.0	15.0	0.8
0.039	18.0	11.0	5.0	15.0	0.8
0.047	18.0	12.0	6.0	15.0	0.8
0.056	18.0	12.0	6.0	15.0	0.8
0.068	18.0	13.5	7.5	15.0	0.8
0.082	18.0	13.5	7.5	15.0	0.8
0.1	18.0	13.5	7.5	15.0	0.8
0.12	18.0	15.0	8.5	15.0	0.8
0.15	26.5	17.0	8.5	22.5	0.8
0.18	26.5	17.0	8.5	22.5	0.8
0.22	26.5	19.0	10.0	22.5	0.8
0.27	32.0	20.0	11.0	27.5	0.8
0.33	32.0	20.0	11.0	27.5	0.8
0.39	32.0	22.0	13.0	27.5	0.8
0.47	32.0	22.0	13.0	27.5	0.8

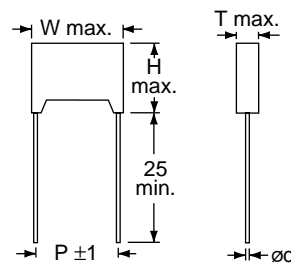

FEATURES

- Self healing, non-inductive construction
- High-moisture resistance
- Good solderability
- Flame retardant plastic case with epoxy resin sealing (compliant with UL94V-0)



CHARACTERISTICS

Items	Characteristics
Operating Temperature Range	-40°C ~ +85°C
Capacitance Tolerance	±5%, ±10%, ±20%
Working Voltage (WV)	100, 250, 400, 630
Dissipation Factor	1.0% max. (1KHz), 25°C
Insulation Resistance	≤.33μF is >10,000MΩ; >.33μF is >3300MΩ per μF

PART NUMBERING SYSTEM

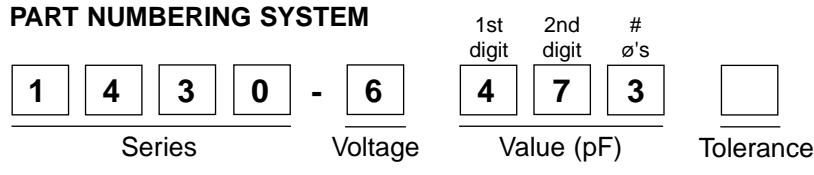

Voltage Code:
1 = 100
2 = 250
4 = 400
6 = 630

Tolerance Code:
J = ±5%
(blank) = ±10%
M = ±20%

DIMENSIONS

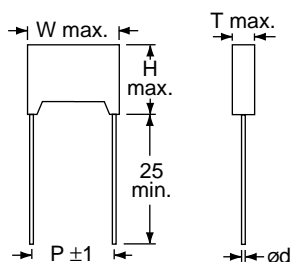

Value (μF)	Working Voltage (WV); Dimensions (mm)											
	100			250			400			630		
	W x H x T	P	ød	W x H x T	P	ød	W x H x T	P	ød	W x H x T	P	ød
0.01	10.5 x 9.0 x 4.0	7.5	0.6	10.5 x 9.0 x 4.0	7.5	0.6	13.0 x 11.0 x 5.0	10	0.6	13.0 x 9.0 x 4.0	10	0.6
0.015	10.5 x 9.0 x 4.0	7.5	0.6	10.5 x 9.0 x 4.0	7.5	0.6	13.0 x 11.0 x 5.0	10	0.6	13.0 x 11.0 x 5.0	10	0.6
0.022	10.5 x 9.0 x 4.0	7.5	0.6	10.5 x 9.0 x 4.0	7.5	0.6	13.0 x 11.0 x 5.0	10	0.6	13.0 x 12.0 x 6.0	10	0.6
0.033	10.5 x 9.0 x 4.0	7.5	0.6	10.5 x 9.0 x 4.0	7.5	0.6	13.0 x 12.0 x 6.0	10	0.6	18.0 x 11.0 x 15.0	15	0.6
0.047	10.5 x 9.0 x 4.0	7.5	0.6	13.0 x 9.0 x 4.0	10	0.6	13.0 x 12.0 x 6.0	10	0.6	18.0 x 12.0 x 6.0	15	0.8
0.068	10.5 x 9.0 x 4.0	7.5	0.6	13.0 x 9.0 x 4.0	10	0.6	18.0 x 11.0 x 5.0	15	0.8	18.0 x 13.5 x 7.5	15	0.8
0.1	13.0 x 11.0 x 5.0	10	0.6	13.0 x 11.0 x 5.0	10	0.6	18.0 x 12.0 x 6.0	15	0.8	22.5 x 15.0 x 6.0	22.5	0.8
0.15	13.0 x 11.0 x 5.0	10	0.6	18.0 x 11.0 x 5.0	15	0.8	18.0 x 14.0 x 7.5	15	0.8	26.5 x 16.5 x 7.0	22.5	0.8
0.22	13.0 x 11.0 x 5.0	10	0.6	18.0 x 11.0 x 5.0	15	0.8	26.5 x 15.0 x 6.0	22.5	0.8	26.5 x 17.0 x 8.5	22.5	0.8
0.33	13.0 x 12.0 x 6.0	10	0.6	18.0 x 12.0 x 6.0	15	0.8	26.5 x 16.5 x 7.0	22.5	0.8	32.0 x 20.0 x 11.0	27.5	0.8
0.47	18.0 x 11.0 x 5.0	15	0.8	18.0 x 14.0 x 7.5	15	0.8	26.5 x 17.0 x 8.5	22.5	0.8	32.0 x 22.0 x 13.0	27.5	0.8
0.68	18.0 x 12.0 x 6.0	15	0.8	26.5 x 16.5 x 7.0	22.5	0.8	32.0 x 20.0 x 11.0	27.5	0.8			
1.0	18.0 x 14.0 x 7.5	15	0.8	26.5 x 17.0 x 8.5	22.5	0.8	32.0 x 20.0 x 11.0	27.5	0.8			
1.5	26.5 x 16.5 x 7.0	22.5	0.8	26.5 x 19.0 x 10.0	22.5	0.8						
2.2	26.5 x 17.0 x 8.5	22.5	0.8	32.0 x 20.0 x 11.0	27.5	0.8						
3.3	26.5 x 19.0 x 10.0	22.5	0.8	32.0 x 22.0 x 13.0	27.5	0.8						
4.7	32.0 x 20.0 x 11.0	27.5	0.8									
6.8	32.0 x 22.0 x 13.0	27.5	0.8									



FEATURES

- Low dissipation factor
- High insulation resistance
- High stability of capacitance and DF versus temperature and frequency
- Self-healing properties
- Non-inductive



CHARACTERISTICS

Item	Characteristics
Operating Temperature Range	-40°C ~ +85°C
Capacitance Tolerance	±5%, ±10%, ±20%
Standard Working Voltage (WV)	250, 400, 630
Dissipation Factor	0.1% max. (1KHz), 25°C
Insulation Resistance	≤.1μF is >30,000MΩ; >.1μF is >3000MΩ per μF

PART NUMBERING SYSTEM

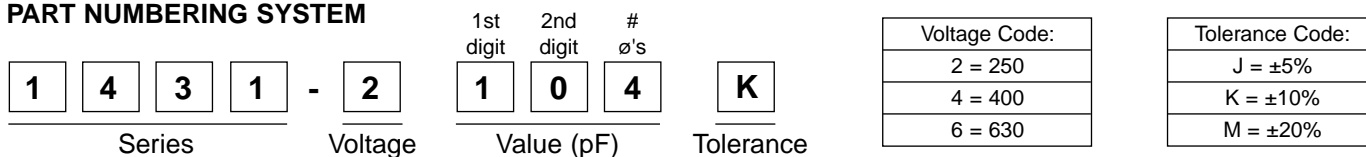

TYPICAL PERFORMANCE CHARACTERISTICS

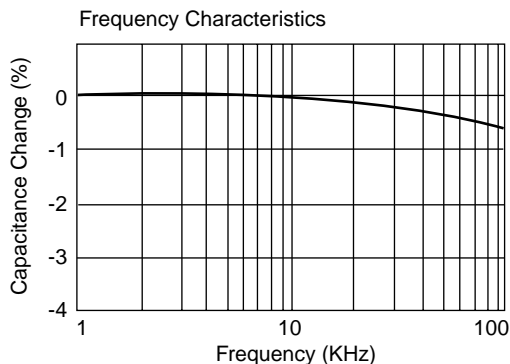
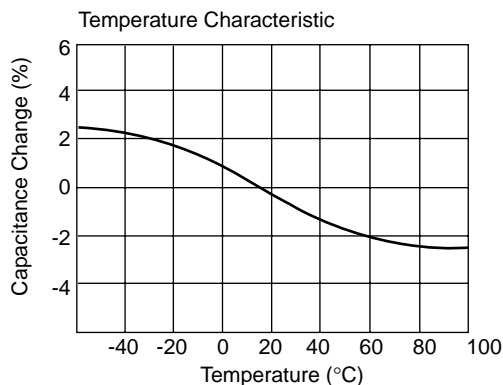

■ DIMENSIONS

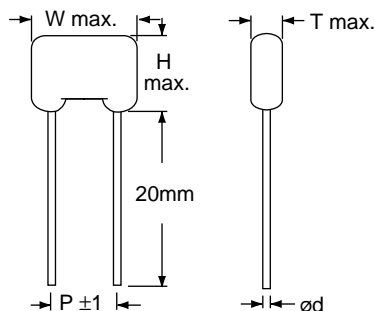

Value (μ F)	Working Voltage (WV); Dimensions (mm)								
	250			400			630		
	W x H x T	P	ϕ d	W x H x T	P	ϕ d	W x H x T	P	ϕ d
.001	10.5 x 9.5 x 6.0	7	0.6	14.0 x 8.5 x 5.5	10	0.6	14.0 x 8.5 x 6.0	10	0.6
.0015	10.5 x 9.5 x 6.0	7	0.6	14.0 x 9.5 x 6.0	10	0.6	14.0 x 9.0 x 6.5	10	0.6
.0022	10.5 x 9.5 x 6.0	7	0.6	14.0 x 9.5 x 6.0	10	0.6	14.0 x 10.0 x 6.5	10	0.6
.0033	10.5 x 9.5 x 6.0	7	0.6	14.0 x 9.5 x 6.0	10	0.6	14.0 x 12.0 x 6.5	10	0.6
.0047	10.5 x 9.5 x 6.0	7	0.6	14.0 x 9.5 x 6.0	10	0.6	14.0 x 13.0 x 7.5	10	0.6
.0068	14.0 x 9.5 x 6.0	10	0.6	14.0 x 10.0 x 6.5	10	0.6	19.0 x 12.5 x 7.5	15	0.8
.01	14.0 x 9.5 x 6.0	10	0.6	14.0 x 11.5 x 7.5	10	0.6	19.0 x 12.5 x 8.0	15	0.8
.015	14.0 x 10.0 x 6.5	10	0.6	14.0 x 13.0 x 8.0	10	0.6	19.0 x 14.5 x 8.5	15	0.8
.022	14.0 x 12.0 x 7.0	10	0.6	19.0 x 12.0 x 7.5	15	0.6	19.0 x 16.5 x 9.0	15	0.8
.033	19.0 x 11.5 x 6.5	15	0.6	19.0 x 14.0 x 8.5	15	0.6	26.0 x 18.0 x 11.0	22	0.8
.047	19.0 x 12.5 x 7.0	15	0.6	19.0 x 15.5 x 9.5	15	0.8	26.0 x 18.5 x 11.5	22	0.8
.068	19.0 x 13.0 x 7.5	15	0.8	26.0 x 16.5 x 9.0	22	0.8	31.0 x 19.0 x 11.0	27.5	0.8
.1	19.0 x 16.0 x 9.5	15	0.8	26.0 x 18.5 x 11.0	22	0.8	31.0 x 21.5 x 12.5	27.5	0.8
.15	26.0 x 17.5 x 10.0	21	0.8	26.0 x 21.0 x 14.0	22	0.8	32.0 x 25.5 x 15.5	27.5	0.8
.22	26.0 x 21.0 x 12.5	21	0.8	32.0 x 22.0 x 14.5	27.5	0.8	32.0 x 27.5 x 16.0	27.5	0.8
.33	32.0 x 22.5 x 13.0	27.5	0.8	32.0 x 26.0 x 18.5	27.5	0.8			
.47	32.0 x 26.0 x 15.5	27.5	0.8	32.0 x 28.0 x 20.5	27.5	0.8			

FEATURES

- Low dissipation factor
- High insulation resistance
- High stability of capacitance and DF versus temperature and frequency
- Self-healing properties
- Non-inductive construction
- Epoxy resin coating

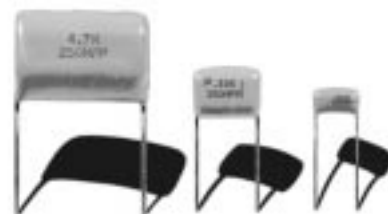

CHARACTERISTICS

Item	Characteristics
Operating Temperature Range	-40°C ~ +85°C
Capacitance Tolerance	±5%, ±10%, ±20%
Standard Working Voltage (WV)	100, 250, 400, 630
Dissipation Factor	0.1% max. (1KHz), 25°C
Insulation Resistance	≤.33μF is >30,000MΩ; >.33μF is >10,000MΩ per μF

PART NUMBERING SYSTEM

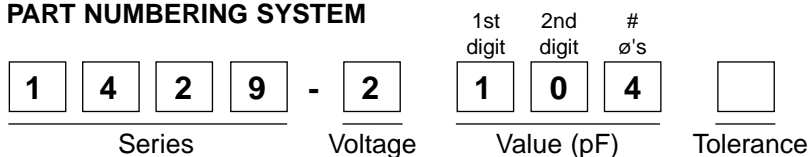

Voltage Code:
1 = 100
2 = 250
4 = 400
6 = 630

Tolerance Code:
J = ±5%
(blank) = ±10%
M = ±20%

TYPICAL PERFORMANCE CHARACTERISTICS: RATED VOLTAGE VS FREQUENCY

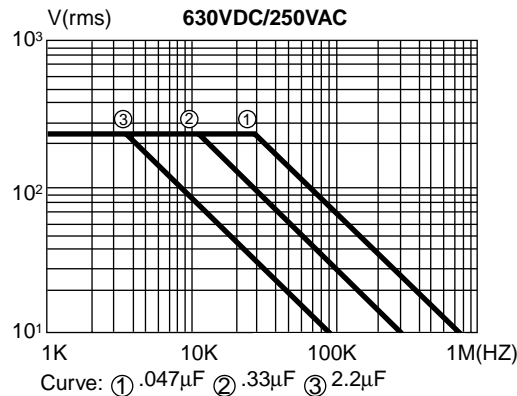
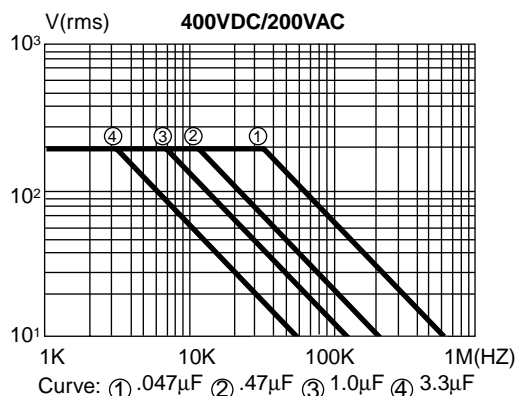
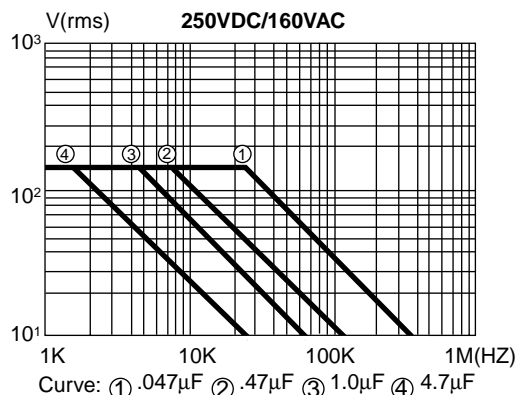
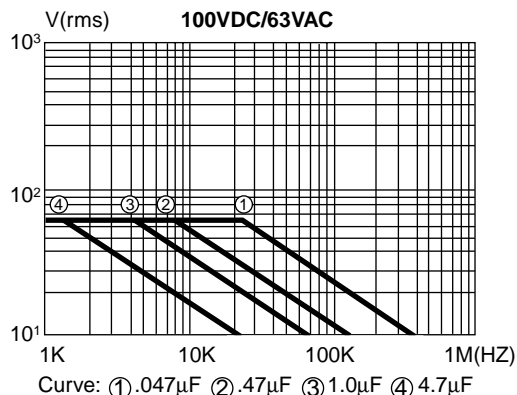

■ DIMENSIONS

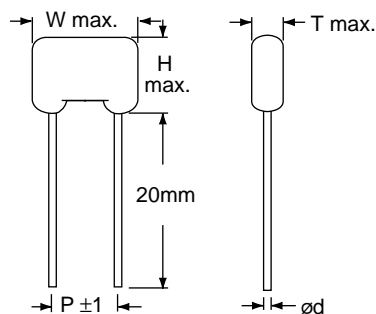

Value (μ F)	Working Voltage (WV); Dimensions (mm)											
	100			250			400			630		
	W x H x T	P	ϕ d	W x H x T	P	ϕ d	W x H x T	P	ϕ d	W x H x T	P	ϕ d
0.01	10.5 x 9.0 x 6.0	7.5	0.6	10.5 x 9.0 x 6.0	7.5	0.6	13.0 x 10.0 x 6.5	10	0.6	13.0 x 11.0 x 6.5	10	0.6
0.015	10.5 x 9.5 x 6.0	7.5	0.6	10.5 x 9.5 x 6.0	7.5	0.6	13.0 x 10.5 x 6.5	10	0.6	13.0 x 11.5 x 7.0	10	0.6
0.022	10.5 x 9.5 x 6.0	7.5	0.6	13.0 x 10.0 x 6.0	10	0.6	13.0 x 11.0 x 7.5	10	0.6	13.0 x 12.5 x 8.0	10	0.6
0.033	10.5 x 9.5 x 6.0	7.5	0.6	13.0 x 10.0 x 6.5	10	0.6	13.0 x 11.5 x 7.5	10	0.6	18.5 x 13.0 x 8.0	15	0.8
0.047	10.5 x 10.5 x 6.0	7.5	0.6	13.0 x 10.0 x 6.5	10	0.6	13.0 x 12.5 x 7.5	10	0.6	18.5 x 14.0 x 8.5	15	0.8
0.068	13.0 x 10.5 x 6.0	10	0.6	13.0 x 10.5 x 6.5	10	0.6	18.5 x 12.5 x 7.5	15	0.8	18.5 x 15.0 x 9.5	15	0.8
0.1	13.0 x 11.0 x 7.0	10	0.6	13.0 x 12.0 x 7.0	10	0.6	18.5 x 13.5 x 8.0	15	0.8	23.0 x 17.0 x 10.0	20	0.8
0.15	18.5 x 12.0 x 7.0	15	0.6	18.5 x 12.0 x 7.0	15	0.6	18.5 x 15.0 x 9.5	15	0.8	23.0 x 18.5 x 11.5	20	0.8
0.22	18.5 x 12.5 x 7.5	15	0.6	18.5 x 12.5 x 7.0	15	0.6	23.0 x 15.0 x 9.5	20	0.8	32.0 x 19.0 x 12.0	27.5	0.8
0.33	18.5 x 14.5 x 8.5	15	0.6	18.5 x 14.5 x 8.5	15	0.8	23.0 x 17.5 x 11.0	20	0.8	32.0 x 22.0 x 14.5	27.5	0.8
0.47	18.5 x 15.5 x 10.0	15	0.8	18.5 x 15.5 x 10.0	15	0.8	32.0 x 18.5 x 11.5	27.5	0.8	32.0 x 24.5 x 15.0	27.5	0.8
0.68	23.0 x 16.5 x 10.0	20	0.8	23.0 x 16.5 x 10.0	20	0.8	32.0 x 20.5 x 12.5	27.5	0.8	32.0 x 29.0 x 16.5	27.5	0.8
1.0	23.0 x 18.5 x 11.0	20	0.8	23.0 x 18.5 x 11.0	20	0.8	32.0 x 24.5 x 16.0	27.5	0.8	37.0 x 31.0 x 18.0	32.5	1.0
1.5	23.0 x 19.0 x 12.0	20	0.8	23.0 x 20.0 x 13.0	20	0.8	32.0 x 29.5 x 17.0	27.5	1.0			
2.2	32.0 x 22.0 x 12.5	27.5	0.8	32.0 x 22.0 x 13.5	27.5	0.8	37.0 x 31.0 x 18.0	32.5	1.0			
3.3	32.0 x 24.0 x 13.0	27.5	0.8	32.0 x 26.0 x 16.5	27.5	0.8						
4.7	32.0 x 25.0 x 14.5	27.5	1.0	37.0 x 27.0 x 18.0	32.5	1.0						
6.8	37.0 x 27.0 x 16.0	32.5	1.0	37.0 x 32.0 x 19.5	32.5	1.0						
10	37.0 x 32.0 x 18.5	32.5	1.0									

■ CHARACTERISTICS REFERENCE

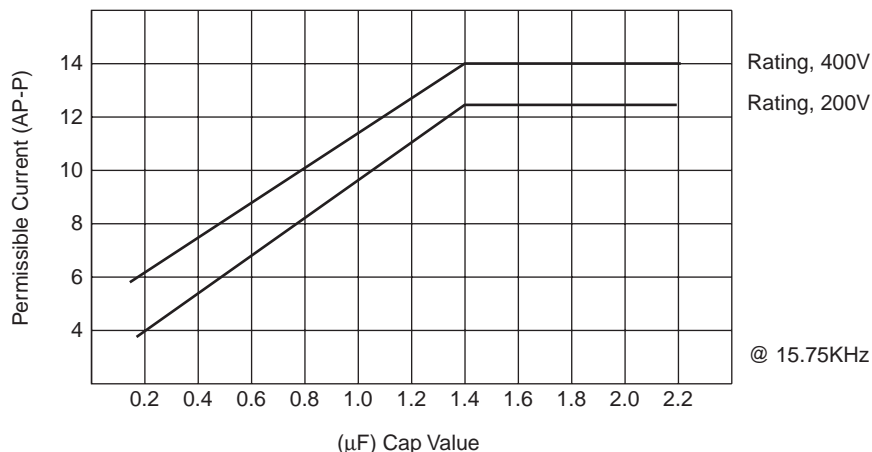

FEATURES

- Low temperature coefficient
- High stability and high insulation resistance
- Wide frequency range
- Ideal for high frequency circuits, and measuring instruments
- Electrodes and lead are spot welded to reduce series resistance
- Low dissipation factor



23PW Series



23PS Series

CHARACTERISTICS

Item	Characteristics
Operating Temperature Range	-40°C ~ +85°C
Capacitance Tolerance	±5% standard, other tolerances available upon request, ask for details
Standard Working Voltage (WV)	50, 125, 500
Insulation Resistance @ 25°C	100GΩ min.
Testing Voltage	300% of rated voltage for 1 minute
Dissipation Factor	0.1% maximum when measured @ 1KHz, 25°C for C>330pF
Quality Value (Q)	1,000 minimum when measured @ 1,000KHz, 25°C for C≤330pF
Load Life Test	@+85°C, 150% of WV for 1,000 hrs: C change is ≤2%; DF (or Q) is 0.15% max. (or 500min.); IR is 50GΩ min.
Lead Pull Test	Will withstand a pull of 1.0KG applied axially for 10 seconds
Lead Bend Test	Will sustain 2 cycles of attaching a load of 0.5KG to lead, bending 90° from the direction of lead egress, then 180° in opposite direction and back to the starting point.
Capacitance Drift	±0.5% maximum when cycled through the operating temperature range
Lead Material	Tinned copper
Humidity Test	@+40°C, 95% RH for 100 hrs: C change is ≤2%, DF is ≤0.15 or Q is ≥500, IR is ≥80GΩ

PART NUMBERING SYSTEM

2	3	P	W	1	1	0	
Voltage	Series	Type	Type	# ø's	1st digit	2nd digit	Tolerance

Voltage Code: 2 = 50 1 = 125 5 = 500	Tolerance Code: (blank) = ±5% K = ±10% M = ±20%
------------------------------------------------------	-----------------------------------------------------------------

PERFORMANCE CURVE

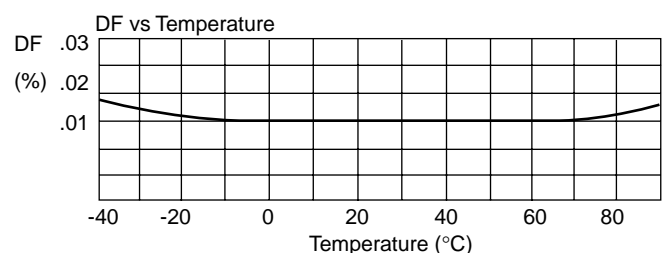
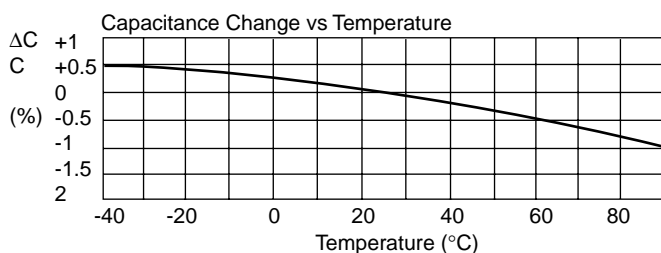

■ DIMENSIONS

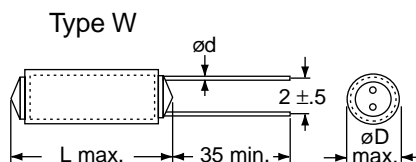
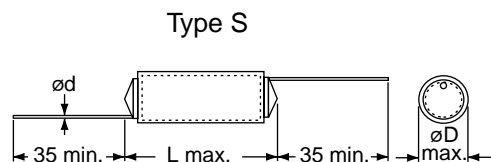

Value (pF)	Working Voltage (WV); Dimensions (mm)					
	50		125		500	
	$\varnothing D \times L$	$\varnothing d$	$\varnothing D \times L$	$\varnothing d$	$\varnothing D \times L$	$\varnothing d$
100	5.5 x 12	0.4	5.5 x 12	0.4	5.5 x 12	0.4
120	5.5 x 12	0.4	5.5 x 12	0.4	5.5 x 12	0.4
150	5.5 x 12	0.4	5.5 x 12	0.4	6 x 12	0.4
180	5.5 x 12	0.4	5.5 x 12	0.4	6 x 12	0.4
220	5.5 x 12	0.4	5.5 x 12	0.4	6 x 12	0.4
270	5.5 x 12	0.4	5.5 x 12	0.4	6 x 12	0.4
330	5.5 x 12	0.4	5.5 x 12	0.4	6.5 x 12	0.4
390	5.5 x 12	0.4	5.5 x 12	0.4	6.5 x 12	0.4
470	5.5 x 12	0.4	5.5 x 12	0.4	6.5 x 12	0.4
560	5.5 x 12	0.4	6 x 12	0.4	6.5 x 12	0.4
680	5.5 x 12	0.4	6.5 x 12	0.4	6.5 x 12	0.4
820	6 x 12	0.4	6.5 x 17	0.4	6.5 x 12	0.4
1000	6 x 12	0.4	6.5 x 17	0.4	7 x 17	0.4
1200	6 x 12	0.4	6.5 x 17	0.4	7.5 x 17	0.4
1500	6 x 12	0.4	6.5 x 17	0.4	7.5 x 21	0.4
1800	6 x 12	0.4	7 x 17	0.4	8 x 21	0.4
2200	6.5 x 12	0.4	7 x 17	0.4	8 x 22	0.4
2700	7 x 12	0.4	7 x 17	0.4	8.5 x 22	0.4
3300	7 x 12	0.4	7.5 x 17	0.4	9 x 24	0.5
3900	7.5 x 12	0.4	7.5 x 17	0.4	9.5 x 24	0.5
4700	8 x 12	0.4	8 x 19	0.4	10 x 24	0.5
5600	8.5 x 12	0.4	9 x 19	0.5	11 x 24	0.5
6800	9 x 12	0.4	9.5 x 19	0.5	11 x 24	0.5
8200	9.5 x 12	0.4	9.5 x 22	0.5	12 x 24	0.5
10000	10 x 12	0.4	10.5 x 22	0.5	13 x 24	0.5

FEATURES

- High moisture resistance
- Wide operating temperature range
- Leads are electrically welded to electrodes
- Conformally coated with flame retardant epoxy resin



CHARACTERISTICS

Item	Characteristics
Operating Temperature Range	-40°C ~ +85°C
Capacitance Tolerance	1~2%, 2%, ±5%, ±10%, ±20%
Standard Working Voltage (WV)	50, 100, 200, 400
Withstanding Voltage	Working Voltage x 2.5 (5 sec.)
Dissipation Factor	1.0% max. (1KHz)
Insulation Resistance	30,000MΩ
High Temperature Stability	Capacitance change +5% ~ -2% @ +85°C; Insulation resistance: 1,500MΩ min.
Low Temperature Stability	Capacitance change 0% ~ +5% @ -40°C; Insulation resistance: 1,500MΩ min.
Humidity Life	@+40°C, 90%~95%RH x WV for 250 ±4 hrs: C change is ±5% max.; DF change is 1.2% max.; IR is 9,000MΩ min.
Life Test	@+85°C, 1.4 x WV for 1,000 hrs: C change is ±8% max.; DF change is 1.1% max.; IR is 4,500MΩ min.
Lead Material	Solder plated annealed copper covered steel wire

PART NUMBERING SYSTEM

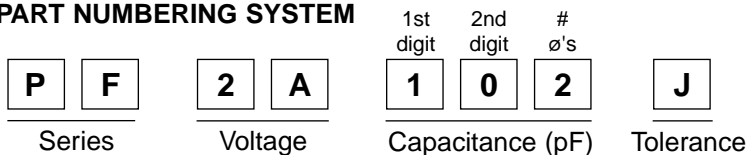

Voltage (WV) Code:
1H = 50
2A = 100
2D = 200
2G = 400

Tolerance Code:
F = 1~2%
G = 2%
J = ±5%
K = ±10%
M = ±20%

TEMPERATURE CHARACTERISTIC CHART

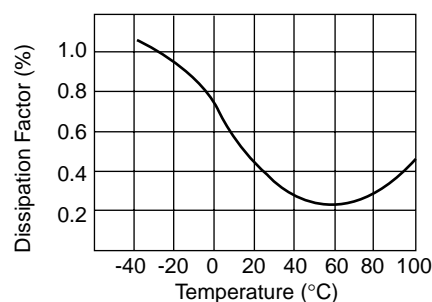
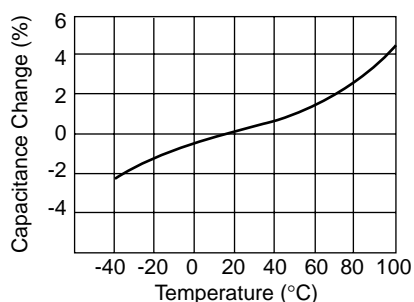

FREQUENCY CHARACTERISTIC CHART

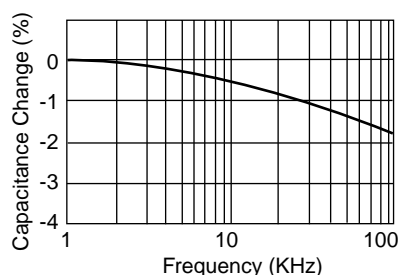

IMPEDANCE-FREQUENCY CHARACTERISTIC (Ω) CHART

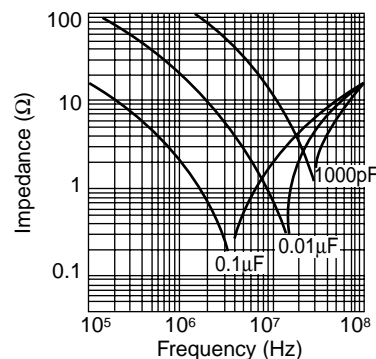

■ DIMENSIONS

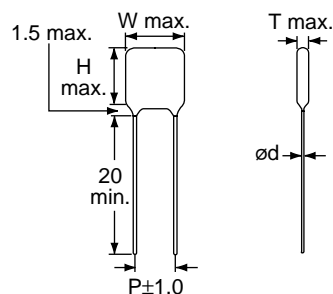

Value (µF)	Working Voltage (WV): 50 and 100; Dimensions (mm)		
	W x H x T	P	ød
0.001	6.0 x 10.5 x 3.0	3.5	0.5
0.0012	6.0 x 10.5 x 3.0	3.5	0.5
0.0015	6.0 x 10.5 x 3.0	3.5	0.5
0.0018	6.0 x 10.5 x 3.0	3.5	0.5
0.0022	6.0 x 10.5 x 3.0	3.5	0.5
0.0027	6.0 x 10.5 x 3.0	3.5	0.5
0.0033	6.0 x 10.5 x 3.0	3.5	0.5
0.0039	6.0 x 10.5 x 3.0	3.5	0.5
0.0047	6.0 x 10.5 x 3.0	3.5	0.5
0.0056	6.0 x 10.5 x 3.0	3.5	0.5
0.0068	6.0 x 10.5 x 3.5	3.5	0.5
0.0082	6.5 x 10.5 x 3.5	3.5	0.5
0.01	6.5 x 12.0 x 3.5	3.5	0.5
0.012	6.5 x 12.0 x 3.5	3.5	0.5
0.015	7.0 x 12.0 x 3.5	4.0	0.5
0.018	7.0 x 12.0 x 4.0	4.0	0.5
0.022	7.5 x 12.0 x 4.0	4.0	0.5
0.027	7.5 x 12.0 x 4.0	4.0	0.5
0.033	8.0 x 12.0 x 5.0	5.0	0.5
0.039	8.0 x 13.0 x 5.0	5.0	0.5
0.047	8.5 x 13.0 x 5.0	5.0	0.5
0.056	9.0 x 13.0 x 5.0	5.0	0.5
0.068	9.5 x 13.0 x 5.0	7.5	0.5
0.082	10.0 x 13.0 x 6.0	7.5	0.5
0.1	11.0 x 14.0 x 6.0	7.5	0.5
0.12	11.0 x 14.0 x 6.5	7.5	0.5
0.15	12.0 x 17.0 x 7.0	9.0	0.5
0.18	12.5 x 17.0 x 7.0	9.0	0.5
0.22	13.0 x 17.0 x 7.5	9.0	0.5
0.27	14.5 x 18.0 x 8.0	9.0	0.5
0.33	14.5 x 21.0 x 8.5	10.0	0.6
0.39	15.0 x 21.0 x 9.0	10.0	0.6
0.47	16.0 x 22.0 x 9.0	10.0	0.6

Value (µF)	Working Voltage (WV): 200; Dimensions (mm)		
	W x H x T	P	ød
0.001	6 x 12 x 3.5	3.5	0.5
0.0022	6 x 12 x 3.5	3.5	0.5
0.0047	6.5 x 12 x 3.5	3.5	0.5
0.01	8.5 x 13 x 4.5	5.0	0.5
0.015	9 x 13 x 6	5.0	0.5
0.022	10 x 13.5 x 6	5.0	0.5
0.047	14 x 15.5 x 7	7.5	0.5
0.05	14 x 15.5 x 7	7.5	0.5
0.1	17 x 20 x 9	10	0.5
0.15	18 x 21 x 9.5	12.5	0.5
0.2	19 x 21 x 11	12.5	0.5
0.22	19 x 21 x 11	12.5	0.5

Value (µF)	Working Voltage (WV): 400; Dimensions (mm)		
	W x H x T	P	ød
0.001	6 x 12 x 3.5	3.5	0.5
0.0022	6 x 12 x 3.5	3.5	0.5
0.0047	7 x 13 x 4	5.0	0.5
0.01	9 x 13 x 5	5.0	0.5
0.02	12 x 13.5 x 7	5.0	0.5
0.022	12 x 13.5 x 7	5.0	0.5
0.05	15 x 18 x 8	7.5	0.5
0.1	18 x 20 x 10	10	0.5

FEATURES

- High moisture resistance
- Wide operating temperature range
- Leads are electrically welded to electrodes
- Conformally coated with flame retardant epoxy resin



CHARACTERISTICS

Item	Characteristics
Operating Temperature Range	-40°C ~ +85°C
Capacitance Tolerance	±10%
Standard Working Voltage (WV)	100
Withstanding Voltage	Working Voltage x 2.5 (5 sec.)
Dissipation Factor	1.0% max. (1KHz)
Insulation Resistance	>30,000MΩ
High Temperature Stability	Capacitance change +5% ~ -2% @ +85°C; Insulation resistance: 1,500MΩ min.
Low Temperature Stability	Capacitance change 0% ~ +5% @ -40°C; Insulation resistance: 1,500MΩ min.
Humidity Life	@+40°C, 90%~95%RH x WV for 250 ±4 hrs: C change is ±5% max.; DF change is 1.2% max.; IR is 9,000MΩ min.
Life Test	@+85°C, 1/4 x WV for 1,000 hrs: C change is ±8% max.; DF change is 1.1% max.; IR is 4,500MΩ min.
Lead Material	Solder plated annealed copper covered steel wire

PART NUMBERING SYSTEM

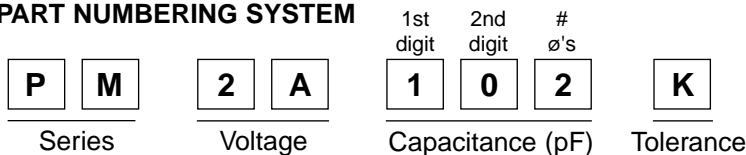

Voltage (WV) Code:	Tolerance Code:
2A = 100	K = ±10%

TEMPERATURE CHARACTERISTIC CHART

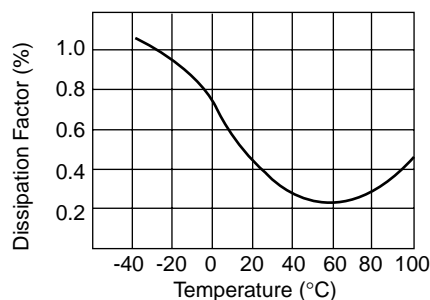
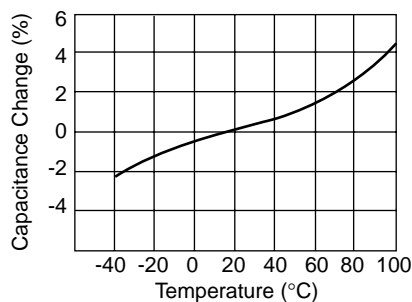

FREQUENCY CHARACTERISTIC CHART

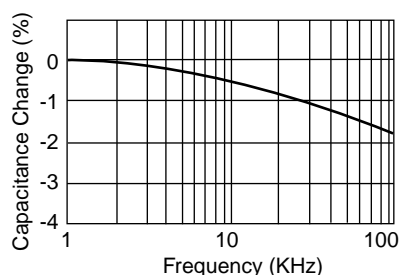

IMPEDANCE-FREQUENCY CHARACTERISTIC (Ω) CHART

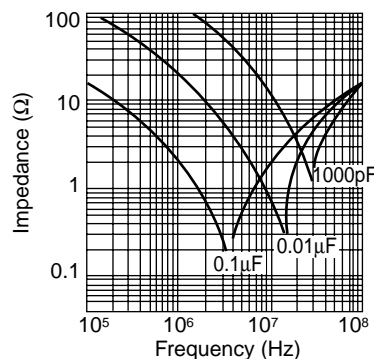

■ DIMENSIONS

Value (μF)	Working Voltage (WV): 100; Dimensions (mm)		
	W x H x T	P	$\varnothing d$
0.001	5.5 x 7.5 x 3.0	3.5	0.5
0.0012	5.5 x 7.5 x 3.0	3.5	0.5
0.0015	5.5 x 7.5 x 3.0	3.5	0.5
0.0018	5.5 x 7.5 x 3.0	3.5	0.5
0.0022	5.5 x 7.5 x 3.0	3.5	0.5
0.0027	6.0 x 7.5 x 3.0	3.5	0.5
0.0033	6.0 x 7.5 x 3.0	3.5	0.5
0.0039	6.0 x 7.5 x 3.0	3.5	0.5
0.0047	6.0 x 7.5 x 3.0	3.5	0.5
0.0056	6.0 x 7.5 x 3.0	3.5	0.5
0.0068	6.0 x 7.5 x 3.0	3.5	0.5
0.0082	6.0 x 7.5 x 3.5	3.5	0.5
0.01	6.0 x 7.5 x 3.5	3.5	0.5
0.012	6.0 x 7.5 x 3.5	3.5	0.5
0.015	6.0 x 8.5 x 3.5	3.5	0.5
0.018	6.0 x 9.0 x 3.5	3.5	0.5
0.022	6.5 x 9.0 x 3.5	3.5	0.5
0.027	6.5 x 9.0 x 4.0	3.5	0.5
0.033	6.5 x 9.0 x 4.0	3.5	0.5
0.039	7.5 x 9.0 x 4.0	5.0	0.5
0.047	7.5 x 9.5 x 4.0	5.0	0.5
0.056	7.5 x 10.5 x 4.5	5.0	0.5
0.068	8.0 x 10.5 x 5.0	5.0	0.5
0.082	8.0 x 11.0 x 5.0	5.0	0.5
0.1	8.5 x 11.5 x 6.0	5.0	0.5
0.12	9.0 x 12.5 x 6.0	5.0	0.5
0.15	9.5 x 12.5 x 6.5	5.0	0.5
0.18	10.5 x 12.5 x 7.0	7.5	0.5
0.22	11.5 x 13.0 x 7.0	7.5	0.5
0.47	13.0 x 15.5 x 8.0	7.5	0.5

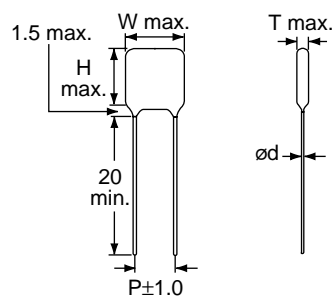

FEATURES

- High stability and reliability
- Low ESR
- Non-inductive construction minimizes dissipation factor
- Epoxy resin coating



CHARACTERISTICS

Item	Characteristics
Operating Temperature Range	-40°C ~ +85°C
Capacitance Tolerance	±5%, ±10%, ±20%
Standard Working Voltage (WV)	50, 100, 200
Dissipation Factor	0.8% max. (1KHz), 25°C
Insulation Resistance	≤0.1μF is >20,000MΩ; >0.1μF is >2,000MΩ per μF

PART NUMBERING SYSTEM

1	4	3	2	2	1	0	2	
Series				Voltage	Capacitance (pF)			Tolerance

1st digit	2nd digit	# ø's
1	0	2

Voltage (WV) Code:	Tolerance Code:
5 = 50	J = ±5%
1 = 100	(blank) = ±10%
2 = 200	M = ±20%

DIMENSIONS

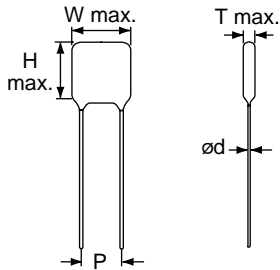

Value (μF)	Working Voltage (WV); Dimensions (mm)					
	50 and 100			200		
	W x H x T	P	ød	W x H x T	P	ød
0.001	10.5 x 9.0 x 5.5	7±1	0.6	10.5 x 9.0 x 6.0	7±1	0.6
0.0015	10.5 x 9.0 x 5.5	7±1	0.6	10.5 x 9.0 x 6.0	7±1	0.6
0.0022	10.5 x 9.0 x 5.5	7±1	0.6	10.5 x 9.0 x 6.0	7±1	0.6
0.0033	10.5 x 9.0 x 5.5	7±1	0.6	10.5 x 9.0 x 6.0	7±1	0.6
0.0047	10.5 x 9.0 x 6.0	7±1	0.6	10.5 x 9.0 x 6.0	7±1	0.6
0.0068	10.5 x 9.0 x 6.0	7±1	0.6	10.5 x 9.0 x 6.0	7±1	0.6
0.01	10.5 x 9.0 x 6.0	7±1	0.6	10.5 x 9.0 x 6.0	7±1	0.6
0.015	10.5 x 9.0 x 6.0	7±1	0.6	13.5 x 10.0 x 6.0	10±1.5	0.6
0.022	11.0 x 9.0 x 6.0	7±1	0.6	13.5 x 11.0 x 6.0	10±1.5	0.6
0.033	11.0 x 10.0 x 6.0	7±1	0.6	13.5 x 13.0 x 7.0	10±1.5	0.6
0.047	13.5 x 11.0 x 6.5	10±1.5	0.6	19.0 x 14.0 x 8.0	15±1.5	0.6
0.068	13.5 x 12.5 x 7.0	10±1.5	0.6	19.0 x 16.0 x 9.0	15±1.5	0.8
0.1	14.0 x 13.0 x 8.0	10±1.5	0.6	19.0 x 17.0 x 9.5	15±1.5	0.8
0.15	19.0 x 14.0 x 8.0	15±1.5	0.8	19.0 x 18.0 x 10.0	15±1.5	0.8
0.22	19.0 x 16.0 x 8.5	15±1.5	0.8	26.0 x 21.0 x 10.5	22±1.5	0.8
0.33	19.0 x 18.0 x 10.0	15±1.5	0.8	26.0 x 22.0 x 11.5	22±1.5	0.8
0.47	26.0 x 21.0 x 12.5	22±1.5	0.8	31.0 x 24.0 x 13.0	27.5±1.5	0.8



Ceramic Axial-Lead Capacitors (Small Body Style) CA10 Series



CHARACTERISTICS

Item	Characteristics		
	NPO	X7R	Z5U
Operating Temperature Range	-55°C ~ +125°C	-55°C ~ +125°C	-25°C ~ +85°C
Working Voltage (WVDC)	50 (other voltages available upon special order, ask for details)		
Capacitance Range	10pF ~ 1200pF	330pF ~ 27000pF	1000pF ~ 470,000pF
Temperature Characteristics	>20pF is 0 ±30ppm/°C; ≤20pF is 0 +120/-40ppm/°C	ΔC ±15% maximum over -55°C ~ +125°C	ΔC +22/-55% maximum over +10°C ~ +85°C
Dissipation Factor (Tan δ)	≥50pF is ≤0.001; <50pF is ≥1.5(150/C + 7) × 10 ⁴	≤0.025	≤0.030
Measuring Conditions for Capacitance and DF	>1000pF is 1KHz, 1Vrms; ≤1000pF is 1MHz, 1Vrms	1KHz, 1Vrms	1KHz, 0.3Vrms
Capacitance Aging	0	1.5% per decade hour	5% per decade hour
Insulation Resistance (IR)	After 60 seconds charging at WV, 25°C: ≥100GΩ or ≥1,000MΩ per μF, whichever is less		
Solderability Test	235 ±5°C, immersion 2 ±0.5 seconds, 1.5mm ~ 2.0mm depth. At least 95% of leads should be well tinned		
Resistance to Soldering Heat Test	No visible damage. NPO is ≤ ±0.5% or ±0.5pF; X7R is ≤+10/-5%; Z5U is ≤+20/-10%. Immersion in solder bath at 260 ±5°C for 10 ±1 seconds. Recovery for 24 ±2 hours.		
Rapid Change of Temp. Test	No visible damage. NPO and X7R at -55°C ~ +125°C; Z5U at -25°C ~ +85°C. Recovery for 24 ±2 hours.		
Life Test	No visible damage. NPO ΔC/C is ≤2% or ±2pF; X7R ΔC/C is ≤+10%; Z5U ΔC/C is ≤+20%. DF is ≤1.5 x initial requirement. IR is ≥0.25 x initial requirement. 1,000 hours at minimum temperature with 1.5 WV applied. Recovery for 24 ±2 hours		
Vibration Test	No visible damage. 5 cycles for 30 min. each: 10Hz ~ 2000KHz, apm. 0.75mm or 98m/sec. Total duration is 6 hours.		
Robustness of Termination Test	No visible damage. Visual inspection test: VAL is 10N, VB is 5N.		

PART NUMBERING SYSTEM

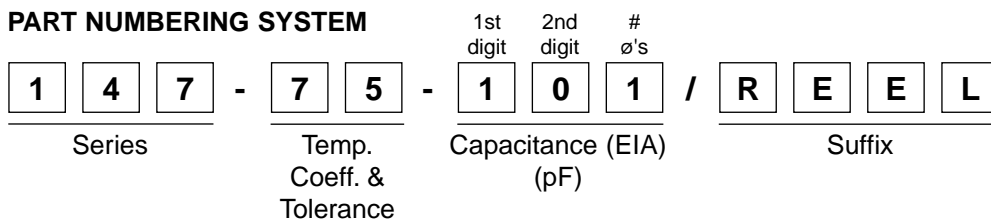

Temp. Coeff. & Tol. Code:
75 = NPO, 5%
71 = X7R, 10%
72 = Z5U, 20%

DIMENSIONS (mm)

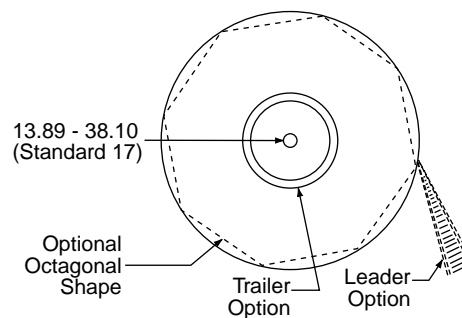
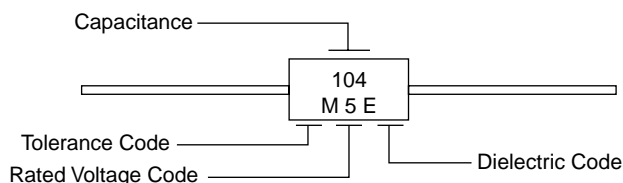
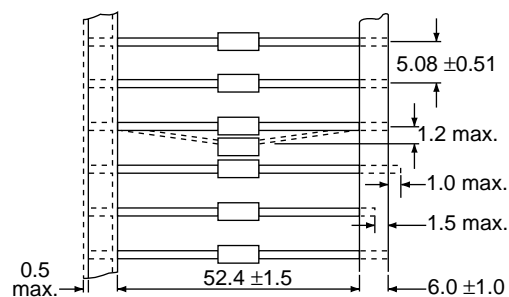
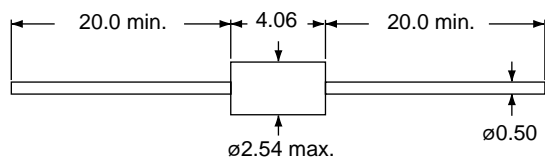

FEATURES

- Linear temperature coefficient of capacitance
- High stability of capacitance
- Low loss across a wide frequency range



CHARACTERISTICS

Item	Characteristics
Operating Temperature Range	-25°C ~ +85°C
Capacitance Tolerance (min.)	Within the tolerance at 1MHz, 1~3Vrms, 25°C
Working Voltage (WVDC)	50WV or 500WV
Insulation Resistance	10,000MΩ min.
Test Voltage	3 x WVDC
Life Test	At 2 x WVDC @85°C for 1000 hours @ 85°C, capacitors shall meet the following: the capacitance change for ≤30pF will be ≤±5% or ≤0.3pF; for >30pF the capacitance change will be ≤±3%. For ≤30pF Q ≥ 275 = 5/3C; for >30pF Q ≥ 350
Humidity Test	At exposure in the ambient temperature of 40°C, and at 95% RH for 500 hours the capacitors shall meet the following after 24 hours exposure at room temperature: the capacitance change for ≤30pF will be ≤±5% or ≤0.3pF; for >30pF the capacitance change will be ≤±5%. For ≤30pF Q ≥ 275 = 5/3C; for >30pF Q ≥ 350

PART NUMBERING SYSTEM

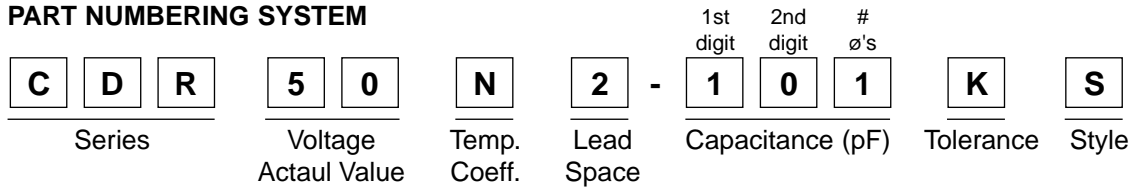

Temp. Coeff.	Code
NPO	N
N750	E
SL	S

Lead Space	Code
2.5mm	2
5.0mm	5

Tolerance	Code	Tolerance	Code
±0.25pF	C	±20%	M
±5%	J	±0.5pF	D
±10%	K	+80/-20%	Z

Style	Code
Straight	S
Formed	F

DIMENSIONS (mm), CAPACITANCE RANGES (pF), TYPICAL TEMPERATURE CHARACTERISTICS

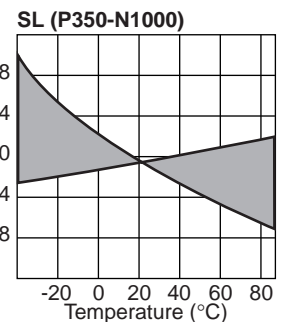
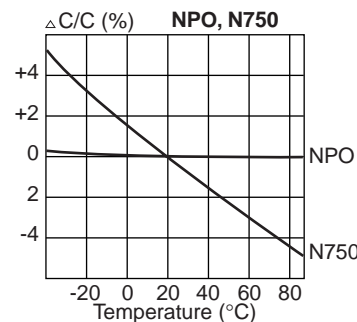
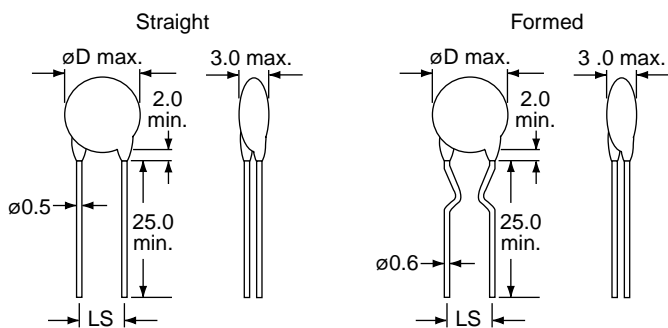

Dimensions		Working Voltage (WV); Temperature Coefficient; Capacitance Range (pF)					
		50			500		
øD (mm)	LS (mm)	NPO	N750	SL	NPO	N750	SL
5	2.5/5.0	1 ~ 47	22 ~ 47	50 ~ 150	1-33	---	39 ~ 100
6	2.5/5.0	56 ~ 68	---	180 ~ 220	36	18 ~ 33	120 ~ 150
7.5	2.5/5.0	82 ~ 100	---	250 ~ 330	39 ~ 68	39 ~ 68	180 ~ 220
8.5	2.5/5.0	120 ~ 150	---	390 ~ 470	---	---	270 ~ 300
9.5	5.0	180 ~ 200	---	500 ~ 680	---	---	300 ~ 390
10.5	5.0	220 ~ 270	---	820	---	---	400 ~ 470
12.5	5.0	300 ~ 330	---	---	---	---	560



FEATURES

- Linear temperature coefficient of capacitance
- High stability of capacitance
- Low loss across a wide frequency range



CHARACTERISTICS

Item	Characteristics
Operating Temperature Range	-25°C ~ +85°C
Capacitance Tolerance (min.)	Within the tolerance at 1MHz, 1~3Vrms, 25°C
Working Voltage (WVDC)	1KWV, 2KWV, or 3KWV
Insulation Resistance	10,000MΩ min. or 200MΩ x μF whichever is the smaller
Test Voltage	3 x WVDC
Life Test	At 2 x WVDC @85°C for 1000 hours @ 85°C, capacitors shall meet the following: the capacitance change for ≤30pF will be ≤±5% or ≤0.5pF; for >30pF the capacitance change will be ≤±5%. For ≤30pF Q ≥ 27.5 = 5/3C; for >30pF Q ≥ 350
Humidity Test	At exposure in the ambient temperature of 40°C, and at 95% RH for 500 hours the capacitors shall meet the following after 24 hours exposure at room temperature: the capacitance change for ≤30pF will be ≤±5% or ≤0.5pF; for >30pF the capacitance change will be ≤±5%. For ≤30pF Q ≥ 27.5 = 5/3C; for >30pF Q ≥ 350

PART NUMBERING SYSTEM

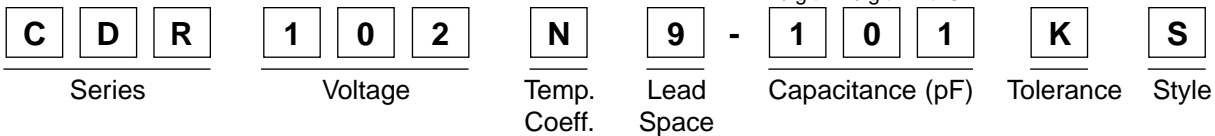

Voltage	Code
1K	102
2K	202
3K	302

Temp. Coeff.	Code
NPO	N
SL	S

Lead Space	Code
6.35mm	6
9.52mm	9

Tolerance	Code
±0.25pF	C
±5%	J
±10%	K

Tolerance	Code
±20%	M
±0.5pF	D
+80/-20%	Z

Style	Code
Straight	S
Formed	F

DIMENSIONS (mm), CAPACITANCE RANGES (pF), TYPICAL TEMPERATURE CHARACTERISTICS

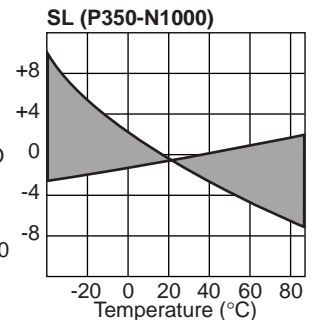
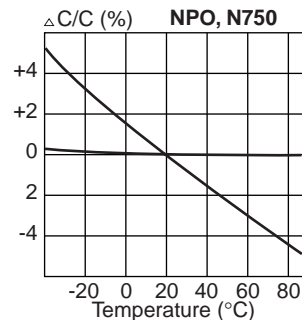
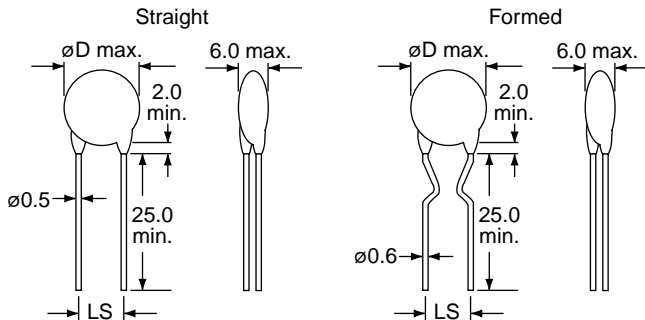

Dimensions		Working Voltage (WV); Temperature Coefficient; Capacitance Range (pF)					
		1K		2K		3K	
øD (mm)	LS (mm)	NPO	SL	NPO	SL	NPO	SL
6.5	6.35	1 ~ 25	30 ~ 80	---	---	---	---
7	6.35	---	---	1 ~ 10	20 ~ 33	---	---
8.5	6.35	26 ~ 40	81 ~ 40	11 ~ 18	34 ~ 68	---	---
9.5	6.35	41 ~ 70	141 ~ 240	---	---	---	---
10	6.35	---	---	---	69 ~ 100	1 ~ 16	15 ~ 56
11	6.35	---	---	19 ~ 39	110 ~ 140	18 ~ 24	62 ~ 82
13	9.52	71 ~ 120	241 ~ 400	40 ~ 62	150 ~ 230	---	---
15	9.52	---	---	---	---	---	---
16	9.52	---	---	63 ~ 82	240 ~ 310	27 ~ 51	91 ~ 160



■ DIMENSIONS (mm), CAPACITANCE RANGES (pF)

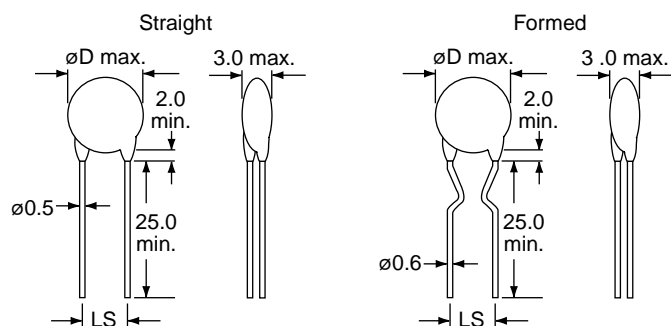

Dimensions		Working Voltage (WV); Temperature Coefficient; Capacitance Range (pF)					
		50 and 100			500		
ϕD (mm)	LS (mm)	Y5P	Z5U	Z5V	Y5P	Z5U	
5	2.5/5.0	200 ~ 2200	2000 ~ 5000	1000 ~ 10000	150 ~ 270	2000 ~ 2200	
6	2.5/5.0	2700 ~ 3000	6800 ~ 8200	---	390 ~ 1200	3700 ~ 3900	
7.5	2.5/5.0	3300 ~ 3900	10000	20000 ~ 22000	1500 ~ 2000	---	
8.5	2.5/5.0	4700 ~ 5600	---	---	2200 ~ 2700	4700 ~ 5000	
9.5	5.0	6800 ~ 8200	---	---	3000 ~ 3300	6800 ~ 8200	
10.5	5.0	10000	20000 ~ 22000	---	3900	10000	
14.5	9.5	---	---	33000 ~ 100,000	---	---	

■ TYPICAL TEMPERATURE CHARACTERISTICS

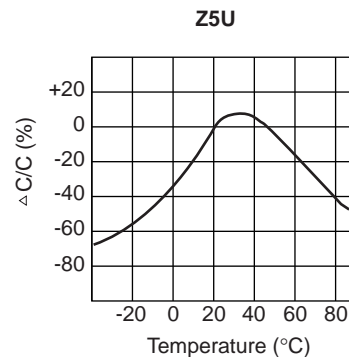
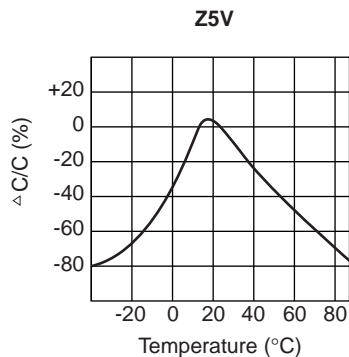
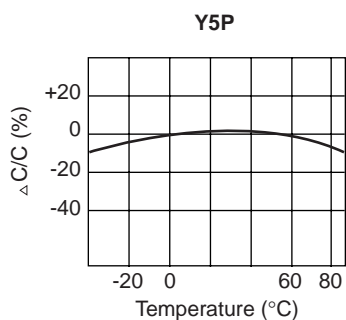

FEATURES

- Large capacitance in small sizes
- Non linear temperature coefficient of capacitance.



CHARACTERISTICS

Item	Characteristics
Operating Temperature Range	-25°C ~ +85°C
Capacitance Tolerance (min.)	Within the tolerance at 1MHz, 1~3Vrms, 25°C
Working Voltage (WVDC)	1KWV, 2KWV, 3KWV
Insulation Resistance	10,000MΩ min. or 200MΩμF, whichever is less
Test Voltage	2.5 x WVDC
Life Test	At 2 x WVDC @85°C for 1000 hours @ 85°C, capacitors shall meet the following: the capacitance change for Y5P will be ±10%; Z5U will be ±20%; Z5V will be ±30%; the dissipation factor for Y5P and Z5U will be 50x10 ⁻³ ; Z5V will be 75x10 ⁻³ .
Humidity Test	At exposure in the ambient temperature of 40°C, and at 95% RH for 500 hours: the capacitance change for Y5P will be ±10%; Z5U will be ±20%; Z5V will be ±30%; the dissipation factor for Y5P and Z5U will be 50x10 ⁻³ ; Z5V will be 75x10 ⁻³ .

PART NUMBERING SYSTEM

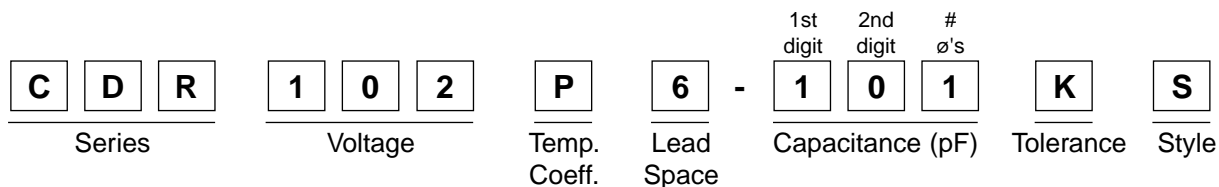

Voltage	Code
1K	102
2K	202
3K	302

Temp. Coeff.	Code
Y5P	P
Z5U	Z
Z5V	Q

Lead Space	Code
6.35mm	6
9.52mm	9

Tolerance	Code
±0.25pF	C
±5%	J
±10%	K

Tolerance	Code
±20%	M
±0.5pF	D
+80/-20%	Z

Style	Code
Straight	S
Formed	F

TEMPERATURE COEFFICIENT CHARACTERISTICS

Temperature Coefficient	Y5P	Z5U	Z5V
Operating Temp. Range	-25°C ~ +85°C	+10°C ~ +85°C	+10°C ~ +85°C
Capacitance Change	±10%	+20, -55%	+30, -80°

■ DIMENSIONS (mm), CAPACITANCE RANGES (pF)

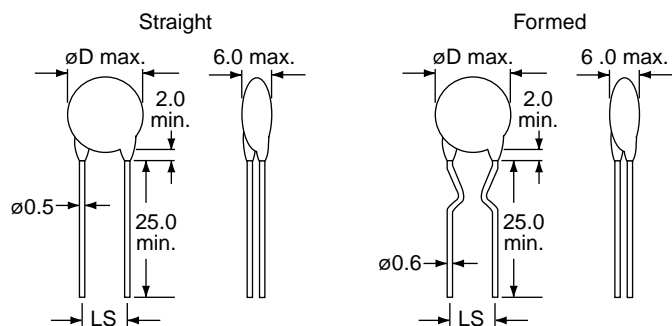

Dimensions		Working Voltage (WV); Temperature Coefficient; Capacitance Range (pF)								
		1K			2K			3K		
ϕD (mm)	LS (mm)	Y5P	Z5U	Z5V	Y5P	Z5U	Z5V	Y5P	Z5U	Z5V
6.5	6.35	300 ~ 1000	1000 ~ 2000	2000	---	---	---	---	---	---
7	6.35	---	---	---	100 ~ 680	---	1000	100 ~ 300	---	---
8	6.35	---	---	---	---	---	---	360 ~ 470	1000	---
8.5	6.35	1200 ~ 1500	5000	5000	820 ~ 1000	10000	1200 ~ 1800	---	---	---
9	6.35	---	---	---	---	---	---	560 ~ 680	---	---
9.5	6.35	2000 ~ 2200	---	---	---	---	---	---	---	---
10	6.35	---	---	---	1200 ~ 1500	---	2200 ~ 3300	820 ~ 1000	---	---
11	6.35	2700 ~ 3300	---	10000	---	1200 ~ 2200	3600 ~ 4700	---	---	2200 ~ 3300
12	6.35	---	---	---	1800 ~ 2200	---	---	1200 ~ 1500	1200 ~ 2200	3600 ~ 3900
13	6.35	---	10000	---	---	2700 ~ 3300	---	---	---	---
14	9.52	3900	---	---	---	---	---	1800 ~ 2200	2700 ~ 3600	---
15	9.52	5000	---	20000	3900 ~ 4700	3900 ~ 4700	---	---	---	4700 ~ 5600
16	9.52	---	---	---	---	---	10000	2700 ~ 3300	3900 ~ 4700	---
17	9.52	---	20000	---	---	---	---	---	---	---
19	9.52	10000	---	---	---	---	---	---	---	---

■ TYPICAL TEMPERATURE CHARACTERISTICS

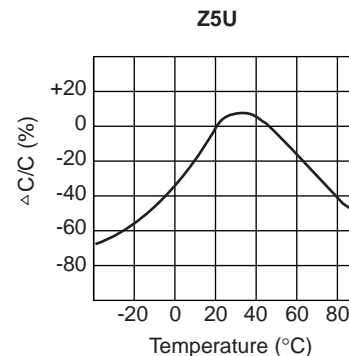
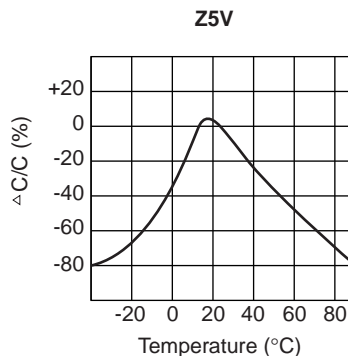
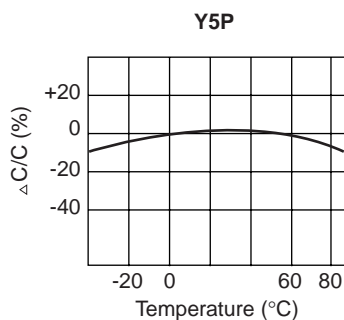

■ FEATURES

- Stable capacitance change over the specified temperature
- Low loss at wide range of frequency
- Cost saving by replacing film capacitors
- Ultra large capacitance in small sizes



■ CHARACTERISTICS

Item	Characteristics
Operating Temperature Range	-25°C ~ +85°C
Capacitance Tolerance (min.)	Within the tolerance at 1KHz, 0.1Vrms, 25°C
Working Voltage (WVDC)	12WV, 16WV, 25WV, 50WV, or 63WV
Insulation Resistance	12WV/16WV: 100MΩ or 10MΩ x μ whichever is less; 25WV/50WV: 1,000MΩ or 20MΩ x μF, whichever is less
Test Voltage	2.5 x WVDC
Life Test	At 2 x WVDC @85°C for 1000 hours @ 85°C, capacitors shall meet the following: the capacitance change for Y5P will be ±10%; Y5U will be ±20%; Y5V will be ±30%; the dissipation factor for Y5P and Y5U will be 5%; Y5V will be 7.5%.
Humidity Test	At exposure in the ambient temperature of 40°C, and at 95% RH for 500 hours: the capacitance change for Y5P will be ±10%; Y5U will be ±20%; Y5V will be ±30%; the dissipation factor for Y5P and Y5U will be 7.5%; Y5V will be 7.5%.

■ PART NUMBERING SYSTEM

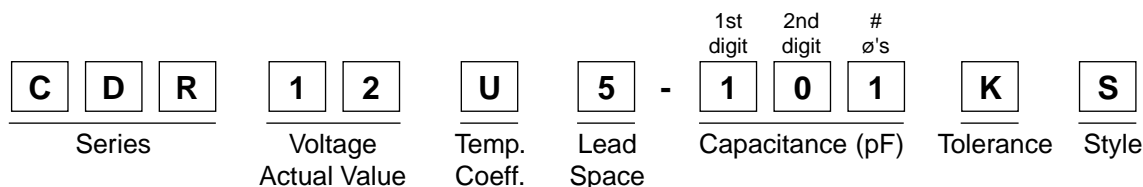

Temp. Coeff.	Code
Y5P	P
Y5U	U
Y5V	V

Lead Space	Code
5.0mm	5
6.3mm	6

Tolerance	Code
±0.25pF	C
±5%	J
±10%	K

Tolerance	Code
±20%	M
±0.5pF	D
+80/-20%	Z

Style	Code
Straight	S
Formed	F

■ TEMPERATURE COEFFICIENT CHARACTERISTICS

Temperature Coefficient	Y5P	Y5U	Y5V
Operating Temp. Range	-25°C ~ +85°C	-25°C ~ +85°C	-5°C ~ +85°C
Capacitance Change	±10%	+20, -55%	+30, -80°

■ DIMENSIONS (mm), CAPACITANCE RANGES (pF)

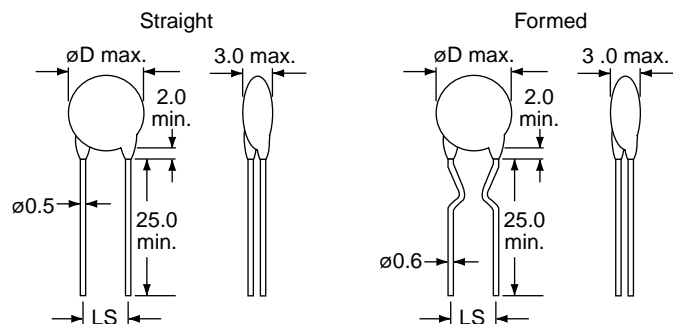

Dimensions		Working Voltage (WV); Temperature Coefficient; Capacitance Range (pF)								
		12V			25V			50V		
ϕD (mm)	LS (mm)	Y5P	Y5U	Y5V	Y5P	Y5U	Y5V	Y5P	Y5U	Y5V
5	5.0	.01	.01 ~ .022	.01 ~ .022	---	.01 ~ .022	---	---	.01	---
5.5	5.0	.022	.033 ~ .047	.033 ~ .047	.01	---	.033 ~ .047	.01	.022	---
6	5.0	.033	---	.1	---	---	---	---	---	---
6.5	5.0	---	---	---	---	.047	---	---	---	.047
7	5.0	.047	.1	---	.022	---	.1	---	---	---
8.5	5.0	---	---	---	.033	.1	---	.022	.47	---
9.5	5.0	---	.22	.22	.047	---	.22	.033	.1	.1
12	5.0	.1	---	---	---	.22	---	.047	---	---
13.5	5.0	---	---	---	---	---	---	---	---	---
15	6.3	---	.47	.47	.1	---	---	.1	---	---

■ TYPICAL TEMPERATURE CHARACTERISTICS

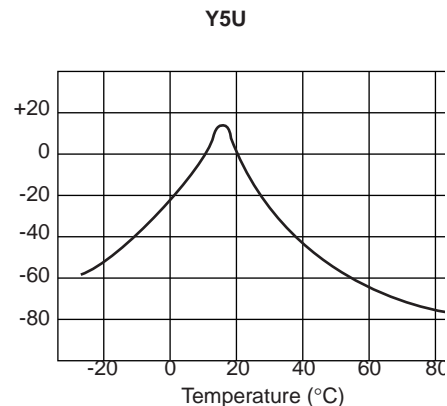
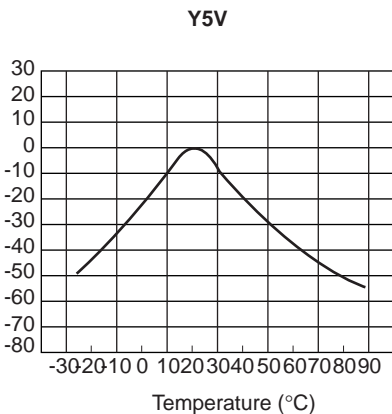
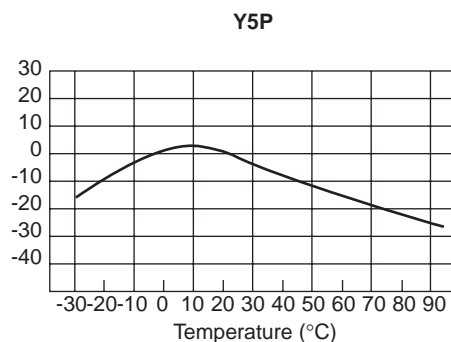

■ DIMENSIONS (mm)

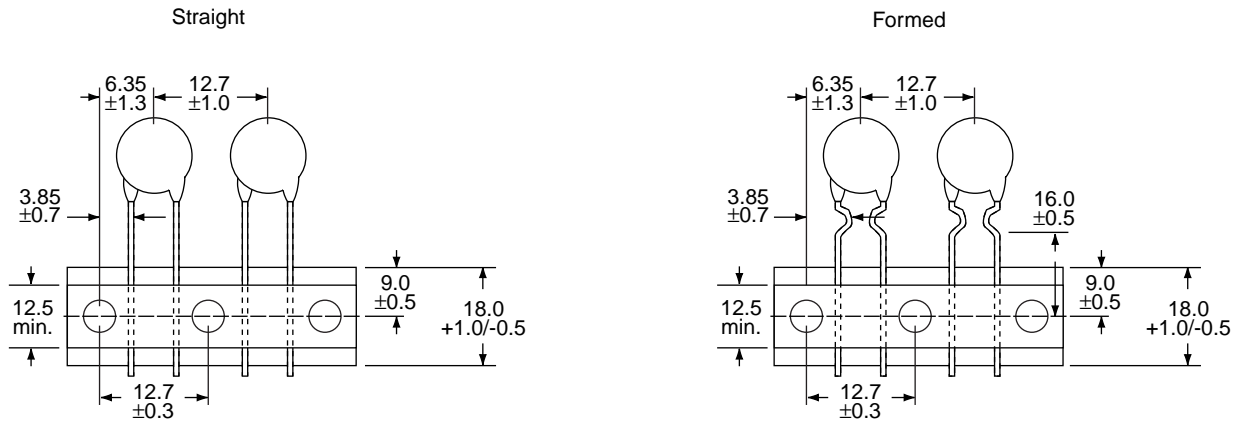

■ TAPE AND REEL SPECIFICATIONS AND DIMENSIONS (mm)

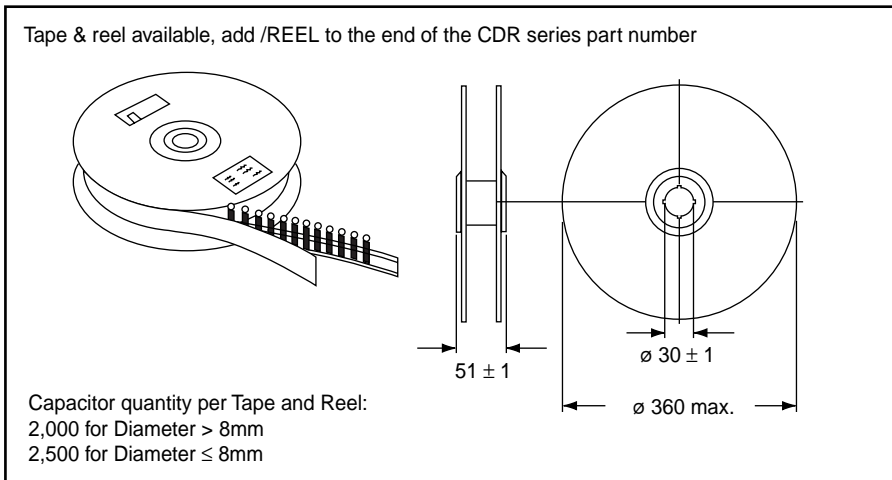

■ AMMO PACK SPECIFICATIONS AND DIMENSIONS (mm)

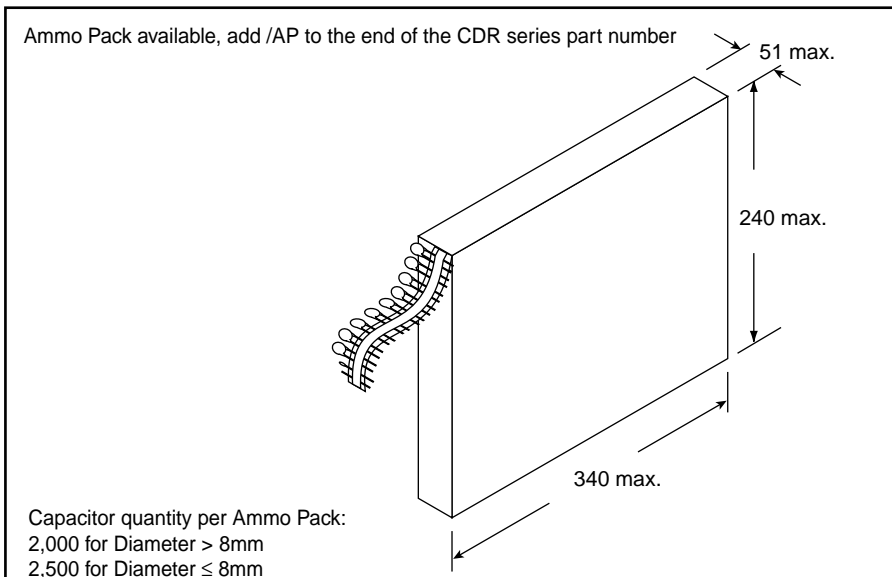

FEATURES

- Ideal for across the line applications
- Compact size
- Cost effective product
- Safety standards recognized for AC applications

CHARACTERISTICS

Item	Characteristics
Operating Temperature Range	-25°C ~ +85°C
Capacitance Tolerance (min.)	±10%, ±20, +80/-20%
Working Voltage (VAC)	400VAC
Insulation Resistance	10,000MΩ @ 500VDC for 1 minute @ 25°C
Dielectric Strength	2600VAC for 60 seconds
Temperature Coefficient	Y5P: ±10%; Y5V: +30~-80%
Dissipation factor	Y5P: 2.5% max. at 25°C and 1KHz, 1 ±0.2Vrms; Y5V: 5.0% max. at 25°C and 1KHz, 1 ±0.2Vrms

PART NUMBERING SYSTEM

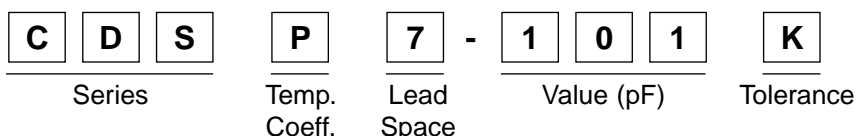

Temp. Coeff.; Code		Lead Space.; Code		Tolerance; Code		
Y5P	Y5V	7.5 ±1	9.5 ±1	±10%	±20%	+80/-20%
P	V	7	9	K	M	Z

DIMENSIONS (mm), CAPACITANCE RANGES (pF)

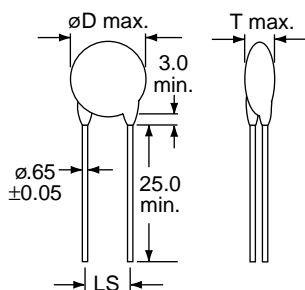

Value (pF)	Y5P			Value (pF)	Y5V		
	Dimensions (mm)				Dimensions (mm)		
	øD	LS	T		øD	LS	T
100	8	7.5 ±1	6	1000	10	7.5 ±1	6
150	8	7.5 ±1	6	1500	10	7.5 ±1	6
220	8	7.5 ±1	6	2200	12	7.5 ±1	6
330	8	7.5 ±1	6	3300	14	9.5 ±1	6
470	8	7.5 ±1	6	3900	16	9.5 ±1	6
560	10	7.5 ±1	6	4700	16	9.5 ±1	6
680	10	7.5 ±1	6	6800	16	9.5 ±1	6
1000	12	7.5 ±1	6	8200	16	9.5 ±1	6
				10000	18	9.5 ±1	6



FEATURES

- Epoxy-dipped multilayer ceramic capacitors are built with superior moisture and shock resistant epoxy coating
- Can be supplied in bulk or tape and reel package for automatic insertion in printed circuit boards
- Have wide application in computer, data processing, telecommunications, industrial control, and instrumentation equipment, etc...



CHARACTERISTICS

Item	Characteristics		
	NPO	X7R	Z5U
Temperature			
Temperature Characteristics	0 ±30ppm/°C	ΔC: ±15% max. over temp. range	ΔC: +22/-56% max. over temp. range
Operating Temperature	-55°C ~ +125°C	-55°C ~ +125°C	-30°C ~ +85°C
Working Voltage (WV)	50 and 100	50 and 100	50 and 100
Dissipation Factor (DF) @25°C	0.15% max. @1Vrms: 1MHz for ≤1,000pF; 1KHz for >1,000pF	2.5% max. @1Vrms, 1KHz	2.5% max. @0.5Vrms, 1KHz
Insulation Resistance @25°C With WV applied for 60 seconds	100,000MΩ or 1,000MΩ per μF; whichever is less	100,000MΩ or 1,000MΩ per μF; whichever is less	10,000MΩ or 100MΩ per μF; whichever is less
Dielectric Withstanding Voltage, 25°C	<0.5μF is 250%; ≥0.5μF is 200% of WV for 5 seconds with charge and discharge current limited to 50mA max.		
Life Test	@125°C, 250% of WV for 1,000 hrs.	@125°C, 250% of WV for 1,000 hrs.	@85°C, 150% of WV for 240 hrs.
Aging Rate (per decade hour)	None	Typical 2.5%	Typical 5%
Available Tolerance	±0.25pF, ±0.5pF, ±5%, ±10%, ±20%	±5%, ±10%, ±20%	±20%, +80/-20%, +100/-0%, GMV

Tolerance: for capacitance values below 10pF, use ±0.25pF or ±0.5pF. GMV = guaranteed minimum value

PART NUMBERING SYSTEM

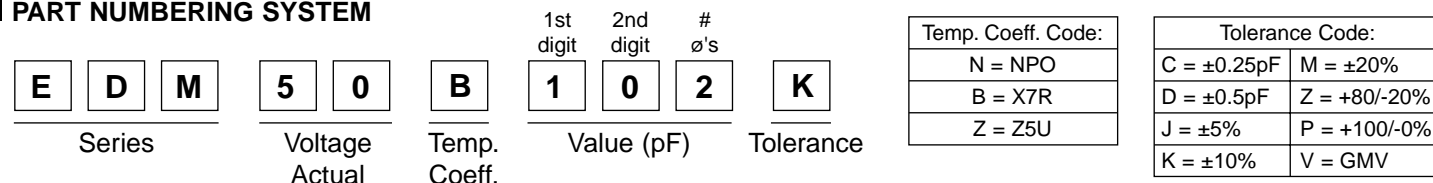

MARKING SYSTEM

Capacitance is marked in 3 digits for capacitance >100pF and marked in actual value for capacitance ≤100pF

APPLICATION NOTES

NPO: have a very low dissipation factor and are very stable over wide variation in temperature, frequency, voltage, and time. they are frequently used for precision timing, filtering, frequency setting, and tuning circuits.

X7R: are used where some capacitance variation is permissible and dissipation factor is not critical. They are frequently used for bypass, decoupling, filtering, frequency discrimination, timing, DC blocking, voltage transient suppression, instrumentation, computers, telecommunications, and automotive electronics

Z5U: dielectrics have the highest capacitance for their size. They have applications in bypass, decoupling, filtering, transient suppression, computers, and telecommunications.



■ DIMENSIONS AND CAPACITANCE RANGE

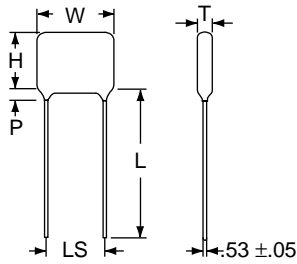

XC15, XC80

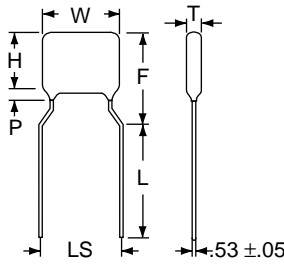

XC16, XC21

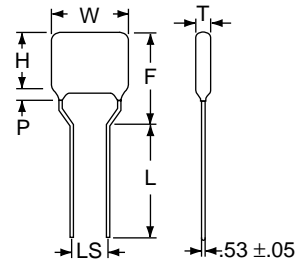

XC20

Case Size	Dimensions (mm)						Capacitance Range		
	H max.	F max.	P max.	W max.	T max.	LS ±1.0	NPO	X7R	Z5U
XC15	3.81	- - -	1.50	4.06	2.54	2.54	10pF ~ 680pF	270pF ~ 22,200pF	2,700pF ~ 100,000pF
XC16	3.81	7.62	1.50	4.06	2.54	5.08			
XC20	5.08	7.62	1.50	5.08	3.05	2.54	15pF ~ 27,000pF	0.0033μF ~ .015μF	0.0027μF ~ .033μF
XC21	5.08	7.62	1.50	5.08	3.05	5.08			
XC80	7.62	- - -	1.50	7.62	3.81	5.08	15pF ~ 18,000pF	0.0082μF ~ .1μF	0.027μF ~ 1.5μF

■ TAPE AND REEL DIMENSIONS, PACKING QUANTITY

XC15, XC80

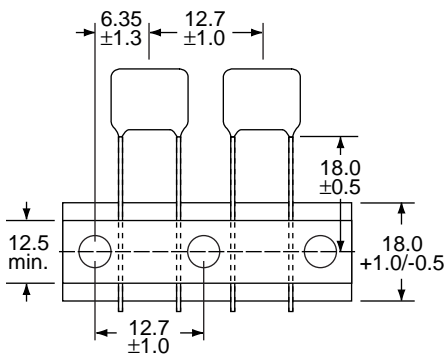

XC16, XC21

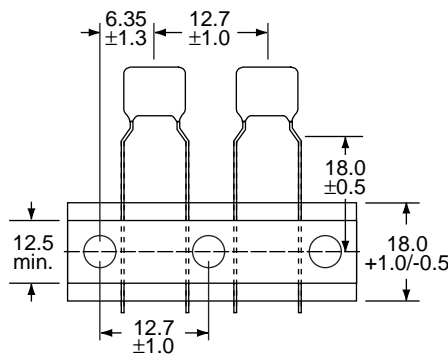

XC20

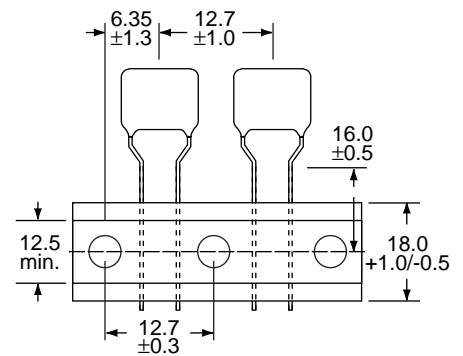

Tape & reel available, add /REEL to the end of the EDM series part number

Capacitor quantity per Tape and Reel: 3,000

Ammo Pack available, add /AP to the end of the EDM series part number

Capacitor quantity per Ammo Pack:
2,000 for XC15, XC16, XC20, XC21
1,500 for XC80

FEATURES

- 5mm size
- Designed for easy handling
- Stable mechanical structure
- Ceramic body



CHARACTERISTICS

Item	Characteristics
Operating Temperature Range	-35°C ~ +85°C
Standard Working Voltage (WVDC)	200
Breakdown Voltage (VDC)	400
Insulation Resistance	10 ⁴ MΩ @ 250WVDC
Rotation Torque	35~200gr-cm

PART NUMBERING SYSTEM

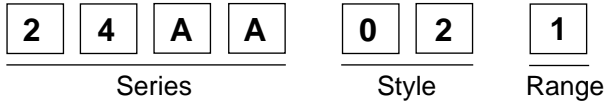

Style Code:
02 = Horizontal
08 = Vertical
07 = Surface Mount

Range Code:
0 = 1.8 ~ 6.0
1 = 2.8 ~ 12.5
2 = 3.5 ~ 20.0
3 = 5.0 ~ 30.0
4 = 9.0 ~ 50.0

SPECIFICATIONS

Capacitance Range (pF)	Temperature Coefficient (ppm/°C)	Q Factor	Color Code
1.8 ~ 6.0	NPO ±250	>300 @10MHz	Red
2.8 ~ 12.5	N600 ±300	>300 @10MHz	None
3.5 ~ 20.0	N750 ±300	>300 @10MHz	Blue
5.0 ~ 30.0	N1500 ±500	>300 @10MHz	Yellow
9.0 ~ 50.0	N1500 ±500	>200 @1MHz	Green

DIMENSIONS (mm)

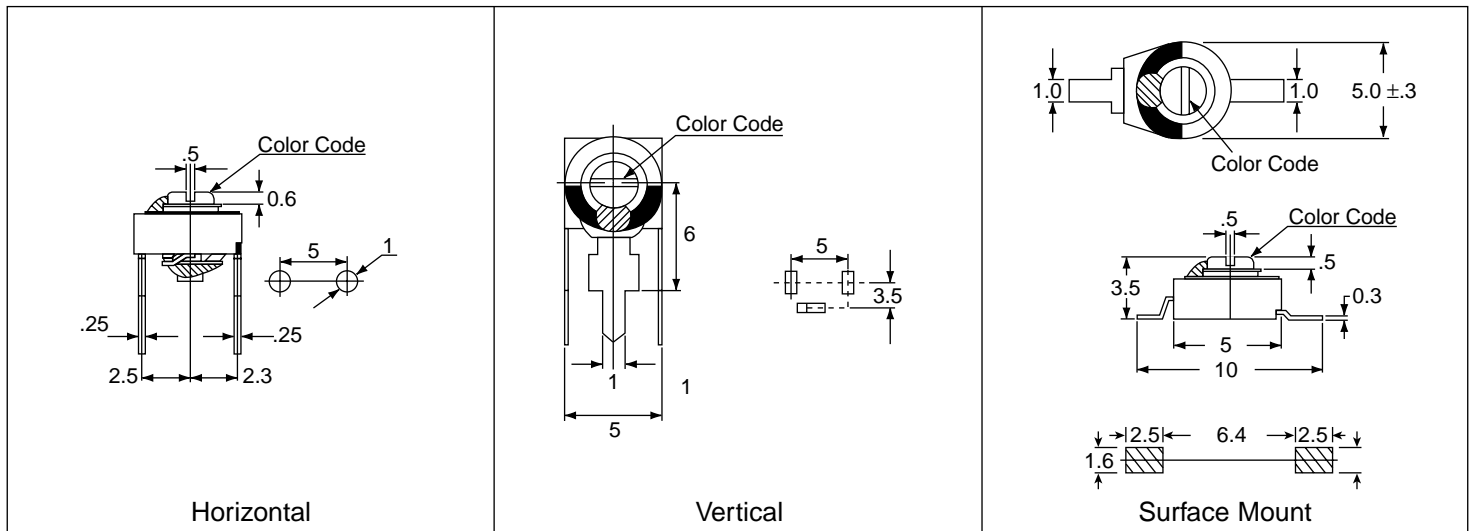

■ FEATURES

- Excellent microwave characteristics
- Aluminum ceramic stator is used in this series
- Heat, humidity, and cold have little effect on durability and performance
- Reliable characteristics shown by the high Q-factor
- Applicable to various frequencies, from low to ultra-high
- Color coded



■ CHARACTERISTICS

Item	Characteristics		
	4mm Style	6mm Style	7mm Style
Operating Temperature Range	-30°C ~ +85°C	-30°C ~ +85°C	-35°C ~ +85°C
Standard Working Voltage (WVDC)	50	50	250
Withstanding Voltage (VDC)	110	110	500
Insulation Resistance	>10 ⁴ MΩ	>10 ⁴ MΩ	>10 ⁴ MΩ
Rotation Torque	20~150gr-cm	20~200gr-cm	40~400gr-cm

■ PART NUMBERS AND SPECIFICATIONS

Diameter	Part Number	Capacity Range (pF)	Temp. Coeff. (ppm/°C)	Q Factor @10MHz	Color Code
4mm	242-1230	1.2 ~ 3.0	N100±250	>500	Black
	242-1460	1.4 ~ 6.0	N250±250	>500	Red
	242-1810	1.8 ~ 10.0	N550±300	>300	None
	242-2820	2.8 ~ 20.0	N550±300	>300	Blue
	242-4030	4.0 ~ 30.0	N1200±500	>200	Yellow
6mm	242-3010	3.0 ~ 10.0	N470±300	>300	White
	242-4221	4.2 ~ 20.0	N750±300	>300	Red
	242-6230	6.2 ~ 30.0	N750±300	>200	Green
	242-9850	9.8 ~ 50.0	N1200±500	>200	Brown
7mm 3410	242-3410-34	4.0 ~ 34	N500±800	>300	Yellow
	242-3410-45	5.0 ~ 45	N1400±800	>200	Brown
	242-3410-55	5.0 ~ 55	N1400±800	>200	Green
	242-3410-70	6.0 ~ 70	N1400±800	>200	None
7mm 3810	242-3810-12	2.0 ~ 12.0	NPO±200	>300	None
	242-3810-23	2.5 ~ 23.0	N450±200	>300	Blue
	242-3810-45	5.0 ~ 45.0	N1400±800	>200	Brown
	242-3810-55	5.0 ~ 55.0	N1400±800	>200	Green
	242-3810-70	6.0 ~ 70.0	N1400±800	>200	Gray
	242-3810-100	12.0 ~ 100.0	N1400±800	>200 / 1MHz	Black

■ DIMENSIONS (mm)

4mm Style

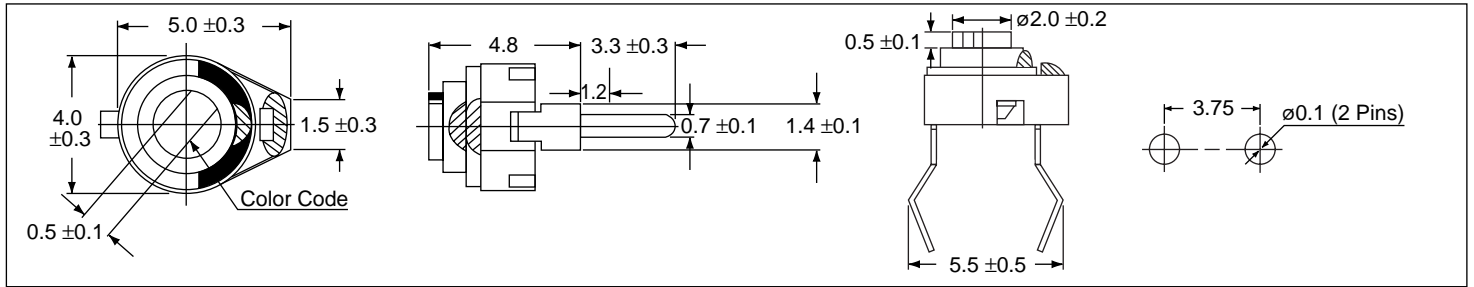

6mm

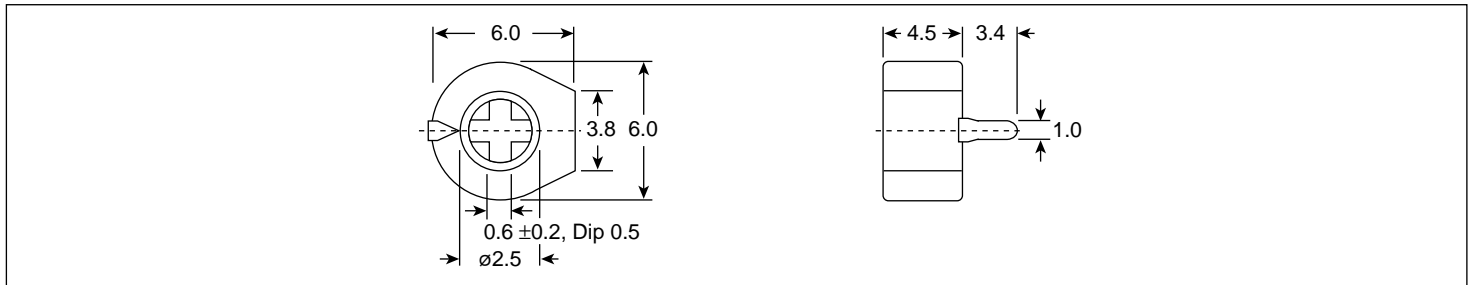

7mm 3410 Style

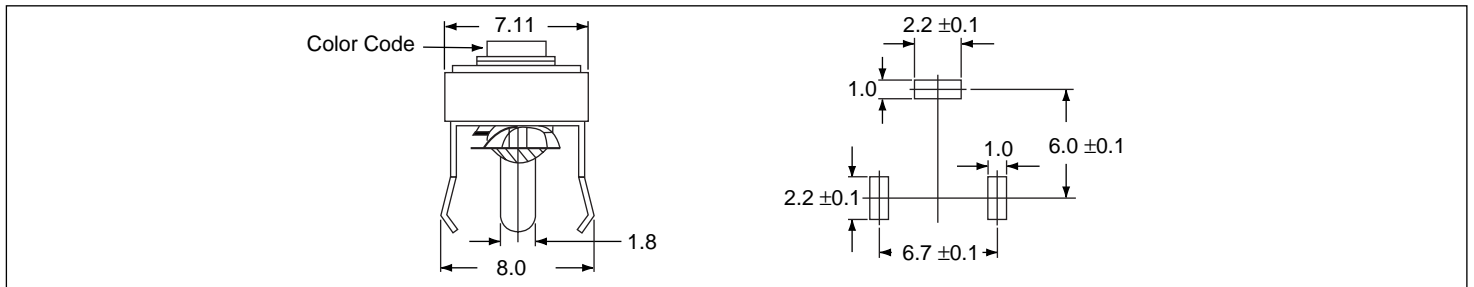

7mm 3810 Style

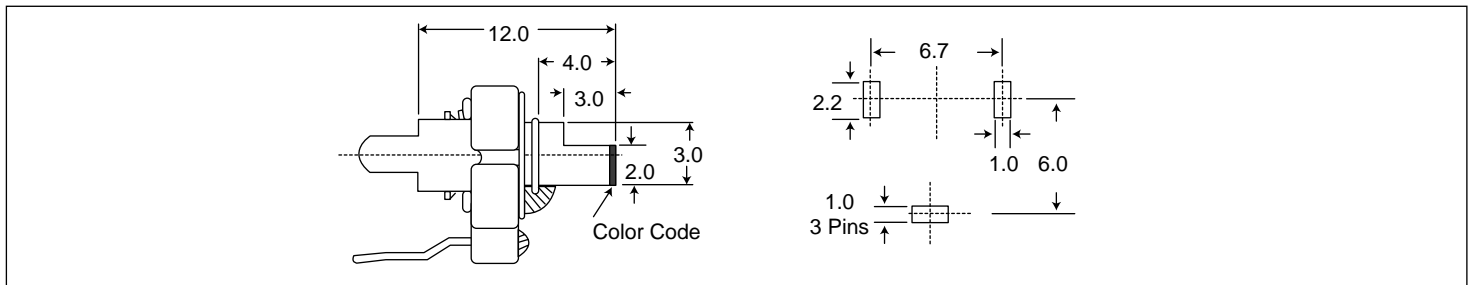

FEATURES

- High reliability
- Small size with high dielectric constant
- Low inductance
- Popular temperature coefficients available
- Wide operating temperature range
- High insulation resistance
- Case sizes: 0603, 0805, 1206, 1210



CHARACTERISTICS

Item	Characteristics		
	NPO / COG	X7R	Z5U
Operating Temperature Range	-55°C ~ +125°C	-55°C ~ +125°C	-25°C ~ +85°C
Temperature Coefficient	±30ppm/°C for C>20pF +120ppm, -40ppm/°C for C≤20pF	ΔC ±15% maximum over -55°C +125°C	ΔC ±56%-22% maximum over +10°C +85°C
Measuring Conditions for Capacitance and D.F.	1MHz, 1Vrms for C≤1,000pF 1KHz, 1Vrms for C>1,000pF	1KHz, 1Vrms	1KHz, 0.3Vrms
Dissipation Factor and Tangent of Loss Angle (Tan δ)	≥0.001 for C≥50pF ≤1.5(150/C + 7) × 10 ⁻² for C<50pF	≤0.025	≤0.030
Insulation Resis. After 60 sec. Charging at Rated Voltage 25°C	≥100GΩ or ≥1,000MΩ(C) whichever is less	≥100GΩ or ≥1,000MΩ(C) whichever is less	≥10GΩ or ≥1,000MΩ(C) whichever is less
Voltage Test 25°C	2.5 x rated voltage	2.5 x rated voltage	2.5 x rated voltage
Capacitance Aging	0	=1.5% per decade hour	=5% per decade hour

PART NUMBERING SYSTEM

C	C	5	0	2	N	1	0	1	J	/	R	E	E	L
Series		Voltage		Case Size	Temperature Coefficient	Value			Tolerance	Suffix				

CODES FOR CASE SIZE, TEMPERATURE COEFFICIENT, AND TOLERANCE

Case Size	Code
0805	1
1206	2
1210	3
0603	4

Temperature Coefficient	Code
NPO / COG	N
X7R	B
Z5U	Z
Y5V	V

Tolerance	Code	Tolerance	Code
±0.25pF	C	±20%	M
±0.5pF	D	+80% -20%	Z
±5%	J	+100% -0%	P
±10%	K	GMV	V

Suffix	Code
Tape and Reel	/REEL
Bulk	-BK

For capacitance values below 10pF, use C or D.
GMV = Guaranteed Minimum Value

CAPACITANCE RANGES

Case Size	NPO / COG		X7R		Z5U (0805, 1206, 1210) / Y5V (0603)	
	50V	100V	50V	100V	50V	100V
0603	1.0pF~470pF		100pF~0.01μF		0.01μF~0.1μF	---
0805	1.0pF~1500pF	1.0pF~1000pF	100pF~0.1μF	100pF~.022μF	2700pF~0.15μF	---
1206	1.0pF~3900pF	1.0pF~2700pF	100pF~0.1μF	100pF~.047μF	8200pF~0.47μF	---
1210	4700pF~8200pF	3300pF~5600pF	0.12μF~0.22μF	.047μF~0.1μF	0.22μF~0.68μF	---

TOLERANCE AVAILABLE

Availability	NPO / COG				X7R			Z5U		
Tolerance	±0.25pF	±0.5pF	±2%	±5%	±5%	±10%	±20%	±20%	+80% -20%	+100% -0%
Capacitance	<5pF	≤10pF	>13pF	≥10pF	All Values	All Values	All Values	All Values	All Values	All Values



■ DIMENSIONS

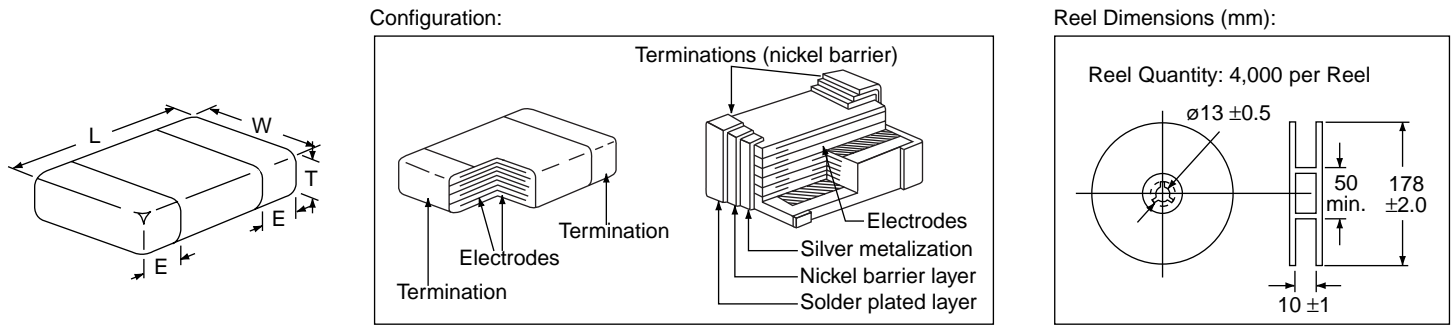

Case Size	Dimensions (mm)			
	L (length)	W (width)	T (thickness) max.	E (termination)
0603	1.52 ± 0.2	0.8 ± 0.2	.65	0.5 ± 0.2
0805	2.0 ± 0.2	1.2 ± 0.2	1.0	0.5 ± 0.2
1206	3.2 ± 0.2	1.6 ± 0.2	1.25	0.5 ± 0.2
1210	3.2 ± 0.2	2.5 ± 0.2	1.3	0.5 ± 0.2

■ TYPICAL PERFORMANCE CURVES

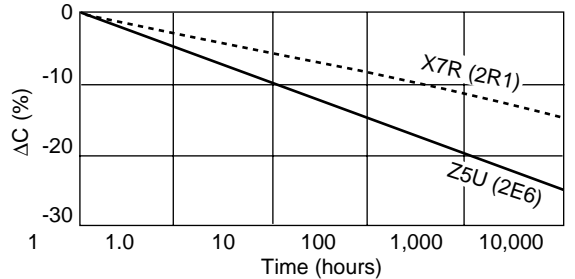
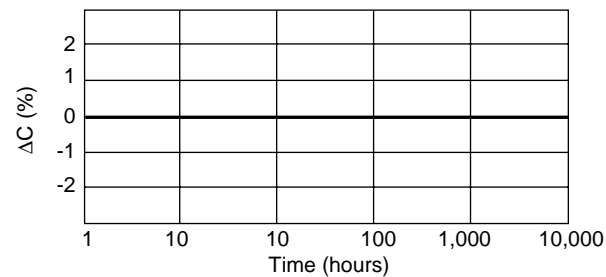
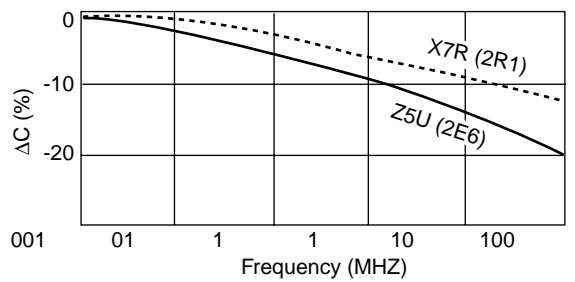
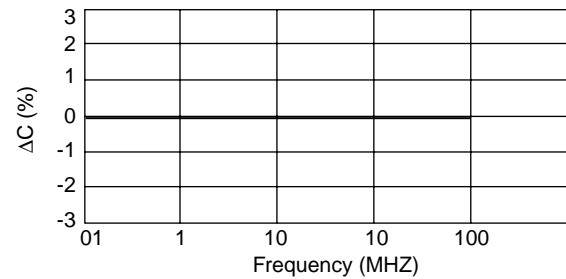
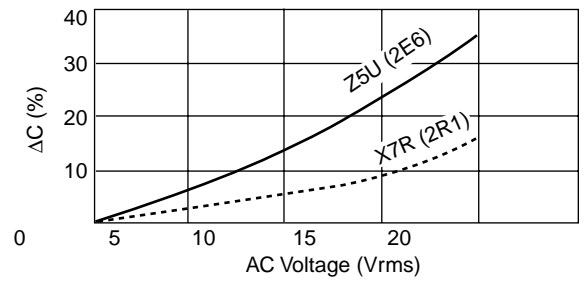
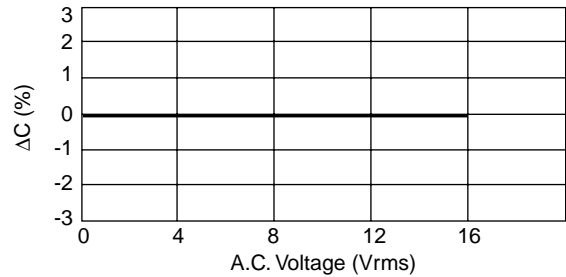
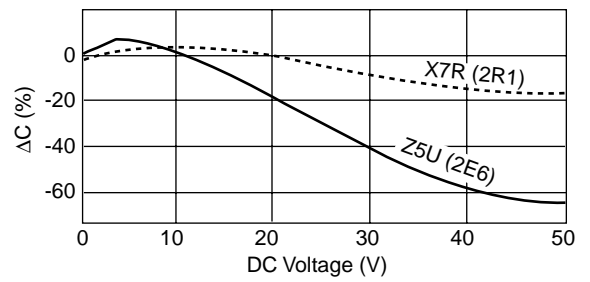
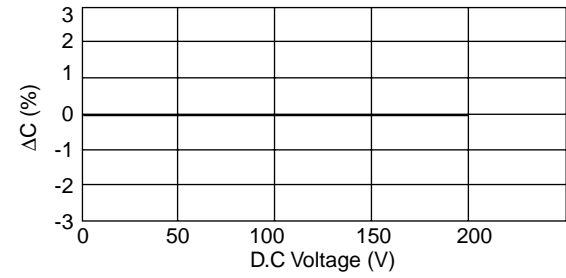
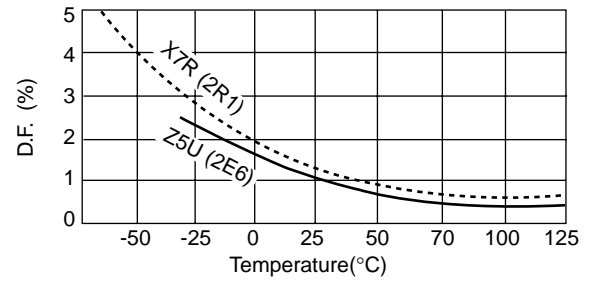
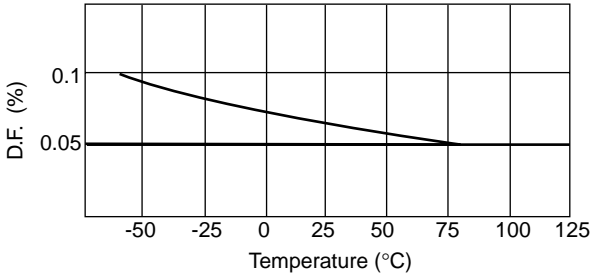
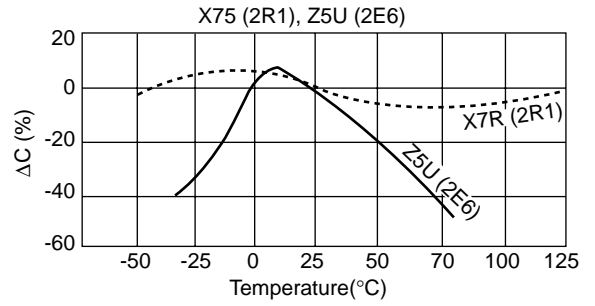
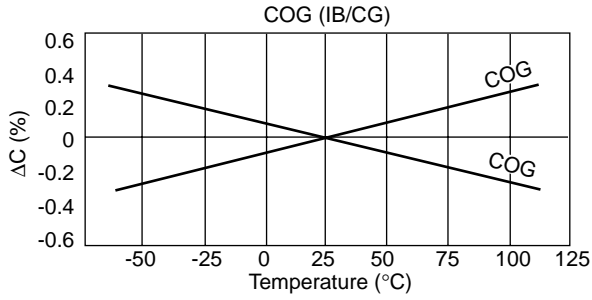

Storage:

To maintain the solderability of terminations, the following storage conditions are recommended: ambient temperature less than 40°C, relative humidity less than 70% RH, no harmful gases containing sulfur or chlorine.

Handling:

Surface mount components should be handled with care to avoid contamination or damage. The use of vacuum pick-up or plastic tweezers is recommended for manual placement. Tape and reeled packages are suitable for automatic pick and placement machines.

Preheat:

In order to minimize the risk of thermal shock during soldering, a carefully controlled preheat is required. The rate of preheat should not exceed 4°C per second and the final preheat temperature should be within 100°C of the soldering temperature for small chips such as 0603, 0805, 1206, and 1210.

Soldering:

Use mildly activated resin RA and RMA fluxes, do not use activated flux. The amount of solder in each solder joint should be controlled to prevent the damage of chips caused by the stress between solder, chips, and substrate.

Hand soldering with temperature-controlled iron not exceeding 30 watts and diameter of tip less than 3 mm is recommended, tip of iron should not contact the body directly, and the temperature of iron should be set not more than 260°C.

Recommended Soldering Profiles are as Follows:

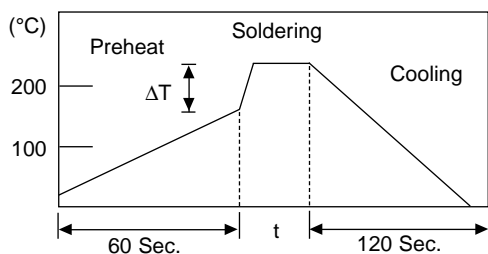

Soldering	Soldering Temp. (T)	Soldering Time (t)
Reflow	220°C~240°C	<5 seconds
Wave	220°C~230°C	<15 seconds

Chip Size	ΔT
0603, 0805, 1206, 1210	100°C

Cooling:

After soldering, cool the chips and substrate gradually to room temperature. Cooling in air is recommended to minimize stress in the solder joint. A cooling rate not to exceed 4°C per second should be used when forced cooling is necessary.

Cleaning:

All flux residue must be removed to eliminate contamination that could cause electrolytic surface corrosion. Freon, trichloroethylene or other suitable electronic-grade vapor-cleaning solvents are suitable for cleaning. Good results can be obtained by using ultrasonic cleaning at the boiling point of the solvent. The choice of the proper system is dependent upon many factors such as component mix, flux, solder paste and assembly method. The ability of the cleaning system to remove flux residues and contamination from under the chips is very important.

FEATURES

- Miniature, high density packaging
- Combinations of different ohmic value are available
- High reliability with RuO₂ paste

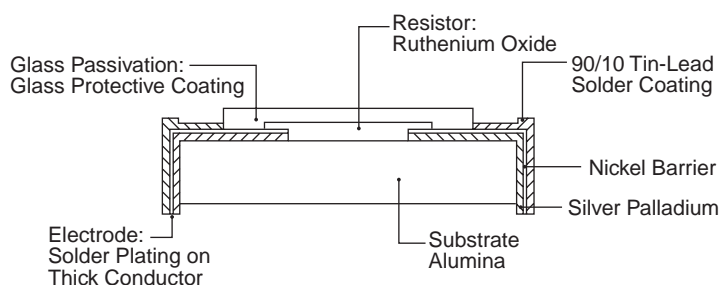

CHARACTERISTICS

Items	Characteristics
Operating Temperature Range	-55°C ~ +125°C
Temperature Coefficient Range	±220ppm/°C
Standard Resistance Range	22Ω - 1.0MΩ
Power Rating, Watts @70°C	.063 per resistor
Max. Working Voltage	50VDC
Resistance Tolerance	±5%
Moisture Resistance	1,000 hours @ +40°C, 95% RH (3.0% + 0.1Ω ΔR)
High Temperature Operation	1,000 hours @ +70°C (5.0% + 0.1Ω ΔR)
Short Time Overload	2.5 x WV for 5 seconds (1.0% + 0.1Ω ΔR)
Temperature Cycling	-55°C ~ +125°C for 5 cycles (1.0% + 0.05Ω ΔR)
Resistance to Solder Heat	260°C for 10 seconds (1.0% + 0.05Ω ΔR)
Reel Quantity	5,000 per reel

PART NUMBERING SYSTEM

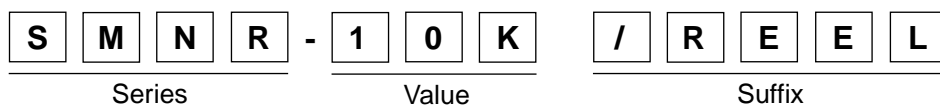

Suffix Code:	Package:
-BK	Bulk
/REEL	Tape and Reel

DERATING CURVE

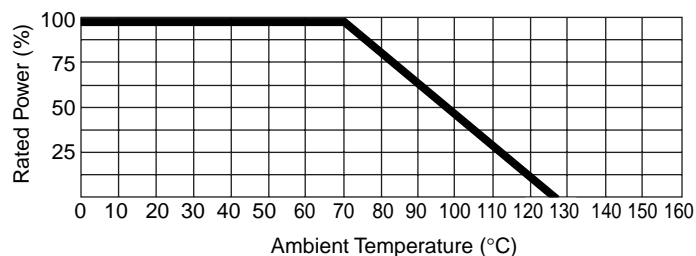

CIRCUIT CONSTRUCTION

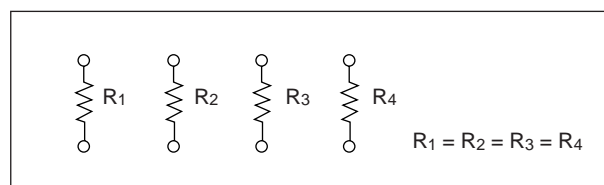

DIMENSIONS (mm)

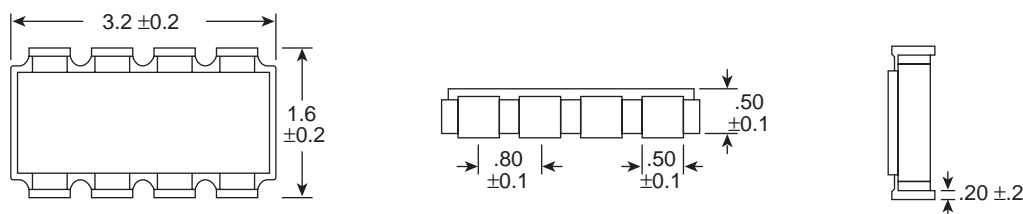

FEATURES

- High purity alumina substrate
- Wave or flow solderable
- Excellent high frequency characteristics
- Wrap around termination
- Inner electrode protection

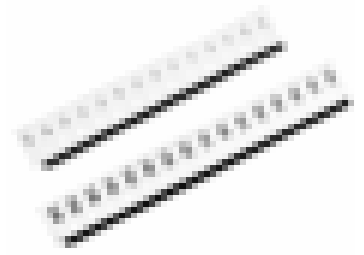

CHARACTERISTICS

Item	Characteristics
Operating Temperature Range	-55°C ~ +125°C
Temperature Coefficient	±100ppm/°C @ room temperature +100°C
Temperature Cycling	±(1.0% +0.1Ω) max. @ -55°C ~ +125°C
Short Time Overload	±(2.0% +0.1Ω) max. with rated voltage x 2.5 for 5 seconds
Humidity Load Life	±(3.0% +0.1Ω) max. @ 40°C RH 90~95%
Load Life	±(3.0% +0.1Ω) max. @ 70°C
Vibration	±(1.0% +0.1Ω) max. @ low frequency, 3 directions for 2 hours in each direction
Solderability	90% min. coverage @ 230°C for 3 seconds
Resistance to Soldering Heat	±(2.5% +0.1Ω) max. @ 260°C for 10 seconds
Termination Adhesion	±(1.0% +0.1Ω) max. @ 500g
Range of Values	10Ω ~ 1MΩ
Reel Quantity	5,000 per reel

DERATING CURVE

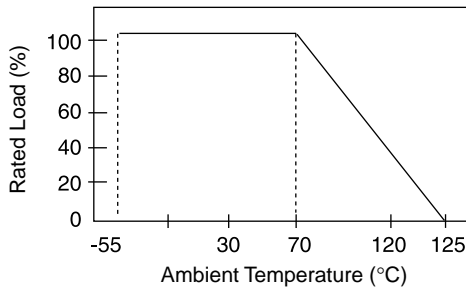

STRUCTURE

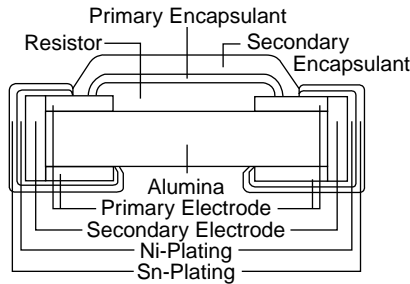

REEL DIMENSIONS (mm)

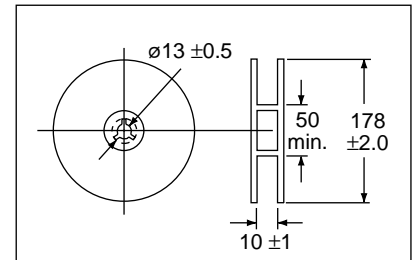

PART NUMBERING SYSTEM

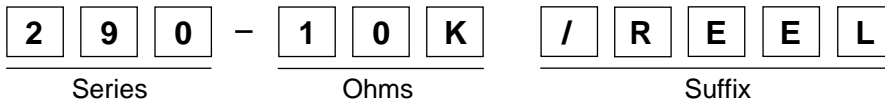

Suffix Code:	Package:
-BK	Bulk
/REEL	Tape and Reel

SERIES, SIZE, WATTAGE, VOLTAGE, AND DIMENSIONS

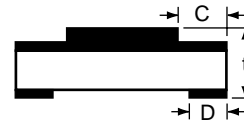
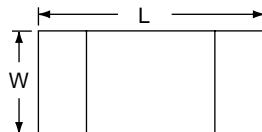

* Max. Power Rating @ 70°C, see Derating Curve.

Series	Case Size	Power Rating	Max. Power Rating *	Voltage (max.)		Dimensions (mm)				
				W.V.	O.V.	L	W	C	D	t
290	1206	1/8	1/4	200	300	3.2 ± 0.2	1.6 ± 0.2	0.45 ± 0.1	0.4 ± 0.2	0.5 ~ 0.65
292	0805	1/10	1/8	100	200	2.0 ± 0.2	1.3 ± 0.2	0.3 ± 0.1	.25 ± 0.2	0.5 ~ 0.65
302	0603	1/16	1/10	50	100	1.05 ± 0.1	0.8 ± 0.1	0.25 ± 0.1	0.25 ± 0.1	0.4 ~ 0.65
304	0402	1/16	1/10	25	50	1.00 ± 0.1	0.5 ± 0.05	0.2 ± 0.1	0.25 ± 0.1	0.3 ~ 0.4



■ STANDARD STOCKED VALUES (Ω)

10	16.9	28.7	48.7	82.5	140	237	392	665	1.13K	1.91K	3.16K	5.36K	9.09K	15.4K	26.1K	43.2K	73.2K	124K	210K	348K	590K
10.2	17.4	29.4	49.9	84.5	143	243	402	681	1.15K	1.96K	3.24K	5.49K	9.31K	15.8K	26.7K	44.2K	75K	127K	215K	357K	604K
10.5	17.8	30.1	51.1	86.6	147	249	412	698	1.18K	2.0K	3.32K	5.62K	9.53K	16.2K	27.4K	45.3K	76.8K	130K	221K	365K	619K
10.7	18.2	30.9	52.3	88.7	150	255	422	715	1.21K	2.05K	3.4K	5.76K	9.76K	16.5K	28K	46.4K	78.7K	133K	226K	374K	634K
11	18.7	31.6	53.6	90.9	154	261	432	732	1.24K	2.1K	3.48K	5.9K	10K	16.9K	28.7K	47.5K	80.6K	137K	232K	383K	649K
11.3	19.1	32.4	54.9	93.1	158	267	442	750	1.27K	2.15K	3.57K	6.04K	10.2K	17.4K	29.4K	48.7K	82.5K	140K	237K	392K	665K
11.5	19.6	33.2	56.2	95.3	162	274	453	768	1.3K	2.21K	3.65K	6.19K	10.5K	17.8K	30K	49.9K	84.5K	143K	243K	402K	681K
11.8	20	34	57.6	97.6	165	280	464	787	1.33K	2.26K	3.74K	6.34K	10.7K	18.2K	30.1K	51.1K	86.6K	147K	249K	412K	698K
12.1	20.5	34.8	59	100	169	287	475	806	1.37K	2.32K	3.83K	6.49K	11.K	18.7K	30.9K	52.3K	88.7K	150K	255K	422K	715K
12.4	21	35.7	60.4	102	174	294	487	825	1.40K	2.37K	3.92K	6.65K	11.3K	19.1K	31.6K	53.6K	90.9K	154K	261K	432K	732K
12.7	21.5	36.5	61.9	105	178	300	499	845	1.43K	2.43K	4.02K	6.81K	11.5K	19.6K	32.4K	54.9K	93.1K	158K	267K	442K	750K
13	22.1	37.4	63.4	107	182	301	511	866	1.47K	2.49K	4.12K	6.98K	11.8K	20K	33.2K	56.2K	95.3K	162K	274K	453K	768K
13.3	22.6	38.3	64.9	110	187	309	523	887	1.5K	2.55K	4.22K	7.15K	12.1K	20.5K	34.K	57.6K	97.6K	165K	280K	464K	787K
13.7	23.2	39.2	66.5	113	191	316	536	909	1.54K	2.61K	4.32K	7.32K	12.4K	21.K	34.8K	59.0K	100K	169K	287K	475K	806K
14	23.7	40.2	68.1	115	196	324	549	931	1.58K	2.67K	4.42K	7.5K	12.7K	21.5K	35.7K	60.4K	102K	174K	294K	487K	825K
14.3	24.3	41.2	69.8	118	200	332	562	953	1.62K	2.74K	4.53K	7.68K	13K	22.1K	36.5K	61.9K	105K	178K	300K	499K	845K
14.7	24.9	42.2	71.5	121	205	340	576	976	1.65K	2.8K	4.64K	7.87K	13.3K	22.6K	37.4K	63.4K	107K	182K	301K	511K	866K
15	25.5	43.2	73.2	124	210	348	590	1.0K	1.69K	2.87K	4.75K	8.06K	13.7K	23.2K	38.3K	64.9K	110K	187K	309K	523K	887K
15.4	26.1	44.2	75	127	215	357	604	1.02K	1.74K	2.94K	4.87K	8.25K	14.K	23.7K	39.2K	66.5K	113K	191K	316K	536K	909K
15.8	26.7	45.3	76.8	130	221	365	619	1.05K	1.78K	3.0K	4.99K	8.45K	14.3K	24.3K	40.2K	68.1K	115K	196K	324K	549K	931K
16.2	27.4	46.4	78.7	133	226	374	634	1.07K	1.82K	3.01K	5.11K	8.66K	14.7K	24.9K	41.2K	69.8K	118K	200K	332K	562K	953K
16.5	28	47.5	80.6	137	232	383	649	1.1K	1.87K	3.09K	5.23K	8.87K	15K	25.5K	42.2K	71.5K	121K	205K	340K	576K	976K
																					1M

FEATURES

- High purity alumina substrate
- Wave or flow solderable
- Excellent high frequency characteristics
- Wrap around termination
- Inner electrode protection
- Resistance range 0Ω ~ 10MΩ

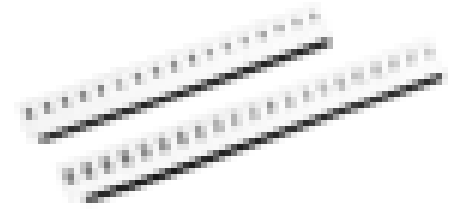

CHARACTERISTICS

Item	Characteristics
Oper. Temp. Range	-55°C ~ +125°C
Temp. Coefficient	<10Ω is -100~+600ppm/°C; 10~1MΩ is ±200ppm/°C; >1MΩ is -400~+100ppm/°C @ room temp. +100°C
Temperature Cycling	±(1.0% +0.1Ω) max. @ -55°C ~ +125°C
Short Time Overload	±(2.0% +0.1Ω) max. w/rated voltage x 2.5 for 5 sec.
Humidity Load Life	±(3.0% +0.1Ω) max. @40°C RH 90~95%
Load Life	±(3.0% +0.1Ω) max. @ 70°C

Item	Characteristics
Vibration	±(1.0% +0.1Ω) max. @ low frequency, 3 directions for 2 hours in each direction
Solderability	90% min. coverage @ 230°C for 3 seconds
Soldering Heat Resistance	±(2.5% +0.1Ω) max. @ 260°C for 10 seconds
Termination Adhesion	±(1.0% +0.1Ω) max. @ 500g
Zero Ohm Jumper	Upper limit .05Ω; Add current rating
Reel Quantity	5,000 per reel

PART NUMBERING SYSTEM

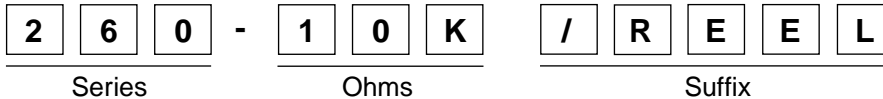

Suffix Code:	Package:
-BK	Bulk
/REEL	Tape and Reel

SERIES, SIZE, WATTAGE, VOLTAGE, AND DIMENSIONS

Series	Case Size	Power Rating	Power* Rating	Voltage (max.)		Dimensions (mm)				
				W.V.	O.V.	L	W	C	D	t
263	1206	1/8	1/4	200	300	3.2 ±0.2	1.6 ±0.2	0.45 ±0.1	0.4 ±0.2	0.5 ~ 0.65
260	0805	1/10	1/8	100	200	2.0 ±0.1	1.25 ±0.2	0.4 ±0.2	0.3 ±0.2	0.4 ~ 0.65
301	0603	1/16	1/10	50	100	1.05 ±0.1	0.8 ±0.1	0.25 ±0.1	0.25 ±0.1	0.4 ~ 0.65
303	0402	1/16	1/10	25	50	1.00 ±0.1	0.5 ±0.05	0.2 ±0.1	0.25 ±0.1	0.3 ~ 0.4

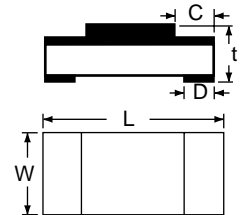

* Max. Power Rating @ 70°C, see Derating Curve.

DERATING CURVE

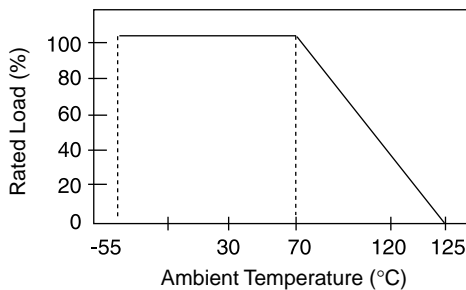

STRUCTURE

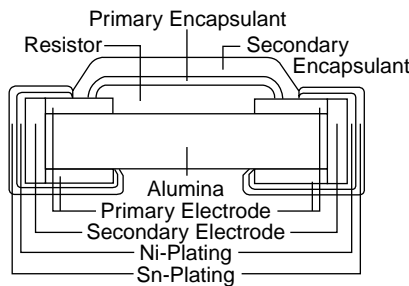

REEL DIMENSIONS (mm)

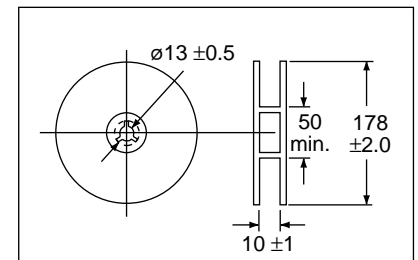

STANDARD STOCKED VALUES (Ω)

0	2.0	4.3	9.1	20	43	91	200	430	910	2K	4.3K	9.1K	20K	43K	91K	200K	430K	820K	1.8M	3.9M	8.2M
1.0	2.2	4.7	10	22	47	100	220	470	1K	2.2K	4.7K	10K	22K	47K	100K	220K	470K	910K	2M	4.3M	9.1M
1.1	2.4	5.1	11	24	51	110	240	510	1.1K	2.4K	5.1K	11K	24K	51K	110K	240K	510K	1M	2.2M	4.7M	10M
1.2	2.7	5.6	12	27	56	120	270	560	1.2K	2.7K	5.6K	12K	27K	56K	120K	270K	560K	1.1M	2.4M	5.1M	
1.3	3.0	6.2	13	30	62	130	300	620	1.3K	3K	6.2K	13K	30K	62K	130K	300K	620K	1.2M	2.7M	5.6M	
1.5	3.3	6.8	15	33	68	150	330	680	1.5K	3.3K	6.8K	15K	33K	68K	150K	330K	660K	1.3M	3M	6.2M	
1.6	3.6	7.5	16	36	75	160	360	750	1.6K	3.6K	7.5K	16K	36K	75K	160K	360K	680K	1.5M	3.3M	6.8M	
1.8	3.9	8.2	18	39	82	180	390	820	1.8K	3.9K	8.2K	18K	39K	82K	180K	390K	750K	1.6M	3.6M	7.5M	

FEATURES

- Resistance: less than 0.01Ω
- Color coding: one black band
- Compatible with automatic insertion equipment
- Ideal short circuit between points on P.C. boards
- Lead material: tin plated copper
- Body material: electrical grade high performance molding compound



CHARACTERISTICS

Items	Characteristics
Maximum Resistance	0.00165Ω
Insulation Resistance	Dry is 10,000MΩ; Wet is 100MΩ
Dielectric Withstanding Voltage	1 Atmosphere is 500VRMS; High Altitude is 325VRMS
Insulation Flammability	Resistor insulation is self extinguishing within 10 seconds after externally applied flame is removed
Current Rating	25A at +25°C derating to 0A at +150°C

PART NUMBERING SYSTEM

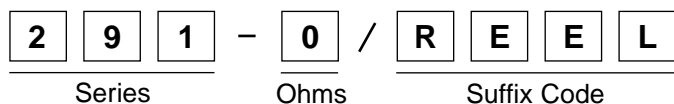

SERIES, WATTAGE, SIZE, DIMENSIONS, AND AVAILABLE PACKAGING

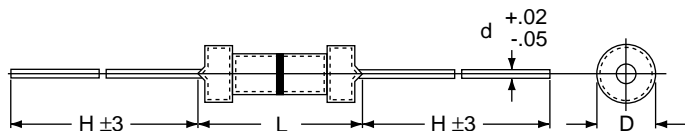

Suffix Code:	Package:
1000	Bulk
REEL	Tape and Reel
AP	Ammo Pack

Series	Watts	Size	Dimensions (mm)						Standard Quantities Available		
			L max.	L min.	D max.	D min.	H	d	Bulk	Tape and Reel	Ammo Pack
299	1/8W	Standard	4.2	3.2	2.0	1.7	28	0.5	1,000	5,000	2,000
291	1/4W	Standard	6.8	5.6	2.5	2.1	28	0.6	1,000	5,000	1,000

FEATURES

- $\pm 5\%$ tolerance
- High quality performance at economical prices
- Compatible with automatic insertion equipment
- Flame retardant type available
- Weldable type with copper plated lead wire available
- Values below 1Ω or above $10M\Omega$ are available by special request, please ask for details



CHARACTERISTICS

Item	Characteristics
Operating Temperature Range	$-55^{\circ}\text{C} \sim +155^{\circ}\text{C}$
Temperature Coefficient	$1\Omega \sim 91K\Omega$ is $0 \sim -450\text{ppm}/^{\circ}\text{C}$; $100K\Omega \sim 1M\Omega$ is $0 \sim -700\text{ppm}/^{\circ}\text{C}$; $1.1M\Omega \sim 10M\Omega$ is $-800 \sim -700\text{ppm}/^{\circ}\text{C}$ Test methods: natural resistance change per temp. $^{\circ}\text{C}$; $[R_2 - R_1 / R_1(t_2 - t_1)] \times 10^6 (\text{ppm}/^{\circ}\text{C})$; R_1 is resis. value at room temp. (t_1); R_2 is resis. value at room temp. $+100^{\circ}\text{C}$ (t_2); Test pattern is room temp., room temp. $+100^{\circ}\text{C}$.
Dielectric Withstanding Voltage	No evidence of flashover mechanical damage, arcing or insulation breakdown. Test method is resistors are clamped in the trough of a 90° metallic V-block and tested at the maximum overload voltage for $60 +10/-0$ seconds.
Temperature Cycling	$\pm 1\% +0.05\Omega$ max. with no evidence of mechanical damage. Test method is five cycles for duty cycle as follows: step 1 at $-55^{\circ}\text{C} \pm 3^{\circ}\text{C}$ for 30 min.; step 2 at room temp. for 10~15 min.; step 3 at $+155^{\circ}\text{C} \pm 2^{\circ}\text{C}$ for 30 min.; step 4 at room temp. for 10~15 min.
Short-Time Overload (permanent resistance change)	$\pm 1\% +0.05\Omega$ max. with no evidence of mechanical damage. Test method is the application of a potential of 2.5 times RCWV for 5 seconds.
Load Life in Humidity	For normal type: $<100K\Omega$ is $\pm 3\%$, $\geq 100K\Omega$ is $\pm 5\%$. For flame retardant type: $<100K\Omega$ is $\pm 5\%$, $\geq 100K\Omega$ is $\pm 10\%$. Test method is 1,000 hours operating at RCWV with duty cycle of 1.5 hours "on", 0.5 hour "off" in a humidity test chamber controlled at $40^{\circ}\text{C} \pm 2^{\circ}\text{C}$ and 90~95% relative humidity.
Load Life (permanent resistance change)	For normal type: $<56K\Omega$ is $\pm 2\%$, $\geq 56K\Omega$ is $\pm 3\%$. For flame retardant type: $<100K\Omega$ is $\pm 5\%$, $\geq 100K\Omega$ is $\pm 10\%$. Test method is 1,000 hours operating at RCWV with duty cycle of 1.5 hours "on", 0.5 hour "off" at $+70^{\circ}\text{C} \pm 2^{\circ}\text{C}$ ambient.
Insulation Resistance	$10,000M\Omega$ min. Test method is resistors are clamped in the trough of a 90° metallic V-block and tested at the maximum overload voltage for $60 +10/-0$ seconds.
Resistance to Soldering Heat (permanent resistance change)	$\pm 1\% +0.05\Omega$ max. with no evidence of mechanical damage. Test method is leads are immersed $3.2\text{--}4.8\text{mm}$ from the body in $350^{\circ}\text{C} \pm 10^{\circ}\text{C}$ solder for 3 ± 0.5 seconds

DERATING CURVE

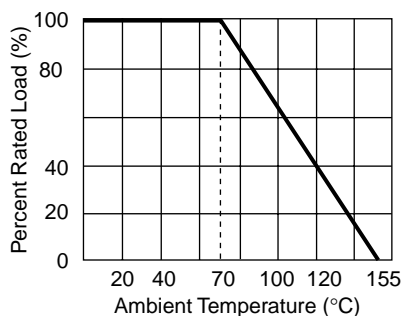

CURRENT NOISE

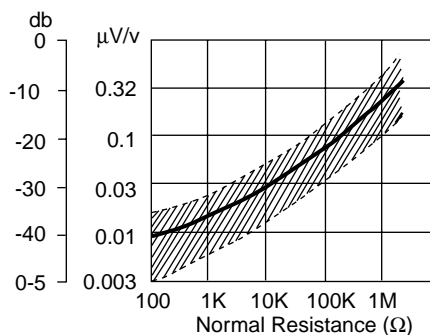

TEMPERATURE COEFFICIENT

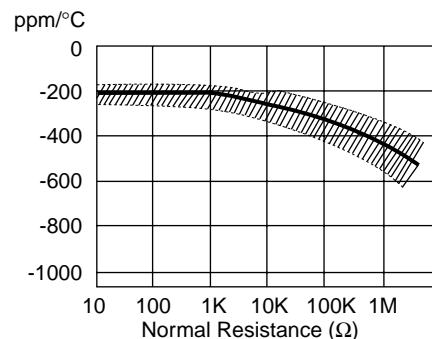

PART NUMBERING SYSTEM

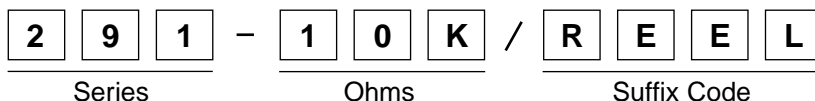

■ SERIES, WATTAGE, SIZE, VOLTAGE, DIMENSIONS, AND AVAILABLE PACKAGING

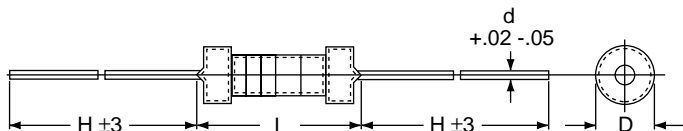

Suffix Code:	Package:
1000	Bulk
REEL	Tape and Reel
AP	Ammo Pack

Series	Watts	Size	Voltage (max.)		Dimensions (mm)						Standard Quantities Available		
			W.V.	O.V.	L max.	L min.	D max.	D min.	H	d	Bulk	Tape and Reel	Ammo Pack
291S	1/4W	Small	250	500	4.2	3.2	2.0	1.7	28	0.5	1,000	5,000	2,000
293S	1/2W	Small	350	700	9	5.6	3.0	2.1	28	0.6	1,000	5,000	1,000
294S	1W	Small	500	1,000	12	10.5	5.0	4.0	28	0.7	1,000	3,000	1,000
297S	2W	Small	500	1,000	12	10.5	5.0	4.0	28	0.7	1,000	1,000	1,000
299	1/8W	Standard	200	400	4.2	3.2	2.0	1.7	28	0.5	1,000	5,000	2,000
291	1/4W	Standard	250	500	6.8	5.6	2.5	2.1	28	0.6	1,000	5,000	1,000
293	1/2W	Standard	350	700	10	8.5	3.5	3.0	28	0.6	1,000	3,000	1,000
294	1W	Standard	500	1,000	16	14.5	5.5	4.5	28	0.8	1,000	1,000	1,000
297	2W	Standard	500	1,000	16	14.5	5.5	4.5	28	0.8	1,000	500	500

■ STANDARD VALUES (Ω)

0.5	2.0	4.3	9.1	20	43	91	200	430	910	2K	3.9K	8.2K	18K	39K	82K	180K	390K	820K	1.8M	3.9M	8.2M
1.0	2.2	4.7	10	22	47	100	220	470	1K	2.2K	4.3K	9.1K	20K	43K	91K	200K	430K	910K	2M	4.3M	9.1M
1.1	2.4	5.1	11	24	51	110	240	510	1.1K	2.4K	4.7K	10K	22K	47K	100K	220K	470K	1M	2.2M	4.7M	10M
1.2	2.7	5.6	12	27	56	120	270	560	1.2K	2.7K	5.1K	11K	24K	51K	110K	240K	510K	1.1M	2.4M	5.1M	15M
1.3	3.0	6.2	13	30	62	130	300	620	1.3K	3K	5.6K	12K	27K	56K	120K	270K	560K	1.2M	2.7M	5.6M	22M
1.5	3.3	6.8	15	33	68	150	330	680	1.5K	3.2K	6.2K	13K	30K	62K	130K	300K	620K	1.3M	3M	6.2M	
1.6	3.6	7.5	16	36	75	160	360	750	1.6K	3.3K	6.8K	15K	33K	68K	150K	330K	680K	1.5M	3.3M	6.8M	
1.8	3.9	8.2	18	39	82	180	390	820	1.8K	3.6K	7.5K	16K	36K	75K	160K	360K	750K	1.6M	3.6M	7.5M	

FEATURES

- ±1% tolerance
- Epoxy coated miniature resistors
- Nickel chromium ceramic substrate
- Alloy coated leads
- Welded end caps
- EIA standard color coding



CHARACTERISTICS

Item	Characteristics
Operating Temperature Range	-55°C ~ +155°C
Temperature Coefficient	±50ppm/°C standard (±15ppm/°C, ±25ppm/°C, ±100ppm/°C, and ±200ppm/°C available upon special request). Test methods: natural resistance change per temp. °C; $[R_2 - R_1 / R_1(t_2 - t_1)] \times 10^6$ (ppm/°C); R ₁ is resis. value at room temp. (t ₁); R ₂ is resis. value at room temp.+100°C (t ₂); Test pattern is room temp., room temp.+100°C.
Dielectric Withstanding Voltage	No evidence of flashover mechanical damage, arcing or insulation breakdown. Test method is resistors are clamped in the trough of a 90° metallic V-block and tested at the maximum overload voltage for 60 +10/-0 seconds.
Temperature Cycling	±1% +0.05Ω max. with no evidence of mechanical damage. Test method is five cycles for duty cycle as follows: step 1 at -55°C ±3°C for 30 min.; step 2 at room temp. for 10~15 min.; step 3 at +155°C ±2°C for 30 min.; step 4 at room temp. for 10~15 min.
Short-Time Overload (permanent resistance change)	±0.5% +0.05Ω max. with no evidence of mechanical damage. Test method is the application of a potential of 2.5 times RCWV for 5 seconds.
Pulse Overload	±1% +0.05Ω max. with no evidence of mechanical damage. Test method is 1,000 cycles operating at 4 times RCWV with duty cycle of 1 second "on", 25 seconds "off".
Humidity (steady rate) (temporary resistance change)	±2% +0.05Ω max. with no evidence of mechanical damage. Test method is 240 hours exposure in a humidity test chamber controlled at 40°C ±2°C and 90~95% relative humidity.
Load Life in Humidity	±5% +0.05Ω max. with no evidence of mechanical damage. Test method is 1,000 hours operating at RCWV with duty cycle of 1.5 hours "on", 0.5 hour "off" in a humidity test chamber controlled at 40°C ±2°C and 90~95% relative humidity.
Load Life (permanent resistance change)	±5% +0.05Ω max. with no evidence of mechanical damage. Test method is 1,000 hours operating at RCWV with duty cycle of 1.5 hours "on", 0.5 hour "off" at +70°C ±2°C ambient.
Terminal Strength	No evidence of mechanical damage. Test methods as follows: Direct Load; resistance to a 2.5kg direct load for 10 seconds in direction of longitudinal axis of the terminal leads. Twist Test; terminal leads are bent through 90° at a point of about 6mm from the body of the resistor and are rotated through 360° about the original axis of the bent terminal in alternating direction for a total of 3 rotations.
Solderability	95% coverage min. Test method is that the area is covered with a new, smooth, clean, shiny and continuous surface free from concentrated pinholes. Test temperature of solder is +235°C ±5°C. Time in solder is 3 +.5/-0 seconds.
Resistance to Solvent	No deterioration of protective coating and markings. Test method is that the resistors are immersed in a bath of trichloethane completely for 3 minutes with ultrasonic.

LOAD LIFE

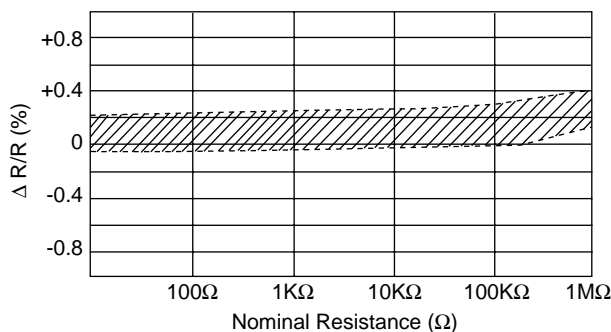

DERATING CURVE

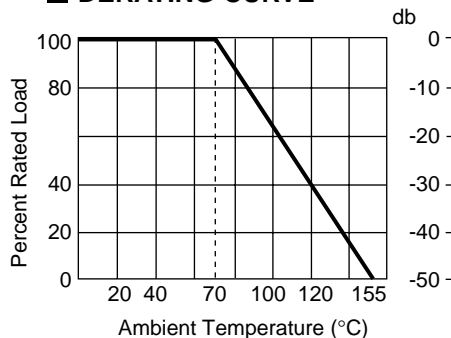

PART NUMBERING SYSTEM

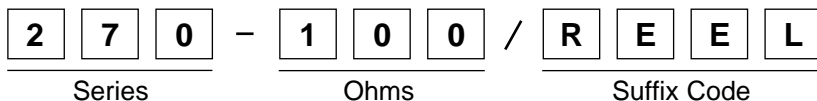

Suffix Code:	Package:
1000	Bulk
REEL	Tape and Reel
AP	Ammo Pack



■ SERIES, WATTAGE, SIZE, VOLTAGE, DIMENSIONS, AND AVAILABLE PACKAGING

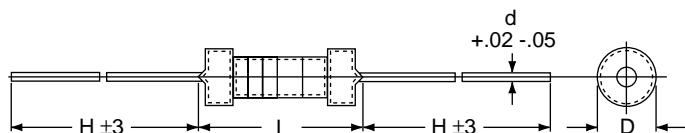

Series	Watts	Standard Range of Values (Ω)	Voltage (max.)		Dimensions (mm)				Standard Quantities Available		
			W.V.	O.V.	L max.	D max.	H	d	Bulk	Tape and Reel	Ammo Pack
270	1/8	1~10M	200	400	4.2	2.0	28	0.5	1,000	5,000	2,000
271	1/4	1~10M	250	500	6.8	2.5	28	0.6	1,000	5,000	1,000
273	1/2	1~10M	350	700	10	3.5	28	0.6	1,000	3,000	1,000
305	1	51.1~1M	500	1,000	12	5.0	28	0.7	1,000	2,500	-- N/A --
306	2	51.1~1M	500	1,000	16	5.5	28	0.8	1,000	-- N/A --	-- N/A --

■ STANDARD VALUES (Ω)

4.02	17.4	29.4	48.7	82	147	255	422	681	1.21K	2.2K	3.65K	6.2K	10.7K	19.1K	33K	53.6K	91K	165K	280K	470K	820K
4.75	17.8	30	49.9	82.5	150	261	430	698	1.24K	2.21K	3.74K	6.34K	11K	19.6K	33.2K	54.9K	93.1K	169K	287K	475K	825K
10	18	30.1	51	84.5	154	267	432	715	1.27K	2.26K	3.83K	6.49K	11.3K	20K	33.6K	56K	95.3K	174K	294K	487K	845K
10.2	18.2	30.9	51.1	86.6	158	270	442	732	1.3K	2.32K	3.9K	6.65K	11.5K	20.5K	34K	56.2K	97.6K	178K	300K	499K	866K
10.5	18.7	31.6	52.3	88.7	160	274	453	750	1.33K	2.37K	3.92K	6.8K	11.8K	21K	34.8K	57.6K	100K	180K	301K	511K	887K
10.7	19.1	32.4	53.6	90.9	162	280	464	768	1.37K	2.4K	4.02K	6.81K	12K	21.5K	35.7K	59K	102K	182K	309K	523K	909K
11	19.6	33	54.9	91	165	287	470	787	1.4K	2.43K	4.12K	6.98K	12.1K	22K	36K	60.4K	105K	187K	316K	536K	910K
11.3	20	33.2	56	93.1	169	294	475	806	1.43K	2.49K	4.22K	7.15K	12.4K	22.1K	36.5K	61.9K	107K	191K	324K	549K	931K
11.5	20.5	34	56.2	95.3	174	300	487	820	1.47K	2.55K	4.32K	7.32K	12.7K	22.6K	37.4K	62K	110K	192K	330K	560K	953K
11.8	21	34.8	57.6	97.6	178	301	499	825	1.5K	2.61K	4.42K	7.5K	13K	23.2K	38.3K	63.4K	113K	196K	332K	562K	976K
12	21.5	35.7	59	100	180	309	510	845	1.54K	2.67K	4.53K	7.68K	13.3K	23.7K	39K	64.9K	115K	200K	340K	576K	1.0M
12.1	22	36	60.4	102	182	316	511	866	1.58K	2.7K	4.64K	7.87K	13.7K	24K	39.2K	66.5K	118K	205K	348K	590K	1.5M
12.4	22.1	36.5	61.9	105	187	324	523	887	1.6K	2.74K	4.7K	8.06K	14K	24.3K	40.2K	68K	120K	210K	357K	604K	2.2M
12.7	22.6	37.4	62	107	191	330	536	909	1.62K	2.8K	4.75K	8.2K	14.3K	24.9K	41.2K	68.1K	121K	215K	360K	619K	
13	23.2	38.3	63.4	110	196	332	549	910	1.65K	2.87K	4.87K	8.25K	14.7K	25.5K	42.2K	69.8K	124K	220K	365K	620K	
13.3	23.7	39	64.9	113	200	340	560	931	1.69K	2.94K	4.99K	8.45K	15K	26.1K	43K	71.5K	127K	221K	374K	634K	
13.7	24	39.2	66.5	115	205	348	562	953	1.74K	3.0K	5.1K	8.66K	15.4K	26.7K	43.2K	73.2K	130K	226K	383K	649K	
14	24.3	40.2	68	118	210	350	565	976	1.78K	3.01K	5.11K	8.8K	15.8K	27K	44.2K	75K	133K	232K	390K	665K	
14.3	24.7	41.2	68.1	120	215	357	576	1K	1.8K	3.09K	5.23K	8.87K	16K	27.4K	45.3K	76.8K	137K	237K	392K	680K	
14.7	24.9	42.2	69.8	121	220	360	590	1.02K	1.82K	3.16K	5.36K	9.09K	16.2K	28K	46.4K	78.7K	140K	240K	402K	681K	
15	25.5	43	71.5	124	221	365	604	1.05K	1.87K	3.24K	5.49K	9.1K	16.5K	28.7K	47K	80.6K	143K	243K	412K	698K	
15.4	26.1	43.2	73.2	127	226	374	619	1.07K	1.91K	3.3K	5.6K	9.31K	16.9K	29.4K	47.5K	82K	147K	249K	422K	715K	
15.8	26.7	44.2	75	130	232	383	620	1.1K	1.96K	3.32K	5.62K	9.53K	17.4K	30K	48.7K	82.5K	150K	255K	430K	732K	
16	27	45.3	75.5	133	237	390	634	1.13K	2K	3.4K	5.76K	9.76K	17.8K	30.1K	49.9K	84.5K	154K	261K	432K	750K	
16.2	27.4	46.4	76.8	137	240	392	649	1.15K	2.05K	3.48K	5.9K	10K	18K	30.9K	51K	86.6K	158K	267K	442K	768K	
16.5	28	47	78.7	140	243	402	665	1.18K	2.1K	3.57K	6.04K	10.2K	18.2K	31.6K	51.1K	88.7K	160K	270K	453K	787K	
16.9	28.7	47.5	80.6	143	249	412	680	1.2K	2.15K	3.6K	6.19K	10.5K	18.7K	32.4K	52.3K	90.9K	162K	274K	464K	806K	

■ DIMENSIONS (mm), AMMO PACK AND TAPE AND REEL

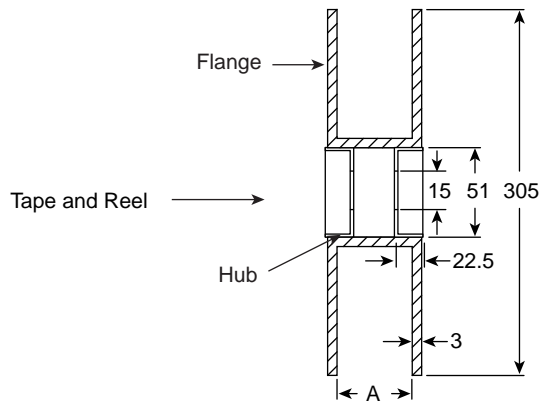
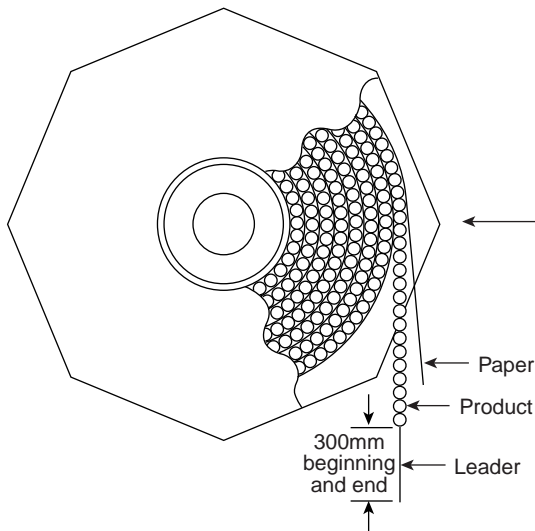
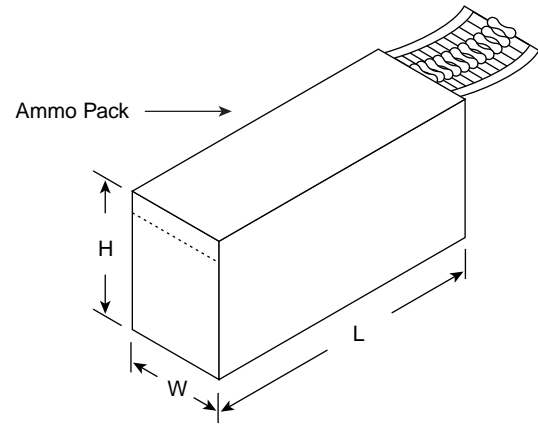
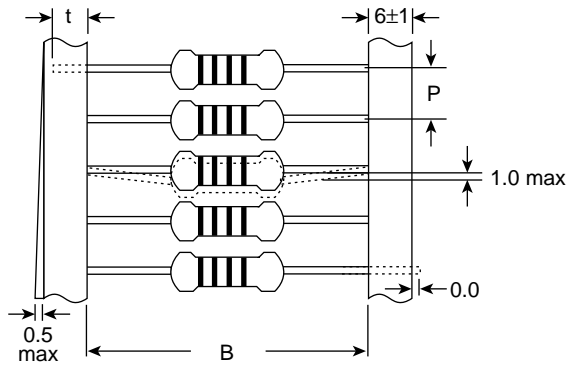

Series		Power Rating	Dimensions (mm)			Quantity Per Box	Ammo Pack			Reel	
CF	MF		B ±1	P ±0.2	t (min.)		Dimensions (mm)			Quantity Per Reel	Dim. (mm) A ±2
					L ±5	W ±5	H ±5				
299	270	1/8	52	5	4	2000	250	75	56	5000	73
291	271	1/4	52	5	4	1000	250	75	56	5000	73
293	273	1/2	52	5	4	1000	250	75	56	3000	73
294	---	1	64	10	5	1000	250	75	80	2500	73

FEATURES

- Low inductance
- Low capacitance
- Compared with film-type resistors, carbon composition resistors have better pulse endurance characteristics



CHARACTERISTICS

Item	Characteristics
Operating Temperature Range	-55°C ~ +125°C
Short Time Overload	±(2.5% +0.05Ω)
Effect of Soldering	±(3% +0.05Ω)
Temperature Cycling	±4%
Insulation Resistance	10,000MΩ min.

DERATING CURVE

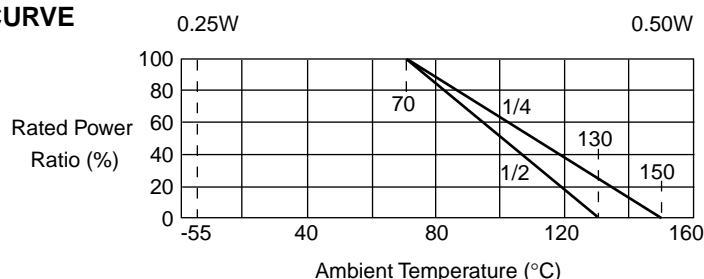

PART NUMBERING SYSTEM

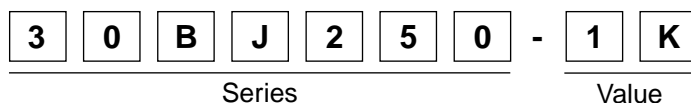

SERIES, WATTAGE, RANGE OF VALUES, TOLERANCE, VOLTAGE, AND DIMENSIONS

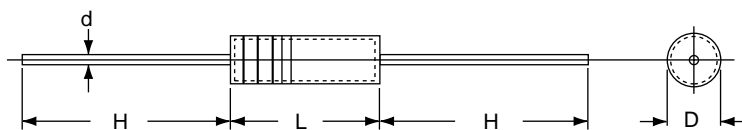

Series	Watts	Standard Range of Values (Ω)	Resistance Tolerance	Voltage (V) (max.)			Dimensions (mm)			
				Working	Overload	Pulse	L	D	H	d
30BJ250	1/4	2.2~22M	±5%	250	400	500	6.4	2.3	27.0±3	0.6
30BJ500	1/2	2.2~22M	±5%	350	700	700	9.5	3.5	27.0±3	0.74
30BJ901	1	2.2~200K	±10%	500	1,000	1,000	14.3	5.7	27.0±3	0.92

STANDARD STOCKED VALUES (Ω)

2.2	4.3	8.2	16	33	62	120	240	470	910	1.8K	3.6K	6.8K	13K	27K	51K	100K	200K	390K	750K	2.2M	6.8M
2.4	4.7	9.1	18	36	68	130	270	510	1.0K	2.0K	3.9K	7.5K	15K	30K	56K	110K	220K	430K	820K	2.4M	8.2M
2.7	5.1	10	20	39	75	150	300	560	1.1K	2.2K	4.3K	8.2K	16K	33K	62K	120K	240K	470K	910K	2.7M	
3.0	5.6	11	22	43	82	160	330	620	1.2K	2.4K	4.7K	9.1K	18K	36K	68K	130K	270K	510K	1.0M	3.3M	
3.3	6.2	12	24	47	91	180	360	680	1.3K	2.7K	5.1K	10K	20K	39K	75K	150K	300K	560K	1.2M	3.9M	
3.6	6.8	13	27	51	100	200	390	750	1.5K	3.0K	5.6K	11K	22K	43K	82K	160K	330K	620K	1.5M	4.7M	
3.9	7.5	15	30	56	110	220	430	820	1.6K	3.3K	6.2K	12K	24K	47K	91K	180K	360K	680K	1.8M	5.6M	

■ SURGE RESISTANCE CHARACTERISTICS

Charging and Discharging a 2,000 pF Condenser for 100 Cycles.

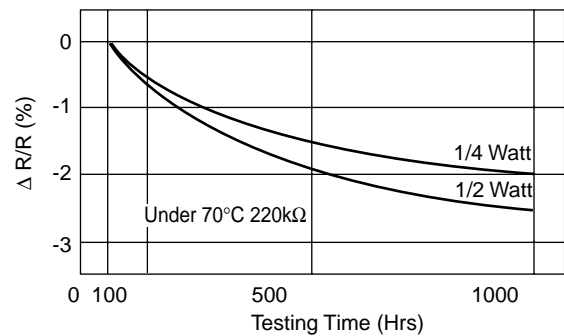
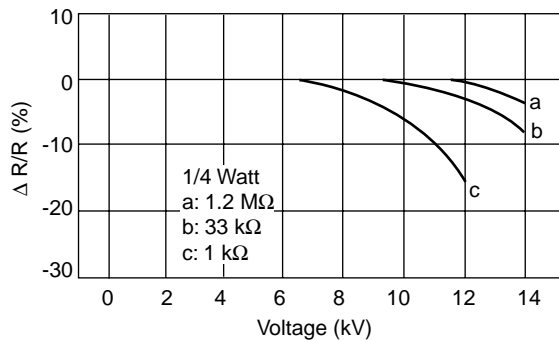

■ RELATIONSHIP BETWEEN LOAD RATIO AND AMBIENT TEMPERATURE

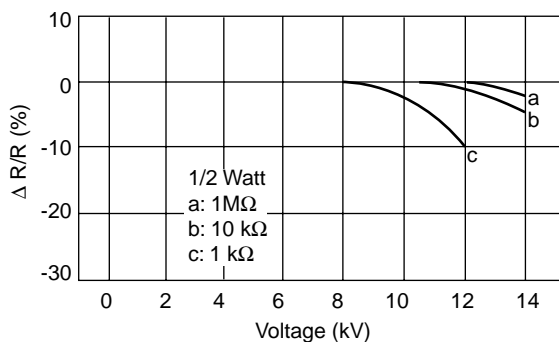

■ LOAD LIFE (RATED LOAD)

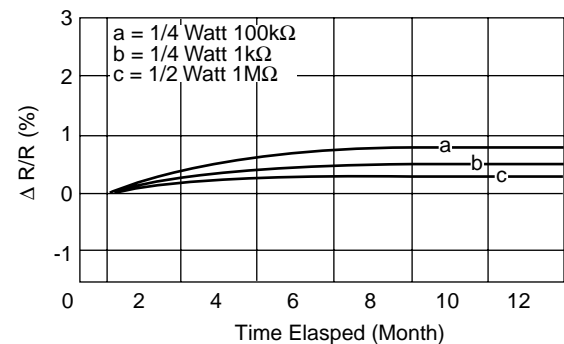

■ VARIATION WITH TIME

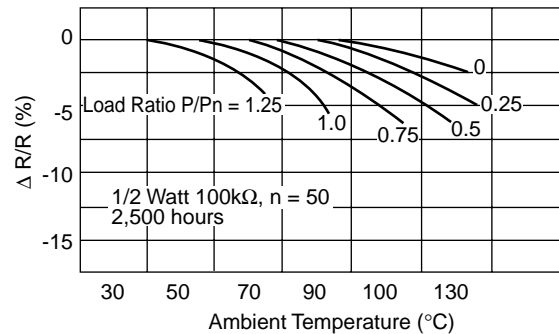

■ FREQUENCY CHARACTERISTICS

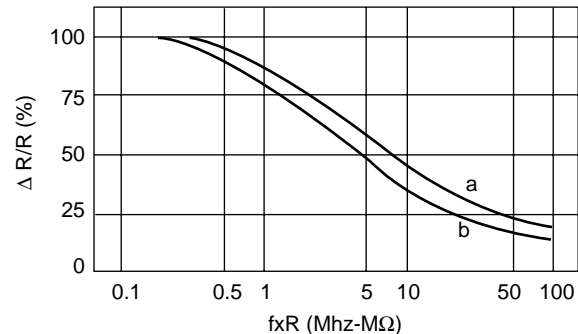

■ RELIABILITY TEST

Load Life in Moisture

Samples: 1/4 Watt, 100Ω, 1kΩ, 10kΩ, 100kΩ, 150 pieces of each, 600 pieces in total.

Conditions: 40°C in 95% RH 1% hours "ON" and 0.5 hours "OFF" cycling for 5,000 hours with DC voltage given by the following ratios:

Criterion (%)	Load Ratio P/Pn (%)	Total Testing Time T(Hrs)	Number of Failures r (pcs)	Failure Ratio		Average Lifetime (60% reliability level) (Hrs)	
				λ	λ CL (60%)		
$\Delta R/R$	± 5	0	2.984×10^6	6	0.201	0.244	4.098×10^5
		20	2.990×10^6	4	0.134	0.176	5.682×10^5
		60	2.997×10^6	2	0.067	0.104	9.615×10^5
		100	2.992×10^6	3	0.100	0.139	7.194×10^5
		Total	1.196×10^7	15	0.125	0.138	7.209×10^5
	± 10	Total	1.20×10^7	0	0.0055	0.0077	1.299×10^7



LEAD TAPING (SIZE IN mm)

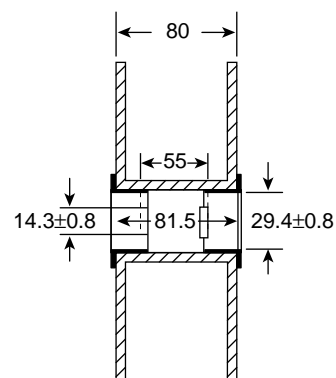
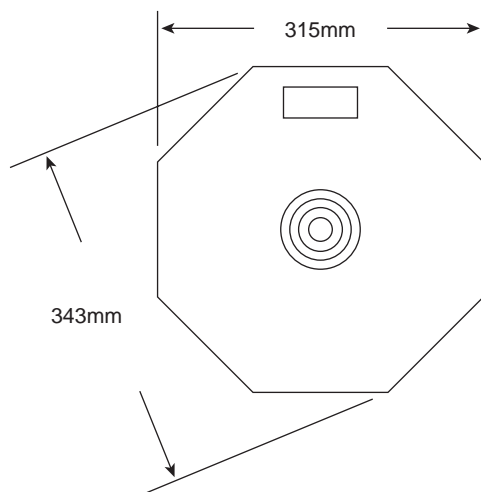
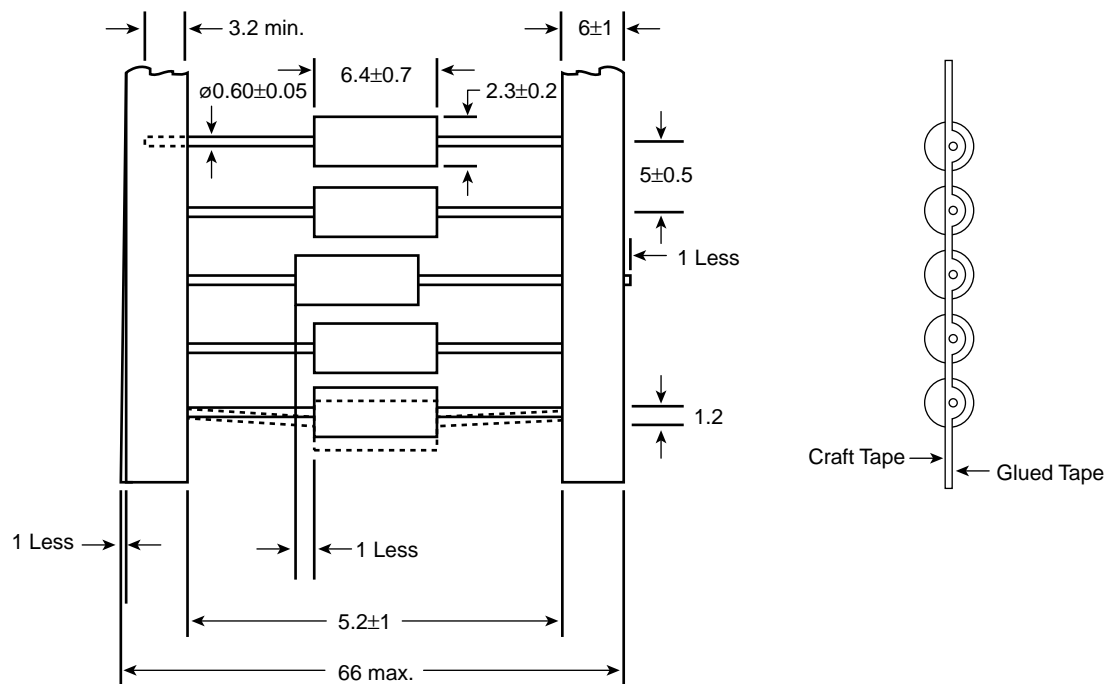

FEATURES

- ±5% tolerance
- Excellent flame retardant coating
- Stable performance in diverse environments
- High purity ceramic core
- Meets EIAJ-RC2655A requirements
- Other values may be available on request

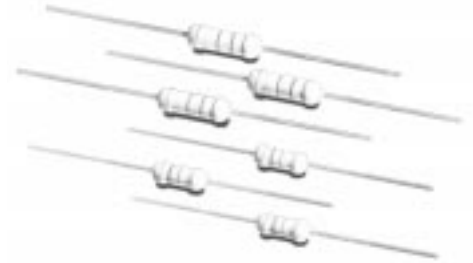

CHARACTERISTICS

Item	Characteristics
Operating Temperature Range	-55°C ~ +240°C (derated over 70°C)
Temperature Coefficient	±350ppm/°C
Short Time Overload	±(1% +0.05Ω)
Temperature Cycling	±(1% +0.05Ω)
Soldering Effect	±(1% +0.05Ω)
Vibration	±(1% +0.05Ω)
Moisture Resistance	±(5% +0.10Ω)
Load Life (1,000 hrs., 70°C)	±(5% +0.05Ω)

DERATING CURVE

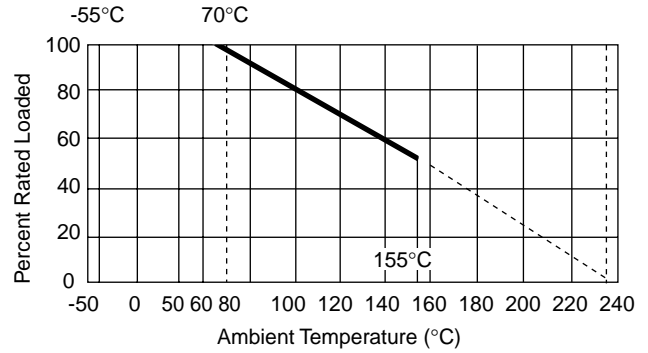

PART NUMBERING SYSTEM

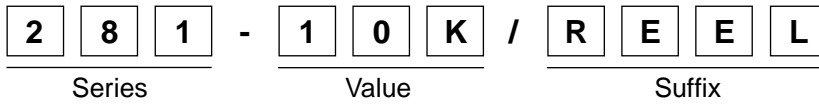

Suffix Code:	Package:
(blank)	Bulk
REEL	Tape and Reel
AP	Ammo Pack

SERIES, SIZE, WATTAGE, RANGE OF VALUES, VOLTAGE, AND DIMENSIONS

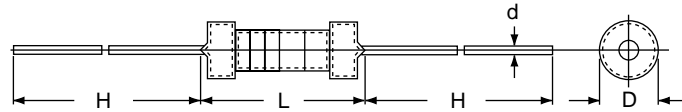

Series	Case Size	Watts (W)	Standard Range of Values	Voltage (V) (max.) @ 70°C			Dimensions (mm)			
				Working	Overload	Withstanding	L (max.)	D (max.)	H ±3	d +.02, -.05
281	Small	1	0.1 ~ 1.0M	350	600	350	10	4	28	0.7
282	Small	2	0.1 ~ 1.0M	350	600	350	12	5	28	0.7
283	Small	3	0.1 ~ 1.0M	500	800	500	16	5.5	28	0.8
286	Small	5	0.22 ~ 560K	500	800	500	25	8	38	0.8
261	Standard	1	0.1 ~ 1.0M	350	600	350	12	5	28	0.7
262	Standard	2	0.1 ~ 1.0M	350	600	350	16	5.5	28	0.8
307	Standard	3	0.1 ~ 1.0M	500	800	500	17.5	6.5	28	0.8
308	Standard	5	0.22 ~ 150K	750	1,000	500	26	8.5	38	0.8
309	Standard	7	20 ~ 150K	750	1,000	750	32	8.5	38	0.8

STANDARD STOCKED VALUES (Ω)

0.47	0.82	1.6	3.3	6.2	12	24	47	91	180	360	680	1.3K	2.7K	5.1K	10K	20K	39K	75K	150K	300K	560K
0.5	0.91	1.8	3.6	6.8	13	27	51	100	200	390	750	1.5K	3.0K	5.6K	11K	22K	43K	82K	160K	330K	620K
0.51	1.0	2.0	3.9	7.5	15	30	56	110	220	430	820	1.6K	3.3K	6.2K	12K	24K	47K	91K	180K	360K	680K
0.56	1.1	2.2	4.3	8.2	16	33	62	120	240	470	910	1.8K	3.6K	6.8K	13K	27K	51K	100K	200K	390K	750K
0.62	1.2	2.4	4.7	9.1	18	36	68	130	270	510	1.0K	2.0K	3.9K	7.5K	15K	30K	56K	110K	220K	430K	820K
0.68	1.3	2.7	5.1	10	20	39	75	150	300	560	1.1K	2.2K	4.3K	8.2K	16K	33K	62K	120K	240K	470K	910K
0.75	1.5	3.0	5.6	11	22	43	82	160	330	620	1.2K	2.4K	4.7K	9.1K	18K	36K	68K	130K	270K	510K	1.0M



■ DIMENSIONS (mm), AMMO PACK AND TAPE AND REEL

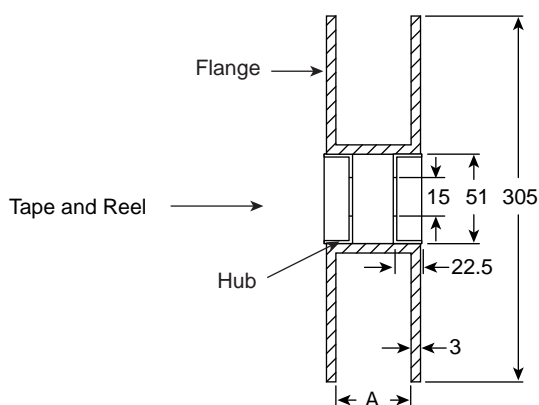
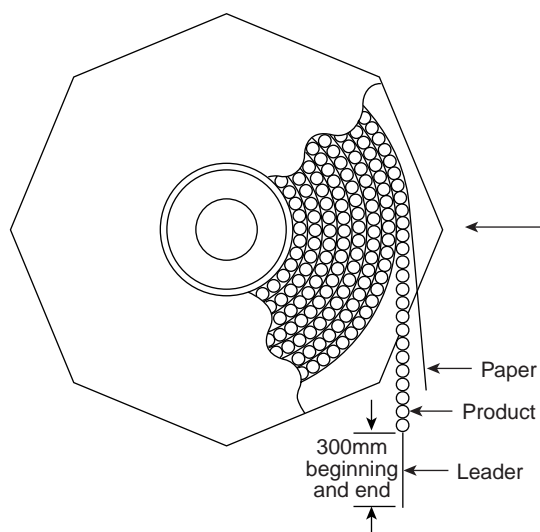
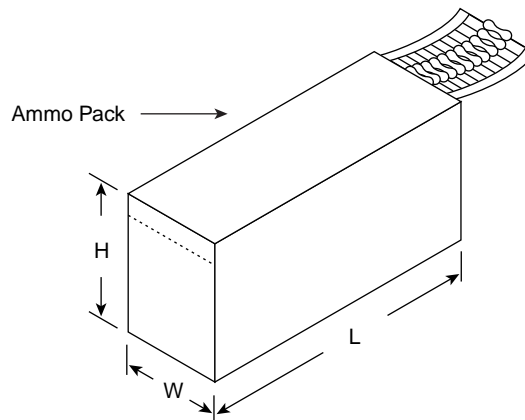
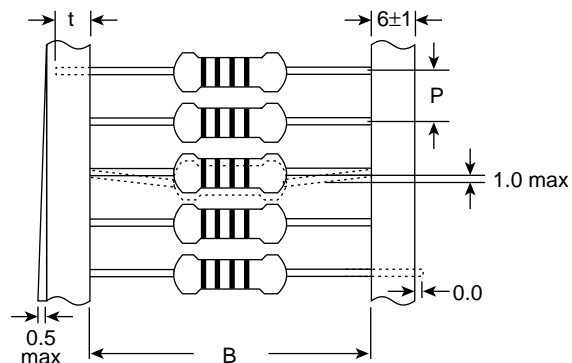

Series	Case Size	Dimensions (mm)			Quantity Per Box	Ammo Pack			Reel	
		B	P	t		Dimensions (mm)			Quantity Per Reel	Dim. (mm)
						L	W	H		
281	Small	52	5	4	1000	260	85	70	2500	73
282	Small	58	5	4	1000	262	86	80	2500	73
283	Small	58	5	4	1000	262	86	80	1000	73
286	Small	---	---	---	---	---	---	---	---	---
261	Standard	64	10	5	1000	262	92	108	2500	81
262	Standard	64	10	5	1000	262	92	108	1000	81
307	Standard	64	10	5	500	256	92	80	500	81
308	Standard	---	---	---	---	---	---	---	---	---
309	Standard	---	---	---	---	---	---	---	---	---

FEATURES

- Miniature, high density packaging
- Combinations of different ohmic value are available
- High reliability with RuO₂ paste
- Recommended wash method is alcohol



CHARACTERISTICS

Items	Characteristics
Operating Temperature Range	-55°C ~ +125°C
Temperature Coefficient Range	±100ppm: 50Ω ~ 1.0MΩ, ±250ppm: <50Ω or >1.0MΩ
Rating Ambient Temperature	+70°C
Standard Resistance Range	10Ω - 1.0MΩ
Wattage/Element	1/8W
Max. Working Voltage	100V
Resistance Tolerance	2%
Lead Material	Steel alloy and weldable

DERATING CURVE

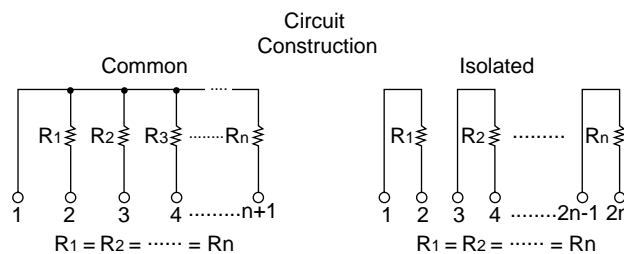
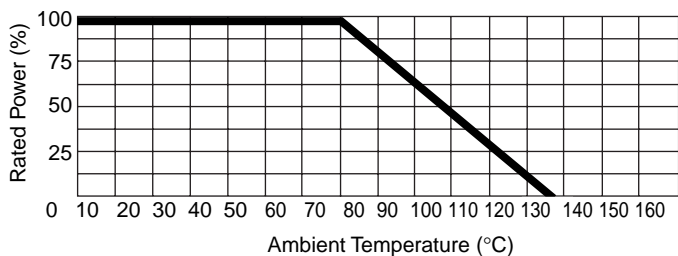

PART NUMBERING SYSTEM

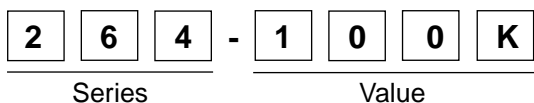

DIMENSIONS

Series		Number of Pins	L max. (mm)
Comm.	Isol.		
264	267	6	15.3
265	268	8	20.4
266	269	10	25.4

4 ~ 14 pin configurations available special order.

Dimensions (mm)

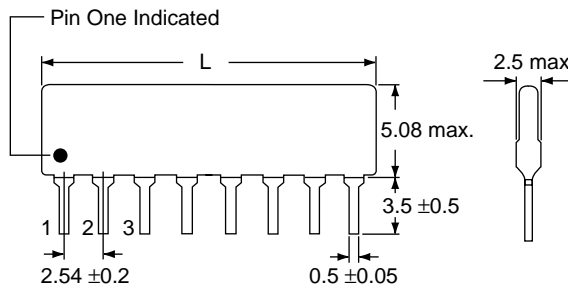

STANDARD STOCKED VALUES (Ω)

10	51	150	470	1.2K	3.3K	8.2K	22K	68K	220K	680K
22	56	180	510	1.5K	3.9K	10K	27K	82K	270K	820K
27	68	220	560	1.8K	4.7K	12K	33K	100K	330K	1M
33	82	270	680	2K	5.1K	15K	39K	120K	390K	
39	100	330	820	2.2K	5.6K	18K	47K	150K	470K	
47	120	390	1K	2.7K	6.8K	20K	56K	180K	560K	



FEATURES

- 5% tolerance
- Exceptionally small, sturdy, and reliable
- Sealed with a special cement
- Excellent moisture resistance
- High temperature stability
- Ceramic flame retardant package
- Recommended wash method is alcohol

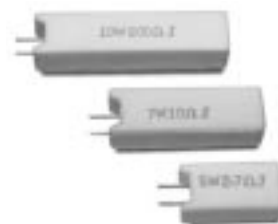

CHARACTERISTICS

Items	Characteristics
Wet Load Life	$\pm(5\% +0.05\Omega)$
Load Life	$\pm(5\% +0.05\Omega)$
Short Time Overload	$\pm(5\% +0.05\Omega)$
Temperature Coefficient	$\geq 20\Omega$ is $\pm 350\text{ppm}/^\circ\text{C}$ max.; $< 20\Omega$ is $\pm 400\text{ppm}/^\circ\text{C}$
Effect of Soldering	$\pm(1\% +0.05\Omega)$

DERATING CHART

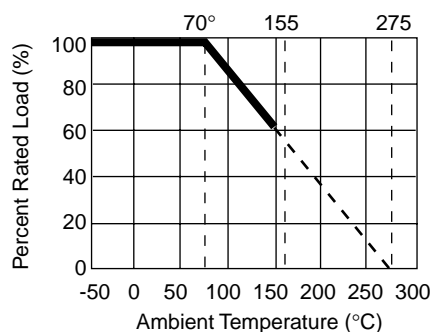

HEAT RISE CHART

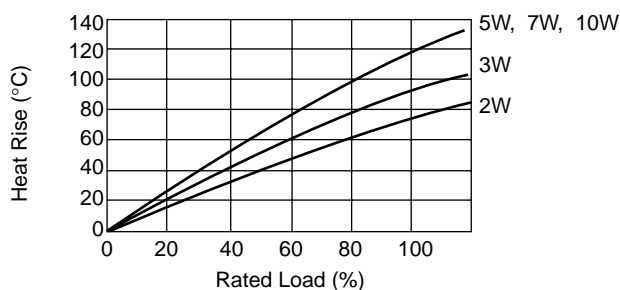

PART NUMBERING SYSTEM

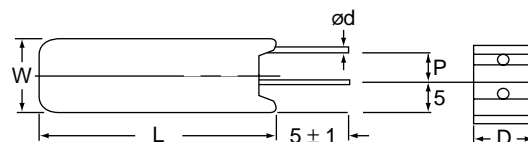

SERIES, WATTAGE, VALUE RANGE, AND DIMENSIONS

Series	Watts (W)	Range of Values (Ω)		Dimensions (mm)				
		Wirewound	Power Film	W ± 1	D ± 1	L ± 1	$\phi d +.02 -.05$	P ± 1
* PRM	2	0.1 ~ 27	28 ~ 33K	11.5	7.5	20	0.6	5
* PRM	3	0.1 ~ 39	40 ~ 56K	12.5	8.5	25	0.7	5
* PRM	5	0.1 ~ 47	48 ~ 100K	12.5	9	25	0.8	5
PRM	7	0.1 ~ 680	681 ~ 200K	12.5	9	38	0.8	5
PRM	10	0.1 ~ 910	911 ~ 200K	12.5	9	50	0.8	5
PRMA	5	0.1 ~ 47	48 ~ 100K	12.5	9	25	0.8	7.5
PRMA	10	0.1 ~ 560	561 ~ 100K	16	12	35	0.8	7.5

* Leads are centered

STANDARD STOCKED VALUES (Ω)

All standard E-24 values not listed are available special order.

0.1	0.3	0.51	1.0	3.0	6.8	15	33	56	68	75	100	150	200	300	330	470	680	1K	2K	4.7K	10K
0.22	0.47	0.68	2.2	4.7	10	20	47														



FEATURES

- 5% tolerance
- Exceptionally small, sturdy, and reliable
- Sealed with a special cement
- Excellent moisture resistance
- High temperature stability
- Ceramic flame retardant package

CHARACTERISTICS

Items	Characteristics
Wet Load Life	$\pm(5\% +0.05\Omega)$
Load Life	$\pm(5\% +0.05\Omega)$
Short Time Overload	$\pm(5\% +0.05\Omega)$
Temperature Coefficient	$\geq 20\Omega$ is $\pm 350\text{ppm}/^\circ\text{C}$ max.; $< 20\Omega$ is $\pm 400\text{ppm}/^\circ\text{C}$
Effect of Soldering	$\pm(1\% +0.05\Omega)$

HEAT RISE CHART

DIMENSIONS (mm)

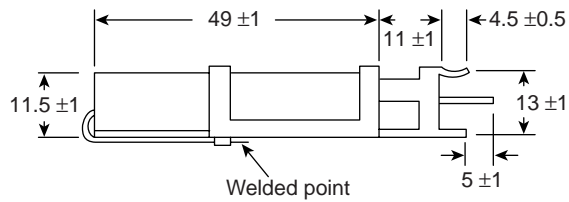
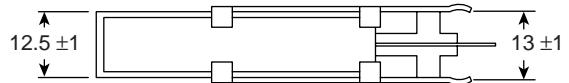

PART NUMBERING SYSTEM

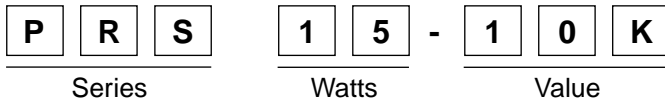

SERIES, WATTAGE, VALUE RANGE, AND DIMENSIONS

Series	Watts (W)	Range of Values (Ω)		Dimensions (mm)				
		Wirewound	Power Film	$W \pm 1$	$D \pm 1$	$L \pm 1$	$\text{od} +.02 -.05$	$P \pm 1$
PRS	15	0.1 ~ 27	28 ~ 1K	12.5	11.5	49.0	0.6	11.0

FEATURES

- 5% tolerance
- Exceptionally small, sturdy, and reliable
- Sealed with a special cement
- Excellent moisture resistance
- High temperature stability
- Ceramic flame retardant package
- Recommended wash method is alcohol



CHARACTERISTICS

Item	Characteristics
Operating Temperature Range	-55°C ~ +155°C
Temperature Coefficient	≥20Ω is ±350ppm/°C max., <20Ω is ±400ppm/°C Test methods: natural resistance change per temp. °C; $[R_2 - R_1 / R_1 (t_2 - t_1)] \times 10^6$ (ppm/°C); R ₁ is resis. value at room temp. (t ₁); R ₂ is resis. value at room temp.+100°C (t ₂); Test pattern is room temp., room temp.+100°C.
Dielectric Withstanding Voltage	No evidence of flashover mechanical damage, arcing or insulation breakdown. Test method is resistors are clamped in the trough of a 90° metallic V-block and tested at 500V for 60 +10/-0 seconds.
Temperature Cycling	±(2% +0.05Ω) max. with no evidence of mechanical damage. Test method is five cycles for duty cycle as follows: step 1 at -55°C ±3°C for 30 min.; step 2 at room temp. for 10~15 min.; step 3 at +155°C ±2°C for 30 min.; step 4 at room temp. for 10~15 min.
Short-Time Overload (permanent resistance change)	±(5% +0.05Ω) max. with no evidence of mechanical damage. Test method is the application of a potential of 2.5 times RCWV for 5 seconds.
Humidity (steady rate) (temporary resistance change)	±(5% +0.05Ω) max. with no evidence of mechanical damage. Test method is 1,000 hours (240 hours on 25W) exposure in a humidity test chamber controlled at 40°C ±2°C and 90~95% relative humidity.
Load Life in Humidity	±(5% +0.05Ω) max. with no evidence of mechanical damage. Test method is 1,000 hours operating at RCWV with duty cycle of 1.5 hours "on", 0.5 hour "off" in a humidity test chamber controlled at 40°C ±2°C and 90~95% relative humidity. RCWV = square root of PR; P = power rating, R = resistance (Ω).
Load Life (permanent resistance change)	±(5% +0.05Ω) max. with no evidence of mechanical damage. Test method is 1,000 hours operating at RCWV with duty cycle of 1.5 hours "on", 0.5 hour "off" at +70°C ±2°C ambient.
Terminal Strength	No evidence of mechanical damage. Test methods as follows: Direct Load; resistance to a 2.5kg direct load for 10 seconds in direction of longitudinal axis of the terminal leads. Twist Test; terminal leads are bent through 90° at a point of about 6mm from the body of the resistor and are rotated through 360° about the original axis of the bent terminal in alternating direction for a total of 3 rotations.
Solderability	95% coverage min. Test method is that the area is covered with a new, smooth, clean, shiny and continuous surface free from concentrated pinholes. Test temperature of solder is +235°C ±5°C. Time in solder is 3 +.5/-0 seconds.
Resistance to Soldering Heat	±(1% +0.05Ω) max. with no evidence of mechanical damage. Test method is that the leads are immersed to 3.2~4.8mm from the body in +350°C ±10°C solder for 3 ±0.5 seconds.

HEAT RISE CHART

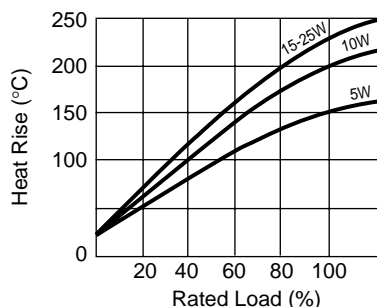

DERATING CURVE

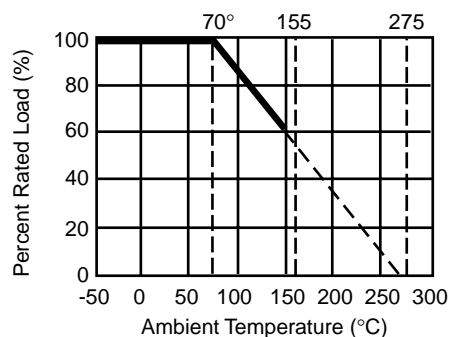

PART NUMBERING SYSTEM

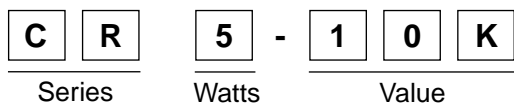

POWER RATING, RANGE OF VALUES, AND DIMENSIONS

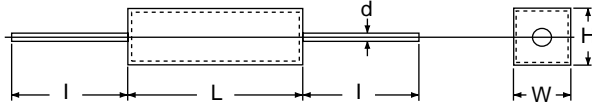

Watts (W)	Range of Values		Dimensions (mm)				
	Wire Wound	Metal Oxide	$L \pm 1$	$W \pm 1$	$H \pm 1$	$I \pm 5$	$d +.02 -.05$
5	0.1 ~ 47	48 ~ 50K	22	10	9	35	0.8
10	0.1 ~ 910	911 ~ 50K	49	10	9	35	0.8
15	1 ~ 1K	1.1K ~ 150K	49	12.5	11.5	35	0.8
25	2 ~ 1.2K	-- N/A --	64	14.5	13.5	34	0.8

STANDARD STOCKED VALUES (Ω)

0.1	0.33	0.56	1.0	1.8	3.3	4.7	6.8	11	18	27	43	62	100	160	250	390	560	910	1.5K	2.4K	4.7K
0.15	0.39	0.62	1.1	2.0	3.6	5.0	7.5	12	20	30	47	68	110	180	270	430	620	1.0K	1.6K	2.7K	5.0K
0.2	0.43	0.68	1.2	2.2	3.9	5.1	8.2	13	22	33	50	75	120	200	300	470	680	1.1K	1.8K	3.0K	10K
0.22	0.47	0.75	1.3	2.4	4.0	5.6	9.1	15	24	36	51	82	130	220	330	500	750	1.2K	2.0K	3.3K	20K
0.27	0.5	0.82	1.5	2.7	4.3	6.2	10	16	25	39	56	91	150	240	360	510	820	1.3K	2.2K	3.9K	25K
0.3	0.51	0.91	1.6	3.0																	

FEATURES

- 5% tolerance
- Exceptionally small, sturdy, and reliable
- Sealed with a special cement
- Excellent moisture resistance
- High temperature stability
- Ceramic flame retardant package
- Recommended wash method is alcohol

CHARACTERISTICS

Item	Characteristics
Operating Temperature Range	-55°C ~ +155°C
Temperature Coefficient	≥20Ω is ±350ppm/°C max., <20Ω is ±400ppm/°C Test methods: natural resistance change per temp. °C; $[R_2 - R_1 / R_1(t_2 - t_1)] \times 10^6$ (ppm/°C); R ₁ is resis. value at room temp. (t ₁); R ₂ is resis. value at room temp.+100°C (t ₂); Test pattern is room temp., room temp.+100°C.
Dielectric Withstanding Voltage	No evidence of flashover mechanical damage, arcing or insulation breakdown. Test method is resistors are clamped in the trough of a 90° metallic V-block and tested at 500V for 60 +10/-0 seconds.
Temperature Cycling	±(2% +0.05Ω) max. with no evidence of mechanical damage. Test method is five cycles for duty cycle as follows: step 1 at -55°C ±3°C for 30 min.; step 2 at room temp. for 10~15 min.; step 3 at +155°C ±2°C for 30 min.; step 4 at room temp. for 10~15 min.
Short-Time Overload (permanent resistance change)	±(5% +0.05Ω) max. with no evidence of mechanical damage. Test method is the application of a potential of 2.5 times RCWV for 5 seconds.
Humidity (steady rate) (temporary resistance change)	±(5% +0.05Ω) max. with no evidence of mechanical damage. Test method is 1,000 hours (240 hours on 25W) exposure in a humidity test chamber controlled at 40°C ±2°C and 90~95% relative humidity.
Load Life in Humidity	±(5% +0.05Ω) max. with no evidence of mechanical damage. Test method is 1,000 hours operating at RCWV with duty cycle of 1.5 hours "on", 0.5 hour "off" in a humidity test chamber controlled at 40°C ±2°C and 90~95% relative humidity. RCWV = square root of PR; P = power rating, R = resistance (Ω).
Load Life (permanent resistance change)	±(5% +0.05Ω) max. with no evidence of mechanical damage. Test method is 1,000 hours operating at RCWV with duty cycle of 1.5 hours "on", 0.5 hour "off" at +70°C ±2°C ambient.
Terminal Strength	No evidence of mechanical damage. Test methods as follows: Direct Load; resistance to a 2.5kg direct load for 10 seconds in direction of longitudinal axis of the terminal leads. Twist Test; terminal leads are bent through 90° at a point of about 6mm from the body of the resistor and are rotated through 360° about the original axis of the bent terminal in alternating direction for a total of 3 rotations.
Solderability	95% coverage min. Test method is that the area is covered with a new, smooth, clean, shiny and continuous surface free from concentrated pinholes. Test temperature of solder is +235°C ±5°C. Time in solder is 3 +.5/-0 seconds.
Resistance to Soldering Heat	±(1% +0.05Ω) max. with no evidence of mechanical damage. Test method is that the leads are immersed to 3.2~4.8mm from the body in +350°C ±10°C solder for 3 ±0.5 seconds.

HEAT RISE CHART

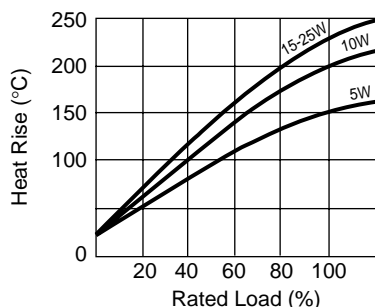

DERATING CURVE

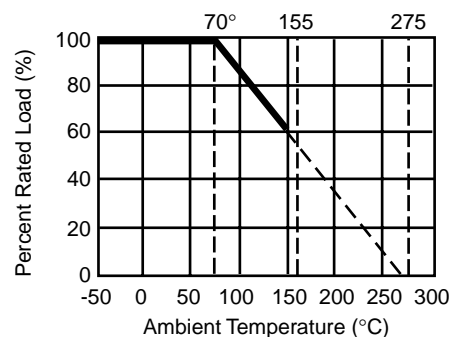

PART NUMBERING SYSTEM

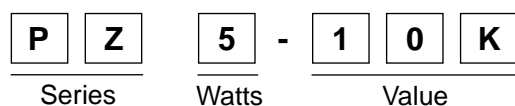

■ POWER RATING, RANGE OF VALUES, AND DIMENSIONS

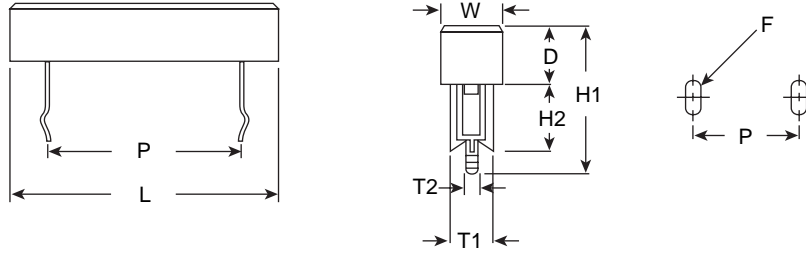

Watts (W)	Dimensions (mm)								
	L ±1	W ±1	D ±1	T1 ±5	T2 ±0.2	H1 +2/-1	H2 +2/-1	P	F
5	27	10	9	7	1.6	39	25	15	0.8 x 2
10	48	10	9	7	1.6	39	25	35	0.8 x 2
15	48	12.5	11.5	10	3	47	30	32	1 x 3.5
25	63	12.5	11.5	10	3	47	30	45	1 x 3.5

FEATURES

- Designed for heat sink mounting
- Low values, down to .005Ω
- Solder, cable, threaded, or fast-on terminations
- Inductive or low inductance
- Manufacturing approved to ISO 9001 (1994)



CHARACTERISTICS

Item	Characteristics
Tolerance	±1%, ±5% and ±10%, other tolerances available upon special request, ask for details
Tolerance for Low Ω Values	≤.047 is ±10%; ≥.05 is ±5%
Insulation Resistance	10,000MΩ min
Temperature Coefficients	<1Ω is 100ppm/°C; 1Ω ~ 50Ω is 50ppm/°C; >50Ω is 25ppm/°C
Power Dissipation	@ high ambient temperature: dissipation derates linearly to zero at 200°C
Core	Ceramic-steatite or alumina depending on size
Element	Copper nickel alloy or nickel chrome alloy
End caps	Nickel iron or stainless steel
Encapsulant	High temperature molding compound
Housing	Anodized aluminum
Terminals	10W ~ 150W is silver plated steel cored copper; 200W ~ 300W is brass, stainless steel or copper clad steel

PART NUMBERING SYSTEM

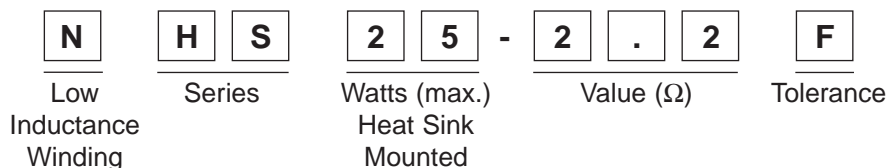

Tolerance Code:
F = ±1%
J = ±5%
K = ±10%

TEMPERATURE RISE AND POWER DISSIPATION

Surface Temperature of resistor related to power dissipation. The resistor is standard heat sink mounted using a proprietary heat sink compound.

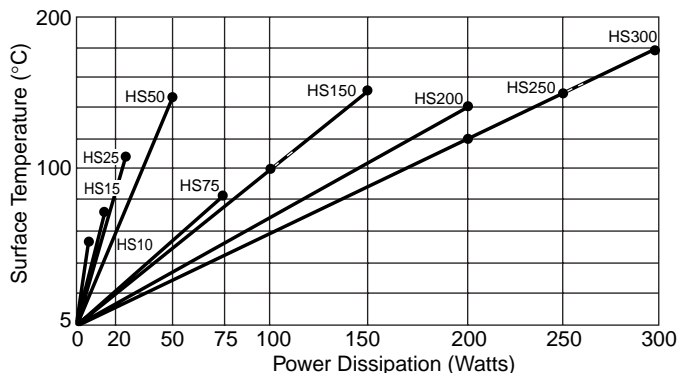

APPLICATION NOTES

The ARCOL HS style is a range of high quality, high stability aluminum housed power wirewound resistors designed for direct heat sink attachment. The resistive element is wound onto high thermal conductivity ceramic formers ground to a close tolerance finish ensuring maximum contact for rapid heat transfer. This element is encapsulated in the aluminum housing by a transfer molding process which ensures a good humidity seal and a permanent compression fit. The encapsulant is a high temperature molding compound and the special ARCOL mold tool design ensures accurate concentricity of the resistive element inside the housing giving a high level of voltage protection. Our engineers have 30 years experience in the design and manufacture of this style of resistor and during this period we have produced many different HS types to meet customers special requirements. If you need a special design for your application, be it high voltage, short term overload, special mounting or terminations then please contact us for advice.

Heat Dissipation

While the use of proprietary heat sinks with lower thermal resistance is acceptable, uprating is not recommended. For maximum heat transfer, it is recommended that a heat sink compound be applied between the resistor base and heat sink/chassis mounting surface. It is essential that the maximum hot spot temperature of 200° is not exceeded and therefore the resistor must be mounted on a heat sink of correct thermal resistance for the power being dissipated.

Maximum Overload

Please consult the factory for assistance concerning your particular overload application. Further information concerning the internal resistance characteristics of each HS resistor is available on request.



■ ELECTRICAL SPECIFICATIONS

Watts (max.) Heat Sink Mounted	Watts @25°C Without Heat Sink	Resistance Range (Ω)	Maximum Working Voltage (DC/ACrms)	Dielectric Strength AC Peak	Stability ΔR% Per 1000 Hours	Maximum Weight (grams)	Surface Temp. Rise °C/Watt Std. Heat Sink Mounted	Standard Heat Sink (Aluminum)		Style MIL-R 18546
								Area CM ²	Thick. (mm)	
10	5.5	.005 ~ 5K	160	1000	1	4	5.8	415	1	RE60
15	8	.005 ~ 10K	265	1000	1	7	5.1	415	1	RE65
25	12.5	.01 ~ 25K	550	2500	1	14	4.2	535	1	RE70
50	20	.01 ~ 50K	1250	2500	1	32	3.0	535	1	RE75
75	45	.1 ~ 50K	1400	5000	2	85	1.1	995	3	---
100	50	.1 ~ 70K	1900	5000	2	115	1.0	995	3	---
150	55	.1 ~ 100K	2500	5000	2	175	1.0	995	3	---
200	50	.1 ~ 39K	1900	5000	3	475	0.7	3750	3	---
250	60	.1 ~ 51K	2200	5000	3	600	0.6	4765	3	---
300	75	.1 ~ 63K	2500	5000	3	700	0.6	5780	3	---

■ DIMENSIONS

Center hole in each flange is in 150 Watts only.

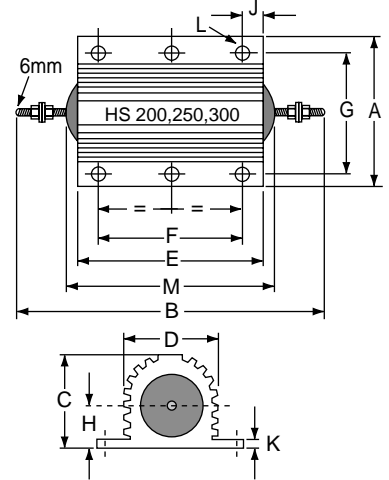
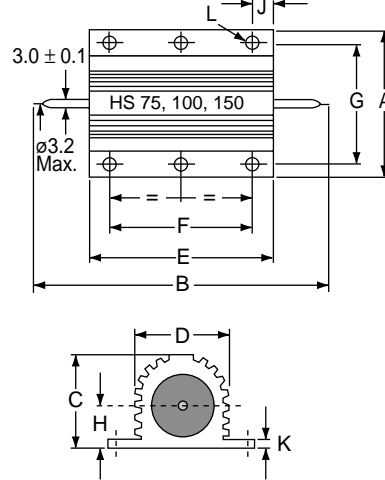
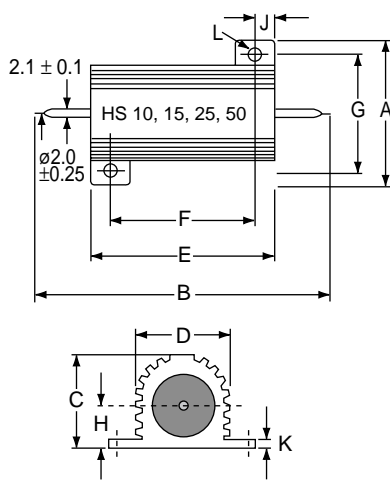

Watts (max.) Heat Sink Mounted	Dimensions (mm)											
	A max.	B max.	C max.	D ±1.6	E max.	F ±0.3	G ±0.3	H ±0.5	J ±0.4	K ±0.8	L ±0.25 †	M max.
10	17.0	30.0	9.0	8.5	17.0	11.3	12.4	4.0	2.0	1.7	2.4	---
15	21.0	36.5	11.0	11.2	21.0	14.3	15.9	5.2	2.4	1.7	2.4	---
25	28.0	51.0	15.0	13.5	29.0	18.3	19.8	7.2	4.3	2.4	3.2	---
50	30.0	72.5	17.0	15.1	51.0	39.7	21.4	7.9	4.8	2.4	3.2	---
75	48.0	72.0	26.0	27.0	49.0	29.0	37.0	11.5	10.0	3.5	4.4	---
100	48.0	88.0	26.0	27.0	65.5	35.0	37.0	11.5	15.0	3.5	4.4	---
150	48.0	122.0	26.0	27.0	98.0	58.0	37.0	11.5	20.0	3.5	4.4	---
200	73.0	146.0	45.0	46.0	90.0	70.0	57.2	20.0	10.0	5.0	5.1	106.0
250	73.0	157.0	45.0	46.0	109.0	89.0	57.2	20.0	10.0	5.0	5.1	125.0
300	73.0	185.0	45.0	46.0	128.0	104.0	59.0	20.0	12.0	5.0	6.6	144.0

† 200 ~ 300 Watts is ±.45

■ STANDARD STOCKED VALUES (Ω)

0.1	0.27	0.5	0.68	1.5	2.7	4.0	7.5	20	27	40	56	100	150	220	330	500	1K	2K	3.3K	10K	25K
0.15	0.33	0.51	0.82	2.0	3.0	4.7	10	22	30	47	68	120	200	250	470	680	1.5K	3K	5K	20K	50K
0.22	0.47	0.56	1.0	2.2	3.3	5.0	15	25	33	50	75										

150W ~ 300W are made to order.



FEATURES

- Designed for heat sink mounting
- Non-inductive construction
- Solder, cable, threaded, or fast-on terminations
- Usable as audio and RF dummy loads
- Manufacturing approved to ISO 9001 (1994)



CHARACTERISTICS

Item	Characteristics
Tolerance	±1%, ±5% and ±10%, other tolerances available upon special request, ask for details
Tolerance for Low Ω Values	≤.047 is ±10%; ≥.05 is ±5%
Insulation Resistance	10,000MΩ min
Temperature Coefficients	<1Ω is 100ppm/°C; 1Ω ~ 50Ω is 50ppm/°C; >50Ω is 25ppm/°C
Power Dissipation	@ high ambient temperature: dissipation derates linearly to zero at 200°C
Core	Ceramic-steatite or alumina depending on size
Element	Copper nickel alloy or nickel chrome alloy
End caps	Nickel iron or stainless steel
Encapsulant	High temperature molding compound
Housing	Anodized aluminum
Terminals	100W is silver plated steel cored copper; 200W ~ 300W is brass, stainless steel or copper clad steel
Power Rating	Nominal rating: 1 minute on, 4 minutes off. Continuous rating: rated power @ 50%.

PART NUMBERING SYSTEM

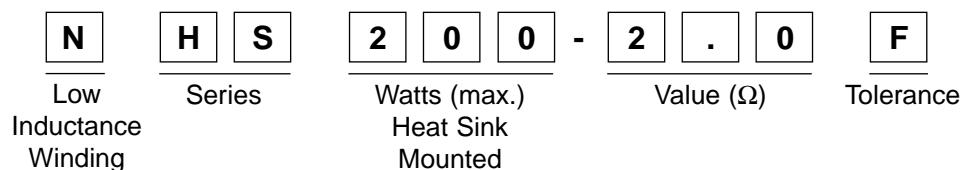

Tolerance Code:
F = ±1%
J = ±5%
K = ±10%

ELECTRICAL SPECIFICATIONS and STANDARD STOCKED VALUES (Ω)

Watts (max.) Heat Sink Mounted	Watts @25°C Without Heat Sink	Resistance Range (Ω)	Maximum Working Voltage (DC/ACrms)	Dielectric Strength AC Peak	Stability ΔR% Per 1000 Hours	Maximum Weight (grams)	Surface Temp. Rise °C/Watt Std. Heat Sink Mounted	Standard Heat Sink (Aluminum)		Stocked Values
								Area CM ²	Thick. (mm)	
100	50	.1 ~ 70K	1900	5000	2	115	1.0	995	3	2.0
200	50	.1 ~ 39K	1900	5000	3	475	0.7	3750	3	4.0
300	75	.1 ~ 63K	2500	5000	3	700	0.6	5780	3	8.0
										16.0
										50.0

DIMENSIONS

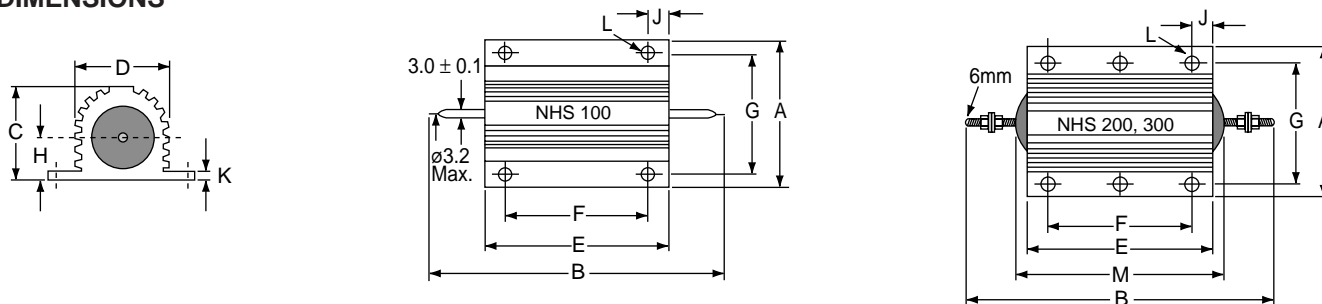

† 200 ~ 300 Watts is ±.45

Watts (max.) Heat Sink Mounted	Dimensions (mm)											
	A max.	B max.	C max.	D ±1.6	E max.	F ±0.3	G ±0.3	H ±0.5	J ±0.4	K ±0.8	L ±0.25 †	M max.
100	48.0	88.0	26.0	27.0	65.5	35.0	37.0	11.5	15.0	3.5	4.4	---
200	73.0	146.0	45.0	46.0	90.0	70.0	57.2	20.0	10.0	5.0	5.1	106.0
300	73.0	185.0	45.0	46.0	128.0	104.0	59.0	20.0	12.0	5.0	6.6	144.0



Zinc oxide varistor is a voltage dependent resistor with symmetrical voltage-current characteristics that is designed to protect all kinds of electronic devices or elements from switching and induced lightning surges.

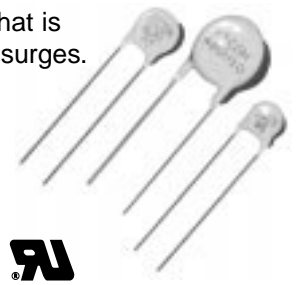

APPLICATIONS

- IC, diode, transistor, thyristor, triac, and other semiconductor protection
- Suppression of main-borne transients in consumer electronics and industrial electronics
- Suppression of internally-generated spikes in electronics circuits
- Surge protection in communication, measuring and controller electronics
- Surge protection in electronic home appliances and gas petroleum appliances
- Relay and semiconductor switch surge absorption

FEATURES

- Fast response time
- Low leakage current
- Excellent voltage ratio
- Wide voltage and energy ratio
- Low standby power and no follow-on current
- High performance in surge current handling capability
- High performance in clamping voltage characteristics

V-I Characteristic of Varistor
Current (mA)

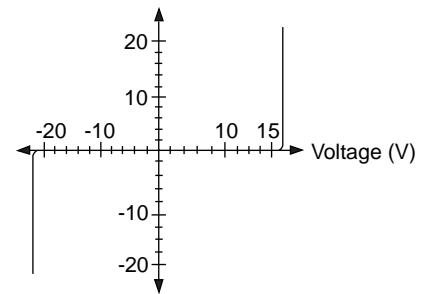

PART NUMBERING SYSTEM

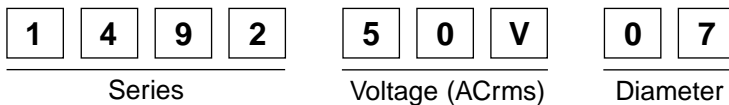

CHARACTERISTICS

The varistor's rest state has a high impedance (several megohms) in relation to the component to be protected and does not change the characteristics of the electric circuit. In the presence of transient voltage, (over the breakdown voltage of varistor) the varistor then has a low impedance (a few ohms) and short circuits the assembly E to be protected.

Surge suppression of varistor

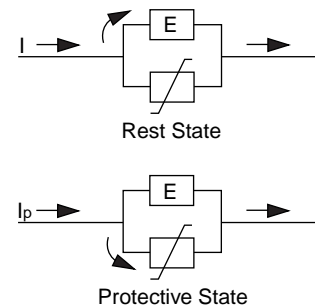
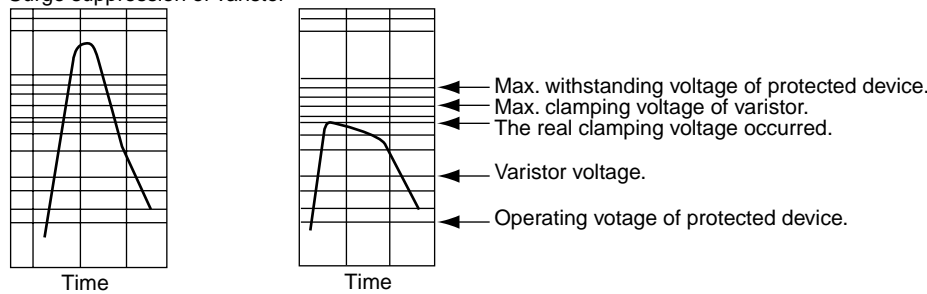

DIMENSIONS

Diameter (mm)	Dimensions (mm)						
	øD max.	ød	LS	H max.	T max.		
					≤50V	60~300V	350~680V
5	6.5	0.6	5.0	10.0	4.4	4.9	---
7	8.4	0.6	5.0	13	4.4	4.9	---
10	11.5	0.8	7.5	18	4.9	5.4	8.4
14	15.6	0.8	7.5	22	5.0	5.5	8.5
20	21.8	1.0	10	28	5.5	6.0	9.0

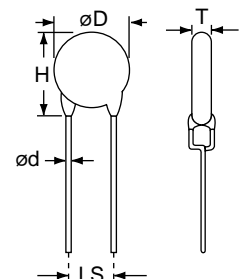

■ 5mm SPECIFICATIONS and PULSE LIFETIME RATINGS; RECTANGULAR WAVE (µsec.)

Maximum Allowable Voltage (V)		Varistor Voltage (V) 0.1mA		Max. Clamping Voltage Vc (V)	Withstd. Surge Current (A)	Rated Wattage (W)	Energy @2ms (J)	Typical Cap. @1KHz (pF)
ACrms	DC	V	Tol. (min.-max.)					
11	14	18	14.4 ~ 21.6	40	50	0.01	0.6	1050
14	18	22	18.7 ~ 26.0	48	50	0.01	0.7	950
17	22	27	23.0 ~ 31.1	60	50	0.01	0.9	870
20	26	33	29.5 ~ 36.5	73	50	0.01	1.1	800
25	31	39	35 ~ 43	86	50	0.01	1.2	770
30	38	47	42 ~ 52	104	50	0.01	1.5	680
35	45	56	50 ~ 62	123	50	0.01	1.8	540
40	56	68	61 ~ 75	150	50	0.01	1.8	430
50	65	82	74 ~ 90	145	200	0.1	0.7	250
60	85	100	90 ~ 110	175	200	0.1	2.0	200
75	100	120	108 ~ 132	210	200	0.1	2.5	170
95	125	150	135 ~ 165	260	200	0.1	3.0	140
130	170	200	185 ~ 225	355	200	0.1	4.0	80
140	180	220	198 ~ 242	380	200	0.1	4.5	70
150	200	240	216 ~ 264	415	200	0.1	5.0	70
175	225	270	247 ~ 303	475	200	0.1	6.0	65
230	300	360	324 ~ 396	620	200	0.1	7.5	50
250	320	390	351 ~ 429	675	200	0.1	8.0	50
275	350	430	387 ~ 473	745	200	0.1	9.0	45
300	385	470	423 ~ 517	810	200	0.1	10.0	40

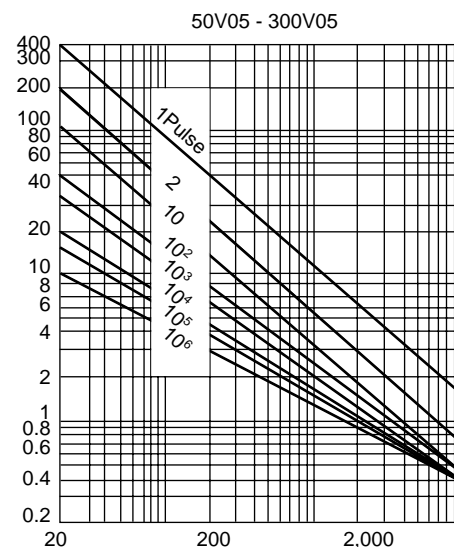

■ 7mm SPECIFICATIONS and PULSE LIFETIME RATINGS; RECTANGULAR WAVE (µsec.)

Maximum Allowable Voltage (V)		Varistor Voltage (V) 0.1mA		Max. Clamping Voltage Vc (V)	Withstd. Surge Current (A)	Rated Wattage (W)	Energy @2ms (J)	Typical Cap. @1KHz (pF)
ACrms	DC	V	Tol. (min.-max.)					
11	14	18	14.4 - 21.6	36	125	0.02	1.2	2200
14	18	22	18.7 - 26.0	43	125	0.02	1.4	2100
17	22	27	23.0 - 31.1	53	125	0.02	1.7	1850
20	26	33	29.5 - 36.5	65	125	0.02	2.2	1580
25	31	39	35 - 43	77	125	0.02	2.4	1510
30	38	47	42 - 52	93	125	0.02	3.0	1460
35	45	56	50 - 62	110	125	0.02	3.5	1410
40	56	68	61 - 75	135	125	0.02	4.3	1350
50	65	82	74 - 90	135	600	0.25	3.5	550
60	85	100	90 - 110	165	600	0.25	4.0	500
75	100	120	108 - 132	200	600	0.25	5.0	450
95	125	150	135 - 165	250	600	0.25	6.0	350
130	170	200	185 - 225	340	600	0.25	10.0	250
140	180	220	198 - 242	360	600	0.25	10.0	250
150	200	240	216 - 264	395	600	0.25	10.0	200
175	225	270	247 - 303	455	600	0.25	12.0	170
210	275	330	297 - 863	550	600	0.25	14.0	125
230	300	360	324 - 396	595	600	0.25	15.0	130
250	320	390	351 - 429	650	600	0.25	17.0	130
275	350	430	387 - 473	710	600	0.25	20.0	110
300	385	470	423 - 517	775	600	0.25	20.0	100

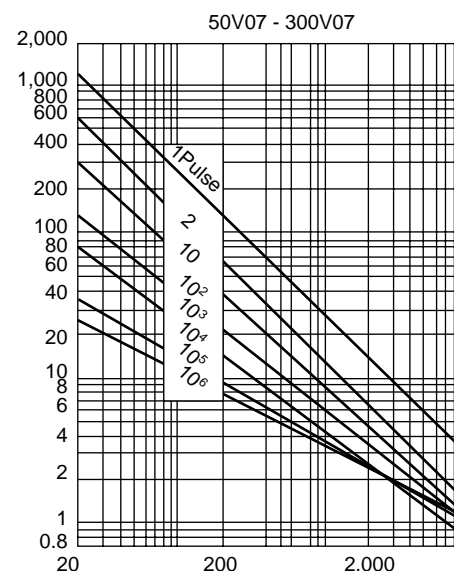

■ 10mm SPECIFICATIONS and PULSE LIFETIME RATINGS;
RECTANGULAR WAVE (µsec.)

Maximum Allowable Voltage (V)		Varistor Voltage (V) 0.1mA		Max. Clamping Voltage Vc (V)	Withstd. Surge Current (A)	Rated Wattage (W)	Energy @2ms (J)	Typical Cap. @1KHz (pF)
ACrms	DC	V	Tol. (min.-max.)					
11	14	18	14.4 - 21.6	36	250	0.05	2.4	4250
14	18	22	18.7 - 26.0	43	250	0.05	2.7	3700
17	22	27	23.0 - 31.1	53	250	0.05	3.5	3600
20	26	33	29.5 - 36.5	65	250	0.05	4.4	3300
25	31	39	35 - 43	77	250	0.05	4.7	3030
30	38	47	42 - 52	93	250	0.05	6.0	2920
35	45	56	50 - 62	110	250	0.05	7.0	2820
40	56	68	61 - 75	135	250	0.05	8.5	2700
50	65	82	74 - 90	135	1,250	0.4	8.0	1,800
60	85	100	90 - 110	165	1,250	0.4	10.0	1,400
75	100	120	108 - 132	200	1,250	0.4	12.0	1,100
95	125	150	135 - 165	250	1,250	0.4	16.0	900
130	170	200	185 - 225	340	1,250	0.4	20.0	500
140	180	220	198 - 242	360	1,250	0.4	23.0	450
150	200	240	216 - 264	395	1,250	0.4	25.0	400
175	225	270	247 - 303	455	1,250	0.4	30.0	350
230	300	360	324 - 396	595	1,250	0.4	35.0	300
250	320	390	351 - 429	650	1,250	0.4	40.0	270
275	350	430	387 - 473	710	1,250	0.4	45.0	250
300	385	470	423 - 517	775	1,250	0.4	45.0	230
350	460	560	504 - 616	920	1,250	0.4	45.0	170
385	505	620	558 - 682	1,025	1,250	0.4	45.0	130
420	560	680	612 - 748	1,120	1,250	0.4	45.0	130
460	615	750	675 - 825	1,240	1,250	0.4	50.0	120
485	640	780	702 - 858	1,290	1,250	0.4	50.0	120
510	670	820	738 - 902	1,355	1,250	0.4	55.0	110
550	745	910	819 - 1001	1,500	1,250	0.4	60.0	100
625	825	1000	900 - 1100	1,650	1,250	0.4	65.0	90
680	895	1100	990 - 1210	1,815	1,250	0.4	70.0	80

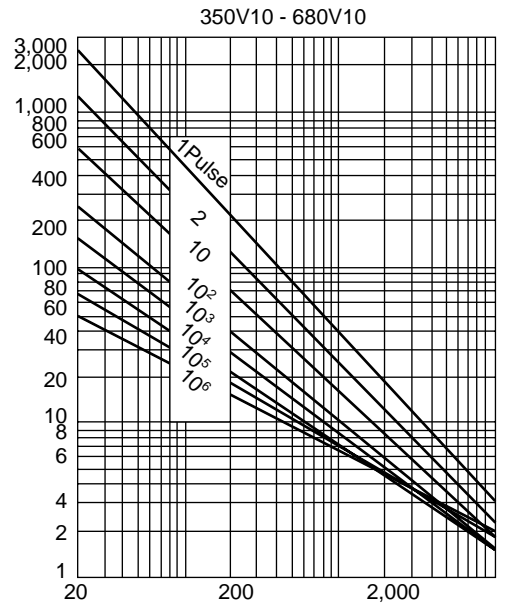
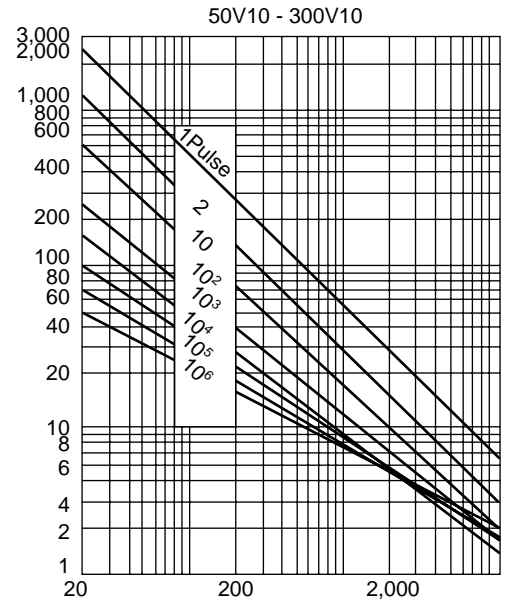

14mm SPECIFICATIONS and PULSE LIFETIME RATINGS; RECTANGULAR WAVE (µsec.)

Maximum Allowable Voltage (V)		Varistor Voltage (V) 0.1mA		Max. Clamping Voltage Vc (V)	Withstd. Surge Current (A)	Rated Wattage (W)	Energy @2ms (J)	Typical Cap. @1KHz (pF)
ACrms	DC	V	Tol. (min.-max.)					
11	14	18	14.4 ~ 21.6	36	1000	0.1	4.7	8300
14	18	22	18.7 ~ 26.0	43	1000	0.1	5.4	7150
17	22	27	23.0 ~ 31.1	53	1000	0.1	6.9	7050
20	26	33	29.5 ~ 36.5	65	1000	0.1	8.8	6530
25	31	39	35 ~ 43	77	1000	0.1	9.4	5900
30	38	47	42 ~ 52	93	1000	0.1	12.0	5840
35	45	56	50 ~ 62	110	1000	0.1	14.0	5640
40	56	68	61 ~ 75	135	1000	0.1	17.0	5400
50	65	82	74 ~ 90	135	4500	0.6	22.0	2000
60	85	100	90 ~ 110	165	4500	0.6	28.0	1700
75	100	120	108 ~ 132	200	4500	0.6	32.0	1400
95	125	150	135 ~ 165	250	4500	0.6	44.0	1050
115	150	180	162 ~ 198	300	4500	0.6	52.0	970
130	170	200	185 ~ 225	340	4500	0.6	57.0	870
140	180	220	198 ~ 242	360	4500	0.6	62.0	800
150	200	240	216 ~ 264	395	4500	0.6	67.0	750
175	225	270	247 ~ 303	455	4500	0.6	79.0	690
195	250	300	270 ~ 330	505	4500	0.6	84.0	600
210	275	330	297 ~ 363	550	4500	0.6	92.0	550
230	300	360	324 ~ 396	595	4500	0.6	104.0	500
250	320	390	351 ~ 429	650	4500	0.6	120.0	470
275	350	430	387 ~ 473	710	4500	0.6	132.0	430
300	385	470	423 ~ 517	775	4500	0.6	140.0	390
320	418	510	459 ~ 561	842	4500	0.6	148.0	340
350	460	560	504 ~ 616	920	4500	0.6	156.0	310
385	505	620	558 ~ 682	1025	4500	0.6	164.0	280
420	560	680	612 ~ 748	1120	4500	0.6	172.0	255
460	615	750	675 ~ 825	1240	4500	0.6	180.0	230
485	640	780	702 ~ 858	1290	4500	0.6	184.0	225
510	670	820	738 ~ 902	1355	4500	0.6	188.0	210
550	745	910	819 ~ 1001	1500	4500	0.6	204.0	190
625	825	1000	900 ~ 1100	1650	4500	0.6	224.0	175
680	895	1100	990 ~ 1210	1815	4500	0.6	248.0	160

50V14 ~ 300V14

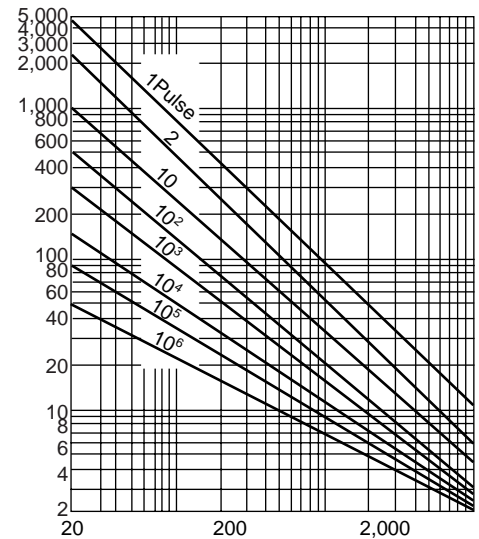

350V14 ~ 680V14

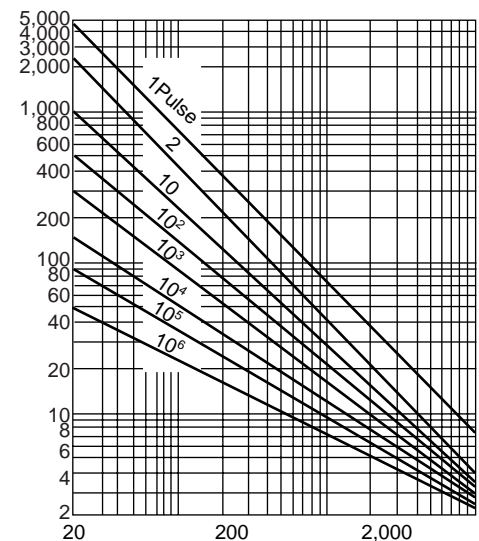

■ 20mm SPECIFICATIONS and PULSE LIFETIME RATINGS;
RECTANGULAR WAVE (µsec.)

Maximum Allowable Voltage (V)		Varistor Voltage (V) 0.1mA		Max. Clamping Voltage Vc (V)	Withstd. Surge Current (A)	Rated Wattage (W)	Energy @2ms (J)	Typical Cap. @1KHz (pF)
ACrms	DC	V	Tol. (min.-max.)					
11	14	18	14 ~ 22	36	2000	0.2	7.0	16900
14	18	22	18 ~ 26	43	2000	0.2	8.0	14400
17	22	27	22 ~ 32	53	2000	0.2	10.0	14100
20	26	33	27 ~ 39	65	2000	0.2	12.0	13400
25	31	39	34 ~ 44	77	2000	0.2	14.0	11950
30	38	47	40 ~ 54	93	2000	0.2	17.0	11700
35	45	56	48 ~ 64	110	2000	0.2	20.0	11300
40	56	68	58 ~ 78	135	2000	0.2	24.0	10800
50	65	82	74 ~ 90	135	6500	1.0	44.0	4000
60	85	100	90 ~ 110	165	6500	1.0	56.0	3400
75	100	120	108 ~ 132	200	6500	1.0	64.0	2800
95	125	150	135 ~ 165	250	6500	1.0	88.0	2530
115	150	180	162 ~ 198	300	6500	1.0	104.0	2110
130	170	200	185 ~ 225	340	6500	1.0	114.0	1900
140	180	220	198 ~ 242	360	6500	1.0	124.0	1740
150	200	240	216 ~ 264	395	6500	1.0	134.0	1590
175	225	270	247 ~ 303	455	6500	1.0	158.0	1415
195	250	300	270 ~ 330	505	6500	1.0	168.0	1280
210	275	330	297 ~ 363	550	6500	1.0	184.0	1160
230	300	360	324 ~ 396	595	6500	1.0	208.0	1065
250	320	390	351 ~ 429	650	6500	1.0	240.0	985
275	350	430	387 ~ 473	710	6500	1.0	264.0	890
300	385	470	423 ~ 517	775	6500	1.0	280.0	870
320	418	510	459 ~ 561	842	6500	1.0	296.0	760
350	460	560	504 ~ 616	920	6500	1.0	312.0	680
385	505	620	558 ~ 682	1025	6500	1.0	328.0	620
420	560	680	612 ~ 748	1120	6500	1.0	344.0	565
460	615	750	675 ~ 825	1240	6500	1.0	360.0	510
485	640	780	702 ~ 858	1290	6500	1.0	368.0	490
510	670	820	738 ~ 902	1355	6500	1.0	376.0	460
550	745	910	819 ~ 1001	1500	6500	1.0	408.0	420
625	825	1000	900 ~ 1100	1650	6500	1.0	448.0	380
680	895	1100	990 ~ 1210	1815	6500	1.0	496.0	350

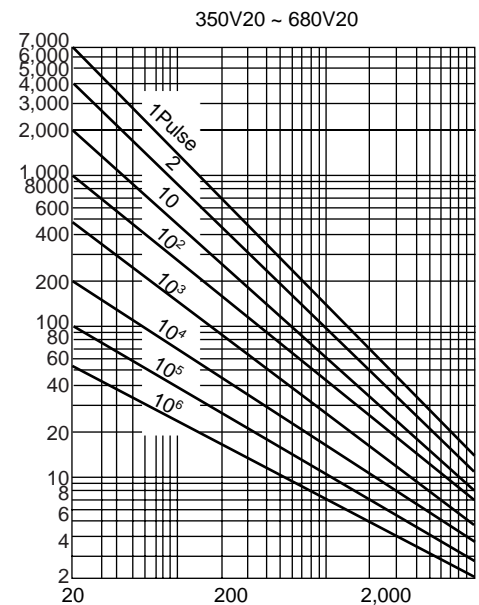
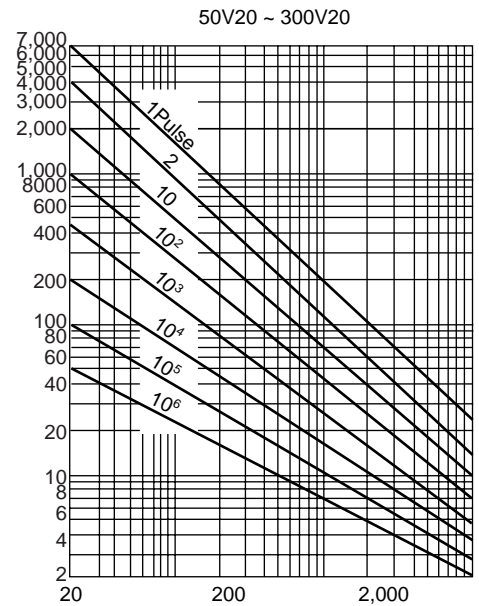

CHARACTERISTICS

FR-085

Range of Values (Ω): 200, 500, 1K, 2K, 5K, 10K, 25K, 50K, 100K, 300K, 500K, 1M
 Tolerance: $\pm 30\%$ (standard)
 Resistance Taper: Linear taper "B" only
 Wattage Rating: 0.1W (standard)
 Rotational Torque: 20 ~ 30gcm (0.427 ~ 4.27in-oz) (standard)
 Rotational Life: 15% resistance change max. after 100 rotational life test
 Contact Force: 20g minimum to force contact of wiper on carbon
 Mechanical Strength: Bakelite base can not be broken down by adding force of 1kg
 Stop-end Torque: 0.5kg-cm minimum (standard)
 Rotational Angle: 220° min.
 Temperature Characteristic: +5% and -30% resistance change after 5 hours at 70°C
 Load Characteristic: 5% resistance change max. after 3 hours rated load
 Humidity Characteristic: 15% resistance change max. after 5 hours in 95% RH @ 40°C
 Load Life in Humidity: 20% resistance change max. after rated load for 350 hours in 90% RH @ 40°C

FR-086

Range of Values (Ω): 200, 500, 1K, 2K, 5K, 10K, 25K, 50K, 100K, 250K, 500K, 1M
 Tolerance: $\pm 25\%$
 Resistance Taper: Linear
 Wattage Rating: 0.1W
 Rotational Torque: 300 ~ 300gcm
 Stop-end Torque: 0.5kg-cm min.
 Rotational Angle: 220°

PART NUMBERING SYSTEM

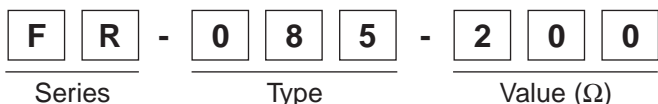

DIMENSIONS (mm)

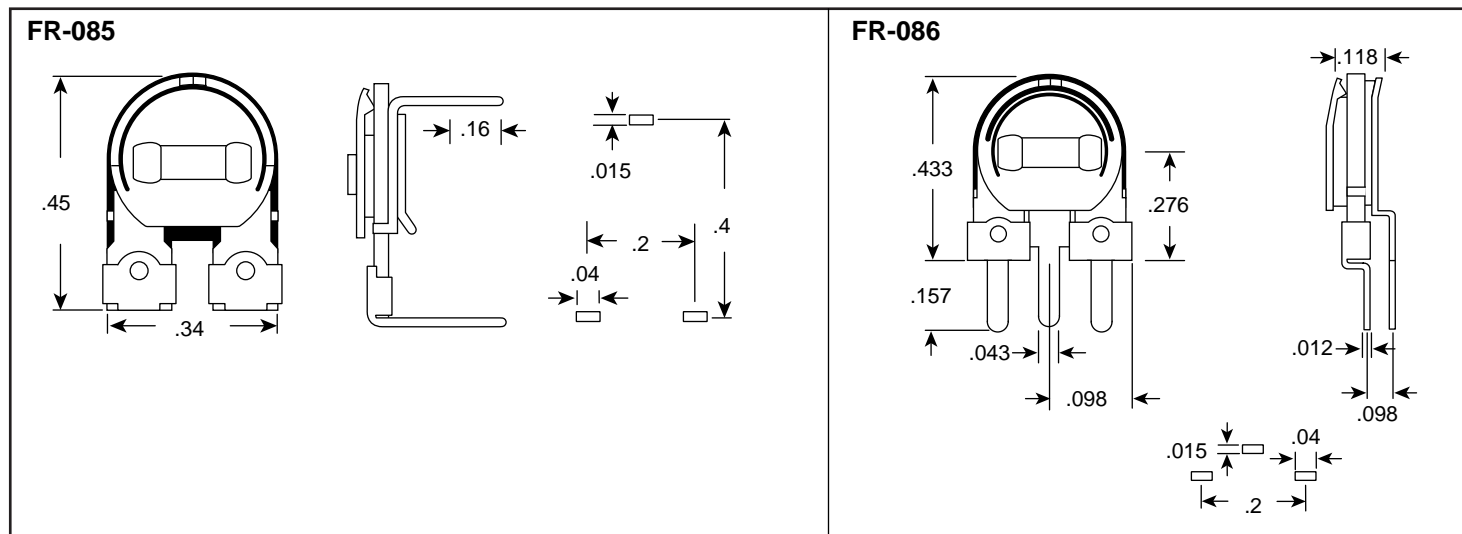

■ CHARACTERISTICS

LU-085

Range of Values (Ω): 1K, 5K, 10K, 50K, 100K, 500K
 Tolerance: $\pm 20\%$
 Resistance Taper: Linear
 Wattage Rating: 0.1W
 Minimum Resistance: 5% max.
 Rotational Torque: 50 ~ 350gcm
 Rotational Life: $\pm 15\%$ max. after 100 rotations
 Stop-end Torque: 1kg-cm min.
 Rotational Angle: $230^\circ \pm 20^\circ$
 Temperature Characteristic: +5% and -20% max. after 250 hours at 70°C

LU-083

Range of Values (Ω): 1K, 5K, 10K, 50K, 100K, 500K
 Wattage Rating: 0.1W
 Rotational Torque: 40 ~ 300gcm
 Rotational Angle: $25^\circ \pm 20^\circ$
 Max. Ambient Temperature: $+50^\circ\text{C}$

■ PART NUMBERING SYSTEM

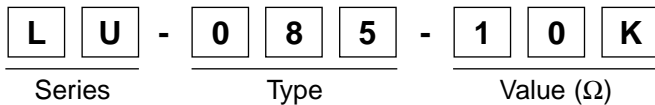



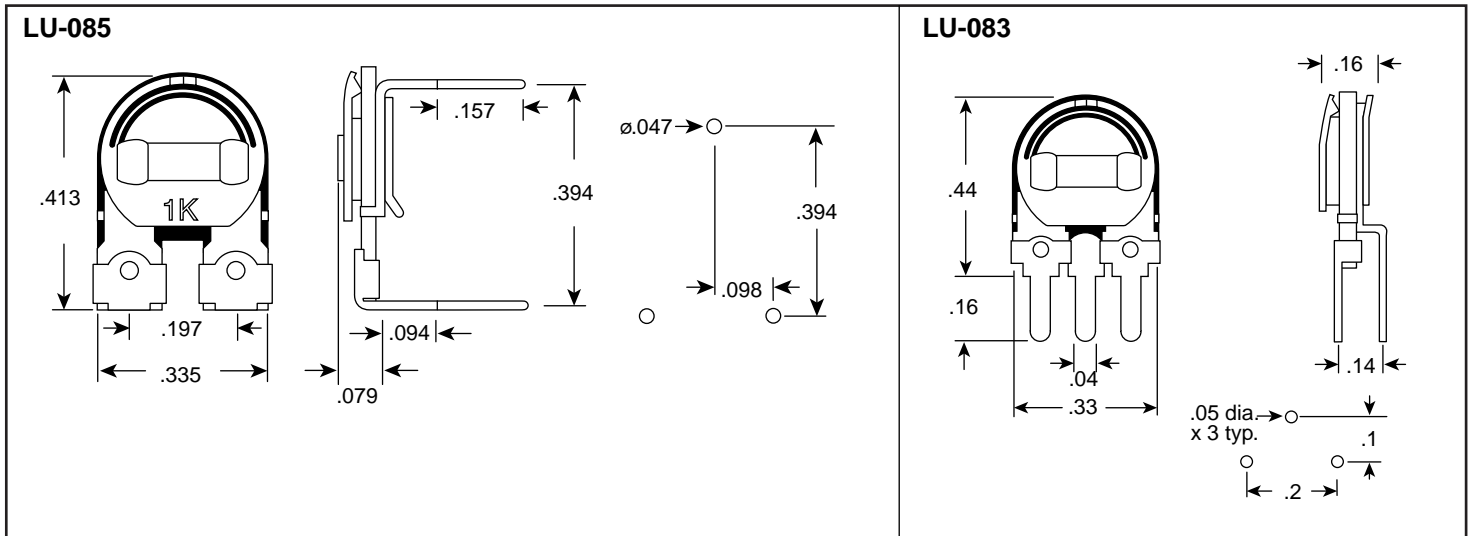













■ DIMENSIONS (mm)































RF - Inductors

HF - Induktivitäten

Series Bauforn	Inductance Range Induktivität (μ H)	Rated Current Nennstrom (mA)	Self Resonant Frequency Resonanzfrequenz (MHz)		Taping Gurtung
0603 SMD	0.0018 - 0.120	300 - 700	1300 - >6000	 Size magnified Abbildung vergrößert	
0805 SMD	0.0022 - 0.68	170 - 600	600 - >6000	 Size magnified Abbildung vergrößert	
1008 SMD	0.01 - 10.0	300 - 1000	60 - 4100	 Size magnified Abbildung vergrößert	
MMICC	1.0 - 100	78 - 500	9.0 - 150		axial
MICC MICC/N 	0.1 - 1000	55 - 1100	1.5 - 600		axial radial
MICCS MICCS/N	1.0 - 220	110 - 725	8.0 - 180		axial radial
SMCC SMCC/N 	0.1 - 10000	25 - 1600	0.35 - 380		axial radial
MSMCC	1.0 - 4700	63 - 1900	1.1 - 140		axial radial
MECC	1.0 - 150	90 - 1800	20 - 180		axial
LACC	1.0 - 56	360 - 2000	29 - 175		axial
HACC	1.0 - 27	850 - 2000	11 - 195		axial
HBCC	1.0 - 100000	120 - 2200	0.02 - 200		axial radial
HCCC	0.7 - 10	1300 - 7000			axial



Suppression Inductors

Entstrördrosseln

Series Bauform	Inductance Range Induktivität (μ H)	Rated Current Nennstrom (A)	
VHBCC	10 - 100000	0.045 - 4.600	
XHBCC	100 - 100000	0.060 - 1.86	
MISC  	1 - 100	0.15 - 4.0	
SMSC  	1 - 160	0.15 - 6.0	
MESC  	3 - 1500	0.08 - 6.0	
LASC  	5 - 470	0.15 - 6.0	
SSSC  	4 - 17	2.0 - 6.0	
MSSC  	3 - 20	3.0 - 9.0	
LSSC  	5 - 25	3.0 - 10.0	
77A  	3.9 - 10000	0.3 - 12.0	
50A  	120 - 8300	0.1 - 2.0	





SMD Power Inductors

SMD Leistungs Induktivitäten

Series Bauform	Inductance Range Induktivität (μH)	Rated Current Nennstrom (A)	
PISL PISM PISN	10 - 1000 1 - 1000 10 - 100	0.1 - 22 0.35 - 6.9 0.2 - 4.9	
PISR	1 - 1000	0.57 - 8.6	

Pluggable Inductors

Induktivitäten, stehend

Series Bauform	Inductance Range Induktivität (μH)	Rated Current Nennstrom (mA)	Cap Version mit Kappe	Tube Version mit Schrumpfschlauch
07P	680 - 8200	50 - 170		
09P 09P/F	10 - 33000	50 - 2400		
11P	10000 - 150000	35 - 110		



Shielded Pluggable Inductors

Induktivitäten, geschirmt

Series Bauform	Inductance Range Induktivität (μH)	Rated Current Nennstrom (mA)	
07M	1.0 - 82	10 - 90	

Wide Band Chokes

Breitbanddrosseln

Series Bauform	Impedance Impedanz (Ω)	Frequency Arbeitsfrequenz (MHz)	
06H	1000	500	
Beads	180	500	

Series Bauform	Delivery Form Lieferform	Loose / Plastic Bag Lose / Plastiktüte	Loose / Box Lose / Schachtel	Taped / Reel Gegurtet / Rolle	Taped / Ammopack Gegurtet / Ammopack
0603 SMD				3000 [-01]	
0805 SMD				3000 [-01]	
1008 SMD				2000 [-01]	
MMICC	axial preformed	2000 [-00] 2000 [-20]	12000 [-00]	6000 [-01]	3000 [-02]
MICC MICC/N	axial preformed radial	500 [-00] 1000 [-20] 500 [-50]	4000 [-00] 8000 [-20] 4000 [-50]	4000 [-01] 2000 [-31]	1500 [-02] 3500 [-32]
MICCS	axial preformed radial	500 [-00] 1000 [-20] 500 [-50]	4000 [-00] 8000 [-20] 4000 [-50]	4000 [-01] 2000 [-31]	1500 [-02] 3500 [-32]
SMCC SMCC/N	axial preformed radial	500 [-00] 1000 [-20] 500 [-50]	3000 [-00] 6000 [-20] 3000 [-50]	3500 [-01] 1500 [-31]	1200 [-02] 2500 [-32]
MSMCC	axial preformed radial	500 [-00] 500 [-50]	1000 [-00] 1500 [-20] 3000 [-50]	3000 [-01] 1500 [-31]	1000 [-02] 2500 [-32]
MECC	axial preformed	500 [-00]	2000 [-00] 1500 [-20]	3000 [-01]	1200 [-02]
LACC	axial preformed	500 [-00]	2000 [-00] 1500 [-20]	3000 [-01]	1200 [-02]
HACC	axial	500 [-00]	3000 [-00]	3500 [-01]	1200 [-02]
HBCC	axial radial	500 [-00]	1000 [-00]	1200 [-01] 1000 [-31]	600 [-02] 1200 [-32]
HCCC	axial	500 [-00]	1000 [-00]	2500 [-01]	1000 [-02]
VHBCC	axial			1200 [-01]	
XHBCC	axial			800 [-01]	
MISC	axial		1000 [-00]	1500 [-01]	
SMSC	axial		1000 [-00]	1500 [-01]	
MESC	axial		500 [-00]	1000 [-01]	
LASC	axial		400 [-00]	1000 [-01]	
SSSC	axial		500 [-00]		
MSSC	axial		350 [-00]		
LSSC	axial		200 [-00]		
77A	axial		300 [-00]	500 [-01]	
50A	axial		150 [-00]		
07P	radial		500 [-50]	700 [-51]	
09P	radial		500 [-50]	500 [-51]	
11P	radial		250 [-50]		
PISL				1000 [-04]	
PISM				1000 [-04]	
PISN				225 [-04]	
PISR				250 [-04]	
07M	radial		250 [-50]		
06H	axial		300 [-00]		
Beads / 4				3000 [-01]	1000 [-02]
Beads / 8				3000 [-01]	1000 [-02]
Beads / 10				3000 [-01]	1000 [-02]

[] = Delivery Form Code / Lieferform Code



Technical Data

1. Rated Current : See Graph
2. DC - Resistance : Measured at 25°C
3. Solderability : Max. 260°C, 10 seconds
4. Wire Termination : Spot Welded
5. Operation Temperature : IEC Climatic Category
55/125/56 (Ceramic)
55/85/56 (Ferrite)
DIN Climatic Category FKF
-55°C to 125°C Humidity
Category F (Ceramic)
FPF -55°C to 85°C Humidity
Category F (Ferrite)
6. Resistance to Solvent : According to MIL-STD-202E
7. Packing : 8mm Blister Tape (EIA-481)
on reel (ø180mm)
8. L - Tolerance : See Table
9. PAD - Metallization : Ceramic: tungsten, nickel with
gold-flash
Ferrite: silver, nickel with
gold-flash
10. Surface Finishing : Epoxy moulded flat top for
perfect component centering
and vacuum pickup
11. Solder Pads : Recommended layout see
next page
12. Soldering Methods : Wave Soldering
Reflow Soldering
Vapor Phase Soldering
13. Marking : See Below

Technische Daten

1. Nennstrom : siehe Grafik
2. Ohmscher Widerstand : gemessen bei 25°C
3. Lötbarkeit : max. 260°C, 10 Sekunden
4. Anschlüsse : geschweißt
5. Betriebstemperatur : IEC Klimakategorie
55/125/56 (Keramik)
55/85/56 (Ferrit)
DIN Anwendungsklasse FKF
-55°C bis 125°C Feuchteklasse
F (Keramik) PPF
-55°C bis 85°C (Ferrit)
6. Lösungsmittelbeständigkeit : Entsprechend MIL-STD-202E
7. Verpackung : Blistergurt 8mm (EIA-481)
auf Rolle (ø180mm)
8. L - Toleranzen : Siehe Tabelle
9. Material der Lötflächen : Keramik: Wolfram, Nickel mit
Hauchvergoldung
Ferrit: Silber, Nickel mit
Hauchvergoldung
10. Oberfläche : Epoxy-vergossene glatte
Oberseite ermöglicht genaues
Zentrieren und Aufnehmen
mittels Vakuumpinzette
11. Leiterplatten Layout : siehe nachstehende
Empfehlung
12. Zulässige Lötverfahren : Wellenlöten, Reflowlöten,
Dampfphasenlöten
13. Markierung : siehe unten

Taping Specification / Gurtmaße

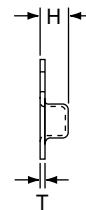
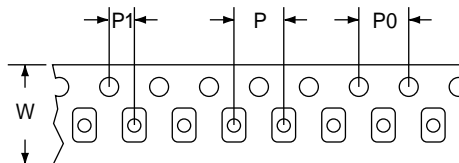
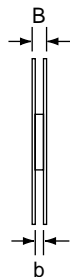
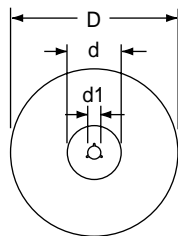

Series	D	d	d1	B	b	W	P	P0	P1	H	T
0603	180	60	13	12.7	8.4	8	4	4	2	1.0	0.2
0805	180	60	13	12.7	8.4	8	4	4	2	1.6	0.2
1008	180	60	13	12.7	8.4	8	4	4	2	2.3	0.3

Marking / Markierung	0805 / 1008	0603 Colour Code / Farbcode
Example: 0805 AD - 033M-01 Beispiel	L = 33nH	See Page 106 siehe Seite 106

Series
Bauform

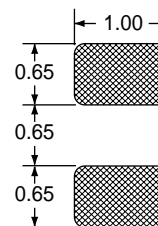
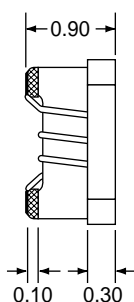
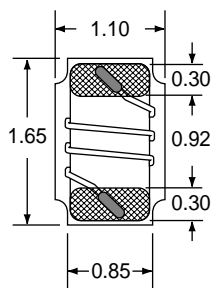

Recommended layout for solder pads
Empfohlenes Leiterplatten Layout

Ordering Code Bestellbezeichnung	Inductance Induktivität L (nH)	f_L (MHz)	Tol. %	Q min.	f_a (MHz)	SRF min. (GHz)	DC-Res. max. (Ω)	Rated DC Current Nennstrom (mA)	Material
0603AD-1N8K-01	1.8	250	± 10.5	16	250	6.00	0.045	700	Ceramic (Keramik)
0603AD-3N9K-01	3.9			22		6.00	0.080	700	
0603AD-6N8K-01	6.8			$\pm 10.5.2$		27	5.80	0.110	
0603AD-010J-01	10		± 5.2	31		4.80	0.130	700	
0603AD-012J-01	12			35		4.00	0.130	700	
0603AD-015J-01	15			35		4.00	0.170	700	
0603AD-018J-01	18			35		3.10	0.170	700	
0603AD-022J-01	22			38		3.00	0.190	700	
0603AD-027J-01	27			38		2.80	0.220	600	
0603AD-033J-01	33			40		2.30	0.220	600	
0603AD-039J-01	39	200	40	2.20	0.250	600			
0603AD-047J-01	47		40	2.00	0.280	600			
0603AD-056J-01	56		38	1.90	0.310	600			
0603AD-068J-01	68		38	1.70	0.340	600			
0603AD-072J-01	72	150	37	1.70	0.490	400			
0603AD-082J-01	82		34	1.70	0.540	400			
0603AD-R10J-01	100		34	1.40	0.580	400			
0603AD-R11J-01	110		34	1.35	0.610	300			
0603AD-R12J-01	120		32	1.30	0.650	300			

Marking / Markierung

as the space on these inductors is very limited, the marking is done by coloured epoxy
Wegen des sehr geringen Platzes werden die Bauteile durch eingefärbtes Epoxy gekennzeichnet

L (nH)	Colour of Epoxy Farbe des Epoxy	L (nH)	Colour of Epoxy Farbe des Epoxy
1.8	Black	39	Black
3.9	Brown	47	Brown
6.8	Red	56	Red
10	Orange	68	Orange
12	Yellow	72	Yellow
15	Green	82	Green
18	Blue	100	Blue
22	Violet	110	Violet
27	Grey	120	Grey
33	White		

Other Product Lines Available Through Xicon

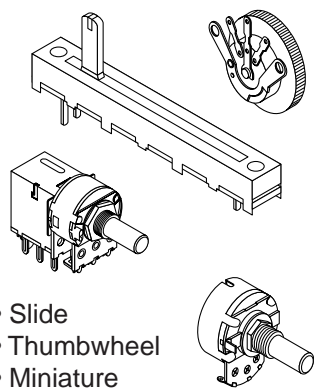
- Slide
- Thumbwheel
- Miniature
- 9mm-25mm Potentiometers



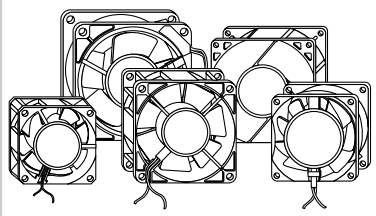

- DC Brushes
- AC Tubeaxial
- Cooling Fans and Accessories





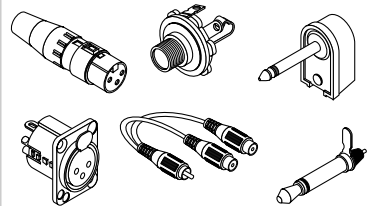

- Microphone Elements
- Earphones
- Speakers
- Piezo Buzzers
- Magnetic Transducers
- Telephone Ringer

- Professional Audio Cables
- Cable Assemblies
- Auto Power Connectors
- DC Power Jacks and Plugs
- Deltron Audio Connectors
- Gotham Cable

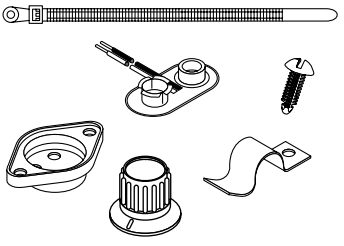
- Transistor Covers & Mounts
- Battery Snaps and Holders
- Hardware
- Wire/Cable Accessories
- PCB Products
- Knobs

- Inductors
- Ferrite Beads
- Chokes
- Coils

- Wall adapters
- Transformers
- SMD Inductors
- Coils, Chokes, Ferrite Beads
- Antennas

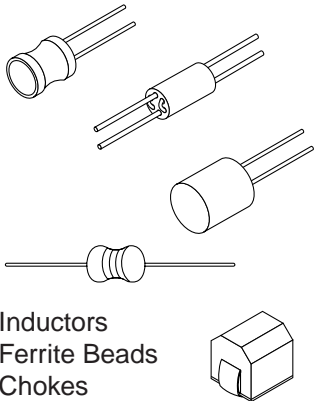

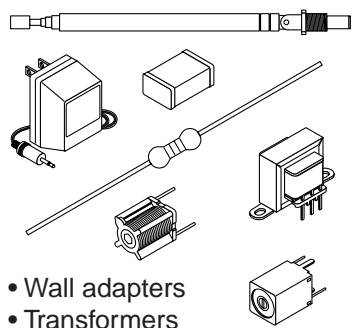
Toggle, Snap Action, Rocker, Push Button, Slide, Keypad, Binary, Rotary, Thumbwheel, Hexadecimal, Dip, Security, Mercury and Non-Mercury

Displays, Surface Mount, Standard, Super Bright, Blinking, Dual Color, Pin Point, Chip, Special Shapes

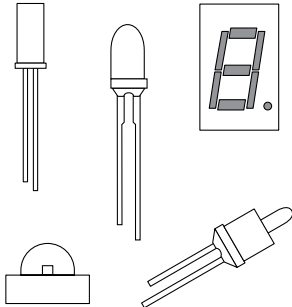



Xicon Passive Components
P.O. Box 170537 Arlington, TX 76003
Tel: (800) 628-0544, Local: (817) 561-2202
Fax: (817) 561-2395
www.xicon-passive.com

Specifications and dimensions in this catalog
are subject to change without notice.
Please Confirm When Ordering.
Not all items shown in the catalog are stock items.
Printed in U.S.A. Copyright 1999