

ASDL-6270

High Performance Silicon NPN Phototransistor in Dark T-1 $\frac{3}{4}$ Package



Data Sheet

Description

ASDL-6270 is a silicon phototransistor in a standard T-1 $\frac{3}{4}$ molded package that optically filters the visible light, hence it is not sensitive to ambient light interference. It has high sensitivity, high speed and low dark current. The collector is denoted by a flat on the packaging diagram and the shorter of the two leads.

Features

- T-1 $\frac{3}{4}$ package
- Special Dark Lens that Filter Visible Light
- High Sensitivity
- Narrow Viewing Angle
- Low Cost
- Lead-Free & ROHS compliant
- Available in Tape & Reel

Applications

- Suitable for detectors of Infrared Applications
- Photo Interrupter
- Industrial Electronics & Equipment
- Consumer Electronics

Ordering Information

Part Number	Lead Form	Color	Packaging	Shipping Option
ASDL-6270-D22	Straight	Dark	Tape & Reel	4000pcs
ASDL-6270-D31			Bulk	8000pcs / Carton

Package Dimensions

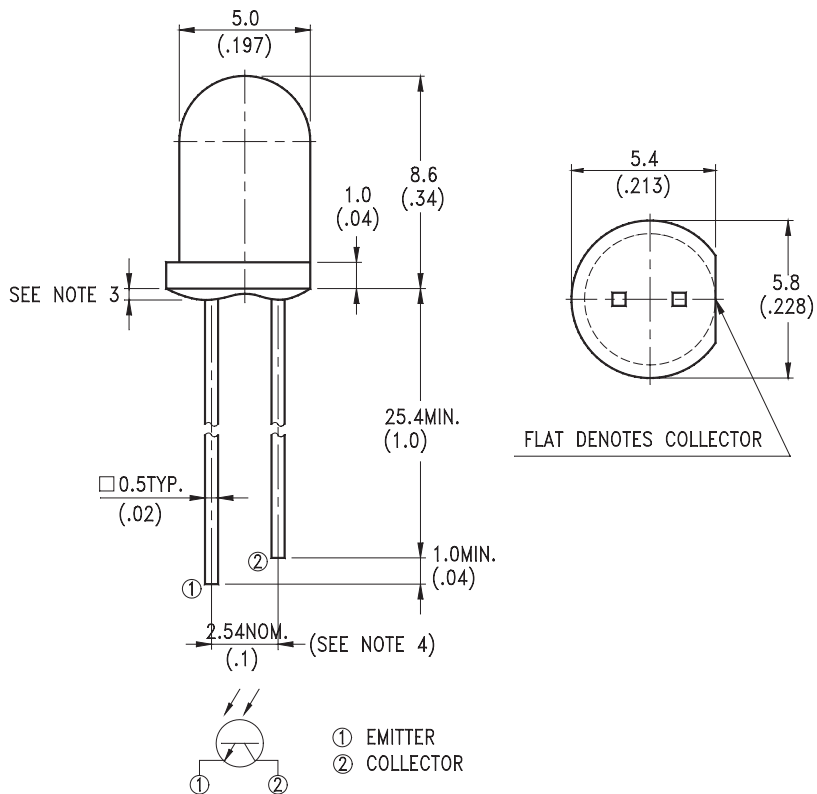

Notes:

1. All dimensions are in millimeters (inches)
2. Tolerance is + 0.25mm (.010") unless otherwise noted
3. Protruded resin under flange is 1.5mm (.059") max
4. Lead spacing is measured where leads emerge from package
5. Specifications are subject to change without notice.

Absolute Maximum Ratings at TA=25°C

Parameter	Symbol	Min.	Max	Unit
Power Dissipation	P _{DISS}		100	mW
Collector Emitter Voltage	V _{CEO}		30	V
Emitter Collector Voltage	V _{ECO}		5	V
Operating Temperature	T _O	-40	85	°C
Storage Temperature	T _S	-55	100	°C
Junction temperature	T _J		110	°C
Lead Soldering Temperature [.6mm (0.063") From Body]		260°C for 5 seconds		

Electrical Characteristics at 25°C

Parameter	Symbol	Min.	Typ.	Max.	Unit	Condition
Collector-Emitter Breakdown Voltage	V _{(BR)CEO}	30			V	I _C = 1mA E _e = 0mW/cm ²
Emitter-Collector Breakdown Voltage	V _{(BR)ECO}	5			V	I _e = 100μA E _e = 0mW/cm ²
Collector Emitter Saturation Voltage	V _{CE(SAT)}		0.1	0.4	V	I _C = 100μA E _e = 1mW/cm ²
Collector Dark Current	I _{CEO}			100	nA	V _{CE} = 10V E _e = 0mW/cm ²
Thermal Resistance, Junction to Pin	R _{θJP}	-	350		°C/W	

Optical Characteristics at 25°C

Parameter	Symbol	Min.	Typ.	Max.	Unit	Condition
Viewing Angle	2θ _{1/2}		20		Deg	
Wavelength of Peak sensitivity	λ _{PK}		900		nm	
Spectral BandWidth	Δλ	700	900	1100	nm	
Rise Time	t _r		10		μs	V _{CC} = 5V I _C = 1mA R _L = 1KΩ
Fall Time	t _f		15		μs	V _{CC} = 5V I _C = 1mA R _L = 1KΩ
On State Collector Current	I _{C(ON)}	2.4		7	mA	V _{CE} = 5V E _e = 1mW/cm ² λ = 940nm

Typical Electrical/Optical Characteristics Curves ($T_A=25^\circ\text{C}$ unless otherwise indicated)

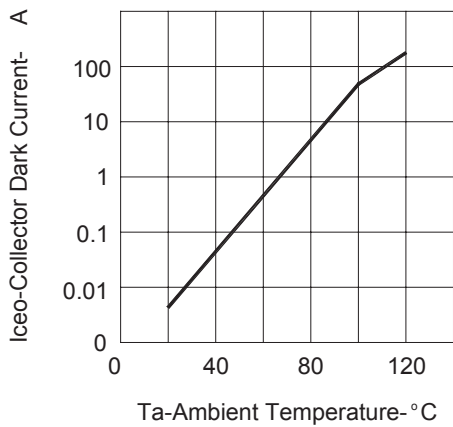

Figure 1. COLLECTOR DARK CURRENT VS AMBIENT TEMPERATURE

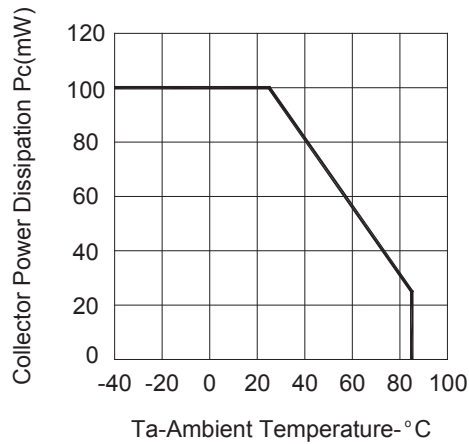

Figure 2. COLLECTOR POWER DISSIPATION VS AMBIENT TEMPERATURE

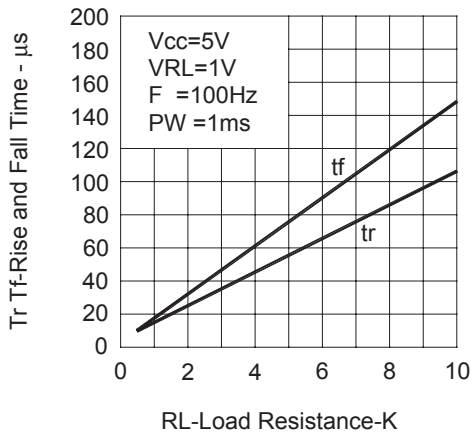

Figure 3. RISE AND FALL TIME VS LOAD RESISTANCE

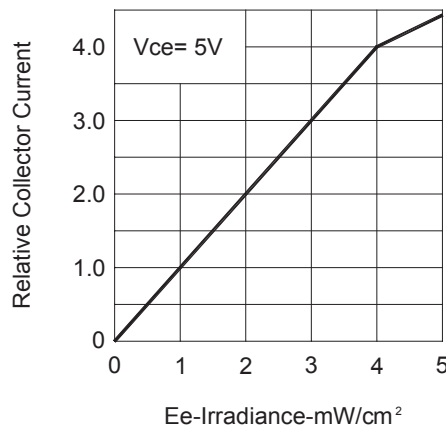

Figure 4. RELATIVE COLLECTOR CURRENT VS IRRADIANCE

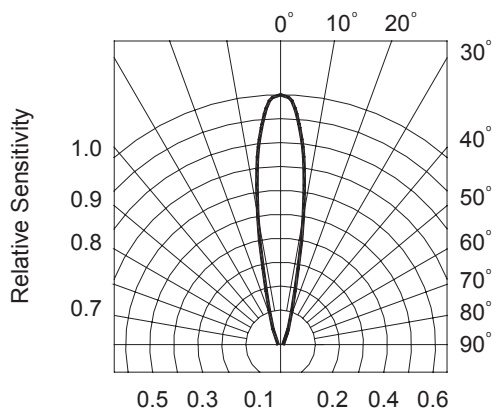

Figure 5. SENSITIVITY DIAGRAM

For product information and a complete list of distributors, please go to our web site: www.avagotech.com

Avago, Avago Technologies, and the A logo are trademarks of Avago Technologies, Limited in the United States and other countries. Data subject to change. Copyright © 2007 Avago Technologies Limited. All rights reserved. AV02-0012EN - January 22, 2007

