

Push Switch 1.2mm-travel Vertical Type

SPEA Series

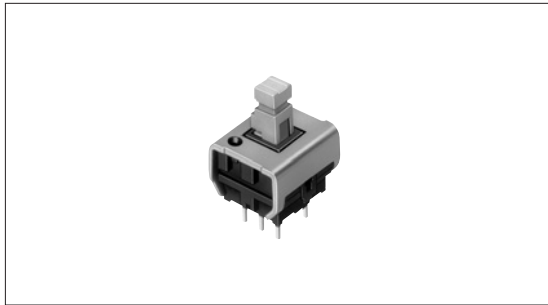

Short travel 1.2mm, vertical type, suitable for multiple circuits.



Features

- 1.2mm-travel.

Applications

- For switching in printers, audio equipment, telephones, measuring devices and various electronic devices

Typical Specifications

Items		Specifications
Rating (max.) / (min.) (Resistive load)		0.1A 30V DC / 50 μ A 3V DC
Contact resistance (Initial / After operating life)		30m Ω max. / 50m Ω max.
Operating force	2-poles	2.5 \pm 1N
	4-poles	3 \pm 1N
Operating life	Without load	10,000cycles
	With load	10,000cycles (0.1A 30V DC)

Product Line

Changeover timing	Travel (mm)	Total travel (mm)	Rating	Mounting method	Poles	Operation	Terminal Configuration	Minimum packing unit (pcs.)	Product No.	Drawing No.
Non shorting	1.2	1.7	—	PC board	2	Latching	Straight	100	SPEA121800	1
							Snap-in		SPEA122100	
					Momentary	Straight	SPEA122200			
					4	Latching	Snap-in		SPEA123000	2

Note

Products other than those listed in the above chart are also available. Please contact us for details.

Detector

Push

Slide

Rotary

Encoders

Power

Dual-in-line
Package Type

Multi Control
Devices

TACT Switch™

Custom-
Products

Horizontal
Type

Vertical
Type

Refer to P.105 for product specifications.

Dimensions

Unit:mm

No.	Style	PC board mounting hole dimensions (Viewed from the direction A)	
1	<p>2-poles</p>	<p>Straight terminal</p>	<p>Snap-in terminal</p>
		<p>Thickness of PC board $t=1.6\text{mm}$</p>	
2	<p>4-poles</p>	<p>Snap-in terminal</p>	
		<p>Thickness of PC board $t=1.6\text{mm}$</p>	

Actuator configuration at front edge Unit:mm

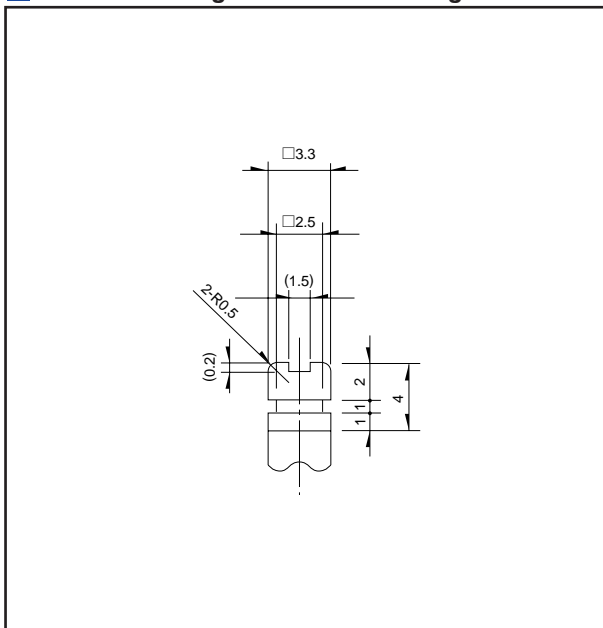

Circuit Diagram (Viewed from the Direction A)

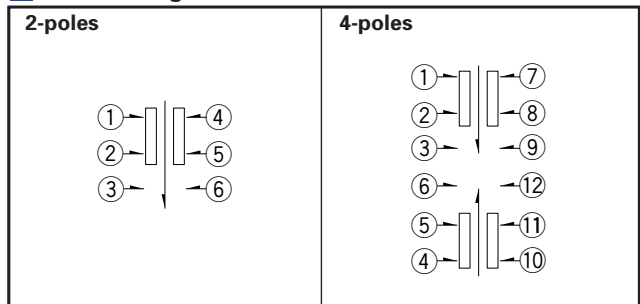

Terminal Configuration

Unit:mm

