

# Bluetooth low energy - Module PAN1720

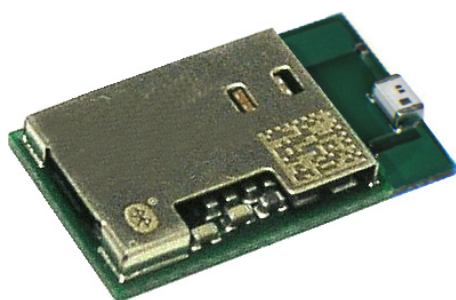

(Module without shielding)

## OUTLINES

This Bluetooth low energy single-mode module has been specially developed for applications which communicate with a dual or single mode Bluetooth low energy devices like mobile phones, PDAs, Laptops etc. So it is very easy to expand you personal area network with this module and using existing gateways. The included Bluetooth low energy stack is currently supporting the Proximity and Battery profile. The user specific application can be written on top of the Bluetooth Stack. The communication between stack and application is handled via vendor specific HCI-Commands. The PAN1720-Module is manufactured in a very small 15.6 x 8.7 x 1.9 mm<sup>3</sup> SMD package with shielded case and will be qualified to the Bluetooth 4.0 standard.

## FEATURES

### General

- Complete Bluetooth low energy solution (Bluetooth 4.0)
- Supported Profiles: Proximity and Battery profiles
- Low power 8051  $\mu$ C included
- Up to 256k Flash and 8k RAM
- Data rates up to 1 Mbps
- IR Generation Circuitry
- AES Security Coprocessor
- Temperature Range from -40°C to +85°C
- Supply Voltage Range from 2.0V to 3.6V, typ. 3.0V
- Dimension only 15.6 x 8.7 x 1.9 mm<sup>3</sup>
- Dimension and Footprint compatible to PAN1320/21

### Interfaces

- Two powerful USARTs with support for several serial protocols
- Full speed USB 2.0 interface
- 19 general-purpose I/O pins (17x 4mA, 2x20 mA)
- 12-Bit ADC with eight channels and configurable resolution

MODULES  
Panasonic Electronic Devices Europe GmbH  
WIRELESS

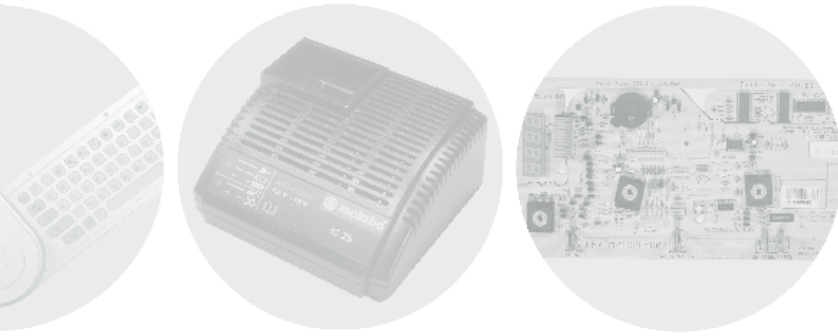

## APPLICATIONS

- 2.4 GHz Bluetooth low energy systems
- Proprietary 2.4 GHz systems
- Human Interface Devices
- Sports and leisure equipment
- Mobile phone accessories
- Remote control for computers, MP3 players
- Consumer Electronics
- USB dongles
- Health Care and Medical

## BLOCK DIAGRAM

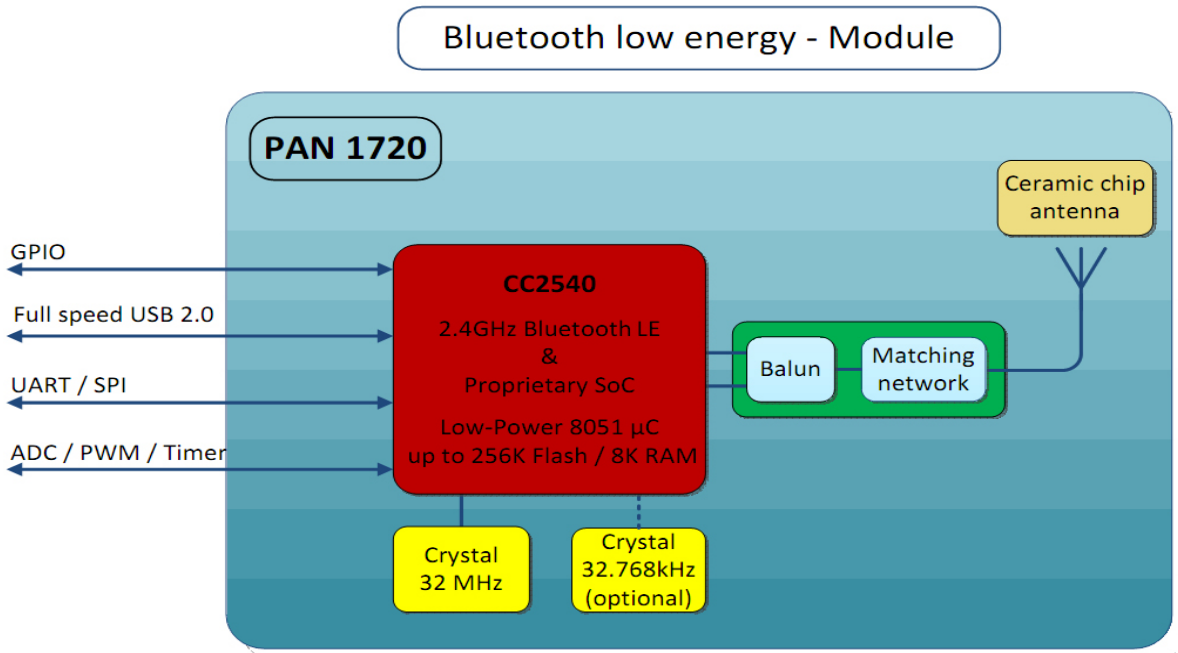

## TECHNICAL CHARACTERISTICS

Parameter	Value	Condition / Note
Receiver Sensitivity (1% PER)	-94 dBm	@ 500 kbps / MSK (high-gain mode)
Output Power	+3 dBm typ.	Maximum setting
Power Supply	2,0 - 3,6 V	Single operation voltage
Sleep Mode	0.5 $\mu$ A	Power mode 3 (lowest)
Transmit Mode	28mA	@ 0dBm (peak current)
Receive Mode	18mA	Standard mode
Operating Temperature Range	-40°C to +85°C	Industrial Range