

SHARP

OPTO-ANALOG DEVICES DIVISION
ELECTRONIC COMPONENTS GROUP
SHARP CORPORATION

SPECIFICATION

SPEC. No. ED-07G047
ISSUE November 15, 2007
ORIGINAL

DEVICE SPECIFICATION FOR

OPIC LIGHT DETECTOR

MODEL No.

GA1A1S203WP

Specified for

Enclosed please find copies of the Specifications which consists of 16 pages including cover.
After confirmation of the contents, please be sure to send back copy of the Specifications
with approving signature on each.

CUSTOMER'S APPROVAL

DATE

BY

PRESENTED

DATE

BY

Y. Oda,
Department General Manager of
Engineering Dept., III
Opto-Analog Devices Div.
ELECOM Group
SHARP CORPORATION



Product name : OPIC LIGHT DETECTOR

Model No. : GA1A1S203WP

1. These specification sheets include materials protected under copyright of Sharp Corporation ("Sharp"). Please do not reproduce or cause anyone to reproduce them without Sharp's consent.
2. When using this product, please observe the absolute maximum ratings and the instructions for use outlined in these specification sheets, as well as the precautions mentioned below. Sharp assumes no responsibility for any damage resulting from use of the product which does not comply with the absolute maximum ratings and the instructions included in these specification sheets, and the precautions mentioned below.

(Precautions)

- (1) This product is designed for use in the following application areas ;

{	· OA equipment · Audio visual equipment · Home appliances	}
	· Telecommunication equipment (Terminal) · Measuring equipment	
	· Tooling machines · Computers	

If the use of the product in the above application areas is for equipment listed in paragraphs (2) or (3), please be sure to observe the precautions given in those respective paragraphs.

- (2) Appropriate measures, such as fail-safe design and redundant design considering the safety design of the overall system and equipment, should be taken to ensure reliability and safety when this product is used for equipment which demands high reliability and safety in function and precision, such as ;

{	· Transportation control and safety equipment (aircraft, train, automobile etc.)	}
	· Traffic signals · Gas leakage sensor breakers · Rescue and security equipment	
	· Other safety equipment	

- (3) Please do not use this product for equipment which require extremely high reliability and safety in function and precision, such as ;

{	· Space equipment · Telecommunication equipment (for trunk lines)	}
	· Nuclear power control equipment · Medical equipment	

- (4) Please contact and consult with a Sharp sales representative if there are any questions regarding interpretation of the above three paragraphs.

3. Please contact and consult with a Sharp sales representative for any questions about this product.

REF ID: A61111

1. Application

This specification applies to the outline and characteristics of Silicon OPIC light detecting device Model No. GA1A1S203WP.

2. Outline

Refer to the attached drawing No. CY14104L02.

3. Ratings and characteristics

Refer to the attached sheet, page 5.

4. Reliability

Refer to the attached sheet, page 6.

5. Outgoing inspection

Refer to the attached sheet, page 7.

6. Supplement

(6-1) Circuit block diagram

Refer to the attached sheet, page 8.

(6-2) Packing

Refer to the attached sheet, attachment -2-1 to 2-4.

(6-3) This product is not designed against electromagnetic and ionized-particle irradiation.

(6-4) This product shall not contain the following materials.

Also, the following materials shall not be used in the production process for this product.

Materials for ODS : CFC_s, Halon, Carbon tetrachloride
1,1,1-Trichloroethane (Methyl chloroform)

(6-5) Compliance with each regulation

6.5.1 The RoHS directive(2002/95/EC)

This product complies with the RoHS directive(2002/95/EC) .

Object substances: mercury, lead, cadmium, hexavalent chromium, Polybrominated biphenyls (PBB) and Polybrominated diphenyl ethers (PBDE)

6.5.2 Content of six substances specified in Management Methods for Control of Pollution Caused by Electronic Information

Products Regulation (Chinese : 电子信息产品污染控制管理办法).

Category	Toxic and hazardous substances					
	Lead (Pb)	Mercury (Hg)	Cadmium (Cd)	Hexavalent chromium (Cr ⁶⁺)	Polybrominated biphenyls (PBB)	Polybrominated diphenyl ethers (PBDE)
OPIC LIGHT DETECTOR	✓	✓	✓	✓	✓	✓

✓ : indicates that the content of the toxic and hazardous substance in all the homogeneous materials of the part is below the concentration limit requirement as described in SJ/T 11363-2006 standard .

(6-6) This product does not contain specific brominated flame retardants such as the PBB and PBDE .

(6-7) Product mass (Piece) : Approximately 3.5mg

REFERENCE

7. Notes

(7-1) By-pass capacitors

In order to stabilize power supply line, connect some by-pass capacitors of 0.01 μ F or more between Vcc and GND within 5mm from lead pins.

(7-2) Cleaning conditions :

Solvent cleaning : Solvent temperature : 45°C or less , Immersion time : 3 min or less

Ultrasonic cleaning : The effect to device by ultrasonic cleaning differs by cleaning bath size, ultrasonic power output, cleaning time, PCB size or device mounting condition etc.

Please test it in actual using condition and confirm that doesn't occur any defect before starting the ultrasonic cleaning.

The cleaning shall be carried out with solvent below.

Solvent : Ethyl alcohol, Methyl alcohol, Isopropyl alcohol

(7-3) Soldering

(7-3-1) Solder reflow

Please do two times or less soldering at the temperature and the time within the temperature profile in attached sheet-1.

(7-3-2) Soldering by hand

To solder onto terminals, please solder at 320°C for 3 seconds or less using soldering iron 50W or less.

Please be careful not to give the mechanical force to the package when soldering because it may cause the deformation or defect due to the plated connection.

(7-3-3) Case of other soldering

Other soldering methods such as dip soldering and VPS should not be used.

Please use (7-3-1) or (7-3-2).

SHARP

REFERENCE

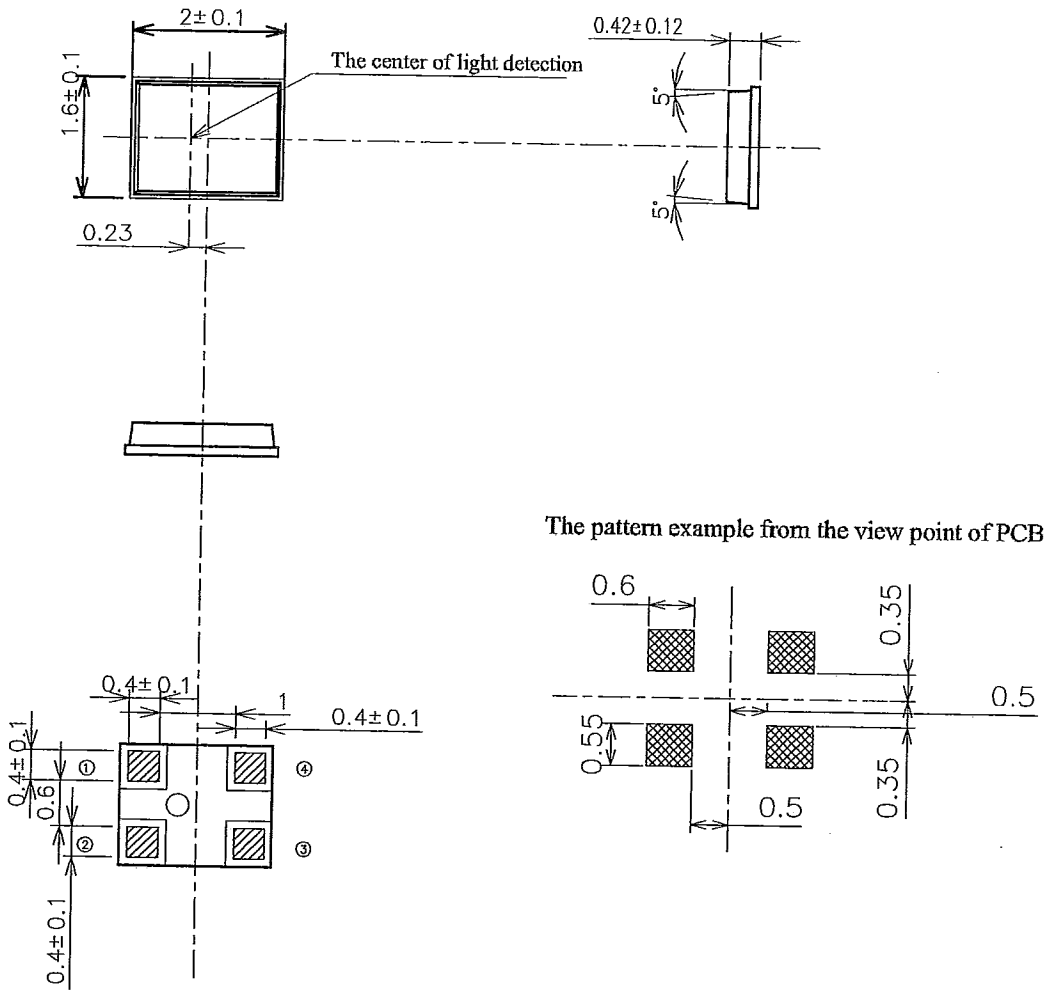

- 1) Unspecified tolerance shall be ± 0.2 mm.
- 2) area : Au plating

Pin arrangement

①	GND
②	GND
③	Io
④	Vcc

Scale	Material	Finish	Name	GA1A1S203WP
10 / 1	Package : Epoxy resin	Pin : Au plating	Outline Dimensions	
Unit			Drawing No.	C Y 1 4 1 0 4 L 0 2
1 = 1 / 1 mm				

REFERENCE

3. Ratings and characteristics

3.1 Absolute maximum ratings

Ta=25°C

Parameter	Symbol	Rating	Unit
Supply voltage	V _{cc}	-0.3 to +7.0	V
Output current	I _o	1	mA
Operating temperature	T _{opr}	-40 to +85	°C
Storage temperature	T _{stg}	-40 to +85	°C
Soldering temperature*	T _{sol}	250	°C

* Within 10s and two times (MAX) according to the attached reflow profile

3.2 Recommended operating conditions

(Condition: Ta = 0 to 70°C)

Parameter	Symbol	MIN.	MAX.	Unit
Supply voltage	V _{CC}	2.3	3.2	V
Dynamic range	D	3	55000	lx

3.3 Electro-optical characteristics

Ta=25°C, V_{cc}=2.9V

Parameter	Symbol	Condition	MIN.	TYP.	MAX.	Unit
Supply current *1,*2	I _{cc}	E _v =1000lx	40	70	150	μA
Output current 1 *1,*2	I _{o1}	E _v =100lx	16	20	24	μA
Output current 2 *1,*2	I _{o2}	E _v =1000lx	27	30	33	μA
Output current 3	I _{o3}	E _v =0lx	-	-	1	μA
Temperature Coefficient	α1	Ta=-30°C to +70°C, E _v =1000lx	-	-	0.25	%/°C
	α2	Ta=0°C to +50°C, E _v =1000lx	-	-	0.2	%/°C
Peak sensitivity	λ _p	-	-	555	-	nm
Rise time *3	tr1	E _v =100 to 55000lx R=27kΩ	-	-	150	us
	tr2	E _v =3 to 55000lx R=27kΩ	-	-	5	ms
Fall time *3	tf1	E _v =100 to 55000lx R=27kΩ	-	-	150	us
	tf2	E _v =3 to 55000lx R=27kΩ	-	-	15	ms
Output current difference *4	ΔI	I _o (incandescent lamp E _v =100lx) -I _o (fluorescent lamp E _v =100lx) *4	-2	-	2	μA

*1: E_v: Illuminance by CIE standard light source A (tungsten lamp)

*2: Sensor output vs. illuminance is logarithmic.

$$I_o = 10 \times \log(E_v) \quad (\mu A)$$

*3: E_v: Illuminance by white LED.

*4: White LED is used on mass production line instead of fluorescent lamp.

REFERENCE

4. Reliability

The reliability of products shall satisfy items listed below.

Confidence level : 90%

LTPD : 10 or 20

Test Items	Test Conditions	Failure Judgment Criteria	Samples (n)
			Defective(C)
Temperature cycling	1 cycle -40°C ← → +85°C (30min) (30min) 20 cycles test	$I_{cc} < L \times 0.8$ $I_{cc} > U \times 1.2$ $I_{o1} < L \times 0.8$ $I_{o1} > U \times 1.2$ $I_{o2} < L \times 0.8$ $I_{o2} > U \times 1.2$ U: Upper specification limit L: Lower specification limit	n=22, C=0
High temp. and high humidity storage	+60°C, 90%RH, 500h		n=22, C=0
High temp. storage	+85°C, 500h		n=22, C=0
Low temp. storage	-40°C, 500h		n=22, C=0
Operation test	$V_{CC}=3.2V$, $T_a=+25^\circ C$, $E_v=3000lx$ 500h		n=22, C=0
Mechanical shock	1000m/s ² , 6ms, Half sine wave 3 times/±X, ±Y, ±Z direction		n=11, C=0
Variable frequency vibration	100 to 2000 to 100Hz/Sweep for 4min 200m/s ² , 48min/X, Y, Z direction		n=11, C=0
Soldering heat	250°C, 10 s, 2 times The temperature profile is according to the precautions for soldering (attachment-1).		n=11, C=0

REFERENCE

5. Outgoing inspection

(1) Inspection lot

Inspection shall be carried out per each delivery lot.

(2) Inspection method

A single sampling plan, normal inspection level II based on ISO2859 shall be adopted.

Parameter	Inspection items and test method				AQL(%)			
Major defect	1	Disconnection, short				0.1		
	2	Inverse polarity on terminal						
	3	Characteristics defect						
			Parameter	Symbol	Judgment criteria		Unit	
					MIN.		MAX.	
			Supply current	Icc	40		150	μA
			Output current 1	Io1	16		24	μA
	Output current 2	Io2	27	33	μA			
	Output current 3	Io3	-	1	μA			
	Measurement conditions are described in 3.3.							
Minor defect	1	Appearance defect				0.25		
			Parameter	Judgment criteria				
			Crack	Visible crack irrespective of its position shall be defect.				
			Split, Chip, Scratch, Stain	One which affects the characteristics of paragraph 3.3. shall be defect.				
	Bubble, Foreign matter(One on resin surface which can wipe off shall not be applied.)	One which is more than 1.0mm ϕ or one which affects the characteristics of paragraph 3.3. , shall be defect.						

REFERENCE

6. Supplement

(6-1) Circuit block diagram

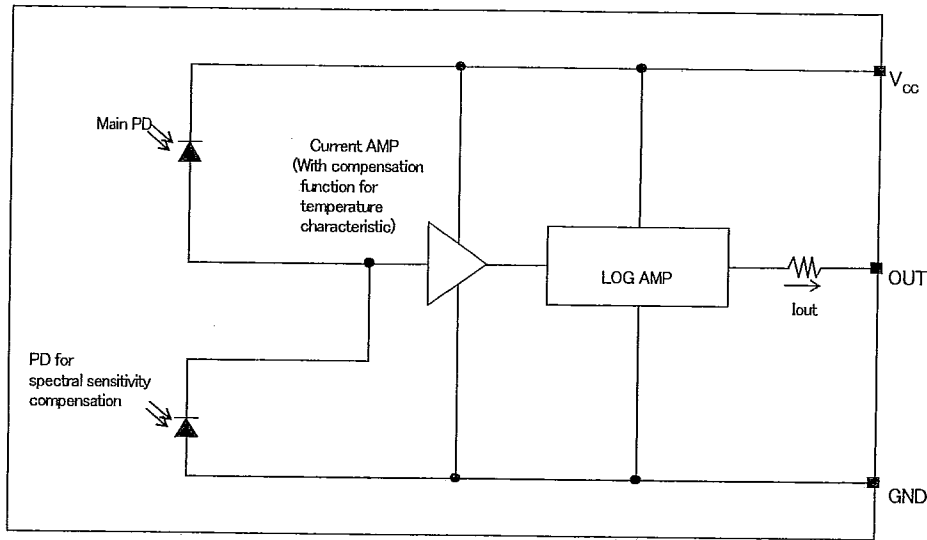

(6-2) Output Current Characteristic

Output Current Characteristics (TYP.)

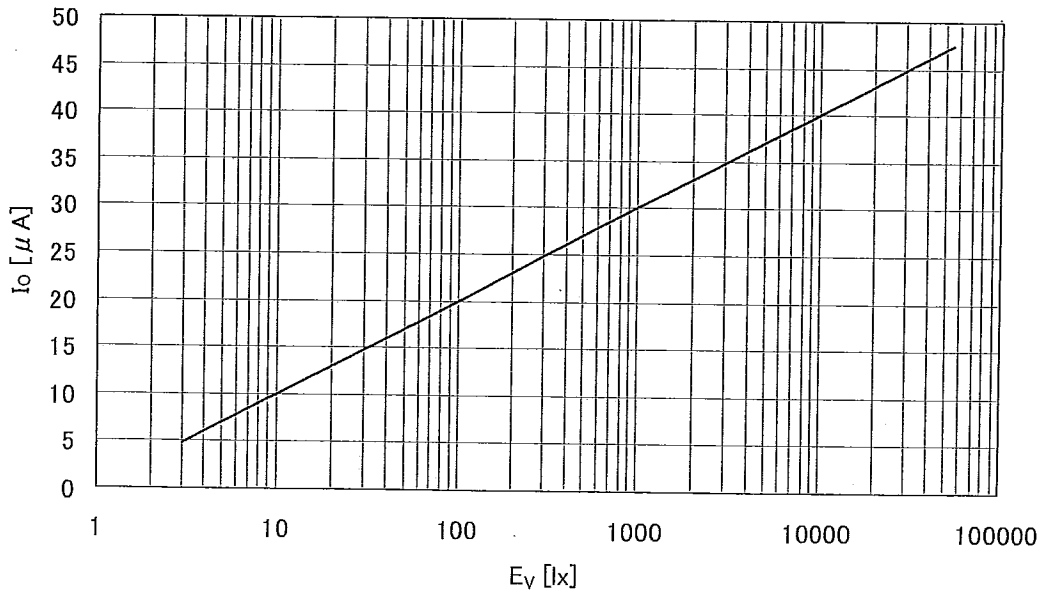

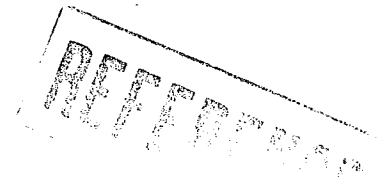

(Attachment-1-1)

Precautions for Soldering GA1A1S203WP

1. In case, solder reflow

Please do two times or less soldering at the temperature and the time within the temperature profile as shown in the figure below.

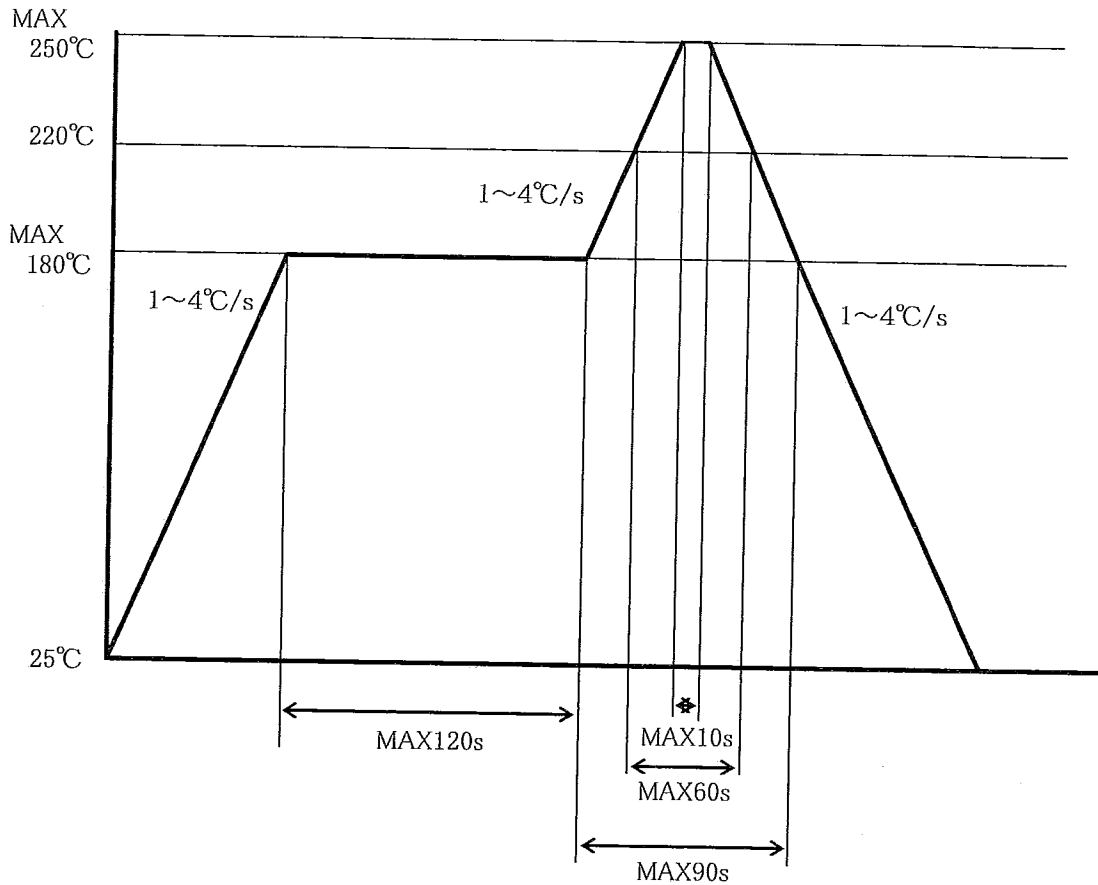

2. Other precautions

An infrared lamp used to heat up for soldering may cause a localized temperature rise in the resin.
So keep the package temperature within that specified in Item 1.

Please be careful not to give the mechanical force to the package when soldering
because it may cause the deformation or defect due to the plated connection.

Even if within the temperature profile above, there is the possibility that the
gold wire in package is broken in case that the deformation of PCB gives the affection to terminals.
Please use after confirming the conditions fully by actual solder reflow machine.

REFERENCE

(Attachment-1-2)

3. Storage and management after opening the package

3.1 Storage condition : Storage shall be in accordance with the below conditions.

Storage temp. : 5 to 30°C

Storage humidity : 70%RH or less

3.2 Treatment after opening the package

(1) After opening the package, please mount at the conditions of humidity 60%RH or less and temperature 5 to 25°C within 3 days.

(2) In case of long time storage after opening the package, please mount within 2 weeks at the conditions of (A) or (B).

(A) after resealing with desiccant in moisture-proof sack by sealer, keeping in the condition of humidity 70%RH or less and temperature 5 to 30°C

(B) keeping in the dry box (humidity 20% or less, temperature 5 to 25°C)

3.3 Baking before mounting

In case that it could not be carried out the above treatment, or the humidity indicator card turned pink when opening the package, it is able to mount by baking treatment. However baking treatment shall be limited only 1 time.

Recommended conditions : 125°C, 16 to 24 hours

Recommended conditions at the packaged condition by the reel : 65°C, 48 hours

※ In the case baking at the packaged condition, please hang the reel in the oven using the spindle through the center half of the reel. Please do not put the reel across the oven.



(Attachment-2-1)

Package specifications (ϕ 180mm reel)

1. Application

This specification applies to the taping specifications and the relation items for the GA1A1S203WP.
2. Taping method
 - (2.1) Tape structure and Dimensions (Refer to the attached sheet-2-2)

The tape shall have a structure in which a cover tape is sealed heat-pressed on the carrier tape made by electrically conductive polycarbonate to protect against static electricity.
 - (2.2) Reel structure and Dimensions (Refer to the attached sheet-2-3)

The reel shall be made of plastic.
 - (2.3) Direction of product insertion (Refer to the attached sheet-2-3)

Product direction in carrier tape shall direct to the Io and Vcc terminal (= the part of the cutout of the package) at the hole side on the tape, shall direct to the terminal part of the product at the bottom side of the rectangle hole on the tape, shall direct to the detecting part at the upside of the rectangle hole on the tape.
 - (2-4) Inclusion correction

In case correcting inclusion failing products, these products can be cut out from the carrier tape and the cutting parts can be sealed. At this time, the products are not included at the same places.
3. Adhesiveness of cover tape

The exhalation force between carrier tape and cover tape shall be 0.1N to 1.0N for the angle from 160° to 180° .
4. Rolling method and quantity

Wind the tape back on the reel so that the cover tape will be outside the tape.
 Attach more than 16cm of blank tape to the trailer and 40cm to the leader of the tape and fix the both ends with adhesive tape.
 One reel shall contain 2000 pcs, but in the case products by failing to seal are cut out(refer to the 2-4), the number is less.
5. Marking

The outer packaging case shall be marked with following information.
 * Model No. * Number of pieces delivered * Production date
6. Safety protection during shipping

There shall be no deformation of component or degradation of electrical characteristics due to shipping.

REFERENCE

(Attachment-2-2)

Tape structure and Dimensions

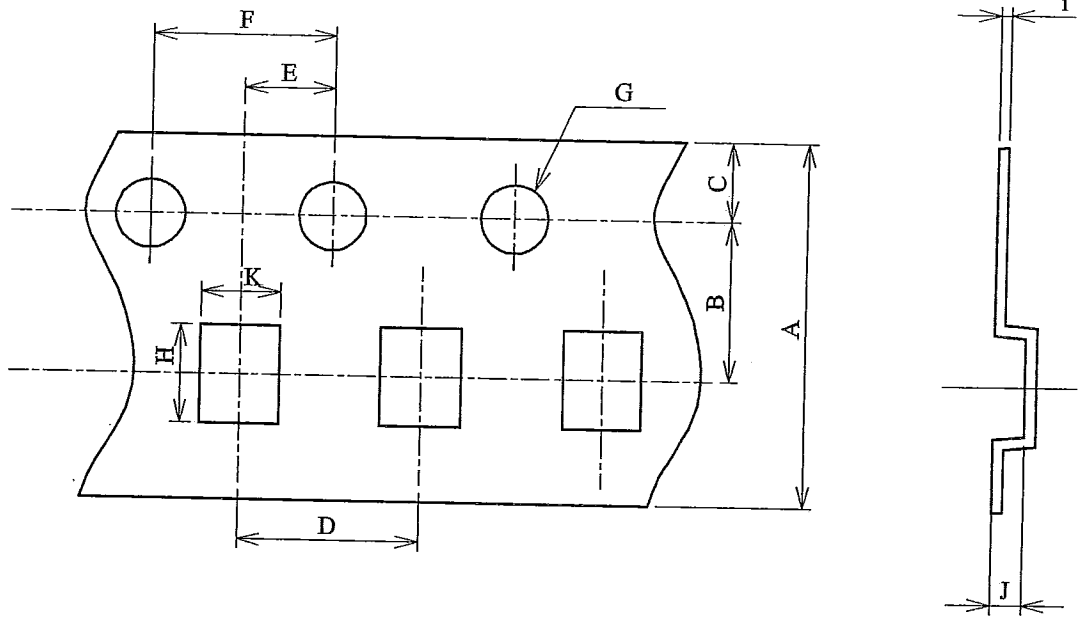

Unit \ Symbol	A	B	C	D	E	F
mm	8.0±0.1	3.5±0.1	1.75±0.10	4.0±0.1	2.0±0.1	4.0±0.1

Unit \ Symbol	G	H	i	J	K
mm	$\phi 1.5 \begin{smallmatrix} +0.1 \\ -0 \end{smallmatrix}$	2.12±0.10	0.25±0.10	0.70±0.10	1.70±0.10

REFERENCE

(Attachment-2-3)

Reel structure and Dimensions

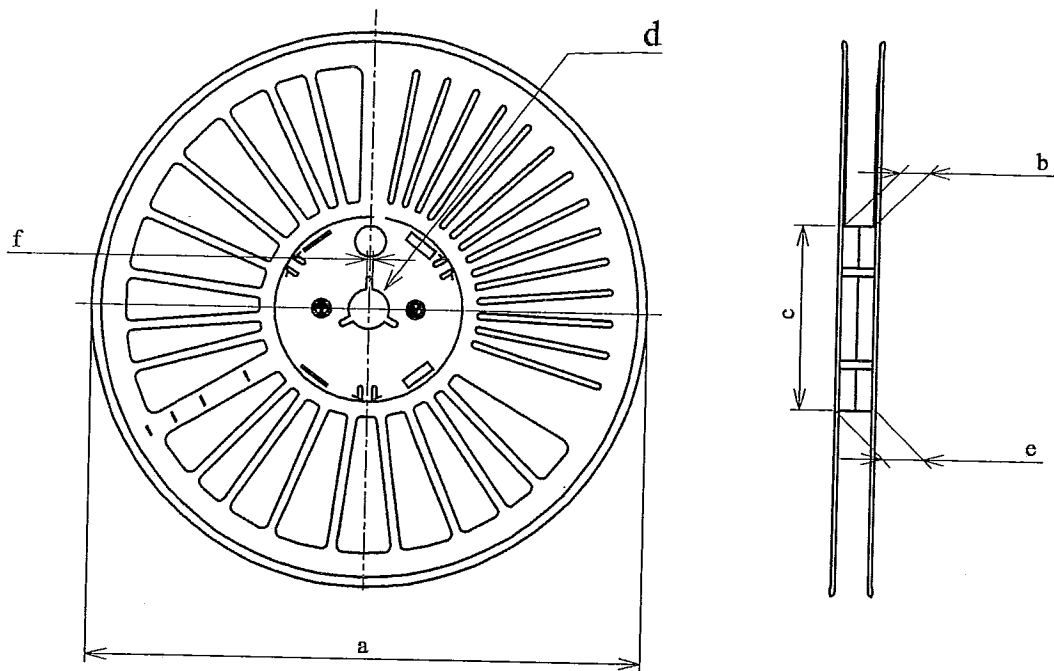

Unit	Symbol	a	b	c	d	e	f
mm		$\phi 180 \pm 1$	9.5 ± 1.0	$\phi 60 \pm 1$	13.0 ± 0.2	13.1 ± 1.0	2.0 ± 0.5

Direction of product insertion

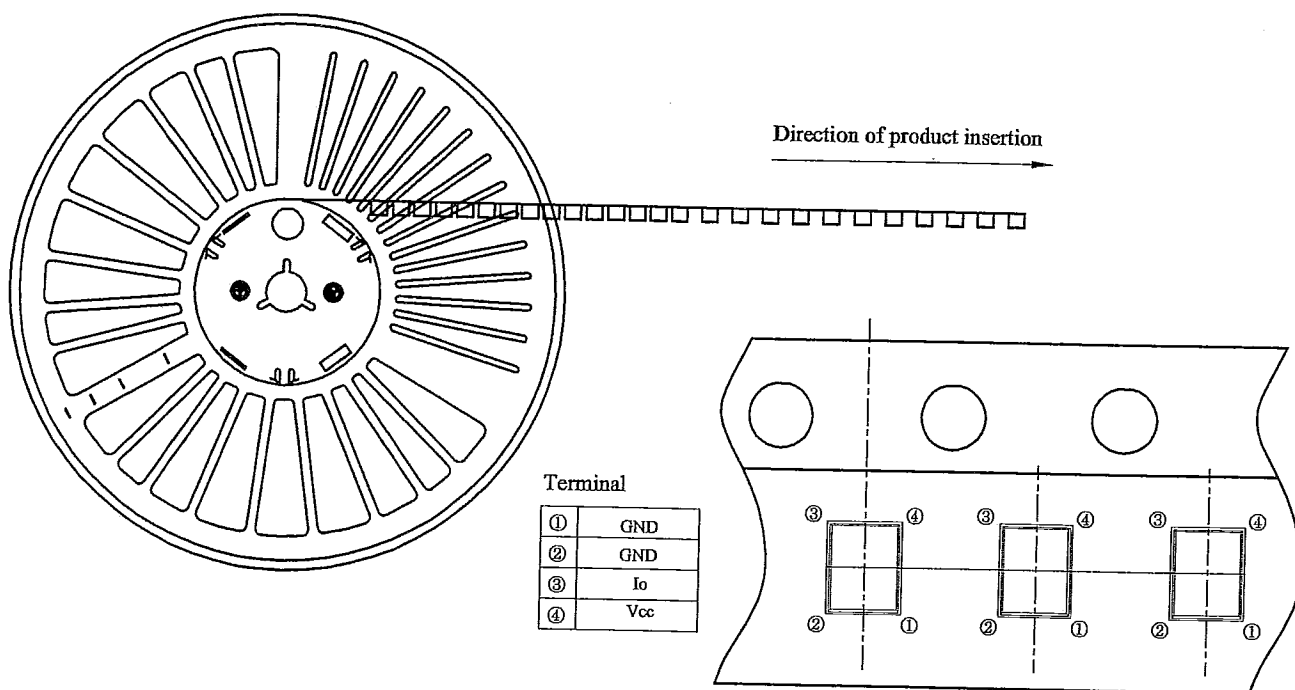

REFERENCE

(Attachment-2-4)

Moisture-proof package specification (ϕ 180mm reel)

1. Application

This specification applies to the products which Sharp delivers to customer.

2. Packing specifications

2.1 Packaging material

Name	Material	Quantity	Aim
Aluminum laminated bag	Aluminum polyethylene	Refer to 2.2	Moisture-proof
Label	Paper(-made)	-	Indication of Model No. and Quantity
Humidity indicator card	Paper(-made)	1 sheet / reel	Indication of Humidity

2.2 Packaging method

- (1) Seal the aluminum laminated bag included the ruled tape-reel and humidity indicator card quantity.
- (2) Fill up the blank of label and paste on the bag.
- (3) Put the moisture-proof laminated bag in the ruled case

Package shape	Product	Quantity	Moisture-proof sack Quantity
Tape-reel (ϕ 180mm)	1ch. type	2000pcs. / reel	1 reel / bag

Minimum order Quantity : 1 reel / bag

- (4) Packing case is closed by craft tape and Model No., Quantity, and Inspection date are filled out.
(Quantity: 10,000pcs./case) *Except the case products by failing to seal are cut out.

3. Storage and management after opening the package

3.1 Storage condition : Storage shall be in accordance with the below conditions.

Storage temp. : 5 to 30°C

Storage humidity : 70%RH or less

3.2 Treatment after opening the package

- (1) After opening the package, please mount at the conditions of humidity 60%RH or less and temperature 5 to 25°C within 3 days.
- (2) In case of long time storage after opening the package, please mount within 2 weeks at the conditions of (A) or (B).
(A) after resealing with desiccant in moisture-proof sack by sealer, keeping in the condition of humidity 70%RH or less and temperature 5 to 30°C
(B) keeping in the dry box (humidity 20% or less, temperature 5 to 25°C)

3.3 Baking before mounting

In case that it could not be carried out the above treatment, or the humidity indicator card turned pink when opening the package, it is able to mount by baking treatment. However baking treatment shall be limited only 1 time.

Recommended conditions : 125°C, 16 to 24 hours

Recommended conditions at the packaged condition by the reel : 65°C, 48 hours

- ※ In the case baking at the packaged condition, please hang the reel in the oven using the spindle through the center hall of the reel. Please do not put the reel across the oven.

REFERENCE

4 Packaging

① Outer packing drawing

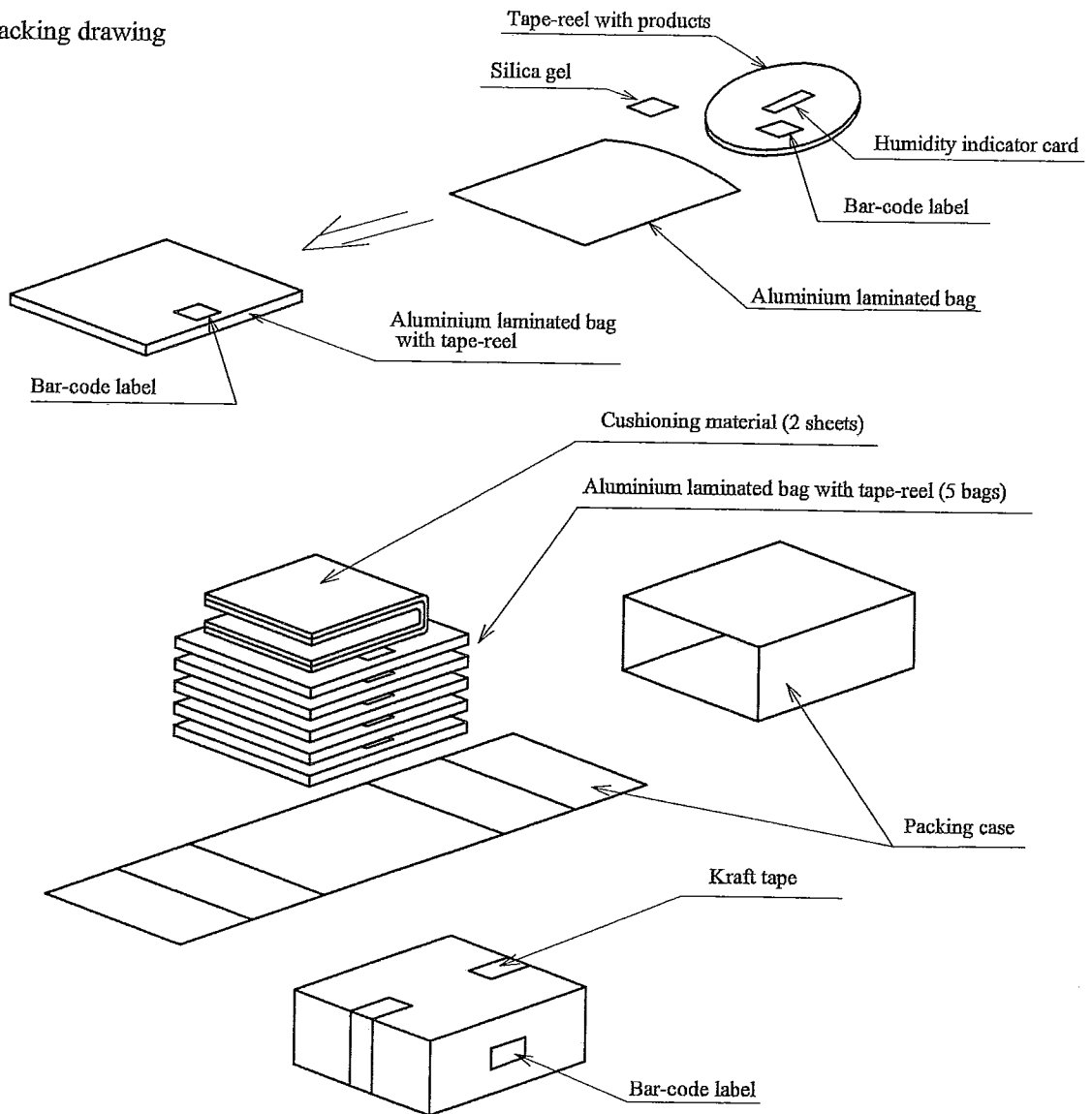

- ② Outer packing material: Packing case(Corrugated cardboard), Cushioning material (Urethane)
Aluminium laminated bag (Alumi-Polyethylene)
Humidity indicator card (paper), Label(paper), Silica gel, Kraft tape
- ③ Quantity: 10,000pcs./box
- ④ Indication: Model No., quantity and inspection date
- ⑤ Regular packaged mass: Approximately 600g