

High Visibility Color Knobs

450-3180-GRX, 450-3181-GRX,
450-3182-GRX, 450-3183-GRX

Date Last Revised: 11-17-08

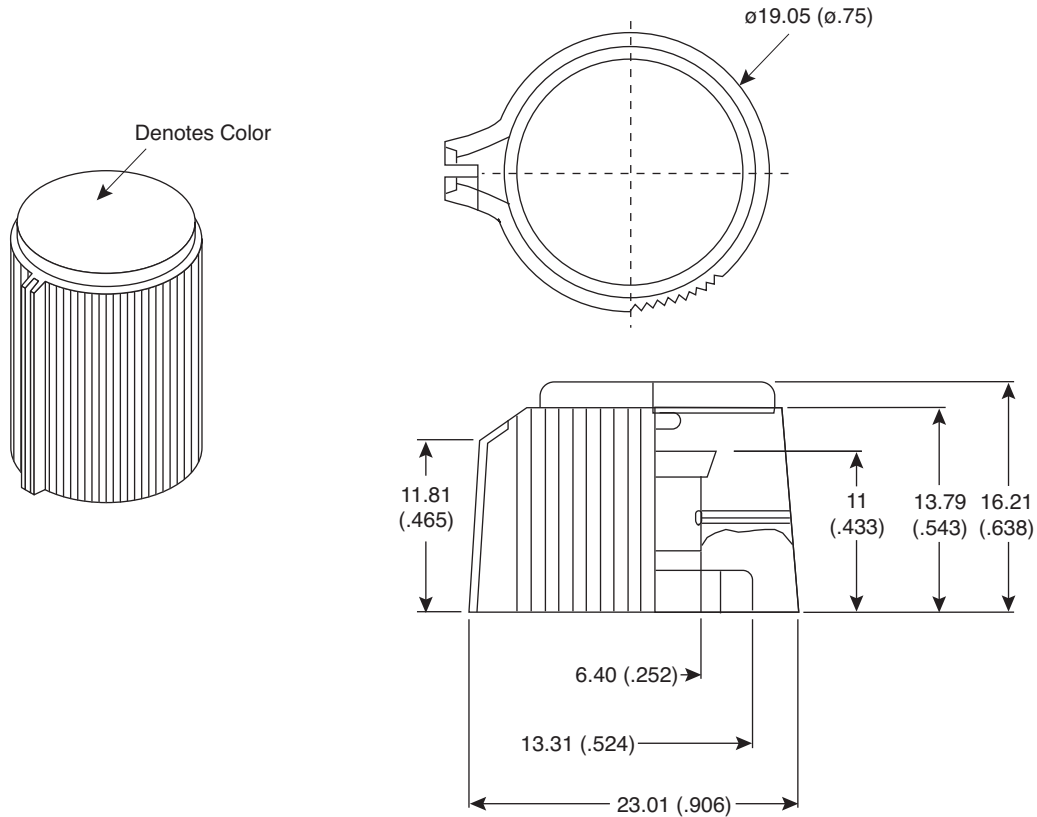

Dimensions: mm (in.)

SPECIFICATIONS	
Material of Body:	Phenolic resin
Color of Body:	Black
Indicator Type:	Painted white line
Insert:	Zinc
Shaft:	.25"
Colors (Top of Knob):	450-3180-GRX (Green), 450-3181-GRX (Red), 450-3182-GRX (Yellow), 450-3183-GRX (Blue)
RoHS Compliant by Exemption	

Available from Mouser Electronics
1-800-346-6873 / www.mouser.com

EPD-200533