

PHOENIX CONTACT CLIPLINE COMPLETE - Four Terminal Block Technologies, One Common Line of Accessories



ST SPRING TERMINAL SPRING-CAGE CONNECTION

The proven connection system for vibration-sensitive applications. The spring cage always exerts a constant force on the conductor regardless of the operator actions. Wiring is simple and is performed via the space-saving front connection.

2-Conductor Feed-Thru Terminal Blocks

• RoHS Compliant per Phoenix Documentation

For quantities of 500 and up, call for quote.

MOUSER STOCK NO.		Phoenix Type	Fig.	Color	AWG	Voltage Rating	Current Rating	Dimensions (mm)			Price Each			
Mfr.	Mfr. Part No.							H	L	W	1	10	50	100
651	—3031076	ST 1.5	A	Gray	26-14	300	15A	36.5	48.5	4.2	1.16	1.05	.992	.909
651	—3031212	ST 2.5	A	Gray	26-12	600	20A	36.5	48.5	5.2	1.28	1.15	1.10	.99
651	—3031364	ST 4	A	Gray	20-10	600	30A	36.5	56.0	6.2	1.51	1.36	1.28	1.18
651	—3031487	ST 6	A	Gray	20-8	600	50A	43.5	69.5	8.2	2.20	1.98	1.86	1.72
651	—3036110	ST 10	A	Gray	16-6	600	65A	50.5	71.5	10.2	2.69	2.47	2.28	2.14



3-Conductor Feed-Thru Terminal Blocks

• RoHS Compliant per Phoenix Documentation

For quantities of 500 and up, call for quote.

MOUSER STOCK NO.		Phoenix Type	Fig.	Color	AWG	Voltage Rating	Current Rating	Dimensions (mm)			Price Each			
Mfr.	Mfr. Part No.							H	L	W	1	10	50	100
651	—3031128	ST 1.5-TWIN	B	Gray	26-14	300	15A	36.5	60.5	4.2	1.31	1.13	1.01	.989
651	—3031131	ST 1.5-TWIN BU	B	Blue	26-14	300	15A	36.5	60.5	4.2	1.26	1.08	1.01	.978
651	—3031241	ST 2.5-TWIN	B	Gray	26-12	600	20A	36.5	60.5	5.2	1.48	1.27	1.19	1.15
651	—3031393	ST 4-TWIN	B	Gray	20-10	600	30A	36.5	71.5	6.2	1.57	1.34	1.26	1.23



Double Level Feed-Thru Terminal Blocks

• RoHS Compliant per Phoenix Documentation

For quantities of 500 and up, call for quote.

MOUSER STOCK NO.		Phoenix Type	Fig.	Color	AWG	Voltage Rating	Current Rating	Dimensions (mm)			Price Each			
Mfr.	Mfr. Part No.							H	L	W	1	10	50	100
651	—3031157	STTB 1.5	C	Gray	26-14	300	15A	47.5	67.5	4.2	1.98	1.68	1.59	1.52
651	—3031270	STTB 2.5	C	Gray	26-12	300	20A	47.5	67.5	5.2	3.00	2.55	2.38	2.34
651	—3031429	STTB 4	C	Gray	20-10	300	30A	47.5	83.5	6.2	3.16	2.68	2.50	2.46



Ground Terminal Blocks

• RoHS Compliant per Phoenix Documentation

For quantities of 500 and up, call for quote.

MOUSER STOCK NO.		Phoenix Type	Fig.	Color	AWG	Voltage Rating	Current Rating	Dimensions (mm)			Price Each			
Mfr.	Mfr. Part No.							H	L	W	1	10	50	100
651	—3031513	ST 1.5-PE	D	Gr/Yel	26-14	---	---	36.5	48.5	4.2	3.85	3.26	3.06	3.00
651	—3031238	ST 2.5-PE	D	Gr/Yel	26-12	---	---	36.5	48.5	5.2	4.60	4.12	3.93	3.57
651	—3031380	ST 4-PE	D	Gr/Yel	20-10	---	---	36.5	56.0	6.2	4.63	4.15	3.66	3.60
651	—3031500	ST 6-PE	D	Gr/Yel	20-8	---	---	43.5	69.5	8.2	5.78	4.88	4.60	4.51
651	—3036136	ST 10-PE	D	Gr/Yel	16-6	---	---	50.5	71.5	10.2	6.60	5.94	5.25	5.14
651	—3031144	ST 1.5-TWIN-PE	D	Gr/Yel	26-16	---	---	36.5	60.5	4.2	4.81	4.07	3.81	3.74
651	—3031267	ST 2.5-TWIN-PE	D	Gr/Yel	26-12	---	---	36.5	60.5	5.2	5.22	4.43	4.15	4.07
651	—3031416	ST 4-TWIN-PE	D	Gr/Yel	20-10	---	---	36.5	71.5	6.2	5.39	4.58	4.28	4.20
651	—3031209	ST 1.5-QUATTRO-PE	D	Gr/Yel	26-16	---	---	36.5	72.0	4.2	5.11	4.61	4.07	3.99
651	—3031322	ST 2.5-QUATTRO-PE	D	Gr/Yel	26-12	---	---	36.5	72.0	5.2	6.81	5.82	5.46	5.29
651	—3031461	ST 4-QUATTRO-PE	D	Gr/Yel	20-10	---	---	36.5	87.0	6.2	6.87	5.88	5.52	5.33
651	—3036013	STTB 1.5-PE	D	Gr/Yel	26-14	---	---	47.5	67.5	4.2	6.52	5.51	5.18	5.08
651	—3036026	STTB 2.5-PE	D	Gr/Yel	26-12	---	---	47.5	67.5	5.2	9.29	7.87	7.37	7.25
651	—3036039	STTB 4-PE	D	Gr/Yel	20-10	---	---	47.5	83.5	6.2	9.79	8.82	8.27	7.63
651	—3036440	STS 4-PE	D	Gr/Yel	24-10	---	---	50.5	64.5	6.2	4.62	4.15	3.95	3.59
651	—3038147	STS 6-PE	D	Gr/Yel	24-8	---	---	57.5	58.0	8.2	5.79	5.20	4.94	4.50



Fuse Terminal Blocks

• RoHS Compliant per Phoenix Documentation

* The max. load current must be < the total current of all connected conductors.

For quantities of 500 and up, call for quote.

MOUSER STOCK NO.		Phoenix Type	Fig.	Color	AWG	Voltage Rating	Current Rating	Dimensions (mm)			Price Each			
Mfr.	Mfr. Part No.							H	L	W	1	10	50	100
651	—3036385	ST 4-HESI(6.3X32)	E	Black	24-10	400	10A	69.0	76.5	8.2	6.79	6.36	6.05	5.83
651	—3036369	ST 4-HESI(5X20)	E	Black	24-10	300	6A	62.5	61.5	6.2	5.82	5.44	5.01	4.97



QT QUICKON TERMINAL FAST CONNECTION

Connect the conductor without having to strip it first. The quick connection system permits a drastic reduction of anything up to 60% in wiring time. The conductor connection is simple, reliable and fast, requiring only the aid of a standard screw driver.

• RoHS Compliant per Phoenix Documentation

For quantities of 500 and up, call for quote.

MOUSER STOCK NO.		Phoenix Type	Fig.	Color	AWG	Voltage Rating	Current Rating	Dimensions (mm)			Price Each			
Mfr.	Mfr. Part No.							H	L	W	1	10	50	100
651	—3205019	QTC 1.5	F	Gray	24-16	800	17.5A	39.3	58.8	5.2	1.34	1.21	1.14	1.03
651	—3205022	QTC 1.5 BU	F	Blue	24-16	800	17.5A	39.3	58.8	5.2	1.34	1.21	1.14	1.03
651	—3206416	QTC 2.5	F	Gray	20-14	800	24A	39.3	62.6	6.2	1.54	1.41	1.30	1.19
651	—3206429	QTC 2.5 BU	F	Blue	20-14	800	24A	39.3	62.6	6.2	1.54	1.41	1.30	1.18
651	—3205077	QTC 1.5-QUATTRO	G	Gray	24-16	800	17.5A*	39.3	94.0	5.2	2.44	2.19	2.07	1.89
651	—3205080	QTC 1.5-QUATTRO BU	G	Blue	24-16	800	17.5A*	39.3	94.0	5.2	2.09	1.99	1.93	1.89
*The max. load current must be < the total current of all connected conductors.														
Ground IDC Terminal Blocks														
651	—3205035	QTC 1.5-PE	H	Gr/Yel	24-16	---	---	39.3	58.8	5.2	4.48	4.02	3.82	3.48
651	—3205064	QTC 1.5-TWIN-PE	H	Gr/Yel	24-16	---	---	39.3	76.4	5.2	5.57	4.99	4.75	4.32
651	—3205093	QTC 1.5-QUATTRO-PE	H	Gr/Yel	24-16	---	---	39.3	94.0	5.2	5.91	5.30	5.04	4.59

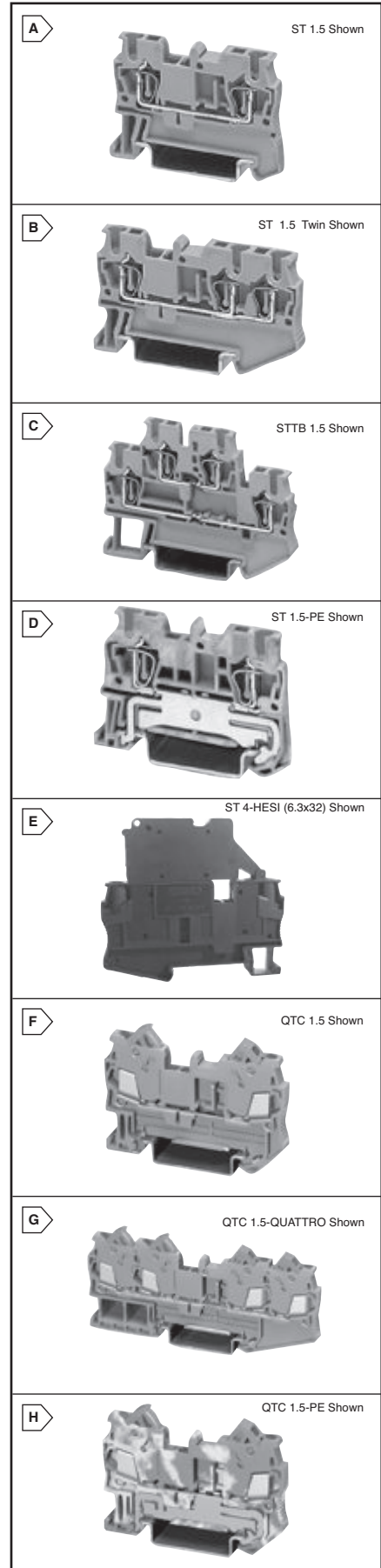

Terminal Blocks Phoenix Contact