

PARALLAX 32 Bit and 8 Bit Microcontrollers

Products may be RoHS compliant. Check mouser.com for RoHS status.



PROPELLER by Parallax, Inc.

32 BIT PROPELLER MULTICORE MICROCONTROLLERS

What can you do with eight 32-bit processors (COGs) in one chip? Real simultaneous multi-processing!

The new Propeller chip is the result of our internal design team working for eight years. The Propeller chip was designed at the transistor level by schematic using our own Altera Stratix tools to prototype the product. The Propeller is programmed in both a high-level language, called Spin™, and low-level (assembly) language. With the set of pre-built Parallax "objects" for video, mice, keyboards, RF, LCDs, stepper motors and sensors your Propeller application is a matter of high-level integration. The Propeller is recommended for those with previous microcontroller experience.

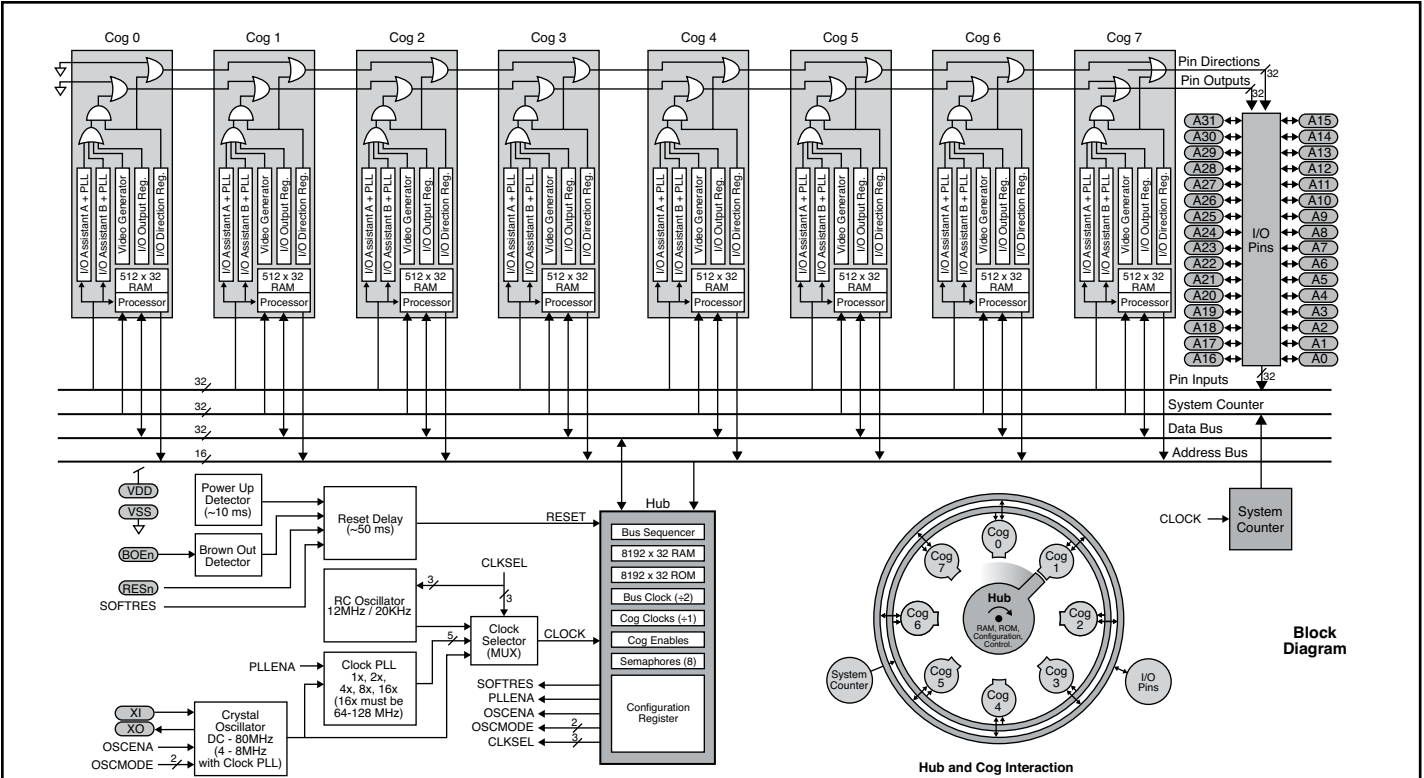

Propeller Specifications	
Model Number	P8X32A
Package Types	40-pin DIP, 44-pin LQFP, 44-pin QFN
Parallax Stock Codes	P8X32A-D40 - DIP package P8X32A-Q44 - LQFP package P8X32A-M44 - QFN package
Power Requirements	3.3 volts DC
External Clock Speed	DC to 80 MHz (4 MHz to 8 MHz with Clock PLL running)
Internal RC Oscillator	12 MHz or 20 KHz
System Clock Speed	DC to 80 MHz
Global RAM/ROM	64 K bytes; 32K RAM / 32K ROM
RAM/ROM Organization	32 bits (4 bytes or 1 long)
I/O Pins	32
Current Source/Sink per I/O	50 mA

Propeller Microcontrollers		For quantities greater than listed, call for quote.					
MOUSER STOCK NO.	Parallax Part No.	Package	Size (mm)	Price Each			
				1	10	25	100
619-P8X32A-D40	P8X32A-D40	40 Pin DIP	51 x 12.3	7.99	7.55	7.47	7.45
619-P8X32A-M44	P8X32A-M44	44 Pin QFN	9 x 9	7.99	7.99	7.99	7.99
619-P8X32A-Q44	P8X32A-Q44	44 Pin LQFP	10 x 10	7.99	7.48	7.40	7.32

Propeller Development Tools / Kits		Description	Price Each
MOUSER STOCK NO.	Parallax Part No.		
619-32300	32300	Propeller Starter Kit	99.99
619-32100	32100	Propeller Demo Board	79.98
619-32311	32311	Propeller Access. Kit - PS/2 Keyboard/Mouse & 2.5" LCD Display	109.65
619-40000	40000	Propeller Quickstart Board for PBX32A	30.00
619-122-32000	122-32000	Propeller Manual	34.95

Propeller Starter Kit

The Propeller Starter Kit includes everything you need to get started with the Propeller microcontroller, including the Propeller Demo Board, the Propeller Manual, software on CD and a USB cable. The Propeller Demo Board includes a built-in Propeller (P8X32A-Q44), EEPROM and 5 MHz crystal pre-wired to connectors for interfacing to devices such as a mouse, keyboard, TV or VGA monitor and speakers. This is all configured for immediate use by many objects from the Propeller Object Exchange (included with the Propeller Tool software). In just a few minutes you can see some of the impressive tasks the Propeller can perform.



MOUSER STOCK NO.	Parallax Part No.	Description	Price Each
619-32300	32300	Propeller Starter Kit	99.99

Propeller Education Kit - PropStick USB Version

This kit features the PropStick USB, with built-in Propeller chip, EEPROM, regulator, crystal and programming connections so your project can get up and running with minimal wiring time. The Propeller Education Kit - 40-Pin DIP Version is also available.



MOUSER STOCK NO.	Parallax Part No.	Description	Price Each
619-32306	32306	Propeller Education Kit - PropStick USB Version	99.99

HYDRA Game Development Kit

Develop games, graphics and media applications with the Propeller Powered HYDRA Game Console. For beginner to intermediate coders, you need only basic programming experience in any BASIC or C-like language. All of the hardware and software you need is included (as shown in pictures), along with the comprehensive book on game programming for the Propeller in Spin and assembly language - "Game Programming for the Propeller Powered HYDRA". Within the book, the HYDRA hardware is covered in detail with schematics, descriptions, and tips allowing you to take full advantage of its resources, including its expansion port and game card. Note: Printed book is black and white.

Kit comes complete with HYDRA unit, book, 128K Memory card, Blank Experimenter card, mouse, keyboard, gamepad, video and USB cables, power supply, CD and more!



MOUSER STOCK NO.	Parallax Part No.	Description	Price Each
619-32360	32360	HYDRA Game Development Kit	158.65

Propeller Professional Development Board

The Propeller Professional Development Board (PPDB) is a high-quality, fully-integrated development platform for the Propeller microcontroller. A wide variety of typical I/O (LEDs, Buttons, etc.) devices and circuitry are built into the PPDB, providing the developer with an ideal platform for rapid Propeller project development.



MOUSER STOCK NO.	Parallax Part No.	Description	Price Each
619-32111	32111	Propeller Professional Development Board	157.84