

# NOVACAP Ceramic SMD Capacitors



This product is RoHS compliant.

## NOVACAP SMD CERAMIC CAPACITORS

(EIA COG) or NPO Dielectric is an ultra stable Class I dielectric. It has a linear temperature coefficient, low loss, stable electrical properties with time, voltage and frequency. COG chips are used in precision circuitry requiring Class I stability. X7R Dielectric is a stable EIA Class II dielectric, with +/-15% temperature coefficient and predictable variation of electrical properties with time, temperature and voltage. Class II X7R chips are used as decoupling, by-pass, filtering and transient voltage suppression elements. Y5V/Z5U Dielectric is a general purpose EIA Class III dielectrics with +22% to -56% (Z5U) and +22% -82% (Y5V) temperature coefficients and very high capacitance density. The NOVACAP Z5U and Y5V formulations are very stable with time, typically aging less than 2% per decade. General purpose chips are used in by-pass and decoupling functions and other applications where capacitance change over the operating temperature range is not critical.

All Dielectrics are available in two nickel barrier termination systems suitable for solder wave, vapor phase or reflow solder board attachment. The "N" termination is a standard nickel barrier over fired on silver. The "C" termination is a nickel barrier over polymer terminated capacitors, which are able to accommodate a significantly increased degree of board flexure compared with standard terminated capacitors.

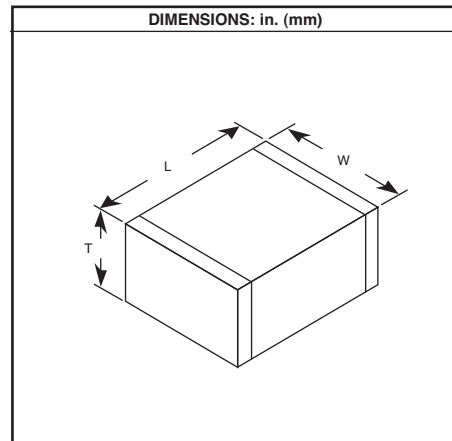

For quantities of 4,000 and up, call for quote.

Size	0603	0805	1206	1210	1515	1808	1812
(L) Length	0.060 (1.52)	0.080 (2.03)	0.125 (3.18)	0.125 (3.18)	0.150 (3.81)	0.180 (4.57)	0.180 (4.57)
(W) Width	0.030 (.762)	0.050 (1.27)	0.060 (1.52)	0.100 (2.54)	0.150 (3.81)	0.080 (2.03)	0.125 (3.18)

MOUSER STOCK NO.	Novacap Part Number	Dielectric	Value (pF)	Voltage	Tol. (±)	Thickness Max. (T)	Price Each			Reel Qty	Price Each
							1	10	100		
<b>0603</b>											
767-0603B102K201CT	0603B102K201CT	X7R	1000	200	10%	0.035 (0.889)	.46	.39	.36	500	.29
<b>0805</b>											
767-0805B102K201CT	0805B102K201CT	X7R	1000	200	10%	0.054 (1.37)	.46	.39	.36	500	.29
<b>1206</b>											
767-1206B471K202NT	1206B471K202NT	X7R	470	2000	10%	0.064 (1.63)	.88	.75	.69	500	.56
767-1206B471K501CT	1206B471K501CT	X7R	470	500	10%	0.064 (1.63)	.46	.39	.36	500	.29
767-1206B102K202NT	1206B102K202NT	X7R	1000	2000	10%	0.064 (1.63)	.88	.75	.69	500	.56
767-1206B472K501CT	1206B472K501CT	X7R	4700	500	10%	0.064 (1.63)	.60	.51	.47	500	.38
767-1206B103M501CT	1206B103M501CT	X7R	0.01µF	500	20%	0.064 (1.63)	.88	.75	.69	500	.56
767-1206B224K500CT	1206B224K500CT	X7R	0.22µF	50	10%	0.064 (1.63)	.88	.75	.69	500	.56
<b>1210</b>											
767-1210B471K202NT	1210B471K202NT	X7R	470	2000	10%	0.065 (1.65)	.91	.78	.72	500	.59
767-1210B102K202NT	1210B102K202NT	X7R	1000	2000	10%	0.065 (1.65)	.88	.75	.69	500	.56
767-1210N102J501NT	1210N102J501NT	COG	1000	500	5%	0.065 (1.65)	.88	.75	.69	500	.56
767-1210B472K152NT	1210B472K152NT	X7R	4700	1500	10%	0.065 (1.65)	.88	.75	.69	500	.56
767-1210N103F101NT	1210N103F101NT	COG	0.01µF	100	1%	0.065 (1.65)	3.33	2.85	2.61	500	2.14
767-1210B223K501NT	1210B223K501NT	X7R	0.022µF	500	10%	0.065 (1.65)	.88	.75	.69	500	.56
767-1210B473K251CT	1210B473K251CT	X7R	0.047µF	250	10%	0.065 (1.65)	.88	.75	.69	500	.56
767-1210B473K501CT	1210B473K501CT	X7R	0.047µF	500	10%	0.065 (1.65)	.91	.78	.72	500	.59
767-1210B473K501NT	1210B473K501NT	X7R	0.047µF	500	10%	0.065 (1.65)	.88	.75	.69	500	.56
767-1210B104K101CT	1210B104K101CT	X7R	0.1µF	100	10%	0.065 (1.65)	.88	.75	.69	500	.56
767-1210B104K201NT	1210B104K201NT	X7R	0.1µF	200	10%	0.065 (1.65)	.88	.75	.69	500	.56
767-1210B224K101NT	1210B224K101NT	X7R	0.22µF	100	10%	0.065 (1.65)	.88	.75	.69	500	.56
<b>1515</b>											
767-1515B102K202NT	1515B102K202NT	X7R	1000	2000	10%	0.130 (3.30)	1.75	1.50	1.38	500	1.13
<b>1808</b>											
767-1808B151K302NT	1808B151K302NT	X7R	150	3000	10%	0.065 (1.65)	.88	.75	.69	500	.56
767-1808B221K302NT	1808B221K302NT	X7R	220	3000	10%	0.065 (1.65)	.88	.75	.69	500	.56
767-1808B102K202NT	1808B102K202NT	X7R	1000	2000	10%	0.065 (1.65)	.88	.75	.69	500	.56
767-1808B152K202NT	1808B152K202NT	X7R	1500	2000	10%	0.065 (1.65)	.88	.75	.69	500	.56
767-1808B222M202NT	1808B222M202NT	X7R	2200	2000	20%	0.065 (1.65)	.88	.75	.69	500	.56
767-1808B103K102NT	1808B103K102NT	X7R	0.01µF	1000	10%	0.065 (1.65)	.88	.75	.69	500	.56
<b>1812</b>											
767-1812N151J302NT	1812N151J302NT	COG	150	3000	5%	0.065 (1.55)	1.75	1.50	1.38	500	1.13
767-1812N221J302NT	1812N221J302NT	COG	220	3000	5%	0.065 (1.55)	1.75	1.50	1.38	500	1.13
767-1812B471K302NT	1812B471K302NT	X7R	470	3000	10%	0.065 (1.55)	1.75	1.50	1.38	500	1.13
767-1812B102K202NT	1812B102K202NT	X7R	1000	2000	10%	0.065 (1.55)	1.75	1.50	1.38	500	1.13
767-1812B102K302NT	1812B102K302NT	X7R	1000	3000	10%	0.065 (1.55)	1.75	1.50	1.38	500	1.13
767-1812N102J202NT	1812N102J202NT	COG	1000	2000	5%	0.065 (1.55)	1.75	1.50	1.38	500	1.13
767-1812B222K202CT	1812B222K202CT	X7R	2200	2000	10%	0.065 (1.55)	1.75	1.50	1.38	500	1.13
767-1812B222K202NT	1812B222K202NT	X7R	2200	2000	10%	0.065 (1.55)	1.75	1.50	1.38	500	1.13
767-1812N222M202NXT	1812N222M202NXT	COG	2200	2000	20%	0.065 (1.55)	2.03	1.74	1.60	500	1.31
767-1812B472K202NT	1812B472K202NT	X7R	4700	2000	10%	0.065 (1.55)	1.75	1.50	1.38	500	1.13
767-1812B103K102NT	1812B103K102NT	X7R	0.01µF	1000	10%	0.065 (1.55)	1.75	1.50	1.38	500	1.13
767-1812N103J201NT	1812N103J201NT	COG	0.01µF	200	5%	0.065 (1.55)	1.75	1.50	1.38	500	1.13
767-1812B223K102NT	1812B223K102NT	X7R	0.022µF	1000	10%	0.065 (1.55)	1.75	1.50	1.38	500	1.13
767-1812B223K501CT	1812B223K501CT	X7R	0.022µF	500	10%	0.065 (1.55)	1.75	1.50	1.38	500	1.13
767-1812B273K102NT	1812B273K102NT	X7R	0.027µF	1000	10%	0.065 (1.55)	1.75	1.50	1.38	500	1.13
767-1812B473K102NXT	1812B473K102NXT	X7R	0.047µF	1000	10%	0.065 (1.55)	2.38	2.04	1.87	500	1.53
767-1812B104K201NT	1812B104K201NT	X7R	0.1µF	200	10%	0.065 (1.55)	1.75	1.50	1.38	500	1.13
767-1812B104K501NT	1812B104K501NT	X7R	0.1µF	500	10%	0.065 (1.55)	2.35	2.01	1.84	500	1.51
767-1812B224K251NT	1812B224K251NT	X7R	0.22µF	250	10%	0.065 (1.55)	2.00	1.71	1.57	500	1.28
767-1812B334K251CXT	1812B334K251CXT	X7R	0.33µF	250	10%	0.065 (1.55)	2.98	2.55	2.34	500	1.91
767-1812B474K101NT	1812B474K101NT	X7R	0.47µF	100	10%	0.065 (1.55)	2.49	2.13	1.95	500	1.60
767-1812Z105M500CT	1812Z105M500CT	Z5U	1µF	50	20%	0.065 (1.55)	1.75	1.50	1.38	500	1.13
767-1812B105K500NXT	1812B105K500NXT	X7R	1µF	50	10%	0.065 (1.55)	3.85	3.30	3.03	500	2.48
767-1812Y475M500CT	1812Y475M500CT	Y5V	4.7µF	50	20%	0.065 (1.55)	1.75	1.50	1.38	500	1.13