

# HAMMOND Power Transformers



## LOW VOLTAGE PC BOARD MOUNT UNIVERSAL

- 14 output voltages to choose from (5 - 36VAC R.M.S.)
- Six VA size models available from - 2.5 to 56VA
- Universal operation on 50/60Hz current, 115 or 230V dual primary
- Low profile, split bobbin with top shroud design
- Dual winding secondaries, non-concentrically wound
- Low primary to secondary coupling - no electrostatic shield required
- CSA certified (# LR3902) and UL recognized (# E50394)
- One year warranty
- High insulation - Hi-pot of 4,000V RMS
- Class F insulation - 155°C
- Two hole mounting on 2.5, 5, 10, and 20VA sizes, four hole mounting on 30 and 56VA size (mounting screws not provided)
- P.C. board mount with industry standard pin spacing

For quantities of 50 and up, call for quote.

MOUSER STOCK NO.	Hammond Part No.	Fig.	Size VA	Dimension: in.					Secondary (RMS)		Price Each			
				A	B	C	D	E	Series	Parallel	1	5	10	25
546-183E10	183E10	A	2.5	1.63	1.44	1.13	0.20	0.25	10V C.T. @ .25A	5V @ .5A	12.81	10.84	10.07	9.36
546-183F10	183F10	A	5	1.63	1.44	1.38	0.20	0.40	10V C.T. @ .5A	5V @ 1A	15.39	13.03	12.11	11.27
546-183G10	183G10	A	10	1.88	1.56	1.38	0.20	0.40	10V C.T. @ 1A	5V @ 2A	16.93	14.33	13.33	12.40
546-183H10	183H10	A	20	2.25	1.88	1.63	0.40	0.40	10V C.T. @ 2A	5V @ 4A	20.41	17.28	16.06	14.95
546-183J10	183J10	A	30	2.63	2.19	1.56	0.55	0.28	10V C.T. @ 3A	5V @ 6A	24.19	20.48	19.04	17.72
546-183K10	183K10	A	56	3.00	2.50	1.81	0.60	0.30	10V C.T. @ 5.6A	5V @ 11.2A	30.38	25.72	23.91	22.26
546-183E12	183E12	A	2.5	1.63	1.44	1.13	0.20	0.25	12.6V C.T. @ .2A	6.3V @ .4A	14.22	12.04	11.19	10.42
546-183F12	183F12	A	5	1.63	1.44	1.38	0.20	0.40	12.6V C.T. @ .4A	6.3V @ .8A	15.39	13.03	12.11	11.27
546-183G12	183G12	A	10	1.88	1.56	1.38	0.20	0.40	12.6V C.T. @ .8A	6.3V @ 1.6A	16.93	14.33	13.33	12.40
546-183H12	183H12	A	20	2.25	1.88	1.63	0.40	0.40	12.6V C.T. @ 1.6A	6.3V @ 3.2A	20.41	17.28	16.06	14.95
546-183J12	183J12	A	30	2.63	2.19	1.56	0.55	0.28	12.6V C.T. @ 2.4A	6.3V @ 4.8A	24.19	20.48	19.04	17.72
546-183K12	183K12	A	56	3.00	2.50	1.81	0.60	0.30	12.6V C.T. @ 4.4A	6.3V @ 8.8A	30.38	25.72	23.91	22.26
546-183E16	183E16	A	2.5	1.63	1.44	1.13	0.20	0.25	16V C.T. @ .15A	8V @ .3A	14.22	12.04	11.19	10.42
546-183F16	183F16	A	5	1.63	1.44	1.38	0.20	0.40	16V C.T. @ .31A	8V @ .62A	15.39	13.03	12.11	11.27
546-183G16	183G16	A	10	1.88	1.56	1.38	0.20	0.40	16V C.T. @ .62A	8V @ 1.25A	16.93	14.33	13.33	12.40
546-183H16	183H16	A	20	2.25	1.88	1.63	0.40	0.40	16V C.T. @ 1.25A	8V @ 2.5A	20.41	17.28	16.06	14.95
546-183J16	183J16	A	30	2.63	2.19	1.56	0.55	0.28	16V C.T. @ 1.9A	8V @ 3.8A	24.19	20.48	19.04	17.72
546-183K16	183K16	A	56	3.00	2.50	1.81	0.60	0.30	16V C.T. @ 3.5A	8V @ 7A	30.38	25.72	23.91	22.26
546-183E20	183E20	A	2.5	1.63	1.44	1.13	0.20	0.25	20V C.T. @ .12A	10V @ .24A	14.22	12.04	11.19	10.42
546-183F20	183F20	A	5	1.63	1.44	1.38	0.20	0.40	20V C.T. @ .25A	10V @ .5A	15.39	13.03	12.11	11.27
546-183G20	183G20	A	10	1.88	1.56	1.38	0.20	0.40	20V C.T. @ .5A	10V @ 1A	16.93	14.33	13.33	12.40
546-183H20	183H20	A	20	2.25	1.88	1.63	0.40	0.40	20V C.T. @ 1.0A	10V @ 2A	20.41	17.28	16.06	14.95
546-183J20	183J20	A	30	2.63	2.19	1.56	0.55	0.28	20V C.T. @ 1.5A	10V @ 3A	24.19	20.48	19.04	17.72
546-183K20	183K20	A	56	3.00	2.50	1.81	0.60	0.30	20V C.T. @ 2.8A	10V @ 5.6A	30.38	25.72	23.91	22.26
546-183E24	183E24	A	2.5	1.63	1.44	1.13	0.20	0.25	24V C.T. @ .1A	12V @ .2A	14.22	12.04	11.19	10.42
546-183F24	183F24	A	5	1.63	1.44	1.38	0.20	0.40	24V C.T. @ .21A	12V @ .42A	15.39	13.03	12.11	11.27
546-183G24	183G24	A	10	1.88	1.56	1.38	0.20	0.40	24V C.T. @ .42A	12V @ .84A	16.93	14.33	13.33	12.40
546-183H24	183H24	A	20	2.25	1.88	1.63	0.40	0.40	24V C.T. @ .83A	12V @ 1.66A	20.41	17.28	16.06	14.95
546-183J24	183J24	A	30	2.63	2.19	1.56	0.55	0.28	24V C.T. @ 1.25A	12V @ 2.5A	24.19	20.48	19.04	17.72
546-183K24	183K24	A	56	3.00	2.50	1.81	0.60	0.30	24V C.T. @ 2.33A	12V @ 4.66A	30.38	25.72	23.91	22.26
546-183E28	183E28	A	2.5	1.63	1.44	1.13	0.20	0.25	28V C.T. @ .09A	14V @ .18A	14.22	12.04	11.19	10.42
546-183F28	183F28	A	5	1.63	1.44	1.38	0.20	0.40	28V C.T. @ .18A	14V @ .36A	15.39	13.03	12.11	11.27
546-183G28	183G28	A	10	1.88	1.56	1.38	0.20	0.40	28V C.T. @ .36A	14V @ .72A	16.93	14.33	13.33	12.40
546-183H28	183H28	A	20	2.25	1.88	1.63	0.40	0.40	28V C.T. @ .72A	14V @ 1.44A	20.41	17.28	16.06	14.95
546-183J28	183J28	A	30	2.63	2.19	1.56	0.55	0.28	28V C.T. @ 1.06A	14V @ 2.12A	24.19	20.48	19.04	17.72
546-183K28	183K28	A	56	3.00	2.50	1.81	0.60	0.30	28V C.T. @ 2A	14V @ 4A	30.38	25.72	23.91	22.26
546-183E36	183E36	A	2.5	1.63	1.44	1.13	0.20	0.25	36V C.T. @ .07A	18V @ .14A	14.22	12.04	11.19	10.42
546-183F36	183F36	A	5	1.63	1.44	1.38	0.20	0.40	36V C.T. @ .14A	18V @ .28A	15.39	13.03	12.11	11.27
546-183G36	183G36	A	10	1.88	1.56	1.38	0.20	0.40	36V C.T. @ .28A	18V @ .56A	16.93	14.33	13.33	12.40
546-183H36	183H36	A	20	2.25	1.88	1.63	0.40	0.40	36V C.T. @ .56A	18V @ 1.12A	20.41	17.28	16.06	14.95
546-183J36	183J36	A	30	2.63	2.19	1.56	0.55	0.28	36V C.T. @ .82A	18V @ 1.64A	24.19	20.48	19.04	17.72
546-183K36	183K36	A	56	3.00	2.50	1.81	0.60	0.30	36V C.T. @ 1.56A	18V @ 3.12A	30.38	25.72	23.91	22.26

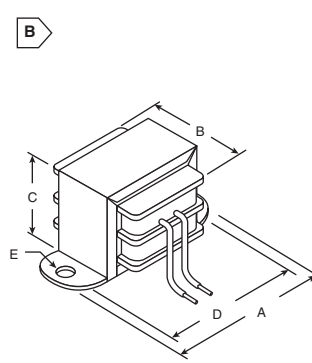
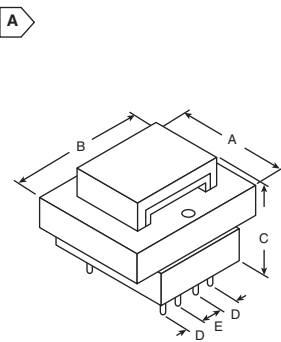

## OPEN STYLE FILAMENT AND L.V. RECTIFIER USE TRANSFORMERS

- Primary 115VAC, 60Hz
- All secondaries center tapped, VAC (RMS)
- Open style, channel bracket, two hole chassis mount
- Minimum 6" long leads
- Dual bobbin design - no electrostatic shield required
- Class B insulation (130°C)
- Hi-Pot test of 2,000 VRMS
- UL listed (#E50394) and CSA certified (#LR3902)

For quantities of 10 and up, call for quote.

MOUSER STOCK NO.	Hammond Part No.	Fig.	Secondary (RMS)		Dimension: in.					Price Each	
			VAC	Amps	A	B	C	D	E	1	5
546-166L5	166L5	B	5.0ct	2	2.81	1.63	1.69	2.38	.187	19.63	16.61
546-166MS	166MS	B	5.0ct	3	3.25	1.75	2.00	2.81	.187	19.63	16.61
546-166R5	166R5	B	5.0ct	8	3.69	2.00	2.31	3.13	.187	31.42	26.59
546-166RS	166RS	B	5.0ct	8	4.50	2.50	2.88	4.00	.203	31.42	26.59
546-166S5	166S5	B	5.0ct	10	3.69	2.13	2.31	3.13	.187	33.38	28.24
546-166U5	166U5	B	5.0ct	15	4.03	2.25	2.63	3.56	.187	43.20	36.55
546-166V5	166V5	B	5.0ct	20	4.50	2.50	2.88	4.00	.203	51.06	43.19
546-166J6	166J6	B	6.3ct	1	2.81	1.50	1.69	2.38	.187	15.70	13.29
546-166K6	166K6	B	6.3ct	1.2	2.81	1.50	1.69	2.38	.187	17.44	14.76
546-166L6	166L6	B	6.3ct	2	2.81	1.63	1.69	2.38	.187	21.82	18.47
546-166N6	166N6	B	6.3ct	4	3.25	1.75	2.00	2.81	.187	17.44	14.75
546-166Q6	166Q6	B	6.3ct	6	3.69	2.00	2.31	3.13	.187	29.45	24.92
546-166S6	166S6	B	6.3ct	10	4.03	2.25	2.63	3.56	.187	41.23	34.89
546-166E12	166E12	B	12.0ct	0.15	2.06	1.38	1.19	1.75	.187	9.20	7.79
546-166K12	166K12	B	12.0ct	1.2	3.25	1.63	2.00	2.81	.187	20.62	17.44
546-166F12	166F12	B	12.6ct	0.3	2.38	1.38	1.38	2.00	.187	14.72	12.46
546-166G12	166G12	B	12.6ct	0.5	2.81	1.50	1.69	2.38	.187	21.60	18.27
546-166J12	166J12	B	12.6ct	1	2.81	1.63	1.69	2.38	.187	21.81	18.46
546-166L12	166L12	B	12.6ct	2.5	3.25	2.00	2.00	2.81	.187	21.83	18.47
546-166N12	166N12	B	12.6ct	4	3.69	2.13	2.31	3.13	.187	26.18	22.16
546-166Q12	166Q12	B	12.6ct	6	4.03	2.25	2.63	3.56	.187	34.89	29.53
546-166R12	166R12	B	12.6ct	8	4.50	2.50	2.88	4.00	.203	51.05	43.21
546-166L22	166L22	B	22.0ct	2	3.69	2.13	2.31	3.13	.187	34.93	29.55
546-166C24	166C24	B	24.0ct	0.085	2.06	1.38	1.19	1.75	.187	10.80	9.14

For quantities of 10 and up, call for quote.

MOUSER STOCK NO.	Hammond Part No.	Fig.	Secondary (RMS)		Dimension: in.					Price Each	
			VAC	Amps	A	B	C	D	E	1	5
546-166L24	166L24	B	24.0ct	2	3.69	2.13	2.31	3.13	.187	24.00	20.30
546-166N24	166N24	B	24.0ct	4	4.50	2.50	2.88	4.00	.203	34.92	29.54
546-166D25	166D25	B	25.0ct	0.1	2.06	1.38	1.19	1.75	.187	21.52	18.21
546-166E25	166E25	B	25.0ct	0.15	2.38	1.38	1.38	2.00	.187	19.79	16.74
546-166F25	166F25	B	25.0ct	0.3	2.81	1.50	1.69	2.38	.187	41.25	34.89
546-166G25	166G25	B	25.0ct	0.5	2.81	1.63	1.69	2.38	.187	22.91	19.40
546-166J25	166J25	B	25.0ct	1	3.25	1.75	2.00	2.81	.187	17.45	14.76
546-166K25	166K25	B	25.0ct	1.5	3.69	1.88	2.31	3.13	.187	27.50	23.26
546-166L25	166L25	B	25.0ct	2	3.69	2.13	2.31	3.13	.187	24.00	20.30
546-166M25	166M25	B	25.0ct	3	4.03	2.25	2.63	3.56	.187	32.71	27.68
546-166F28	166F28	B	28.0ct	0.25	2.81	1.50	1.69	2.38	.187	21.60	18.27