

TAMURA Current Sensors

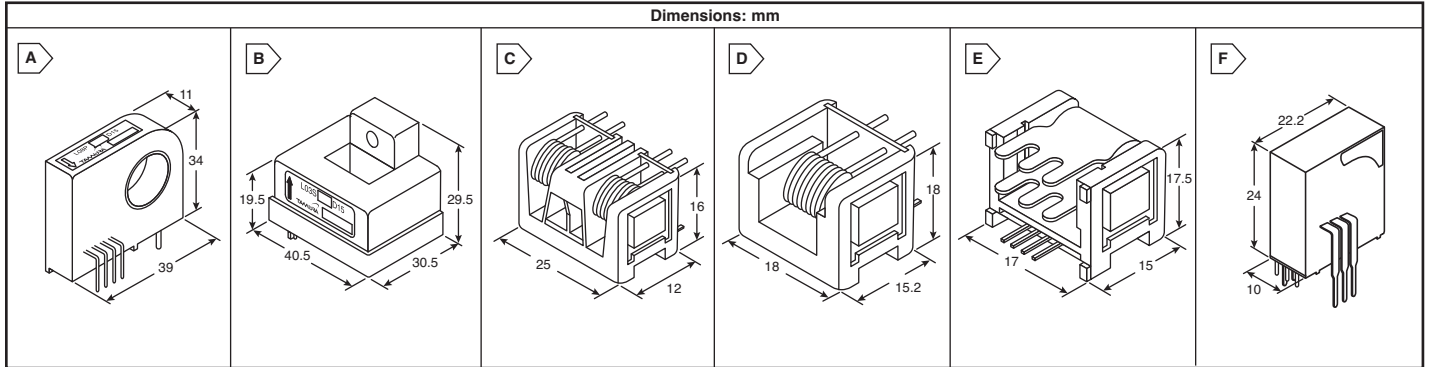

Dimensions: mm



TAMURA OPEN LOOP HALL EFFECT CURRENT SENSORS

In the Tamura Open Loop Hall Effect Current Sensor the magnetic flux is concentrated in the magnetic core that contains the hall effect device. The primary current, which is proportional to the magnetic flux, is measured without electrical contact with the primary circuit providing galvanic isolation.



- Features:**
- Measure: DC, AC, and Pulsed waveforms
 - Galvanic Isolation
 - Zero Insertion Loss
 - Fast Response
 - Cost Effective
- Specifications:**
- Specifications are measured at +25°C, Load Resistor 10kΩ
 - Response Time: 5μ sec. typ. (10μSec. Typ. for L08P Series)
 - Operating Bandwidth (-3dB): L03S, L08P, L18P: DC- 50kHz; L012, L07P: DC-35kHz (At higher frequencies derating is required to prevent core from overheating)
 - Insulation Resistance @ 500VDC: more than 500MΩ
 - Operating Temperature: -10°C to +80°C
 - Output Linearity: ±1%

For quantities of 50 and up, call for quote.

MOUSER STOCK NO.	Tamura Part No.	Fig.	Nominal Primary DC Current	Output Voltage @ Nominal Current	Maximum Current	Power Supply	Offset Temperature Coefficient	Price Each		
								1	10	20
L012 Series										
838-L01Z600S05	L01Z600S05	A	±600AT	±4V	±750AT	±5V ±2%	<±1.0 mV/°C	16.33	14.15	11.40
L03S Series										
838-L03S050D15	L03S050D15	B	±50AT	±4V	±150AT	±15V ±5%	<±2 mV/°C	16.08	12.58	11.53
838-L03S100D15	L03S100D15	B	±100AT	±4V	±300AT	±15V ±5%	<±1 mV/°C	16.08	12.58	11.53
838-L03S200D15	L03S200D15	B	±200AT	±4V	±600AT	±15V ±5%	<±1 mV/°C	16.08	12.58	11.53
838-L03S300D15	L03S300D15	B	±300AT	±4V	±700AT	±15V ±5%	<±1 mV/°C	16.08	12.58	11.53
838-L03S400D15	L03S400D15	B	±400AT	±4V	±700AT	±15V ±5%	<±1 mV/°C	16.08	12.58	11.53
838-L03S500D15	L03S500D15	B	±500AT	±4V	±700AT	±15V ±5%	<±1 mV/°C	16.08	12.58	11.53
838-L03S600D15	L03S600D15	B	±600AT	±4V	±700AT	±15V ±5%	<±1 mV/°C	16.08	12.58	11.53
L07P Series										
838-L07P003D15	L07P003D15	C	±3A	±4V	±9A	±15V ±5%	<±2 mV/°C	16.47	13.61	12.18
838-L07P010D15	L07P010D15	C	±10A	±4V	±30A	±15V ±5%	<±2 mV/°C	16.47	13.61	12.18
L08P Series										
838-L08P050D15	L08P050D15	A	±50AT	±4V	±150AT	±15V ±5%	<±2 mV/°C	14.91	11.66	10.69
838-L08P100D15	L08P100D15	A	±100AT	±4V	±300AT	±15V ±5%	<±1 mV/°C	16.09	12.59	11.54
838-L08P150D15	L08P150D15	A	±150AT	±4V	±350AT	±15V ±5%	<±1 mV/°C	16.09	12.59	11.54
838-L08P200D15	L08P200D15	A	±200AT	±4V	±350AT	±15V ±5%	<±1 mV/°C	16.09	12.59	11.54
L18P Series										
838-L18P003D15	L18P003D15	D	±3A	±4V	±9A	±15V ±5%	<±1.5 mV/°C	11.60	9.57	8.56
838-L18P015D15	L18P015D15	D	±15A	±4V	±45A	±15V ±5%	<±1.5 mV/°C	11.60	9.57	8.56
838-L18P020D15	L18P020D15	D	±20A	±4V	±60A	±15V ±5%	<±1.5 mV/°C	11.60	9.57	8.56
838-L18P025D15	L18P025D15	D	±25A	±4V	±60A	±15V ±5%	<±1.5 mV/°C	11.60	9.57	8.56
838-L18P030D15	L18P030D15	D	±30A	±4V	±90A	±15V ±5%	<±1.5 mV/°C	11.60	9.57	8.56
838-L18P050D15	L18P050D15	E	±50A	±4V	±150A	±15V ±5%	<±1.5 mV/°C	11.96	9.88	8.84

Tamura Current Sensors

TAMURA CLOSED LOOP HALL EFFECT CURRENT SENSORS

The Tamura Closed Loop Hall Effect Current Sensor feeds back an opposing current into a secondary coil wound on the magnetic core to zero the flux produced in the magnetic core by the primary current. The output current of a closed loop current sensor is an exact representation of the primary current scaled by the number of turns in the second coil.



- Features:**
- Measures: DC, AC, and Pulsed waveforms
 - Galvanic Isolation
 - Zero Insertion Loss
 - Fast Response
 - Cost Effective
- Specifications:**
- Specifications are measured at +25°C, Load Resistor 10kΩ
 - Operating Bandwidth: DC-200kHz 1dB (At higher frequencies derating is required to prevent core from overheating)
 - Insulation Resistance @ 500VDC: more than 500MΩ
 - Operating Temperature: -10°C to +85°C
 - Output Linearity: ±0.25%
 - Response Time: 1μ sec.

S22P Series

For quantities of 50 and up, call for quote.

MOUSER STOCK NO.	Tamura Part No.	Fig.	Nominal Primary R.M.S. Current	Maximum Current	Output Voltage @ Nominal Current	Power Supply ±5%	Output Temperature Characteristic	Price Each		
								1	10	20
838-S22P006S05	S22P006S05	F	±6A	±18A	2.5V±0.625V	5V	±0.05mV/°C	16.35	12.80	11.73
838-S22P015S05	S22P015S05	F	±15A	±45A	2.5V±0.625V	5V	±0.05mV/°C	16.35	12.80	11.73
838-S22P025S05	S22P025S05	F	±25A	±75A	2.5V±0.625V	5V	±0.05mV/°C	16.35	12.80	11.73