

POMONA Broadcast Connectors



VIDEO BROADCAST

For quantities of 100 and up, call for quote.

| MOUSER STOCK NO. | | Fig. | Description | Price Each | | |
|---|---------------|------|---|------------|-------|-------|
| Mfr. | Mfr. Part No. | | | 1 | 25 | 50 |
| 75 Ohm Digital BNC Connectors | | | | | | |
| 565—6705 | | A | BNC (F/F) Isolated Panel Connector for Digital Video | 14.24 | 13.56 | 12.88 |
| 75 Ohm BNC Connectors and Adapters | | | | | | |
| 565—6752A | | B | BNC (m) Crimp for RG59, 59A, 59B, 62, 210 cable | 3.53 | 3.36 | 3.19 |
| 565—6746A | | C | BNC (m) Comp Style, field inst, for RG59, 59A, 59B, 62, 210 cable | 2.34 | 2.23 | 2.12 |
| 75 Ohm BNC Within Series Adapters | | | | | | |
| 565—6738 | | D | BNC (f/f/f) Adapter | 3.63 | 3.46 | 3.29 |
| 565—6739 | | E | BNC (f/m/f) Adapter | 3.56 | 3.38 | 3.21 |
| 565—6754 | | F | BNC (f/m/f) Adapter, In-line | 3.74 | 3.56 | 3.38 |
| 565—6740 | | G | BNC (m/m) Adapter | 2.03 | 1.93 | 1.83 |
| 565—6737 | | H | BNC (f/f) Adapter | 2.56 | 2.44 | 2.32 |
| 565—6744 | | I | BNC (f/f) Panel Mount, Hermetically Sealed Adapter | 3.16 | 3.01 | 2.86 |
| 75 Ohm BNC Panel Receptacles | | | | | | |
| 565—6736 | | J | BNC (f) Panel Receptacle, 0.50 in. (13.46mm) hole spacing | 2.67 | 2.54 | 2.41 |
| 565—6735 | | K | BNC (m) Panel Receptacle, 0.50 in. (13.46mm) hole spacing | 3.16 | 3.01 | 2.86 |
| 75 Ohm BNC Female PCB Mount | | | | | | |
| 565—6748 | | L | BNC (f) PCB Mount, Right Angle | 3.16 | 3.01 | 2.86 |
| 565—6747 | | M | BNC (f) PCB Mount, Vertical | 2.75 | 2.62 | 2.49 |
| 565—6718 | | N | BNC (f) PCB Mount, Dual Right Angle, White Valox | 16.01 | 15.25 | 14.49 |
| 75 Ohm BNC Bulkhead Receptacles | | | | | | |
| 565—6745 | | O | BNC (f) Bulkhead Receptacle, 75 Ohm | 2.34 | 2.23 | 2.12 |
| 565—6741 | | O | BNC (f) Bulkhead Receptacle, Isolated Ground, 75 Ohm | 2.56 | 2.44 | 2.32 |
| 75 Ohm BNC Terminators, Dust Cap, Shorting Cap | | | | | | |
| 565—4391-75 | | P | BNC 75 Ohm Attenuator | 39.29 | 37.42 | 35.55 |
| 565—384075 | | Q | BNC Male Terminator Plug, 75 Ohm | 12.84 | 12.23 | 11.62 |
| 565—4119-75 | | R | BNC Feed-Thru Termination, 75 Ohm | 57.50 | 54.76 | 52.02 |
| 565—5085 | | S | BNC Shorting Cap | 5.13 | 4.89 | 4.65 |
| 565—3839 | | S | BNC Dust Cap | 2.67 | 2.54 | 2.41 |

75 OHM BETWEEN SERIES ADAPTER

For quantities of 100 and up, call for quote.

| MOUSER STOCK NO. | | Fig. | Description | Price Each | | |
|------------------|---------------|------|--|------------|-------|-------|
| Mfr. | Mfr. Part No. | | | 1 | 25 | 50 |
| 565—6779 | | T | BNC (m) 75 Ohm / F (f) | 3.41 | 3.25 | 3.09 |
| 565—6780 | | U | BNC (f) 75 Ohm / F (f) | 3.41 | 3.25 | 3.09 |
| 565—6781 | | V | BNC (f) 75 Ohm / F (m) | 3.41 | 3.25 | 3.09 |
| 565—6782 | | W | BNC (m) 75 Ohm / F (m) | 3.41 | 3.25 | 3.09 |
| 565—5319 | | X | BNC Female to Phono Plug | 6.72 | 6.38 | 6.06 |
| 565—4054 | | Y | BNC Male to Phono Jack | 17.36 | 16.47 | 15.69 |
| 565—1297 | | Z | BNC Female to 1/4in (6.35mm) Phono Plug | 11.50 | 10.95 | 10.40 |
| 565—3837 | | AA | BNC Female to Two Conductor, 0.14in (3.5mm) Dia. Tini Plug | 14.54 | 13.85 | 13.25 |
| 565—4043 | | BB | BNC Male to 1/4in (6.35mm) Two Conductor Phone Jack | 39.08 | 37.22 | 35.36 |
| 565—6519 | | CC | BNC Female to Mini-WECO Plug Adapter | 32.08 | 30.55 | 29.02 |
| 565—5008 | | CC | BNC Female to Standard WECO Plug Adapter | 44.11 | 42.01 | 39.91 |
| 565—4719 | | DD | BNC Female to Bantam Plug Adapter | 21.84 | 20.80 | 19.76 |

75 OHM CABLE ASSEMBLIES

For quantities of 100 and up, call for quote.

| MOUSER STOCK NO. | | Fig. | Description | Length | Price Each | | |
|------------------|---------------|------|---|--------------|------------|-------|-------|
| Mfr. | Mfr. Part No. | | | | 1 | 25 | 50 |
| 565—6510-V-36-0 | | EE | BNC Male True 75 Ohm High Flex Cable | 36in (0.9m) | 18.52 | 17.64 | 16.76 |
| 565—6510-V-48-0 | | EE | BNC Male True 75 Ohm High Flex Cable | 48in (1.2m) | 22.27 | 21.21 | 20.15 |
| 565—6510-V-60-0 | | EE | BNC Male True 75 Ohm High Flex Cable | 60in (1.5m) | 22.27 | 21.21 | 20.15 |
| 565—6510-V-72-0 | | EE | BNC Male True 75 Ohm High Flex Cable | 72in (1.8m) | 26.02 | 24.78 | 23.54 |
| 565—2249-E-36 | | FF | BNC Male Cable with Molded Strain Reliefs | 3ft (0.9m) | 14.96 | 14.19 | 13.52 |
| 565—2249-E-72 | | FF | BNC Male Cable with Molded Strain Reliefs | 6ft (1.8m) | 17.57 | 16.66 | 15.88 |
| 565—2249-E-120 | | FF | BNC Male Cable with Molded Strain Reliefs | 10ft (3.0m) | 22.69 | 21.61 | 20.53 |
| 565—2249-E-144 | | FF | BNC Male Cable with Molded Strain Reliefs | 12ft (3.7m) | 24.58 | 23.41 | 22.24 |
| 565—2249-E-180 | | FF | BNC Male Cable with Molded Strain Reliefs | 15ft (4.6m) | 27.20 | 25.90 | 24.61 |
| 565—2249-E-240 | | FF | BNC Male Cable with Molded Strain Reliefs | 20ft (6.1m) | 32.12 | 30.59 | 29.06 |
| 565—2249-E-300 | | FF | BNC Male Cable with Molded Strain Reliefs | 25ft (7.6m) | 37.15 | 35.38 | 33.61 |
| 565—2249-E-600 | | FF | BNC Male Cable with Molded Strain Reliefs | 50ft (15.2m) | 60.61 | 57.72 | 54.83 |

F CONNECTORS

For quantities of 100 and up, call for quote.

| MOUSER STOCK NO. | | Fig. | Description | Price Each | | |
|---|---------------|------|---|------------|------|------|
| Mfr. | Mfr. Part No. | | | 1 | 25 | 50 |
| 75 Ohm Type "F" Within Series Adapters | | | | | | |
| 565—6800 | | GG | 75Ω Type F (m/f) Right Angle Adapter | 3.37 | 3.21 | 3.05 |
| 565—6801 | | HH | 75Ω Type F (m/f) in-line Adapter | 1.27 | 1.21 | 1.15 |
| 75 Ohm Type "F" Bulkhead Receptacle | | | | | | |
| 565—6802 | | II | 75Ω Type F (f/f) in-line, with nut and washer | 1.39 | 1.32 | 1.25 |
| 75 Ohm Type "F" PCB Mount | | | | | | |
| 565—6803 | | JJ | 75Ω Type F (f), vertical mount with PTFE insulator. | 2.05 | 1.95 | 1.85 |

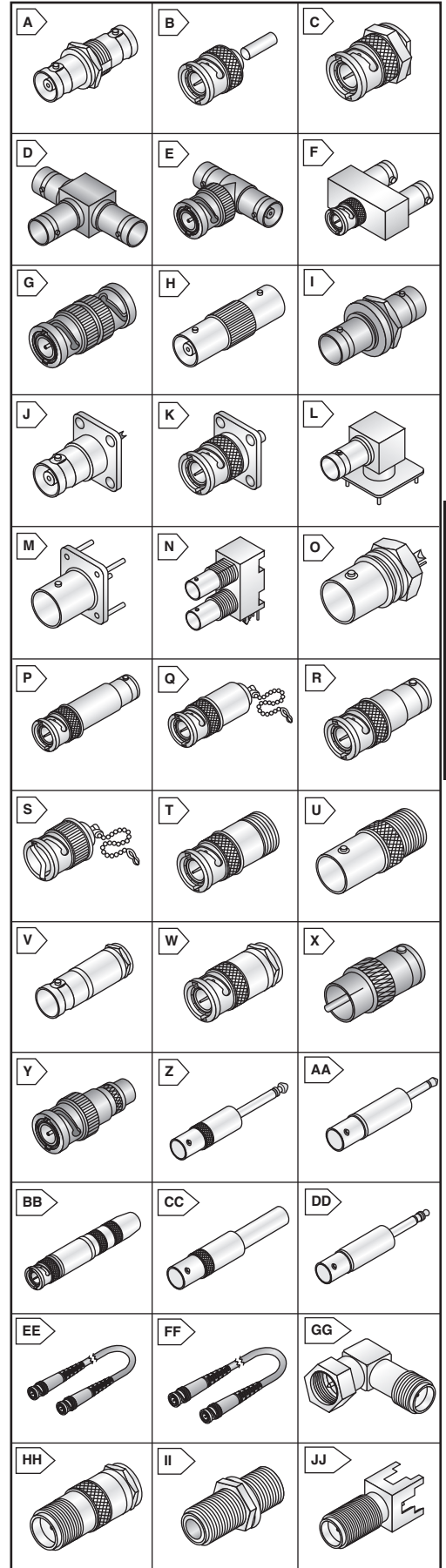

Audio/Video Connectors Pomona