

# PANDUIT Cable Ties and Tools

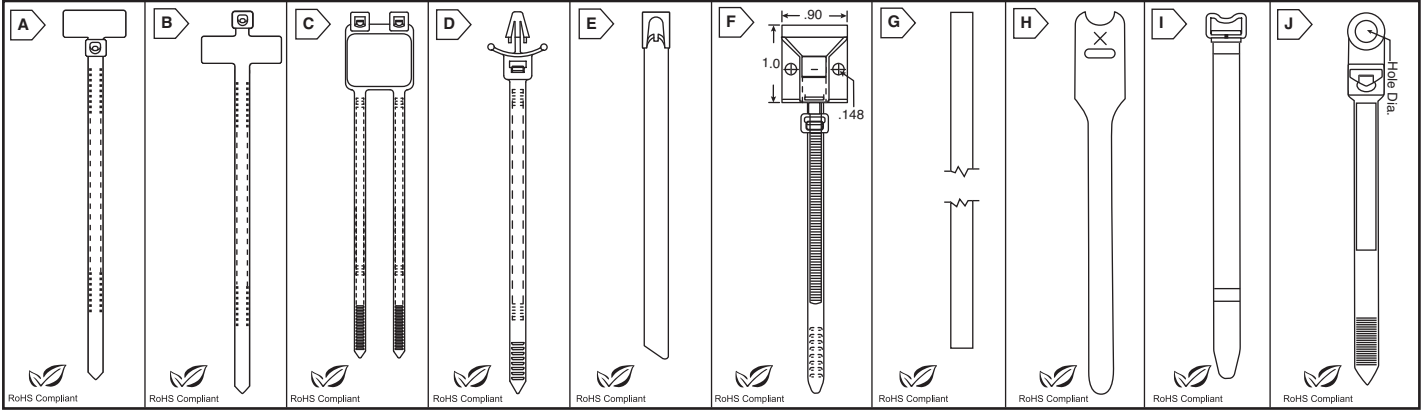

RoHS Compliant This product is RoHS compliant.



## NYLON 6.6 MARKER TIES WITH TAGS

- Natural Nylon
- UL94V-2 rating
- Used to fasten and identify bundles at the same time

MOUSER STOCK NO.	Fig.	Tensile Strength (lbs.)	Length (in.)	Max. Bundle Dia. (in.)	Width (in.)	Price Each			
						1	100	500	1000
<b>Nylon 6.6 (Natural)</b>									
644-PLF1M-M	A	18	4.3	0.87	0.098	.33	.16	.14	.13
644-PLM1M-M	B	18	3.9	0.75	0.098	.38	.16	.14	.13
644-PLM2M-M	B	18	8	2	0.098	.50	.29	.24	.21
644-PLM2S-D	B	18	7.4	1.75	0.098	.70	.27	.26	.25
644-PL2M2S-L	C	50	7.4	1.75	0.185	1.74	1.53	1.46	1.32
<b>Weather (UV) Resistant Nylon 6.6 (Black)</b>									
644-PLF1M-M0	A	18	4.3	0.87	0.098	.46	.27	.21	.18
644-PLM2M-M0	B	18	8	2	0.098	.61	.30	.297	.285
<b>Nylon 6.6 Winged Push Mount Ties</b>									
644-PLWP1M-D	D	18	4.3	.87	.098	.25	.21	.20	.18
644-PLWP1L-SI-C	D	40	6.0	1.25	.135	.37	.29	.24	.22
644-PLWP1S-C	D	50	5.2	1.00	.190	.40	.34	.25	.23
644-PLWP2S-C	D	50	7.8	1.75	.190	.45	.35	.29	.26
644-PLWP3H-TL	D	120	12.0	3.00	.300	.87	.77	.73	.65

## TAK-TY® HOOK AND LOOP CABLE TIES

- Black
- Material: Nylon loop, polyethylene hook
- Adjustable, releasable and reusable

MOUSER STOCK NO.	Fig.	Tensile Strength (lbs.)	Length (in.)	Max. Bundle Dia. (in.)	Width (in.)	Price Each			
						1	10	100	500
644-HLS1.5S-X0	G	50	6.0	1.5	.75	1.09	.92	.872	.832
644-HLT2L-X0	H	40	8.0	1.9	.50	1.28	1.17	1.03	.94
644-HLTP2L-X0	H	40	8.0	1.9	.50	1.67	1.52	1.44	1.37
644-HLC3S-X0	I	50	12.0	3.0	.75	1.83	1.70	1.56	1.44
644-HLTP3L-X0	H	50	12.0	3.0	.75	2.16	1.69	1.36	1.29
644-HLS3S-X0	G	50	12.0	3.2	.75	1.97	1.83	1.70	1.58
644-HLSP3S-X0	G	50	12.0	3.2	.75	2.91	2.27	1.82	1.73
644-HLT3L-X0	H	40	12.0	3.2	.50	1.77	1.52	1.39	1.20
644-HLS5S-X0	I	50	18.0	5.0	.75	2.33	2.13	1.76	1.52
644-HLSS5-X0	I	50	18.0	5.0	.75	2.71	2.40	2.26	2.04
644-HLSP5S-X0	G	50	18.0	5.0	.75	3.64	2.84	2.27	2.16
644-HLS-15R0	G	50	180.0	Various	.75	23.38	21.12	18.73	17.60

## PAN-STEEL™ STAINLESS STEEL METAL LOCKING

- General Purpose

MOUSER STOCK NO.	Fig.	Tensile Strength (lbs.)	Length (in.)	Max. Bundle Dia. (in.)	Width (in.)	Price Each			
						1	100	500	1000
644-MLT1S-CP	E	100	5.00	1.00	0.18	.99	.89	.79	.69
644-MLT2S-CP	E	100	7.90	2.00	0.18	1.06	.95	.85	.75
644-MLT4L-LP	E	100	14.30	4.00	0.18	1.50	1.35	1.20	1.12
644-MLT4S-CP	E	100	14.20	4.00	0.18	1.25	1.12	1.00	.87
644-MLT6H-LP	E	100	20.50	6.00	0.18	2.23	2.01	1.79	1.67
644-MLT6S-CP	E	100	20.40	6.00	0.18	1.86	1.69	1.50	1.41

## STAINLESS STEEL MARKER PLATE

- Color: Natural
- Long life
- For quantities of 5000 and up, call for quote.

MOUSER STOCK NO.	Size (W x L)	Description	Price Each			
			1	100	500	1000
644-MMP350-C	.75" x 3.50"	304 stainless steel	.85	.77	.67	.60

## ADHESIVE MOUNT/CABLE TIE COMBO

- Adhesive mount & cable tie molded as one piece helps reduce inventory costs.
- Color: White
- Locking cable tie

MOUSER STOCK NO.	Fig.	Tensile Strength (lbs.)	Length (in.)	Max. Bundle Dia. (in.)	Width (in.)	Price Each			
						1	100	500	1000
644-PLA2S-A-Q	F	50	7.30	1.85	.19	1.53	1.36	1.11	1.04

## CABLE TIE INSTALLATION TOOLS

- The preferred tool design in the industry.
- Lightweight and balanced.
- Requires no special maintenance.
- Rugged all-steel construction
- Easy to operate.

### GS4H

- Installs standard, light heavy and heavy cross section cable ties
- Installs superflex cable ties
- Q.P.L. per Mil. std. MS90387-2 and Mil. spec. Mil-T-81306A

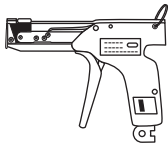

644-GS4H	374.17
----------	--------

### STS2

- Instalar controlled tension and cut-off
- Perfect size for pocket or tool box
- Especially suited to maintenance and construction applications
- Installs miniature, intermediate and standard ties

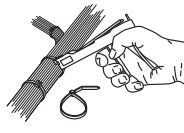

644-STS2	28.62
----------	-------

### ST2MT

- Used with all Pan-Steel™ type MLT
- Single handle trigger for fast installation
- Cut off capability with the twist of the wrist

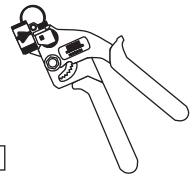

644-ST2MT	319.49
-----------	--------

### HTMT

- Specially adapted screwdriver type tool is used to tension standard and heavy cross section ties safely
- Used with all Pan-Steel™ type MLT ties, type MLTC coated ties and type MLPT plenum ties
- Manual tension, no cut-off

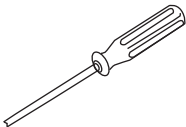

644-HTMT	22.26
----------	-------

### GTS

- Installs miniature, intermediate and standard cross section cable ties
- Manual tool/lightweight 8.8oz.
- Meets Mil. std. MS90387-1

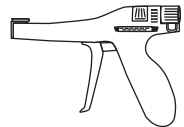

644-GTS	175.00
---------	--------

### GTH

- Installs Standard, Heavy-Standard, Light-Heavy and Heavy cross section cable ties
- Manual tool/lightweight 11.2oz.

644-GTH	320.24
---------	--------

### GS2B

- Tool controlled tension and cut-off
- Automatic tension and cut-off by squeezing trigger
- Reduces fatigue and increases productivity
- Especially suited to medium production applications
- Q.P.L. per Mil. Std. MS90387-1
- Installs miniature, intermediate and standard ties

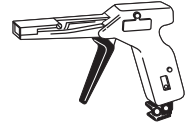

644-GS2B	210.97
----------	--------